



TENDER NO: BID/NC062/18/2025-2026

NAMA KHOI MUNICIPALITY

NOTICE NUMBER: 101/2025

SUPPLY AND DELIVERY OF HOUSE CONNECTION MATERIAL

IMPORTANT NOTES TO BIDDERS:

- Tenders must be properly received and deposit in the tender box on or before the closing date and before the closing time at tender submission office, situated at the entrance to the Head office of Nama Khoi Municipality, 4 Namaqua Street, Springbok, 8240.
- No late bids will be accepted under any circumstances.
- Tender offers must be submitted in a sealed envelope clearly reflecting the tender number and description as indicated above,
- Only original tenders will be accepted.
- Do not dismember this bid document rather attached schedules and supporting documentation.
- In the event that a bidder is not registered for VAT and the bid is expected to exceed R 1 million, the bidder is expected to include a statement of intent to register for VAT.
- Bid documents of other bidders are not available to other bidders which may prejudice them in commercial competition.
- Tender fee: R **666.77** (Taxes included) in cash or electronic transfer per document. This amount is non-refundable.
- Tender document can be downloaded for free from:
www.namakhoi.gov.za (Documents – Supply Chain Information - Bid Invitation Adverts - Bid Invitation Advert 2025/2026)

To be completed by Bidder

Entity name:		Address	
Registration Number:			
Telephone:		Delivery Period	
Fax:		CSD Registration number	
Email:		Representative appointed by resolution:	

Starting Date: 21 November 2025

Closing Date: 05 December 2025

Closing Time: 12:00 Midday

Contact the SCM Unit on advice on completing the bid documentation Acting Senior Accountant SCM Ms. Candice Rabie
– (027) 718 8210

Technical specification enquiries:
Mr. J H Adams (027) 718 8100

SCM Officials in attendance at the opening of the Bids

	Name	Signature
1.		
2.		



PART	TENDER AND CONTRACT CONTENTS	PAGES
PART A – TENDER INVITATION		1
1	Tender notice and invitation to tender	2
2	Standard conditions of tender/ Instructions to bidders	3-12
3	Tender Offer	13
4	Tender Acceptance	14
PART B – TENDER RETURNABLE DOCUMENTS AND SCHEDULES		15
1	Invitation to bid (MBD 1)	16-18
2	Original tax clearance certificate requirements (MBD 2)	18
3	Declaration of interest – Employees in the service of the State(MBD 4)	19-23
4	Declaration for procurement above R 10 million (all taxes included) (MBD 5)	24
5	Preference points claim form in terms of the preferential procurement regulations 2011 (MBD 6.1)	25-29
6	Local Content (MBD 6.2)	30
7	Contract form – Procurement of Services (MBD 7.2)	31-32
8	Declaration of bidder’s past supply chain management practices (MBD 8)	33-34
9	Certificate of independent bid determination (MBD 9)	35
10	Declaration on state of municipal accounts at all municipalities of the bidder (SCM 1)	36
11	Certificate of authority for incorporated or unincorporated Joint Venture (JV), Consortiums and Partnerships Disclosure form	37-38
12	Supply Chain Management and Regulation 12 Preferential Procurement Regulations Declaration	39
13	Resolution by Director/Members/ other	40
14	Conflict of interest declaration – gifts and sponsorships	41
15	List of other documentation attached by bidder	42
PART C : IMPORTANT TENDER INFORMATION		43
PART D: AGREEMENTS AND CONTRACT DATA		44
1	General Conditions of Contract (GCC)	45-54
PART E: PRICING DATA		55
1	Pricing instructions	56
2	Pricing schedule - Bill of Quantities	57-58
PART F: SPECIFICATIONS PRICING DATA / SCOPE OF WORK		59
1	Specifications	60-61
DOCUMENTS TO BE ATTACHED		62 – 67



(PART A) TENDER NOTICE AND INVITATION TO TENDER

1. TENDER NOTICE AND INVITATION TO TENDER
2. STANDARD CONDITIONS OF TENDER
3. TENDER OFFER
4. TENDER ACCEPTANCE

(1). TENDER NOTICE AND INVITATION TO TENDER

NAMA KHOI LOCAL MUNICIPALITY			
TENDER NOTICE AND INVITATION TO TENDER			
	ADVERTISED ON:	MUNICIPAL NOTICE BOARD; MUNICIPAL WEBSITE; NATIONAL TREASURY e-TENDER; CIDB i-Tender	
	NOTICE NO: 101/2025	BID/NC062/18/2025-2026	
Tenders are hereby invited for: SUPPLY AND DELIVERY OF HOUSE CONNECTION MATERIAL			
PUBLISHED DATE:	21 NOVEMBER 2025	CLOSING DATE:	05 DECEMBER 2025 @ 12H00
CLOSING TIME	Formal tenders sealed and clearly marked BID/NC062/18/2025-2026 SUPPLY AND DELIVERY OF HOUSE CONNECTION MATERIAL must be placed in the Municipal tender box, Municipal Offices Reception Area, 04 Namakwa Street, Springbok, 8240 no later than 12h00 on 05 DECEMBER 2025 and will be opened in public immediately thereafter.		
AVAILABILITY OF TENDER DOCUMENTS:			
Tender Documents will be available electronically for preparation purposes. Tender documents to be obtained from responsible municipal officials at the cost of allocated fee mentioned below, for submission purposes.			
Bid documents will be available online for download, only for preparation purposes and hardcopies will be available at the municipality from the date of the advertisement at the cost of the allocated fee, R666.77, for submission purposes. Proof of payment must accompany tender document.		A payment request should be send to: Christeline Klaase: Email: christeline.klaase@namakhoi.gov.za Proof of payment must be provided in order to retrieve a tender document	
Date Available:	21 November 2025 @ 12H00	Non-refundable Fee:	R 666.77 VAT incl.
TENDER SUBMISSION RULES:			
<ol style="list-style-type: none"> Tenders are to be completed in accordance with the conditions and Tender rules contained in the Tender document. The Tender Document & supporting documents must be placed in a sealed envelope and externally endorsed WITH: THE TENDER NUMBER; DESCRIPTION & CLOSING DATE OF THE TENDER. Tender Documents must be placed in the Municipal tender box, Municipal Offices Reception Area, 04 Namakwa Street, Springbok, 8240 no later than 12h00 on 05 December 2025 and will be opened in public immediately after tender closing. Tenders may only be submitted on the Tender documentation issued by the Municipality. Nama Khoi Municipality does not bind itself to accept the lowest or any tender and reserves the right to accept any tender, as it may deem expedient. Tenderers who are not yet registered are required to register on the National Central Suppliers Database (CSD). Application forms are obtainable from the website https://secure.csd.gov.za. Tenderers will be required to have a specified level of experience to be eligible to tender. 			
Tenders shall be evaluated in terms of the SCM Policy		Tenderers may claim preference points in terms of the 80/20 principle per the Specific Goals set out in the tender document	
Preferential Procurement Regulations - Local Content Requirement		As stipulated in the Tender Document	
CIDB Registration Required		N/A	
Experience of Service Provider / Company in relation to the scope of work as per Schedule 4: (Functionality Criteria)		As stipulated in the Tender Document	
Experience of Key Personnel as per Schedule 10: (Functionality Criteria)		N/A	
Bank Rating (Functionality Criteria)		N/A	
Plant & Equipment as per Schedule 5 (Functionality Criteria)		N/A	
LOCAL SMME SUB-CONTRACTING TARGET		N/A	
Site Meeting/Information Session	No compulsory clarification meeting will be held.		Validity Period 120 Days
ANY ENQUIRIES REGARDING TECHNICAL INFORMATION MAY BE DIRECTED TO:		ANY ENQUIRIES REGARDING THE TENDERING PROCEDURE MAY BE DIRECTED TO:	
Section:	Technical Services	Section:	Supply Chain Management
Contact Person:	Mr. J H Adams	Contact Person:	Ms. C Rabie
Tel:	027 718 8100	Tel:	027 718 8210
E-mail:	johannes.adams@namakhoi.gov.za	E-mail:	candice.rabie@namakhoi.gov.za
Authorised by:	ACTING MUNICIPAL MANAGER RPS SEBELA		

(2). STANDARD CONDITIONS OF TENDER/ INSTRUCTIONS TO BIDDERS

NOTICE NO.: 101/2025
BID NUMBER: BID/NC062/18/2025-2026

Starting Date: 21/11/2025

Closing Date: 05/12/2025

Closing Time: 12:00 Midday

ALL TENDER CONDITIONS AND/OR INSTRUCTIONS SET OUT BELOW MUST BE STRICTLY ADHERED TO, FAILING WITH THIS TENDER SUBMISSION MAY BE DECLARED NON-RESPONSIVE.

2.1. General

- 2.1.1. No tender will be considered unless submitted on this Nama Khoi Municipality tender document.
- 2.1.2. Any portion of the tender document not completed will be interpreted as “not applicable”. Notwithstanding the foregoing, failure to complete any compulsory portion of the tender document may result in the tender being declared non-responsive.
- 2.1.3. Tenders must be properly received and deposited in the designated Tender box (as detailed on the front page of this Tender document) in the relevant Tender box at the Tender Submission Office situated on the first floor, 4 Namakwa Street, Springbok, 8240 on or before the closing date and before the closing time. If the Quotation submission is too large to fit in the allocated box, please enquire at the public counter for assistance.
- 2.1.4. Nama Khoi Municipality reserves the right to accept:
 - (a) or reject any variation, deviation, Tender offer, or alternative Tender offer, and may cancel the Tender process and reject all Tender offers at any time before the formation of a contract. Nama Khoi Municipality shall not accept or incur any liability to a Bidder for such cancellation and rejection, but will give written reasons for such action upon receipt of a written request to do so.
 - (b) a Tender offer which does not, in Nama Khoi Municipality’s opinion, materially and/ or substantially deviate from the terms, conditions and specifications of the Tender document.
 - (c) the entire Tender or part of a Tender or any item or part of any item, or to accept more than one Tender (in the event of a number of items being offered), and Nama Khoi Municipality is not obliged to accept the lowest or any Tender.
- 2.1.5. Nama Khoi Municipality shall not consider Tender documents that are received after the closing date and time for such a Tender (late Tender document).
- 2.1.6. Nama Khoi Municipality will not be held responsible for any expenses incurred by Bidders in preparing and submitting a Tender.
- 2.1.7. Nama Khoi Municipality may, after the closing date, request additional information or clarification of a tenderer in writing.
- 2.1.8. A Bidder may request information, after the closing date, in accordance with the Promotion of Administrative Justice Act, Act 3 of 2000, and the Promotion of Access to Information Act, Act 2 of 2000.

2.1.9. A Bidder may request in writing, after the closing date, that the Tender offer be withdrawn. Such withdrawal will be permitted or refused at the sole discretion of Nama Khoi Municipality after consideration of the reasons for the withdrawal, which shall be fully set out by the Bidder in such written request for withdrawal.

2.1.10.

Should the Tender offer be withdrawn in contravention of 2.1.9 above, the Bidder agrees that:

- (a) it shall be liable to Nama Khoi Municipality for any additional expense incurred or losses suffered by Nama Khoi Municipality in having either to accept another Tender or, if a new tender have to be invited, the additional expenses incurred or losses suffered by the invitation of a new tender and the subsequent acceptance of any other Tender;
- (b) Nama Khoi Municipality shall also have the right to recover such additional expenses or losses by setting them off against any monies that may be due or become due to the Bidder under this or any other tender or contract, or against any guarantee or deposit that may have been furnished by the Bidder, or on its behalf, for the due fulfilment of this or any other tender or contract. Pending the ascertainment of the amount of such additional expenses or losses, Nama Khoi Municipality shall be entitled to retain such monies, guarantee or deposit as security for any such expenses or loss.

2.1.11.

The Bidder agrees that this tender and its acceptance shall be subject to the terms and conditions contained in Nama Khoi Municipality Supply Chain Management Policy ("SCM Policy")

2.1.12.

Notwithstanding any requests for confirmation of receipt of notices issued to the Bidders, the Bidder shall be deemed to have received such notice if Nama Khoi Municipality can show proof of transmission thereof via electronic mail, facsimile or registered post.

2.1.13.

Unless otherwise stated in this Tender document, all information submitted by the Bidder contained in other documents for example, cover letters, brochures, catalogues etc. submitted with the Tender offer, will not be considered during evaluation unless such documents have been recorded and referenced in **PART B: List of Other Documents Attached by Bidder.**

2.2. Resolutions and Authorities

A Tender submitted:

- 2.2.1. by a registered company may not be considered unless accompanied by a resolution by the Directors of the company authorizing the Tender to be made and the signatory to sign the Tender on the company's behalf (Attach to **PART B**);
- 2.2.2. by a registered close corporation may not be considered unless accompanied by written authority from all the members of the close corporation authorizing the Tender to be made and the signatory to sign the Tender on the close corporation's behalf (Attach to **PART B**);
- 2.2.3. by a partnership/joint venture/consortium may not be considered unless accompanied by written authority from all parties to the partnership/joint venture/consortium authorizing the Tender to be made and the signatory to sign the Tender on the partnership//joint venture/consortium's behalf (Attach to **PART B**).

2.3. Partnerships/Joint Ventures(JV's)/Consortiums

In the case of partnerships/joint ventures/consortiums, a copy of the partnership/joint venture/ consortium agreement must be submitted with the Tender document. All parties/partners to the partnership/joint venture/consortium agreement must be registered on Nama Khoi Municipality's Vendor Database.

2.4. Validity Period

- 2.4.1. A Tender submitted shall remain valid, irrevocable and open for acceptance by Nama Khoi Municipality for 90 (ninety) days.
- 2.4.2. A Tender submitted shall further be deemed to remain valid after the expiry of the above mentioned 30 day period, until formal acceptance by Nama Khoi Municipality, unless Nama Khoi Municipality is notified in writing by the Bidder of anything to the contrary (including any further conditions the Bidder may introduce).
- 2.4.3. Any further conditions that the Bidder may introduce will be considered at the sole discretion of Nama Khoi Municipality.

2.5. Tax clearance

- 2.5.1. Bidders shall be registered and in good standing with the South African Revenue Service (SARS). In this regard, it is the responsibility of the Bidder to submit to Nama Khoi Municipality documentary evidence in the form of an original valid Tax Clearance Certificate issued by SARS.
- 2.5.2. Each party to a Partnership/Joint Venture/Consortium shall submit a separate Tax Clearance Certificate.
- 2.5.3. Bidders are to note that Nama Khoi Municipality will not award a contract to a Bidder whose tax matters are not in order.
- 2.5.4. Bidders that have a verified SARS e-filing notification that tax matters are in order may also submit within 10 days of being so requested by the municipality, an original and valid tax certificate.

2.6. Specific goals

2.6.1. The number of preference points shall be determined as stipulated in **PART B**.

2.7. Independent Bid Determination

2.7.1. Bidders must complete, sign and submit, together with their Tender or upon being requested to do so in writing, a certificate of independent bid determination (**PART B**) Should the bidder fail to comply, the Tender offer may be declared non-responsive.

2.7.2. Tenders may also be declared non-responsive if it is determined on reasonable grounds or evidence that the Formal written quotations are submitted by Bidders:

(a) who (notwithstanding having submitted duly completed certificates of independent Tender determination) are nevertheless deemed to have knowledge of the contents of any other Bidder's offer and/or has submitted a certificate which is not true and correct in every respect;

(b) in a horizontal relationship which has the effect of substantially preventing or lessening competition in a market, subject to the exceptions as set out in section 4(1)(a) of the Competitions Act, 89 of 1998;

(c) who are presumed to be firms engaged in a restrictive horizontal practice as contemplated in section 4(1)(b) read with section 2 of the Competitions Act, 89 of 1998;

(d) in a vertical relationship which has the effect of substantially preventing or lessening competition in a market, subject to the exceptions as set out in section 5(1) of the Competitions Act, 89 of 1998.

2.8. Fronting

2.8.1. Nama Khoi Municipality supports the spirit of broad based black economic empowerment and recognizes that real empowerment can only be achieved through individuals and businesses conducting themselves in accordance with the Constitution and in an honest, fair, equitable, transparent and legally compliant manner.

2.8.2. Against this background, Nama Khoi Municipality condemn any form of fronting.

2.8.3. Nama Khoi Municipality, in ensuring that bidders conduct themselves in an honest manner will, as part of the bid evaluation processes, conduct or initiate the necessary enquiries/investigations to determine the accuracy of the representation made in bid documents. Should any of the fronting indicators as contained in the Guidelines on Complex Structures and Transactions and Fronting, issued by the Department of Trade and Industry, be established during such enquiry / investigation, the onus will be on the bidder / contractor to prove that fronting does not exist. Failure to do so within a period of 14 days from date of notification may invalidate the bid / contract and may also result in the restriction of the bidder /contractor to conduct business with the public sector for a period not exceeding ten years, in addition to any other remedies the Nama Khoi Municipality may have against the bidder / contractor concerned.

2.9. Prohibited practices

- 2.9.1. In terms of section 4 (1) of the Competition Act No. 89 of 1998, as amended, an agreement between, or concerted practice by, firms, or a decision by an association of firms, is prohibited if it is between parties in a horizontal relationship and if a bidder (s) is / are or a contractor(s) was / were involved in:
- directly or indirectly fixing a purchase or selling price or any other trading condition;
 - dividing markets by allocating customers, suppliers, territories or specific types of goods or services; or
 - collusive bidding.
- 2.9.2. If a bidder(s) or contractor(s), in the judgment of the purchaser, has / have engaged in any of the restrictive practices referred to above, the purchaser may refer the matter to Special Requirement and Conditions of Contract the Competition Commission for investigation and possible imposition of administrative penalties as contemplated in the Competition Act No. 89 of 1998.
- 2.9.3. If a bidder(s) or contractor(s) has / have been found guilty by the Competition Commission of any of the restrictive practices referred to above, the purchaser may, in addition and without prejudice to any other remedy provided for, invalidate the bid(s) for such item(s) offered, and / or terminate the contract in whole or part, and / or restrict the bidder(s) or contractor(s) from conducting business with the public sector for a period not exceeding ten (10) years and / or claim damages from the bidder(s) or contractor(s) concerned.

2.10. Undertaking – not being actual manufacturer of products

2.10.1.

In the event of the bidder not being the actual manufacturer and will be sourcing the products from another company, a letter from that entity/ supplier(s) confirming firm supplier arrangement(s) including lead times in this regard, must accompany your bid at the closing time and date.

2.10.2.

The said company/ manufacturer/ supplier issuing the letter must confirm that it has familiarized itself with the item description/ specifications and bid conditions and if the bid consist of more than one item, it should be clearly indicated i.r.o which item(s) the supportive letter has been issued.

2.10.3.

It must be indicated in the letter that all the terms and conditions are mutually agreed upon.

2.11. Counter conditions

- 2.11.1. Bidders attention is drawn to the fact that amendments to any Special Conditions by bidders will result in the invalidation of such bids.

2.12. Inducements, rewards, gifts and other abuses of the Supply Chain Management System

2.12.1.

No person who is a provider or prospective provider of goods or services, or a recipient or prospective recipient of goods disposed or to be disposed of may directly or indirectly through a representative or intermediary promise, offer or grant:

- a) any inducement or reward to Nama Khoi Municipality for or in connection with the award of a contract; or
- b) any reward, gift, favor or hospitality to any official or any other role player involved in the implementation of the supply chain management policy.

2.12.2.

No person may influence or interfere with the work of any Nama Khoi Municipality officials involved in the Tender process in order to *inter alia*:

- a) influence the process and/or outcome of a bid;
- b) incite breach of confidentiality and/or the offering of bribes;
- c) cause over and under invoicing;
- d) influence the choice of procurement method or technical standards;
- e) influence any Nama Khoi Municipality Official in any way which may secure an unfair advantage during or at any stage of the procurement process.

2.12.3.

Abuse of the Supply Chain Management System is not permitted and may result in the Tender being rejected, cancellation of the contract, "blacklisting" and/or any such remedies as determined by the municipality's SCM Policy and the Blacklisting Policy.

2.13. Declarations and authorization

Bidders are required to complete all statutory declarations and authorizations in the schedules attached hereto failing which the Tender may be disqualified in terms of Evaluation Criteria.

2.14. Expenses due to the preparation and submission of bid documents

Nama Khoi Municipality shall not be liable for any expenses or losses incurred by the Bidder/bidder due to visiting the site or municipal area and the preparation and/or submission of the Tender/bid documents.

2.15. Acceptance or rejection of bids

Nama Khoi Municipality is not compelled to accept the lowest or any Tender/bid and reserves the right to accept any Tender/bid.

2.16. Clarification information session

No site clarification meeting will be held for this tender.

2.17. Awards to tenderers who are not the highest ranked

2.17.1. Normally the tenderer that scores the highest number of adjudication points must be recommended for acceptance, unless objective criteria stated in bid document justify the acceptance of another tender

2.17.2. The bidder will still have to satisfy objective criteria which may include the following;

- (a) The bidder has demonstrated that it has the necessary resources and skills required to fulfill its obligations in terms of the tender document;
- (b) It does not pose any commercial or legal risk to Nama Khoi Municipality;
- (c) It is not currently subject to action in accordance with the SCM Policy.

2.18. Alterations to bid documents

Do not make any alterations or additions to the bid document, except as to comply with instructions issued by the municipality, or to make the necessary corrections made by the bidder. All signatories to the tender offer shall initial all such alterations. Erasures and the use of masking fluid are prohibited

2.19. Alternative tender offers

- 2.19.1.** Alternative bids can be submitted provided that an acceptable bid, which complies with the bid conditions and specifications and submitted strictly in accordance with the bid documents, is also submitted.
- 2.19.2.** An alternative bid shall be submitted on a separate complete set of bid documents or in accordance with such conditions as may be set out in the bid document and shall be clearly marked "Alternative Bid" to distinguish it from the acceptable bid referred to above.
- 2.19.3.** All acceptable bids (excluding alternative bids) shall first be evaluated in accordance with the bid conditions and ranked. Only the alternative of the highest ranked acceptable bid (that is, submitted by the same bidder) may be considered, and if appropriate, recommended for award.
- 2.19.4.** Alternative bids of any but the highest ranked acceptable tender, shall not be considered.
- 2.19.5.** If the alternative bid of the highest ranked acceptable tender is considered to have merit, then the alternative bid shall be ranked along with all of the acceptable tenders received.
- 2.19.6.** An alternative of the highest ranked acceptable tender that is priced higher than the first ranked tender may be recommended for award, provided that the ranking of the alternative bid is higher than the ranking of the next ranked acceptable tender.
- 2.19.7.** Nama Khoi Municipality however will not be bound to consider alternative bids.

2.20. Closing date

- 2.20.1.** Please ensure that your bid is submitted within the closing date and time of the bid. Accept that proof of posting will not be accepted as proof of delivery.
- 2.20.2.** Accept that if the employer extends the closing date and time stated in the bid documents for any reason, the requirements of these conditions of tender apply equally to the extended deadline.

2.21. Issue Addenda and Extension of Closing Date/Time

- 2.21.1.** If necessary, the Municipality may issue addenda that may amend or amplify the tender documents to each tenderer during the period from the date the tenderer documents are available until seven days before the tender closing time stated in the Tender documents. If, as a result, a tenderer applies for an extension to the closing time stated in the Tender Documents, the Municipality may grant such extension and shall then notify all tenderers who drew documents.
- 2.21.2.** The register of entities that has drawn tender documents shall be used as the distribution list for any addenda. Each person/entity who collects tender documents must supply an e-mail address written legibly with each character clearly identifiable. The Municipality may inform the tenderers by way of an e-mail to such e-mail address. Where the Municipality transmits and e-mail to such address, incorrect addresses due to legibility shall be the tenderers risk.
- 2.21.3.** Notwithstanding any request for confirmation of receipt of Addenda issued, the tenderer shall be deemed to have received such addenda if the Municipality can show proof of transmission thereof (or a notice in respect thereof) via electronic mail, facsimile or registered post.
- 2.21.4.** The Municipality may on reasonable grounds extend the closing date/time stated in the Tender Documents, by notifying all tenderers who drew or downloaded documents as set out in clause 2.23.2 above.

2.22. Invalid Tenders

The Bid Evaluation Committee shall consider the bids received and shall note for inclusion in the evaluation report a bidder whose tender is considered by the Bid Evaluation Committee to be invalid and eliminated from further evaluation for any of the following reasons:

- 2.22.1. the tender, including the tender amount, where applicable, is not submitted on the official Form of Offer
- 2.22.2. the tender document is not completed in non-erasable handwritten, or printed, ink or toner;
- 2.22.3. the Form of Offer has not been signed with an original signature
- 2.22.4. the Form of Offer (**Part A3**) is signed, but the name of the tenderer is not stated, or is indecipherable;
- 2.22.5. if in a two envelope system, the tenderer fails to submit a separately sealed financial offer/tender.

2.23. Non-Responsive Tenders

2.25.1. Valid tenders will be declared non-responsive and eliminated from further evaluation if:

- a) The tenderer has been listed on the National Treasury's Register for Tender Defaulters in terms of the Prevention and Combating of Corrupt Activities Act, Act 12 of 2004, or has been listed on the National Treasury's List of Restricted Suppliers and who is therefore prohibited from doing business with the public sector.
- b) The tenderer is prohibited from doing business with the Nama Khoi municipality in terms of the SCM Policy.
- c) The tender does not comply with the specification(s) (**Part D1**).
- d) The tender does not comply with the instructions as contained in the Price Schedule (**Part C1**) and/or **Schedule B14: Contract Price Adjustment and Rate of Exchange Variation** (where applicable).
- e) The tenderer is a person, advisor or corporate entity involved with the Bid Specification Committee or director/member of such a corporate entity and is therefore prohibited from tendering for any resulting contracts.
- f) The tenderer does not submit prices for all Items.
- g) The tenderer does not submit firm prices of the contract. (As indicated in the Price Schedule)

2.25.2. Tenders will be declared non-responsive if the tenderer fails to adhere to a written request (within the specified period set out in such request) to:

- a) Comply with the general conditions applicable to tenders as set out in the SCM Policy;
- b) Comply with one or more of the provisions contained in the Conditions of Tender;
- c) Comply with any other terms and conditions of the tender as contained in the tender document;
- d) Complete and/or sign any declarations and/or authorizations;
- e) Register on the Central Supplier Database;
- f) Submit an original and valid tax clearance certificate from the South African Revenue Services (SARS) certifying that the taxes of the tenderer are in order;
- g) Comply with any applicable Bargaining Council agreements;
- h) Submit the information/complete **Part B5** in respect of transaction values exceeding R10 million (see Conditions of Tender).
- i) Submit brochures of their product (preferably with their Tender Document) or within 7 days from date of request thereof.

2.25.3. Clause 2.25.2 above is not a closed list, and requests may include but are not limited to – the items referred to in a) to i) above.

2.24. Evaluation of Tenders

- 2.26.1. All tenders received shall be evaluated in accordance with the Municipal Finance Management Act, Act 56 of 2003 (read with its accompanying Supply Chain Management Regulations), Nama Khoi Municipality's SCM Policies, and the Preferential Procurement Policy Framework Act, Act 5 of 2000 (read with its accompanying regulations).
- 2.26.2. Points for price will be allocated in accordance with the formula stipulated in legislation above, 80/20 based on the sum of the prices in relation to the estimated quantities. Bids may be awarded to different tenderers. 20 Points will be awarded for Specific Goals.

2.25. Local production and content

Not Applicable

2.26. COIDA

- 2.29.1. The Tender shall submit a Letter of Good Standing issued in terms of COIDA, confirming that the Tenderer is registered as an employer in terms of the provisions of the Compensation for Occupational Injuries and Diseases Act, No. 130 of 1993.
- 2.29.2. Tenderers must, within 14 days of being requested to do so submit Letter of Good Standing issued in terms of COIDA, confirming that the Tenderer is registered as an employer in terms of the provisions of the Compensation for Occupational Injuries and Diseases Act, No. 130 of 1993.

2.27. Negotiations with preferred bidders

- 2.30.1. The Municipal Manager (or his delegated authority) may authorize the negotiation of the final terms of a contract with tenderers identified through a competitive bidding process as preferred tenderer provided that such negotiation:
- (a) does not allow any preferred tenderer a second or unfair opportunity;
 - (b) is not to the detriment of any other tenderer; and
 - (c) does not lead to a higher price than the tender as submitted.
- 2.30.2. Minutes of such negotiations must be kept for record purposes.
- 2.30.3. If negotiations fail to result in acceptable contract terms, the Municipal Manager (or his delegated authority) may terminate the negotiations and invite the next ranked tenderer for negotiations. The original preferred tenderer should be informed of the reasons for termination of the negotiations. Once negotiations are commenced with the next ranked tenderer, earlier negotiations may not be reopened by the Nama Khoi Municipality.
- 2.30.4. The provisions of clauses 2.30.1 to 2.31.3 shall apply to the invitation to negotiate of the next ranked tenderer, mutatis mutandis.

2.28. Objections, complaints, queries and disputes/ Appeals in terms of Section 62 of the Systems Act/ Access to court

2.31.1. Objections, complaints, queries and disputes

Persons aggrieved by decisions or actions taken by the Municipality in the implementation of the supply chain management system or any matter arising from a contract awarded in terms of the supply chain management system may, within 14 days of the decision or action, lodge a written objection or complaint or query or dispute against the decision or action.

2.31.2. Section 62 Appeals

- a) In terms of Section 62 of the Systems Act (Municipal Systems Act, Act 32 of 2000), a person whose rights are affected by a decision taken by a political structure, political office bearer, councilor or staff member of a municipality in terms of a power or duty delegated or sub-delegated by a delegating authority may appeal against that decision by giving written notice of the appeal and reasons to the Municipal Manager within 21 days of the date of the notification of the decision.
- b) An appeal shall contain the following:
 - i. The reasons and/or grounds for the appeal;
 - ii. The way in which the appellant's rights have been affected;
 - iii. The remedy sought by the appellant.

3.32.1. Access to court

The clauses above do not influence any person's rights to approach the High Court at any time or their rights in terms of the Promotion of Administrative Justice Act, Act 3 of 2000 ('PAJA'), or the Promotion of Access to Information Act, Act 2 of 2000 ('PAIA')

2.29. Tacking action due to non-performance

Where the employer terminates the contract due to default of the contractor or supplier in whole or in part, the employer may decide may impose a restriction penalty on the contractor in terms of Section 13 of the Preferential Procurement Regulations on supplier or contractor.

2.30. Arithmetical errors, omissions and discrepancies

2.33.1. Check responsive tenders for discrepancies between amounts in words and amounts in figures. Where there is a discrepancy between the amounts in figures and the amount in words, the amount in words shall govern.

2.33.2. Check the highest ranked tender or tenderer with the highest number of tender evaluation points after the evaluation of tender offers, for:

- a) the gross misplacement of the decimal point in any unit rate;
- b) omissions made in completing the pricing schedule or bills of quantities; or.
- c) arithmetic errors in:
 - i) line item totals resulting from the product of a unit rate and a quantity in bills of quantities or schedules of prices; or
 - ii) the summation of the prices.

2.33.3. Notify the tenderer of all errors or omissions that are identified in the tender offer and invite the tenderer to either confirm the tender offer as tendered or accept the corrected total of prices.

2.33.4. Where the tenderer elects to confirm the tender offer as tendered, correct the errors as follows:

- a) If bills of quantities or pricing schedules apply and there is an error in the line item total resulting from the product of the unit rate and the quantity, the line item total shall govern and the rate shall be corrected.
- b) Where there is an obviously gross misplacement of the decimal point in the unit rate, the line item total as quoted shall govern, and the unit rate shall be corrected.
- c) Where there is an error in the total of the prices either as a result of other corrections required by this checking process or in the tenderer's addition of prices, the total of the prices shall govern and the tenderer will be asked to revise selected item prices (and their rates if bills of quantities apply) to achieve the tendered total of the prices.

(3). TENDER OFFER

NOTICE NO.: 101/2025
BID NUMBER: BID/NC062/18/2025-2026

Starting Date: 21/11/ 2025

Closing Date: 05/12/ 2025

Closing Time: 12:00 Midday

3.1. I, _____ (duly authorized to represent the bidder for the purpose of this tender), hereby tender to supply all or any of the goods and/or render all or any of the services described in the attached document to Nama Khoi Municipality on the terms and conditions stipulated in this tender document and in accordance with the specification stipulated in the tender document at the prices reflected in the *Contract Form/Price Schedule*.

3.2. The bidder agrees that:

3.2.1. the tender offer submitted shall remain valid, irrevocable and open for written acceptance by Nama Khoi Municipality for a period of 90 days from the closing date or for such extended period as may be applicable;

3.2.2. the tender offer will not be withdrawn or amended during the aforesaid validity period;

3.2.3. notwithstanding the above, the bidder may submit a written request to Nama Khoi Municipality after the closing date for permission to withdraw the tender offer. Such withdrawal will be permitted or refused at the sole discretion of the Nama Khoi Municipality after consideration of the reasons for the withdrawal, which shall be fully set out by the bidder in the written request for withdrawal;

3.2.4. should the tender offer be withdrawn in contravention of 3.2.1 to 3.2.3 above, the bidder agrees that

(a) it shall be liable to Nama Khoi Municipality for any additional expense incurred by the Nama Khoi Municipality in having either to accept another tender or, if new tenders have to be invited, the additional expenses incurred by the invitation of new tenders and the subsequent acceptance of any other tender;

(b) Nama Khoi Municipality shall also have the right to recover such additional expenses by set-off against monies which may be due or become due to the bidder under this or any other tender or contract or against any guarantee or deposit that may have been furnished by the bidder or on its behalf for the due fulfilment of this or any other tender or contract. Pending the ascertainment of the amount of such additional expenses, Nama Khoi Municipality shall be entitled to retain such moneys, guarantee or deposit as security for any loss Nama Khoi Municipality may suffer due to such withdrawal.

3.3. The bidder agrees that this tender and its acceptance shall be subject to the terms and conditions contained in the Supply Chain Management Policy ('SCM Policy').

Signature(s)

Print name(s):

On behalf of the bidder/ Contractor (duly authorized)

Date _____

(4). TENDER ACCEPTANCE

NOTICE NO.: 101/2025
BID NUMBER: BID/NC062/18/2025-2026

Starting Date: 21/11/2025

Closing Date: 05/12/ 2025

Closing Time: 12:00 Midday

By signing this part of Offer and Acceptance, the Employer identified below accepts the offer of the Contractor/ Service Provider. In consideration thereof, the Employer shall pay the Contractor the amount due in accordance with the Conditions of Contract identified in the Contract Data. Acceptance of the offer of the Service Provider shall form an agreement between the Employer and the Service Provider upon the terms and conditions contained in this Agreement and in the Contract that is subject of this Agreement.

The terms of the contract, are contained in
Part B Schedules
Part C Pricing Data
Part D Agreement and Contract Data, *(which includes this Agreement)*
Part E Scope of Work
Part F Site Information and drawings and documents

Deviations from and amendments to the documents listed in the quotation data and any addenda thereto listed in the Contractor schedules as well as any changes to the terms of the Offer agreed by the Tenderer and the Employer during this process of offer and acceptance, are contained in the Schedule of Deviations attached to and forming part of this Agreement. No amendments to or deviations from said documents are valid unless contained in this Schedule, which must be duly signed by the authorized representative(s) of both parties.

The Service Provider shall within 14 calendar days after receiving a completed copy of this Agreement, including the Schedule of Deviations (if any), contact the Employer's agent (whose details are given in the Bid document) to arrange the delivery of any bonds, guarantees, proof of insurance and any other documentation to be provided in terms of the Conditions of Contract identified in the Contract at, or just after, the date this Agreement comes into effect. Failure to fulfill any of these obligations in accordance with those terms shall constitute a repudiation of this Agreement.

Notwithstanding anything contained herein, this Agreement come into effect on the date when the contractor receives one fully completed copy of this document, including the Schedule of Deviations (if any). Unless the Service Provider (now Contractor) within five days of the date of such receipt notifies the Employer in writing of any reason why he cannot accept the contents of this Agreement, this Agreement shall constitute a binding contract between the parties,

Signature(s)

Print name(s):

On behalf of Nama Khoi Municipality (duly authorized)

Date_____



(PART B) RETURNABLE DOCUMENTS AND SCHEDULES

1. INVITATION TO BID (MBD 1)
2. ORIGINAL TAX CLEARANCE CERTIFICATE REQUIREMENTS (MBD 2)
3. PRICING SCHEDULE – FIRM PRICES (CONSTRUCTION WORKS) (MBD 3.1)
4. DECLARATION OF INTEREST – EMPLOYEES IN THE SERVICE OF THE STATE (MBD 4)
5. DECLARATION FOR PROCUREMENT ABOVE R 10 MILLION (ALL TAXES INCLUDED) (MBD 5) - NOT APPLICABLE FOR THIS BID
6. PREFERENCE POINTS CLAIM IN TERMS OF THE PREFERENTIAL PROCUREMENT REGULATIONS (MBD 6.1)
7. LOCAL CONTENT (MBD 6.2) - NOT APPLICABLE FOR THIS BID
8. CONTRACT FORM – PURCHASES (MBD 7.1)
9. DECLARATION OF BIDDER’S PAST SUPPLY CHAIN MANAGEMENT PRACTICES (MBD 8)
10. CERTIFICATE OF INDEPENDENT BID DETERMINATION (MBD 9)
11. DECLARATION ON STATE OF MUNICIPAL ACCOUNTS AT ALL MUNICIPALITIES (SCM 1)
12. AUTHORISATION FOR DEDUCTION OF MUNICIPAL SERVICES AND PAYMENTS OWED TO NAMA KHOI MUNICIPALITY (SCM 2)
13. CERTIFICATE OF AUTHORITY FOR INCORPORATED OR UNINCORPORATED JOINT VENTURE (JV), CONSORTIUMS AND PARTNERSHIPS
14. CONTRACT PRICE ADJUSTMENT - NOT APPLICABLE FOR THIS BID
15. SUPPLY CHAIN MANAGEMENT AND REGULATION 12 PREFERENTIAL PROCUREMENT REGULATIONS DECLARATION
16. RESOLUTION BY DIRECTOR/MEMBERS/TRUSTEES
17. WARRANTY
18. LIST OF AUTHORISED FINANCIAL INSTITUTIONS – CONTRACT SURETIES
19. CONFLICT OF INTEREST DECLARATION – GIFTS AND SPONSORSHIPS
20. LIST OF ALTERNATIVE OFFERS/ DEVIATIONS - NOT APPLICABLE FOR THIS BID
21. LETTER OF GOOD STANDING (COIDA) - NOT APPLICABLE FOR THIS BID
22. LIST OF OTHER DOCUMENTATION ATTACHED BY BIDDER

(1) INVITATION TO BID (MBD 1)

NOTICE NO.: 101/2025
BID NUMBER: BID/NC062/18/2025-2026

Starting Date: 21/11/2025

Closing Date: 05/12/2025

Closing Time: 12:00 Midday

PART A INVITATION TO BID

YOU ARE HEREBY INVITED TO BID FOR REQUIREMENTS OF THE (NAME OF MUNICIPALITY/ MUNICIPAL ENTITY)					
BID NUMBER:	BID/NC062/18/2025-2026	CLOSING DATE:	05 December2025	CLOSING TIME:	12:00 Midday
DESCRIPTION	SUPPY AND DELIVERY OF HOUSE CONNECTION MATERIAL				
THE SUCCESSFUL BIDDER WILL BE REQUIRED TO FILL IN AND SIGN A WRITTEN CONTRACT FORM (MBD7).					

BID RESPONSE DOCUMENTS MAY BE DEPOSITED IN THE TENDER BOX
 SITUATED AT (STREET ADDRESS)

Nama Khoi Municipality, 4 Namaqua Street, Springbok, 8240

SUPPLIER INFORMATION

NAME OF BIDDER				
POSTAL ADDRESS				
STREET ADDRESS				
TELEPHONE NUMBER	CODE		NUMBER	
CELLPHONE NUMBER				
FACSIMILE NUMBER	CODE		NUMBER	
E-MAIL ADDRESS				
VAT REGISTRATION NUMBER				
TAX COMPLIANCE STATUS	TCS PIN:		OR	CSD No:

Specific Goals:

The bidder must submit the following three (3) documents to earn points out of 10 for the specific goal 1: % Black ownership

1. Service Provider must submit proof of ownership of the enterprise or
1. Ownership Certificate issued by the Companies and Intellectual Property Commission
2. Affidavit stating the race and % of the company's owner(s)
3. Certified ID (not older than 6 months)

Failure to submit all 3 documents will result in 0 points allocation for specific goal 1.

The bidder must submit the following documents to earn points out of 10 for specific goal 2: Locality

1. Service Provider must submit proof of address with a municipal account or
2. Proof of registered business address

Note: Nama Khoi Local Municipality will reserve the right to use all available information at its disposal including conducting site visits and inspections to verify a bidder's claim of having a local office within the Nama Khoi Municipal Area.

Note: Failure to submit the above-mentioned proof of address documents will result in 0 points allocation for specific goal 2.

Attached

Yes

No

Attached

Yes

No

ARE YOU THE ACCREDITED REPRESENTATIVE IN SOUTH AFRICA FOR THE GOODS /SERVICES /WORKS OFFERED?	<input type="checkbox"/> Yes <input type="checkbox"/> No [IF YES ENCLOSE PROOF]	ARE YOU A FOREIGN BASED SUPPLIER FOR THE GOODS /SERVICES /WORKS OFFERED?	<input type="checkbox"/> Yes <input type="checkbox"/> No [IF YES, ANSWER PART B:3]
TOTAL NUMBER OF ITEMS OFFERED		TOTAL BID PRICE	R
SIGNATURE OF BIDDER	DATE	
CAPACITY UNDER WHICH THIS BID IS SIGNED			
BIDDING PROCEDURE ENQUIRIES MAY BE DIRECTED TO:		TECHNICAL INFORMATION MAY BE DIRECTED TO:	
DEPARTMENT	Supply Chain Management Unit	DEPARTMENT	Technical Services
CONTACT PERSON	Candice Rabie	CONTACT PERSON	Johannes Adams
TELEPHONE NUMBER	027 718 8210	TELEPHONE NUMBER	027 718 8100
E-MAIL ADDRESS	candice.rabie@namakhoi.gov.za	E-MAIL ADDRESS	johannes.adams@namakhoi.gov.za

**PART B
TERMS AND CONDITIONS FOR BIDDING**

1. BID SUBMISSION:	
1.1.	BIDS MUST BE DELIVERED BY THE STIPULATED TIME TO THE CORRECT ADDRESS. LATE BIDS WILL NOT BE ACCEPTED FOR CONSIDERATION.
1.2.	ALL BIDS MUST BE SUBMITTED ON THE OFFICIAL FORMS PROVIDED–(NOT TO BE RE-TYPED) OR ONLINE
1.3.	THIS BID IS SUBJECT TO THE PREFERENTIAL PROCUREMENT POLICY FRAMEWORK ACT AND THE PREFERENTIAL PROCUREMENT REGULATIONS, 2017, THE GENERAL CONDITIONS OF CONTRACT (GCC) AND, IF APPLICABLE, ANY OTHER SPECIAL CONDITIONS OF CONTRACT.
2. TAX COMPLIANCE REQUIREMENTS	
2.1	BIDDERS MUST ENSURE COMPLIANCE WITH THEIR TAX OBLIGATIONS.
2.2	BIDDERS ARE REQUIRED TO SUBMIT THEIR UNIQUE PERSONAL IDENTIFICATION NUMBER (PIN) ISSUED BY SARS TO ENABLE THE ORGAN OF STATE TO VIEW THE TAXPAYER'S PROFILE AND TAX STATUS.
2.3	APPLICATION FOR THE TAX COMPLIANCE STATUS (TCS) CERTIFICATE OR PIN MAY ALSO BE MADE VIA E-FILING. IN ORDER TO USE THIS PROVISION, TAXPAYERS WILL NEED TO REGISTER WITH SARS AS E-FILERS THROUGH THE WEBSITE WWW.SARS.GOV.ZA.
2.4	FOREIGN SUPPLIERS MUST COMPLETE THE PRE-AWARD QUESTIONNAIRE IN PART B:3.
2.5	BIDDERS MAY ALSO SUBMIT A PRINTED TCS CERTIFICATE TOGETHER WITH THE BID.
2.6	IN BIDS WHERE CONSORTIA / JOINT VENTURES / SUB-CONTRACTORS ARE INVOLVED, EACH PARTY MUST SUBMIT A SEPARATE TCS CERTIFICATE / PIN / CSD NUMBER.
2.7	WHERE NO TCS IS AVAILABLE BUT THE BIDDER IS REGISTERED ON THE CENTRAL SUPPLIER DATABASE (CSD), A CSD NUMBER MUST BE PROVIDED.
3. QUESTIONNAIRE TO BIDDING FOREIGN SUPPLIERS	
3.1.	IS THE ENTITY A RESIDENT OF THE REPUBLIC OF SOUTH AFRICA (RSA)? <input type="checkbox"/> YES <input type="checkbox"/> NO
3.2.	DOES THE ENTITY HAVE A BRANCH IN THE RSA? <input type="checkbox"/> YES <input type="checkbox"/> NO
3.3.	DOES THE ENTITY HAVE A PERMANENT ESTABLISHMENT IN THE RSA? <input type="checkbox"/> YES <input type="checkbox"/> NO
3.4.	DOES THE ENTITY HAVE ANY SOURCE OF INCOME IN THE RSA? <input type="checkbox"/> YES <input type="checkbox"/> NO
3.5.	IS THE ENTITY LIABLE IN THE RSA FOR ANY FORM OF TAXATION? <input type="checkbox"/> YES <input type="checkbox"/> NO
IF THE ANSWER IS "NO" TO ALL OF THE ABOVE, THEN IT IS NOT A REQUIREMENT TO REGISTER FOR A TAX COMPLIANCE STATUS SYSTEM PIN CODE FROM THE SOUTH AFRICAN REVENUE SERVICE (SARS) AND IF NOT REGISTER AS PER 2.3 ABOVE.	

**NB: FAILURE TO PROVIDE ANY OF THE ABOVE PARTICULARS MAY RENDER THE BID INVALID.
NO BIDS WILL BE CONSIDERED FROM PERSONS IN THE SERVICE OF THE STATE.**

SIGNATURE OF BIDDER:

CAPACITY UNDER WHICH THIS BID IS SIGNED:

DATE:

(2) TAX CLEARANCE CERTIFICATE REQUIREMENTS (MBD 2)

NOTICE NO.: 101/2025
BID NUMBER: BID/NC062/18/2025-2026

Starting Date: 21/11/ 2025

Closing Date: 05/12 2025

Closing Time: 12:00 Midday

- 2.1. It is a condition of bid that the taxes of the successful bidder must be in order, or that satisfactory arrangements have been made with South African Revenue Service (SARS) to meet the bidder's tax obligations.
- 2.2. In order to meet this requirement bidders are required to complete in full the form TCC 001 "Application for a Tax Clearance Certificate" and submit it to any SARS branch office nationally. The Tax Clearance Certificate Requirements are also applicable to foreign bidders / individuals who wish to submit bids.
- 2.3. SARS will then furnish the bidder with a Tax Clearance Certificate that will be valid for a period of 1 (one) year from the date of approval.
- 2.4. The original Tax Clearance Certificate must be submitted together with the bid. Failure to submit the original and valid Tax Clearance Certificate will result in the invalidation of the bid. Certified copies of the Tax Clearance Certificate will not be acceptable.
- 2.5. In bids where Consortia / Joint Ventures / Sub-contractors are involved, each party must submit a separate Tax Clearance Certificate.
- 2.6. Copies of the TCC 001 "Application for a Tax Clearance Certificate" form are available from any SARS branch office nationally or on the website www.sars.gov.za.
- 2.7. Applications for the Tax Clearance Certificates may also be made via eFiling. In order to use this provision, taxpayers will need to register with SARS as eFilers through the website www.sars.gov.za.
- 2.8. Nama Khoi Municipality reserves the right to check with SARS if a tax certificate is valid or not.
- 2.9. Attached original tax certificate to this returnable schedule.

(3) DECLARATION OF INTEREST (MBD 4)

NOTICE NO.: 101/2025
BID NUMBER: BID/NC062/18/2025-2026

Starting Date: 21/11/2025

Closing Date: 05/12/ 2025

Closing Time: 12:00 Midday

- 4.1. No bid will be accepted from persons in the service of the state*.
- 4.2. Any person, having a kinship with persons in the service of the state, including a blood relationship, may make an offer or offers in terms of this invitation to bid. In view of possible allegations of favoritism, should the resulting bid, or part thereof, be awarded to persons connected with or related to persons in service of the state, it is required that the bidder or their authorized representative declare their position in relation to the evaluating/adjudicating authority and/or take an oath declaring his/her interest.
- 4.3. In order to give effect to the above, the following questionnaire must be completed and submitted with the bid.
- 4.3.1 Full Name of enterprise:
- 4.3.2 Physical address of local office:
- 4.3.3 Identity Number if sole proprietor:.....
- 4.3.4 Company Registration Number:.....
- 4.3.5 Tax Reference Number:
- 4.3.6 VAT Registration Number, if any:.....
- 4.4. The names of all directors / trustees / shareholders members, their individual identity numbers and state employee numbers must be indicated in paragraph 4 below.
- 4.5. Are you presently in the service of the state **YES / NO** *

If so, furnish particulars.

- 4.6. Have you been in the service of the state for the past twelve months? **YES / NO**

* MSCM Regulations: "in the service of the state" means to be -

- (a) a member of -
 - (i) any municipal council;
 - (ii) any provincial legislature; or
 - (iii) the national Assembly or the national Council of provinces;
- (b) a member of the board of directors of any municipal entity;
- (c) an official of any municipality or municipal entity;
- (d) an employee of any national or provincial department, national or provincial public entity or constitutional institution within the meaning of the Public Finance Management Act, 1999 (Act No.1 of 1999);
- (e) a member of the accounting authority of any national or provincial public entity; or
- (f) an employee of Parliament or a provincial legislature.

If so, furnish particulars.

4.7. Do you, have any relationship (family, friend, other) with persons in the service of the state and who may be involved with the evaluation and or adjudication of this bid? **YES / NO**

If so, furnish particulars.

4.8. Are you, aware of any relationship (family, friend, other) between a bidder and any persons in the service of the state who may be involved with the evaluation and or adjudication of this bid? **YES / NO**

If so, furnish particulars.

4.9. Are any of the entity directors, managers, principle shareholders or stakeholders in service of the state? **YES / NO**

If so, furnish particulars.

4.10. Are any spouse, child or parent of the company's directors, managers, principle shareholders or stakeholders in service of the state? **YES / NO**

If so, furnish particulars.

4.11. Do you or any of the directors, trustees, managers, principle shareholders, or stakeholders of this entity have any interest in any other related companies or business whether or not they are bidding for this contract . **YES / NO**

If so, furnish particulars.

4.12. Full details of all the directors / trustees / members / shareholders.

Full Name of sole proprietor, partner, director, Manager, principal shareholder or stakeholder or member	ID Number	Name of Organ of state	Income Tax Number (Compulsory)	State Employee Number	
				Current	Within past 12 months

(4)

**DECLARATION FOR PROCUREMENT / SERVICES ABOVE R10 MILLION
(ALL APPLICABLE TAXES INCLUDED) (MBD 5)**

NOT APPLICABLE

NOTICE NO.: 101/2025

BID NUMBER: BID/NC062/18/2025-2026

Starting Date: 21/11/ 2025

Closing Date: 05/12/2025

\ Closing Time: 12:00 Midday

All procurement contracts expected to **exceed R10 million (all applicable taxes included)**, bidders must complete the following questionnaire and attached the necessary documentation:

5.1. Are you by law required to prepare annual financial statement for auditing? *YES / NO

5.1. If yes, submit audited annual financial statements for the past three years or since the date of establishment if established during the past three years.

5.2. Do you have any outstanding undisputed commitments for municipal services towards any municipality for more than three months or any other service provider in respect of which payment is overdue for more than 30 days? *YES / NO

5.2.1 If no, this serves to certify that the bidder has no undisputed commitments for municipal services towards any municipality for more than three months or other service provider in respect of which payment is overdue for more than 30 days.

5.2.2 If yes, provide particulars

5.3. Has any contract been awarded to you by an organ of state during the past 5 (five) years, including particulars of any material non-compliance or dispute concerning the execution of such contract? *YES / NO

5.3.1 If yes, furnish particulars

5.4. Will any portion of goods or services be sourced from outside the Republic, and, if so, what portion and whether any portion of payment from the municipality is expected to be transferred out of the Republic. *YES / NO

The bidder hereby certifies that the information set out in this schedule and/or attached thereto is true and correct, and acknowledges that failure to properly and truthfully complete this schedule may result in the tender being disqualified, and/or (in the event that the bidder is successful) the cancellation of the contract.

PRINT FULL NAME: _____ **DATE :** _____

SIGNATURE: _____

(5) PREFERENCE POINTS CLAIM FORM IN TERMS OF THE PREFERENTIAL PROCUREMENT REGULATIONS (MBD 6.1)

NOTICE NO.: 101/2025
BID NUMBER: BID/NC062/18/2025-2026

Starting Date: 21/11/2025

Closing Date: 05/12/ 2025

Closing Time: 12:00 Midday

This preference form must form part of all bids invited. It contains general information and serves as a claim form for preference points as indicated below.

PREFERENCE POINTS CLAIM FORM IN TERMS OF THE PREFERENTIAL PROCUREMENT POLICY OF NAMA KHOI MUNICIPALITY

This preference form must form part of all bids invited.

This tender is issued in accordance with the accordance with the Preferential Procurement Regulations, 2022, issued under the Preferential Procurement Policy of Nama Khoi Local Municipality, preference points will be awarded based on a combination of price and specific goals identified in this bid document (MBD6.1).

While the bidder with the lowest acceptable price will score the highest points for price, the final award will be based on the highest overall points scored out of 100 – combining both price and specific goals. This ensures that the procurement process is not only cost effective but also transformative, equitable and aligned with the municipality's developmental priorities.

NB: BEFORE COMPLETING THIS FORM, BIDDERS MUST STUDY THE GENERAL CONDITIONS, DEFINITIONS AND DIRECTIVES APPLICABLE IN RESPECT OF PRICING AND SPECIFIC – GOALS, AS PRESCRIBED IN THE PREFERENTIAL PROCUREMENT REGULATIONS, 2022.

1. GENERAL CONDITIONS

The formula to be utilised in calculating points scored for price are as follows (This applies to procurement of goods and services):

1.1 80/20 Preference point system [(for acquisition of goods or services for a Rand value equal to or below R50 million) (all applicable taxes included)]

$$P_s = 80 \left(1 - \frac{(P_t - P_{min})}{P_{min}} \right)$$

Where -

- P_s = Points scored for price of tender under consideration
- P_t = Price of tender under consideration
- P_{min} = Price of lowest acceptable tender.

- A maximum of 20 points may be awarded to a tenderer for the specified goals for the tender.
- The points scored for the specific goal must be added to the points scored for price and the total must be rounded off to the nearest two decimal place.
- Subject to section 2(1)(f) of the Act, the contract must be awarded to the tenderer scoring the highest points.

1.2. 90/10 Preference point system [(for acquisition of goods or services with a Rand value above R50 million) (all applicable taxes included)]

$$P_s = 90 \left(1 - \frac{(P_t - P_{min})}{P_{min}} \right)$$

Where:

- P_s = Points scored for price of tender under consideration
- P_t = Price of tender under consideration
- P_{min} = Price of lowest acceptable tender.
- A maximum of 10 points may be awarded to a tenderer for the specified goals for the tender.
- The points scored for the specific goal must be added to the points scored for price and the total must be rounded off to the nearest two decimal places.
- Subject to section 2(1)(f) of the Act, the contract must be awarded to the tenderer scoring the highest points.

1.3. Points for specific goals to promote economic development

The points scored for price must be added to the points scored for specific goals to obtain the bidder's total points scored out of a 100. A bid must not be disqualified from the bidding process if the bidder does not submit the required supporting documents. Such a bidder will score 0 out of 10 points for specific goal 1.

- (a) **Points for Specific Goals to include contracting with persons or categories of persons historically disadvantaged by unfair discrimination based on race will be allocated as follows:**

Note: Allocation of preference points based on specific goals chosen by an organ of state. In terms of Section 2(1)(b)(i) and (ii) state that 10 or 20 points may be allocated for specific goals as contemplated in paragraph (d). Therefore, in aligning the regulations with the Act, preference points must be allocated in terms of the specific goals as required by the Act.

SPECIFIC GOAL 1: Persons historically disadvantaged on the basis of race	Points Allocation	
	80/20	90/10
100% black owned	10	5
75% - 99% black ownership	8	4
60% - 74% black ownership	6	3
51% - 59% black ownership	4	2
0% - 50% black ownership	0	0

(b) **Points for Specific goals to promote economic development (Locality) will be allocated as follows:**

SPECIFIC GOAL 2: Local area of supplier	Points Allocation	
	80/20	90/10
Within the boundaries of the Nama Khoi Municipality	10	5
Within the boundaries of Namakwa District Municipality	8	4
Within the boundaries of the Northern Cape	6	3
Within the boundaries of South Africa	4	2
Outside of the boundaries of South Africa	0	0

a) The specification committee will make proposals if functionality points need to be used and the evaluation committee will approve a variation in the point system for a specific bid.

b) For construction procurements the CIDB Act and Regulations are to be used for quotations / bids.

- Any specific goal for which a point may be awarded, must be clearly specified in the invitation to submit a tender.
- A tenderer failing to submit proof of required evidence to claim preferences for other specified goals, which is in line with section 2 (1) (d) (ii) of the Act.
- Any combination of specific goals in Section 2(1)(d)(i) and (ii) may be used and the points must either add up to 10 points (for the 90/10 preference point system) or 20 points (for the 80/20 preference point system).

2. BID DECLARATION

2.1. Bidders who claim points in respect of Pricing and Specific Goals must complete the following documents to earn points:

(a) SPECIFIC GOAL 1: Persons historically disadvantaged on the basis of race ((3) three documents:

- Service Provider must submit proof of ownership of the enterprise or
- Ownership Certificate issued by the Companies and Intellectual Property Commission
- Affidavit stating the race and % of the company's owner(s)
- Certified ID (not older than 6 months)

PLEASE COMPLETE AFFIDAVIT BELOW AND SUBMIT WITH ABOVE REQUIRED DOCUMENTS:

Note: Failure to submit all 3 documents will result in 0 points allocation for specific goal 1.

(b) SPECIFIC GOAL 2: Local area of supplier

- Service Provider must submit proof of address with a municipal account or
- Proof of registered business address
- Note: Nama Khoi Local Municipality will reserve the right to use all available information at its disposal including conducting site visits and inspections to verify a bidder's claim of having a local office within the Nama Khoi Municipal Area.

Note: Failure to submit the above-mentioned proof of address documents will result in 0 points allocation for specific goal 2.



Nama Khoi Local Municipality

Posbus / P. O. Box 17
 Privaatsak / Private Bag X22
 SPRINGBOK, 8240
 TEL: 027 718 8100
 FAX: 027 712 1635
 EMAIL: info@namakhoi.gov.za
 WEB: <https://www.namakhoi.gov.za/>

- Alle korrespondensie moet gerig word aan die: KANTOOR VAN DIE **MUNISIPALE BESTUURDER**
- All correspondence to be addresses to the: OFFICE OF THE **MUNICIPAL MANAGER**
- Yonke imbalelwano mayithunyelwe kwi: I-OFISI **YOMPHATHI KAMASIPALA**

VISION: Building tomorrow, today.
MISSION: To deliver outstanding services to the community and to stimulate economic development in the region with the focus on the previously disadvantaged.

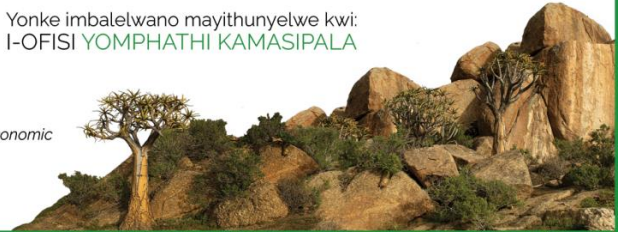

SWORN AFFIDAVIT – % BLACK OWNERSHIP

I, the undersigned,

Full name & Surname	
Identity number	

Hereby declare under oath as follows:

1. The contents of this statement are to the best of my knowledge a true reflection of the facts.
2. I am an Owner of the following enterprise and am duly authorised to act on its behalf:

ENTERPRISE NAME:	
TRADING NAME (IF APPLICABLE):	
REGISTRATION NUMBER:	
VAT NUMBER:	
ENTERPRISE PHYSICAL ADDRESS:	
TYPE OF ENTITY (CC,(PTY)LTD, SOLE PROP etc.):	
NATURE OF BUSINESS:	

As per the B-BBEE Act, black people are defined as follows,

“black people” is a generic term which means Africans, Coloureds and Indians;

NO	OWNERS (FULL NAME AND SURNAME)	% OWNED IN COMPANY	RACE
1			
2			
3			
4			
5			
6			
7			
8			
9			
10			

BLACK OWNERSHIP DECLARATION FOR PROCUMENT EVALUATION	INDICATE (✖)/(✓)
100% BLACK OWNED	
75% - 99% BLACK OWNERSHIP	
60% - 74% BLACK OWNERSHIP	
51% - 59% BLACK OWNERSHIP	
0% - 50% BLACK OWNERSHIP	

- Based on the above table, I hereby declare under Oath that:
 - The Enterprise is _____% Black Owned.
- I know and understand the contents of this affidavit and I have no objection to take the prescribed oath and consider the oath binding on my conscience and on the Owners of the Enterprise which I represent in this matter.
- The sworn affidavit will be valid for a period of 6 months from the date signed by commissioner.

Deponent Signature: _____

Date : _____

 Commissioner of Oaths Signature & stamp Date:

**6. DECLARATION CERTIFICATE FOR LOCAL PRODUCTION AND
CONTENT FOR DESIGNATED SECTORS (MBD 6.2)**

NOT APPLICABLE

(7) CONTRACT FORM – PROCUREMENT OF SERVICES (MBD 7.2)

THIS FORM MUST BE FILLED IN DUPLICATE BY BOTH THE SUCCESSFUL BIDDER (PART 1) AND THE SERVICE PROVIDER (PART 2). BOTH FORMS MUST BE SIGNED IN THE ORIGINAL SO THAT THE SUCCESSFUL BIDDER AND THE SERVICE PROVIDER WOULD BE IN POSSESSION OF ORIGINALLY SIGNED CONTRACTS FOR THEIR RESPECTIVE RECORDS.

PART 1 (TO BE FILLED IN BY THE BIDDER)

1. I, _____, hereby undertake to supply all or any of the services described in the attached bidding documents to Nama Khoi Municipality in accordance with the requirements and specifications stipulated in bid number **BID/NC062/18/2025-2026** at the price/s quoted. My offer remain binding upon me and open for acceptance by the purchaser during the validity period indicated and calculated from the closing time of bid.

2. The following documents shall be deemed to form and be read and construed as part of this agreement:
 - (i) Bidding documents, viz
 - Invitation to bid;
 - Tax clearance certificate;
 - Pricing schedule(s);
 - Technical Specification(s);
 - Preference claims for Broad Based Black Economic Empowerment Status Level of Contribution in terms of the Preferential Procurement Regulations 2011;
 - Declaration of interest;
 - Declaration of bidder’s past SCM practices;
 - Certificate of Independent Bid Determination;
 - Special Conditions of Contract;
 - (ii) General Conditions of Contract; and
 - (iii) All other declarations part of the bid document

3. I confirm that I have satisfied myself as to the correctness and validity of my bid; that the price(s) and rate(s) quoted cover all the works specified in the bidding documents; that the price(s) and rate(s) cover all my obligations and I accept that any mistakes regarding price(s) and rate(s) and calculations will be at my own risk.

4. I accept full responsibility for the proper execution and fulfilment of all obligations and conditions devolving on me under this agreement as the principal liable for the due fulfillment of this contract.

5. I declare that I have no participation in any collusive practices with any bidder or any other person regarding this or any other bid.

6. I confirm that I am duly authorized to sign this contract.

NAME (PRINT)

CAPACITY

SIGNATURE

NAME OF FIRM

DATE

WITNESSES	
1
2.
DATE:

CONTRACT FORM – PROCUREMENT OF SERVICES (MBD 7.2) CONTINUED

**PART 2 COMPLETED BY NAMA KHOI MUNICIPLITY
TENDER NO: BID/NC062/18/2025-2026
SUPPLY AND DELIVERY OF HOUSE CONNECTION MATERIAL**

1. I, _____ in my capacity as Municipal Manager or delegated official of Nama Khoi Municipality accept your bid under reference number **BID/NC062/18/2025-2026** dated _____ for the supply of goods/services/works indicated hereunder and/or further specified in the annexure(s).
2. An official order indicating delivery instructions is forthcoming.
3. I undertake to make payment for the goods/works delivered in accordance with the terms and conditions of the contract, within 30 (thirty) days after receipt of an invoice accompanied by the delivery note.

ITEM NO.	DESCRIPTION OF SERVICES	PRICE (VAT INCL) R	CIDB	MINIMUM THRESHOLD FOR LOCAL PRODUCTION AND CONTENT (if applicable)
1.				N/A
	Sub - total (Excluding Taxes)			
	Taxes			
	Total (Included Taxes)			

4. I confirm that I am duly authorized to sign this contract.

SIGNED ATON.....

NAME (PRINT)

SIGNATURE

WITNESSES	
1.
2.
DATE

(8) DECLARATION OF BIDDER'S PAST SUPPLY CHAIN MANAGEMENT PRACTICES (MBD 8)

NOTICE NO.: 101/2025
BID NUMBER: BID/NC062/18/2025-2024

Starting Date: 21/11/2025

Closing Date: 05/12/2025

Closing Time: 12:00 Midday

- 9.1. This declaration is used by Nama Khoi Municipality in ensuring that when goods and services are being procured, all reasonable steps are taken to combat the abuse of the supply chain management system.
- 9.2. The bid of any bidder may be rejected if that bidder, or any of its directors have:
- (a) abused the municipality's / municipal entity's supply chain management system or committed any improper conduct in relation to such system;
 - (b) been convicted for fraud or corruption during the past five years;
 - (c) willfully neglected, reneged on or failed to comply with any government, municipal or other public sector contract during the past five years; or
 - (d) been listed in the Register for Tender Defaulters in terms of section 29 of the Prevention and Combating of Corrupt Activities Act (No 12 of 2004).
- 9.3. Where the entity tendering is a partnership/consortium/joint venture, each party to the partnership/ consortium/ joint venture must sign a declaration in terms of the Municipal Finance Management Act, Act 56 Of 2003, and attach it to this schedule.
- 9.4. In order to give effect to the above, the following questionnaire must be completed and submitted with the bid.

Item	Question	Yes	No
9.4.1	Is the bidder or any of its directors listed on the National Treasury's database as a company or person prohibited from doing business with the public sector? Persons who are listed on this database were informed in writing of this restriction by the National Treasury after the <i>audi alteram partem</i> rule was applied).	Yes <input type="checkbox"/>	No <input type="checkbox"/>
9.4.1.1	If so, furnish particulars:		
9.4.2	Is the bidder or any of its directors listed on the Register for Tender Defaulters in terms of section 29 of the Prevention and Combating of Corrupt Activities Act (No 12 of 2004)? To access this register enter the National Treasury's website, www.treasury.gov.za, click on the icon "Register for Tender Defaulters" or submit your written request for a hard copy of the Register to facsimile number (012) 3265445).	Yes <input type="checkbox"/>	No <input type="checkbox"/>
9.4.2.1	If so, furnish particulars:		
9.4.3	Was the bidder or any of its directors convicted by a court of law (including a court of law outside the Republic of South Africa) for fraud or corruption during the past five years?	Yes <input type="checkbox"/>	No <input type="checkbox"/>
9.4.3.1	If so, furnish particulars:		

9.4.4	Does the bidder or any of its directors owe any municipal rates and taxes or municipal charges to the municipality / municipal entity, or to any other municipality / municipal entity, that is in arrears for more than three months?	Yes <input type="checkbox"/>	No <input type="checkbox"/>
9.4.4.1	If so, furnish particulars:		
9.4.5	Was any contract between the bidder and the municipality / municipal entity or any other organ of state terminated during the past five years on account of failure to perform on or comply with the contract?	Yes <input type="checkbox"/>	No <input type="checkbox"/>
9.4.5.1	If so, furnish particulars:		

The bidder hereby certifies that the information set out in this schedule and/or attached thereto is true and correct, and acknowledges that failure to properly and truthfully complete this schedule may result in the tender being disqualified, and/or (in the event that the bidder is successful) the cancellation of the contract.

PRINT FULL NAME : _____ **DATE :** _____

SIGNATURE : _____

(9) CERTIFICATE OF INDEPENDENT BID DETERMINATION (MBD 9)

NOTICE NO.: 101/2025
BID NUMBER: BID/NC062/18/2025-2026

Starting Date: 21/11/2025

Closing Date: 05/12/2025

Closing Time: 12:00 Midday

I, _____, the undersigned, in submitting this bid, **Tender No.: BID/NC062/18/2025-2026, SUPPLY AND DELIVERY OF HOUSE CONNECTION** in response to the invitation for the bid made by Nama Khoi Municipality do hereby make the following statements that I certify to be true and complete in every respect:

I certify, on behalf of: _____ (Name of Bidder)

That:

1. I have read and I understand the contents of this Certificate;
2. I understand that the accompanying bid will be disqualified if this Certificate is found not to be true and complete in every respect;
3. I am authorized by the bidder to sign this Certificate, and to submit the accompanying bid, on behalf of the bidder;
4. Each person whose signature appears on the accompanying bid has been authorized by the bidder to determine the terms of, and to sign, the bid, on behalf of the bidder;
5. For the purposes of this Certificate and the accompanying bid, I understand that the word "competitor" shall include any individual or organization, other than the bidder, whether or not affiliated with the bidder, who:
 - (a) has been requested to submit a bid in response to this bid invitation;
 - (b) could potentially submit a bid in response to this bid, based on their qualifications, abilities or experience; and
 - (c) provides the same goods and services as the bidder and/or is in the same line of business as the bidder
6. The bidder has arrived at the accompanying bid independently from, and without consultation, communication, agreement or arrangement with any competitor. However communication between partners in a joint venture or consortium³ will not be construed as collusive bidding.
7. In particular, without limiting the generality of paragraphs 6 above, there has been no consultation, communication, agreement or arrangement with any competitor regarding:
 - (a) prices;
 - (b) geographical area where product or service will be rendered (market allocation)
 - (c) methods, factors or formulas used to calculate prices;
 - (d) the intention or decision to submit or not to submit, a bid;
 - (e) the submission of a bid which does not meet the specifications and conditions of the bid; or
 - (f) bidding with the intention not to win the bid.
8. In addition, there have been no consultations, communications, agreements or arrangements with any competitor regarding the quality, quantity, specifications and conditions or delivery particulars of the products or services to which this bid invitation relates.
9. The terms of the accompanying bid have not been, and will not be, disclosed by the bidder, directly or indirectly, to any competitor, prior to the date and time of the official bid opening or of the awarding of the contract.
10. I am aware that, in addition and without prejudice to any other remedy provided to combat any restrictive practices related to bids and contracts, bids that are suspicious will be reported to the Competition Commission for investigation and possible imposition of administrative penalties in terms of section 59 of the Competition Act No 89 of 1998 and or may be reported to the National Prosecuting Authority (NPA) for criminal investigation and or may be restricted from conducting business with the public sector for a period not exceeding ten (10) years in terms of the Prevention and Combating of Corrupt Activities Act No 12 of 2004 or any other applicable legislation.

PRINT FULL NAME : _____ **DATE :** _____

SIGNATURE : _____

(10) DECLARATION ON THE STATE MUNICIPAL ACCOUNTS AT ALL THE MUNICIPALITIES OF THE BIDDER (SCM1)

NOTICE NO.: 101/2025
BID NUMBER: BID/NC062/18/2025-2026

Starting Date: 21/11/2025

Closing Date: 05/12/2025

Closing Time: 12:00 Midday

11.1. The completion of this form is **COMPULSORY**, and failure to complete this form might result that this tender will not be considered.

11.2. The bidder:

- a) hereby acknowledges that according to SCM Regulation 38(1)(d)(i) the Municipal Manager may reject the tender of the bidder if any municipal rates and taxes or municipal service charges owed by the Bidder or any of its directors/members/partners to Nama Khoi Municipality, or to any other municipality or municipal entity, are in arrears for more than 3 (three) months; and
- b) therefore hereby agrees and authorizes the Nama Khoi Municipality to deduct the full amount outstanding by the bidder or any of its directors/members/partners from any payment due to the bidder; and
- c) confirms the following information for the purpose of giving effect to b) above;
- c) hereby certifies that the information set out in this schedule and/or attached thereto is true and correct. The bidder acknowledges that failure to properly and truthfully complete this schedule may result in the tender being disqualified, and/or (in the event that the bidder is successful) the cancellation of the contract. The bidder must complete or provide us with an additional schedule of information (Refer to schedule 14) in the following format;

Physical Business addresses of the Bidder	Municipality	Municipal Account Numbers

Attached certified copies of municipal accounts not older than 3 months.

11.3. The bidder must complete or provide us with an additional schedule of information (Refer to schedule 14) of all its directors/ shareholders/ Managers/ Partners/Members etc.

Name of Director/ Member	ID Number	Physical Address	Municipality	Municipal Account Number

Attached certified copies of municipal accounts all directors or members not older than 3 months.

I/We declare that the abovementioned information is true and correct and that the above mentioned documents refer to in 11.2 and 11.3 are attached to this form:

 (insert name of enterprise)

PRINT FULL NAME: _____

SIGNATURE: _____

DATE: _____

**(11) CERTIFICATE OF AUTHORITY FOR INCORPORATED OR
UNINCORPORATED JOINT VENTURE (JV), CONSORTIUMS AND
PARTNERSHIPS**

**NOTICE NO.: 101/2025
BID NUMBER: BID/NC062/18/2025-2026**

Starting Date: 21/11/2025

Closing Date: 05/12/2025

Closing Time: 12:00 Midday

This returnable schedule is to be completed if the tender is submitted by a partnership/consortium/joint venture.

13.1. We, the undersigned, are submitting this tender offer as a partnership/consortium/joint venture and hereby authorize, Mr./Ms. _____, of the authorized

entity _____,

acting in the capacity of lead partner, to sign all documents in connection with the tender offer and any contract resulting from it on the partnership/consortium/joint venture's behalf.

13.2. By signing this schedule the partners to the partnership/consortium/joint venture:

13.2.1 warrant that the tender submitted is in accordance with the main business and objectives of the partnership/consortium/joint venture;

13.2.2 agree that Nama Khoi Municipality shall make all payments in terms of this Contract into the following bank account of the partnership/consortium/joint venture;

Account Holder: _____

Financial Institution: _____

Branch Code: _____

Account No.: _____

13.2.3 agree that in the event that there is a change in the partnership/consortium/joint venture and/or should a dispute arise between the partnership/consortium/joint venture partners, that Nama Khoi Municipality shall continue to make any/all payments due and payable in terms of the Contract into the aforesaid bank account until such time as Nama Khoi Municipality is presented with a Court Order or an original agreement (signed by each and every partner of the partnership/consortium/joint venture) notifying Nama Khoi Municipality of the details of the new bank account into which it is required to make payment.

13.2.4 agree that they shall be jointly and severally liable to Nama Khoi Municipality for the due and proper fulfilment by the successful bidder/supplier of its obligations in terms of the Contract as well as any damages suffered by Nama Khoi Municipality as a result of breach by the successful bidder/supplier. The partnership/consortium/joint venture partners hereby renounce the benefits of exclusion and division.

13.3. All the information requested must be filled in the spaces provided. If additional space is required, additional sheets may be used and attached to the original documents.

13.4. A **copy of the joint venture agreement/consortium/ partnership** must be attached to this form, in order to demonstrate the Affirmable, Joint Venture Partner's share in the ownership, control, management responsibilities, risks and profits of the joint venture, the proposed joint venture agreement must include specific details relating to:

a) the contributions of capital and equipment

- b) work items to be performed by the Affirmable Joint Venture Partner's own forces
- c) work items to be performed under the supervision of the Affirmable Joint Venture Partner.

- 13.5. Copies of all written agreements between partners concerning the contract must be attached to this form including those, which relate to ownership options and to restrictions/limits regarding ownership and control.
- 13.6. The joint venture must be formalized. All pages of the joint venture agreement must be signed by all the parties concerned.
- 13.7. A letter/ notice of intention to formalize a **partnership/consortium/joint venture** once the contract has been awarded will not be considered.
- 13.8. Should any of the above not be complied with, the **partnership/consortium/joint venture** will be deemed null and void and will be considered non-responsive.
- 13.9. The **partnership/consortium/joint venture** must be registered with South African Revenue Services for VAT purposes in the event that the contract exceeds the registration threshold.
- 13.10. All the partners in a **partnership/consortium/joint venture** must provide a **original tax clearance certificate**.
- 13.11. The **partnership/consortium/joint venture** must provide consolidated BBBEE certificate

SIGNED BY THE PARTNERS OF THE PARTNERSHIP/CONSORTIUM/JOINT VENTURE

NAME OF FIRM	ADDRESS	DULY AUTHORISED SIGNATORY
Lead partner:		

(12) SUPPLY CHAIN MANAGEMENT AND DECLARATION IN TERMS OF REGULATION 12 OF THE PREFERENTIAL PROCUREMENT REGULATIONS

NOTICE NO.: 101/2025
BID NUMBER: BID/NC062/18/2025-2026

Starting Date: 21/11/2025

Closing Date: 05/12/2025

Closing Time: 12:00 Midday

In terms of SECTION 112(1) of the MUNICIPAL FINANCE MANAGEMENT ACT 2003 (Act No. 56 of 2003) and in terms of CLAUSES 43 and 44 of the MUNICIPAL SUPPLY CHAIN MANAGEMENT POLICY

I, _____, the undersigned, warrants that I am duly authorized to act on behalf of the enterprise mentioned below and do hereby certify that, to the best of my personal knowledge, neither the enterprise nor any of its owners, directors, members or partners has—

- i) failed to pay any municipal rates and taxes or municipal service charges;
- ii) been in arrears with any municipal accounts with any municipality or municipal entity in the Republic of South Africa, for a period longer than 3 (three) months;
- iii) been convicted of fraud or corruption during the past 5 (five) years;
- iv) abused the supply chain management system of the Municipality or has committed any improper conduct in relation to this system;
- v) failed, during the past 5 (five) years, to perform satisfactory on a previous contract with the Municipality or any other organ of state after written notice was given to the enterprise that performance was unsatisfactory;
- vi) wilfully neglected, reneged on or failed to comply with any government, municipal or other public sector contract during the past 5 (five) years;
- vii) been listed with the Register of Tender Defaulters in terms of section 29 of the Prevention and Combating of Corrupt Activities Act 2004 (Act no. 12 of 2004);
- viii) been listed on National Treasury's database as a person or enterprise prohibited from doing business with the public sector;
- ix) any tax matters that is not cleared by the South African Revenue Services;
- x) been in the service of the state for the past 12 (twelve) months or is in the service of the state; or
- xi) been or is an advisor or consultant contracted with the Municipality.

Further to the above I, the undersigned, herewith disclose the particulars of any kinship (parent, brother, sister or child) with a person that is in the service of the state (see MBD 4), or has been in the service of the state in the previous twelve months of any of its owners, directors, members or partners: (Attached information)

- Full Name of that person:
- Identity Number of that person:
- Particulars of Employer:
- Capacity in which that person is in the service of the state
- Income tax Number

I acknowledge that any misrepresentation in respect of this certificate may be regarded as a reason to cancel the listing or bid as accredited prospective provider and any contract arising out of this information supplied.

All the information provided is true and correct.

The signatory to the tender document is duly authorised and documentary proof regarding any tender issue will when required, be submitted to the satisfaction of the municipality.

DULY AUTHORISED TO SIGN ON BEHALF OF:

(insert name of enterprise)

PRINT FULL NAME : _____

SIGNATURE : _____

IDENTITY NUMBER: _____

(13) RESOLUTION BY DIRECTOR/MEMBERS AND OTHER

NOTICE NO.: 101/2025
BID NUMBER: BID/NC062/18/2025-2026

Starting Date 21/11/2025

Closing Date: 05/12/2025

Closing Time: 12:00 Midday

RESOLUTION for completion by Directors (if the bidder is a (Pty) Ltd or Ltd) or Members (if the bidder is a CC or other)

NAME OF BIDDER: _____

Meeting held at _____ (place)

On _____ (date)

RESOLVED THAT:

16.1. The bidder submits a tender to Nama Khoi Municipality in respect of;

TENDER NO: BID/NC062/18/2025-2026 SUPPLY AND DELIVERY OF HOUSE CONNECTION MATERIAL

16.2. Mr./Mrs./Ms. _____, ID No.. _____ in

his/her capacity as _____, is hereby, authorized to sign the tender and any and all other documents and/or correspondence in connection with and relating to the tender, as well as to sign any contract and or all documentation resulting from the award of the tender to the Bidder,

and who will sign as follows: _____ (SPECIMEN SIGNATURE)

No.	Name	Capacity	Signature
1			
2			
3			
4			

Note: The resolution must be signed by all the directors /members of the bidder. Should the space provided above not be sufficient for all directors/members to sign, please attach a separate sheet to this schedule in the same format.

(14) CONFLICT OF INTEREST DECLARATION – GIFTS AND SPONSORSHIPS

19.1. The bidder shall declare whether it has any conflict of interest in the transaction for which the tender is submitted. (Mark the appropriate box with 'X'.)

YES	NO
-----	----

If yes, the bidder is required to set out the particulars in the table below:

19.2. The bidder shall declare whether it has directly or through a representative or intermediary promised, offered or granted:

- (a) any inducement or reward in connection with the award of this contract; or
- (b) any reward, gift, favor or hospitality to any official or any other role player involved in them implementation of the supply chain management policy.

(Mark the appropriate box with 'X'.)

YES	NO
-----	----

If yes, the bidder is required to set out the particulars in the table below:

19.3. Should the bidder be aware of any corrupt or fraudulent transactions relating to the procurement process of Nama Khoi Municipality, please contact or inform the Municipality.

The bidder hereby certifies that the information set out in this schedule and/or attached thereto is true and correct, and acknowledges that failure to properly and truthfully complete this schedule may result in the tender being disqualified, and/or (in the event that the bidder is successful) cancellation of contract.

DULY AUTHORISED TO SIGN ON BEHALF OF:

(insert name of enterprise)

PRINT FULL NAME : _____

SIGNATURE : _____

(15) LIST OF OTHER DOCUMENTATION ATTACHED BY BIDDER

31.1. The bidder has attached to this schedule the following additional documentation

No.	Date of document	Title or description of document
1.		
2.		
3.		
4.		
5.		
6.		
7.		
8.		
9.		
10.		

24.2 Attached additional pages if more space is required.

DULY AUTHORISED TO SIGN ON BEHALF OF:

(insert name of enterprise)

PRINT FULL NAME : _____

SIGNATURE : _____



PART C:

IMPORTANT TENDER INFORMATION

1. Following is a list of the services and specifications that are required:

2. PREREQUISITES

The Municipality has identified a general set of prerequisites for procurement. **Bids will not be considered should the prerequisites not be met.**

- **GENERAL PREREQUISITES** identified by the Municipality:
 - a) Proof of company registration and/or any other form of legal standing must be submitted by all bidders.
 - b) Servicers Providers must be registered on the Central Supplier Database (CSD). Full CSD report must accompany this tender document.
 - c) All Municipal Bidding Documents (MBD) must be completed and signed in full.
 - d) Bids must be submitted on original bid documents.
 - e) Bid documents must remain intact and no portion may be detached.

3. EVALUATION OF TENDERS

- No Functionality Criteria will apply to this tender.
- Tenders will be evaluated based on the 80/20 procurement principle whereby the 80 points will be for price and the other 20 points for specific goals as set out in MBD6.1.

4. PRICING OF THE TENDER

The evaluation of the quotations as received will be based on the 80/20 procurement principle, whereby the 80 points will be for price and the other 20 points for specific goals. Refer to MBD 6.1 for the allocation of points for specific goals. The Service Provider with the highest points scored will be appointed for the specific Tender.

Prices quoted should include delivery cost and all prices must be inclusive of VAT.

The prices quoted must include all other costs involved in the supply and delivery of the goods.

PAYMENT

Payments will be made within thirty (30) days of receipt of the statement or invoice.



PART D

AGREEMENTS AND CONTRACT DATA

1. GENERAL CONDITIONS OF CONTRACT (GCC)

(1) GENERAL CONDITIONS OF CONTRACT (GCC)

adopted from National Treasury

NOTICE NO.: 101/2025
BID NUMBER: BID/NC062/18/2025-2026

Starting Date: 21/11/2025

Closing Date: 05/12/2025

Closing Time: 12:00 Midday

1.1. Definitions

The following terms shall be interpreted as indicated:

- 1.1.1 "Closing time" means the date and hour specified in the bidding documents for the receipt of bids.
- 1.1.2 "Contract" means the written agreement entered into between the purchaser and the supplier, as recorded in the contract from signed by the parties, including all attachments and appendices thereto and all documents incorporated by reference therein.
- 1.1.3 "Contract price" means the price payable to the supplier under the contract for the full and proper performance of this contractual obligation.
- 1.1.4 "Corrupt practice" means the offering, giving, receiving, or soliciting of anything of value to influence the action of a public official in the procurement process or in contract execution.
- 1.1.5 "Countervailing duties" are imposed in cases where an enterprise abroad is subsidized by its government and encouraged to market its products internationally.
- 1.1.6 "Country of origin" means the place where goods were mined, grown or produced or from which the services are supplied. Goods are produced when, through manufacturing, processing or substantial and major assembly of components, a commercially recognized new product results that is substantially different in basis characteristics or in purpose or utility from its components.
- 1.1.7 "Day" means calendar day.
- 1.1.8 "Delivery" means delivery in compliance of the conditions of the contract or order.
- 1.1.9 "Delivery ex stock" means immediate delivery directly from stock actually on hand.
- 1.1.10 "Delivery into consignees store or to his site" means delivered and unloaded in the specified store or depot or on the specified site in compliance with the conditions of the contract or order, the supplier bearing all risks and charges involved until the supplies are so delivered and a valid receipt is obtained.
- 1.1.11 "Dumping" occurs when a private enterprise abroad market its good on own initiative in the RSA at lower prices than that of the country or origin and which have the potential to harm the local industries in the RSA.
- 1.1.12 "Force majeure" means an event beyond the control of the supplier and not involving the supplier's fault or negligence and not foreseeable. Such events may include, but is not restricted to, acts of the purchaser in its sovereign capacity, wars or resolutions, fires floods, epidemics, quarantine restrictions and freight embargoes.
- 1.1.13 "Fraudulent practice" means a misrepresentation of facts in order to influence a procurement process or the execution of a contract to the detriment of any bidder, and includes collusive practice among bidders (prior to or after bid submission) designed to establish bid prices at

artificial non-competitive levels and to deprive the bidder of the benefits of free and open competition.

- 1.1.14 "GCC" mean the General Conditions of Contract.
- 1.1.15 "Good" means all of the equipment, machinery, and/or other materials that the supplier is required to supply to the purchaser under the contract.
- 1.1.16 "Imported content" means that portion of the bidding price represented by the cost of components, parts or materials which have been or are still to be imported (whether by the supplier or his subcontractors) and which costs are inclusive of the costs abroad, plus freight and other direct importation costs such as landing costs, dock dues, import duty, sales duty or other similar tax or duty at the South African place of entry as well transportation and handling charges to the factory in the Republic where the supplies covered by the bid will be manufactured.
- 1.1.17 "Local content" means that portion of the bidding price, which is not included in the imported content provided that local manufacture does take place.
- 1.1.18 "Manufacture" means the production of products in a factory using labour, materials components and machinery and includes other related value-adding activities.
- 1.1.19 "Order" means an official written order issued for the supply of goods or works or the procuring of a service.
- 1.1.20 "Project site" where applicable, means the place indicated in bidding documents.
- 1.1.21 "Purchaser" means the organization purchasing the goods.
- 1.1.22 "Republic" means the Republic of South Africa.
- 1.1.23 "SCC" means the Special Conditions of Contract.
- 1.1.24 "Services" means those functional services ancillary to the supply of the goods, such as transportation and any other incidental services, such as installation, commissioning, provision of technical assistance, training, catering, gardening, security, maintenance and other such obligations of the supplier covered under the contract.
- 1.1.25 "Written" or "in writing" means handwritten in ink or any form of electronic or mechanical writing.

1.2. Application

- 1.2.1 These general conditions are applicable to all bids, contracts and orders including bids for functional and professional services, sales, hiring, letting and the granting or acquiring of rights, but excluding immovable property, unless otherwise indicated in the bidding documents.
- 1.2.2 Where applicable, special conditions of contract are also laid down to cover specific supplies, services or works.
- 1.2.3 Where such special conditions of contract are in conflict with these general conditions, the special shall apply.

1.3. General

- 1.3.1 Unless otherwise indicated in the bidding documents, the purchase shall not be liable for any expense incurred in the preparation and submission of a bid. Where applicable a non-refundable fee for documents may be charged.
- 1.3.2 With certain exceptions, invitations for bid are only published in the Government Tender Bulletin. The Government Tender Bulletin may be obtained directly from the Government Printer, Private Bag X85, Pretoria 0001, or accessed electronically from www.treasury.gov.za.

1.4. Standards

- 1.2.1 The goods supplied shall conform to the standards mentioned in the bidding documents and specifications.

1.5. Use of contracts documents and information

- 1.5.1. The supplier shall not, without the purchaser's prior written consent, disclose the contract, or any provision thereof, or any specification, plan, drawing, pattern, sample or information furnished by or on behalf of the purchaser in connection therewith, to any person other than a person employed by the supplier in the performance of the contract. Disclosure to any such employed person shall be made in confidence and shall extend only as far as may be necessary for purposes of such performance.
- 1.5.2. The supplier shall not, without the purchaser's prior written consent, make use of any document or information mentioned in GCC clause 1.5.1 except for purposes of performing the contract.
- 1.5.3. Any document, other than the contract itself mentioned in GCC clause 1.5.1 shall remain the property of the purchaser and shall be returned (all copies) to the purchaser on completion of the supplier's performance under the contract if so required by the purchaser.
- 1.5.4. The supplier shall permit the purchaser to inspect the supplier's records relating to the performance of the supplier and to have them audited by auditors appointed by the purchaser, if so required by the purchaser.

1.6. Patent rights

- 1.6.1. The supplier shall indemnify the purchaser against all third-party claims of infringement of patent, trademark, or industrial design rights arising from use of the goods or any part thereof by the purchaser.

1.7. Performance Security

- 1.7.1 Within thirty (30) days of receipt of the notification of contract award, the successful bidder shall furnish to the purchaser the performance security of the amount specified in GCC.
- 1.7.2 The proceeds of the performance security shall be payable to the purchaser as compensation for any loss resulting from the supplier's failure to complete his obligations under the contracts.
- 1.7.3 The performance security shall be denominated in the currency of the contract, or in freely convertible currency acceptable to the purchaser and shall be in one of the following:
 - (a) a bank guarantee or an irrevocable letter of credit issued by a reputable bank located in the purchaser's country or broad, acceptable to the purchaser, in the form provided in the bidding documents or another form acceptable to the purchaser; or

- (b) a cashier's or certified cheque
- 1.7.4 The performance security will be discharged by the purchaser and returned to the supplier not later than thirty (30) days following the date of completion of the supplier's performance obligations under the contract, including any warranty obligations, unless otherwise specified in SCC.

1.8. Inspections, tests and analyses

- 1.8.1 All pre-bidding testing will be for the account of the bidder.
- 1.8.2 If it is a bid condition that supplies to be produced or services to be procured should at any stage during production or execution or on completion be subject to inspection, the premises of the bidder or contractor shall be open, at all reasonable hours, for inspection by a representative of the Department or an organization acting on behalf of the Department.
- 1.8.3 If there are no inspection requirements indicated in the bidding documents and no mention is made in the contract, but during the contract period it is decided that inspections shall be carried out, the purchaser shall itself make the necessary arrangements, including payments arrangements with the testing authority concerned.
- 1.8.4 If the inspection, test and analyses referred to in clauses 1.8.2 and 1.8.3 show the supplies to be in accordance with the contract requirements, the cost of the inspections, tests and analyses shall be defrayed by the purchaser.
- 1.8.5 Where the supplies or services referred to in clauses 1.8.2 and 1.8.3 do not comply with the contract requirements, irrespective of whether such supplies or services are accepted or not, the cost in connection with these inspections, tests or analyses shall be defrayed by the supplier.
- 1.8.6 Supplies and services, which are, referred to in clauses 1.8.2 and 1.8.3 and which do not comply with the contract requirements may be rejected.
- 1.8.7 Any contract supplies may, on or after delivery, be inspected; tested or analyzed and may be rejected if found no to comply with the requirements of the contract. Such rejected supplies shall be held at the cost and risk of the supplier who shall, when called upon, remove them immediately at his own cost and forthwith substitute them with supplies which do comply with the requirements of the contract. Failing such removal the rejected supplies shall be returned at the suppliers cost and risk. Should the supplier fail to provide the substitute supplies forthwith, the purchase may without giving the supplier further opportunity to substitute the rejected supplies purchase such supplies as may be necessary at the expense of the supplier.
- 1.8.8 The provisions of clauses 1.8.4 to 1.8.7 shall not prejudice the right of the purchaser to cancel the contract on account of a breach of the conditions thereof, or to act in terms of Clause 1.23 of GCC.

1.9. Packing

- 1.9.1 The supplier shall provide such packing of the goods as is required to prevent their damage or deterioration during transit to their final destination, as indicated in the contract. The packing shall be sufficient to withstand, without limitation, rough handling during transit and exposure to extreme temperatures, salt and precipitations during transit, and open storage. Packing, case size and weights shall take into consideration, where appropriate, the remoteness of the goods' final destination and the absence of heavy handling facilities at all points in transit.
- 1.9.2
- 1.9.3 The packing, marking and documentation within and outside the packages shall comply strictly with such special requirements as shall be expressly provided for in the contract, including additional requirements, if any, specified in SCC, and in any subsequent instructions ordered by

the purchaser.

1.10. Delivery and documents

1.10.1 Delivery of the goods shall be made by the supplier in accordance with the terms specified in the contract. The details of shipping and/or other documents to be furnished by the supplier are specified in SCC.

1.11. Insurance

1.11.1 The goods supplied under the contract shall be fully insured in a freely convertible currency against loss or damage incidental to manufacture or acquisition, transportation, storage and delivery in the manner specified in the SCC.

1.12. Transportation

1.12.1 Should a price other than an all inclusive delivered price be required, this shall be specified in the SCC.

1.13. Incidental services

1.13.1 The supplier may be required to provide any or all of the following services, including additional services, if any specified in SCC:

- (a) performance or supervision of on-site assembly and/or commissioning of the supplied goods;
- (b) furnishing of tools required for assembly and/or maintenance of the supplied goods;
- (c) furnishing of a detailed operations and maintenance manual for each appropriate unit of the supplied goods;
- (d) performance or supervision or maintenance and/or repair of the supplied goods, for a period of time agreed by the parties, provided that this service shall not relieve the supplier of any warranty obligations under this contract; and
- (e) training of the purchaser's personnel, at the supplier's plant and/or on-site, in assembly, start-up, operation, maintenance, and/or repair of the supplied goods.

1.13.2 Prices charged by the supplier for incidental services, if not included in the contract price for the goods, shall be agreed upon in advance by the parties and shall not exceed the prevailing rates charged to other parties by the supplier for similar services.

1.14. Spare parts

1.14.1 As specified in SCC, the supplier may be required to provide any or all of the following materials, notifications, and information pertaining to spare parts manufactured or distributed by the supplier:

- (a) such spare parts as the purchaser may elect to purchase from the supplier, provided that this election shall not relieve the supplier of any warranty obligations under the contract; and
- (b) in the event of termination of production of the spare parts:
 - (i) Advance notification to the purchaser of the pending termination, in sufficient time to permit the purchaser to procure needed requirements; and
 - (ii) Following such termination, furnishing at no cost to the purchaser, the blueprints, drawings and specifications of the spare parts, if requested.

1.15. Warranty

- 1.15.1 The supplier warrants that the goods supplied under the contract are new, unused, of the most recent or current models and that they incorporate all recent improvements in design and materials unless provided otherwise in the contract. The supplier further warrants that all goods supplied under this contract shall have no defect, arising from design, materials, or workmanship (except when the design and/or material is required by the purchaser's specifications) or from any act or omission of the supplier, that may develop under normal use of the supplied goods in the conditions prevailing in the country of final destination.
- 1.15.2 The purchaser shall promptly notify the supplier in writing of any claims arising under this warranty.
- 1.15.3 Upon receipt of such notice, the supplier shall, with the period specified in SCC and with all reasonable speed, repair or replace the defective goods or parts thereof, without costs to be purchaser.
- 1.15.4 If the supplier, having been notified, fails to remedy the defect(s) within the period specified in SCC, the purchaser may proceed to take such remedial action as may be necessary, at the supplier's risk and expense and without prejudice to any other rights which the purchaser may have against the supplier under the contract.

1.16. Payment

- 1.16.1 The method and conditions of payment to be made to the supplier under this contract shall be specified in SCC.
- 1.16.2 The supplier shall furnish the purchaser with an invoice accompanied by a copy of the delivery note and upon fulfillment of other obligations stipulated in the contract.
- 1.16.3 Payments shall be made promptly by the purchaser, but in no case later than thirty (30) days after submission of an invoice or claim by the supplier.
- 1.16.4 Payment will be made in Rand unless otherwise stipulated in SCC.

1.17. Prices

- 1.17.1 Prices charged by the supplier for goods delivered and services performed under the contract shall not vary from the prices quoted by the supplier in his bid, with the exception of any price adjustments authorized in SCC or in the purchaser's request for bid validity extension, as the case may be.

1.18. Contract Amendments

- 1.18.1 No variation in or modification of the terms of the contract shall be made except by written amendment signed by the parties concerned.

1.19. Assignment

- 1.19.1 The supplier shall not assign, in whole or in part, its obligations to perform under the contract, except with the purchaser's prior written consent.

1.20. Subcontracts

- 1.20.1 The supplier shall notify the purchaser in writing of all subcontracts awarded under this contract if not already specified in the bid. Such notification, in the original bid or later, shall not relieve the supplier from any liability or obligation under the contract.

1.21. Delays in the supplier's performance

- 1.21.1 Delivery of the goods and performance of services shall be made by the supplier in accordance with the time schedule prescribed by the purchaser in the contract.
- 1.21.2 If at any time during performance of the contract, the supplier or its subcontractor(s) should encounter conditions impeding timely delivery of the goods and performance of services, the supplier shall promptly notify the purchaser in writing of the fact of the delay, its likely duration and its cause(s). As soon as practicable after receipt of the supplier's notice, the purchaser shall evaluate the situation and may at his discretion extend the supplier's time for performance, with or without the imposition of penalties, in which case the extension shall be ratified by the parties by amendment of contract.
- 1.21.3 No provision in a contract shall be deemed to prohibit the obtaining of supplies or services from a national department, provincial department, or local authority.
- 1.21.4 The right is reserved to procure outside of the contract small quantities or to have minor essential services executed if an emergency arises, the supplier's point of supply is not situated at or near the place where the supplies are required, or the supplier's services are not readily available.
- 1.21.5 Except as provided under GCC clause 1.25, a delay by the supplier in the performance of its delivery obligations shall procure the supplier liable to the imposition of penalties, pursuant to GCC clause 1.22, unless an extension of time is agreed upon pursuant to GCC clause 1.21.2 without the application of penalties.
- 1.21.6 Upon any delay beyond the delivery period in the case of a supplies contract, the purchaser shall, without cancelling the contract, be entitled to purchase supplies of a similar quality and up to the same quantity in substitution of the goods not supplied in conformity with the contract and to return any goods delivered later at the supplier's expense and risk, or to cancel the contract and buy such goods as may be required to complete the contract and without prejudice to his other rights, be entitled to claim damages from the supplier.

1.22. Penalties

- 1.22.1 Subject to GCC clause 1.25, if the supplier fails to deliver any or all of the goods or to perform the services within the period(s) specified in the contract, the purchaser shall, without prejudice to its other remedies under the contract, deduct from the contract price, as a penalty, a sum calculated on the delivered price of the delayed goods or unperformed services using the current prime interest rate calculated for each day of the delay until actual delivery or performance. The purchaser may also consider termination of the contract pursuant to GCC clause 1.23.

1.23. Termination for default

1.23.1 The purchaser, without prejudice to any other remedy for breach of contract, by written notice of default sent to the supplier, may terminate this contract in whole or in part:

- (a) if the supplier fails to deliver any or all of the goods within the period(s) specified in the contract, or within any extension thereof granted by the purchaser pursuant to GCC clause 1.21.2;
- (b) if the supplier fails to perform any other obligation(s) under the contract; or if the supplier, in the judgment of the purchaser, has engaged in corrupt or fraudulent practices in competing for or in executing the contract.

1.23.2 In the event the purchaser terminates the contract in whole or in part, the purchaser may procure, upon such terms and in such manner as it deems appropriate, goods, works or services similar to those undelivered, and the supplier shall be liable to the purchaser for any excess costs for such similar goods, works or services. However, the supplier shall continue performance of the contract to the extent not terminate.

1.24. Anti-dumping and countervailing duties and rights

1.24.1 When, after the date of bid, provisional payments are required, or anti-dumping or countervailing duties are imposed, or the amount of a provisional payment or anti-dumping or countervailing right is increased in respect of any dumped or subsidized import, the State is not liable for any amount so required of imposed, or for the amount of any such increase. When, after the said date, such a provisional payment is no longer required or any such anti-dumping or countervailing right is abolished, or where the amount of such provisional payment or any such right is reduced, any such favorable difference shall on demand be paid forthwith by the contractor to the State may deduct such amounts from moneys (if any) which may otherwise be due to the contractor in regard to supplies or services which he delivered or procured, or is to deliver or procure in terms of the contract or any other contract or any other amount which may be due to him.

1.25. Force Majeure

1.25.1 Notwithstanding the provisions of GCC clauses 1.22 and 1.23, the supplier shall not be liable for forfeiture or its performance security, damages or termination for default if and to the extent that his delay in performance or other failure to perform his obligations under the contract is the result of an event of force majeure.

1.25.2 If a force majeure situation arises, the supplier shall promptly notify the purchaser in writing of such condition and the cause thereof. Unless otherwise directed by purchaser in writing, the supplier shall continue to perform its obligations under the contract as far as is reasonably practical, and shall seek all reasonable alternative means for performance not prevented by the force majeure event.

1.26. Termination for insolvency

1.26.1 The purchaser may at any time terminate the contract by giving written notice to the supplier if the supplier becomes bankrupt or otherwise insolvent. In this event, termination will be without compensation to the supplier, provided that such termination will prejudice or affect any right of action or remedy, which has accrued or will accrue thereafter to the purchaser.

1.27. Settlement of Disputes

- 1.27.1 If any dispute or difference of any kind whatsoever arises between the purchaser and the supplier in connection with or arising out of the contract, the parties shall make every effort to resolve amicably such dispute or difference by mutual consultation.
- 1.27.2 If, after thirty (30) days, the parties have failed to resolve their dispute or difference by mutual consultation, then either the purchaser or the supplier may give notice to the other party of his intention to commence with mediation. No mediation in respect of this matter may be commenced unless such notice is given to the other party.
- 1.27.3 Should it not be possible to settle a dispute by means of mediation, it may be settled in a South African court of law.
- 1.27.4 Mediation proceedings shall be conducted in accordance with the rules or procedure specified in the SCC.
- 1.27.5 Notwithstanding any reference to mediation and/or court proceedings herein,
- (a) the parties shall continue to perform their respective obligations under the contract unless they otherwise agree; and
 - (b) the purchaser shall pay the supplier any monies due the supplier.

1.28. Limitation of liability

- 1.28.1 Except in cases of criminal negligence or willful misconduct, and in the case of infringement pursuant to clause 1.6;
- (a) the supplier shall not be liable to the purchaser, whether in contract, tort, or otherwise, for any indirect or consequential loss or damage, loss or use, loss of production, or loss of profits or interest costs, provided that this exclusion shall not apply to any obligation of the supplier to pay penalties and/or damages to the purchaser; and
 - (b) the aggregate liability of the supplier to the purchaser, whether under the contract, in tort or otherwise, shall not exceed the total contract price, provided that this limitation shall not apply to the cost of repairing or replacing defective equipment.

1.29. Governing language

- 1.29.1 The contract shall be written in English. All correspondence and other documents pertaining to the contract that is exchanged by the parties shall also be written in English.

1.30. Applicable law

- 1.30.1 The contract shall be interpreted in accordance with South African laws, unless otherwise specified in SCC.

1.31. Notices

- 1.31.1 Every written acceptance of a bid shall be posted to the supplier concerned by registered or certified mail and any other notice to him shall be posted by ordinary mail to the address furnished in his bid or to the address notified later by him in writing and such posting shall be deemed to be proper service of such notice.
- 1.31.2 The time mentioned in the contract documents for performing any act after such aforesaid notice has been given, shall be reckoned from the date of posting of such notice

1.32. Taxes and duties

- 1.32.1 A foreign supplier shall be entirely responsible for all taxes, stamp duties, license fees, and other such levies imposed outside the purchaser's country.
 - 1.32.2 A local supplier shall be entirely responsible for all taxes, duties, license fees, etc., incurred until delivery of the contracted goods to the purchaser.
 - 1.32.3 No contract shall be concluded with any bidder whose tax matters are not in order. Prior to the award of a bid the Department must be in possession of a tax clearance certificate, submitted by the bidder. This certificate must be an original issued by the South African Revenue Services.
-



PART E:

PRICING DATA

1. PRICING INSTRUCTIONS

NOTICE NO.: 101/2025
BID NUMBER: BID/NC062/18/2025-2026

Starting Date: 21/11/2025

Closing Date: 05/12/2025

Closing Time: 12:00 Midday

1.1. General and rates

- 1.1.1. All the prices shall be tendered including all applicable taxes..
- 1.1.2. All prices Tendered must include all expenses, disbursements and costs (transport, overheads etc.) that may be incurred in the execution of this contract and shall cover all the general risks, liabilities and obligations set implicitly in the contract.
- 1.1.3. All prices shall be fixed for the once-off contract and will be final and binding. The bidder must include all costs in the pricing schedule; additional charges after tender submission will not be accepted.

1.2. Corrections made

- 1.2.1. Any entry made by the bidder in the price schedule, which the bidder desires to change, shall not be erased or printed out.
- 1.2.2. A line shall then be drawn through the incorrect entry and the correct entry shall be written above in black ink and the full signature of the bidder shall be placed next to the correction.

2. PRICING SCHEDULE – BILL OF QUANTITIES

NOTICE NO.: 101/2025
BID NUMBER: BID/NC062/18/2025-2026

Starting Date: 21/11/2025

Closing Date: 05/12/2025

Closing Time: 12:00 Midday

NAMA KHOI LOCAL MUNICIPALITY
ELECTRIFICATION OF 31 HOUSES - PROVISION OF MATERIALS
SCHEDULE A : 400 V LOW VOLTAGE RETICULATION NETWORK

Rev 01

Item no.	Description	Unit	Qty	Supply Rate	Amount
1	<u>LOW VOLTAGE NETWORK</u>				
1,1	- <u>Eucalyptus Wooden Poles</u> Supply, delivery and installation of Class A poles:				
a)	9 m long (140 mm min pole top diameter)	No.	6		
1,2	<u>Stays</u> Supply, delivery and installation of stays complete with stay wire, stay rod and base plate, insulator and termination kit:				
a)	Adjustable stay with (M12 x 1500 mm long) as per Eskom D-D-T 0341 5-1-17	No.	6		
b)	LV and MV Reticulation Strut Assembly as per Eskom D-D-T 0342 1-1-3	No.	2		
1,3	<u>600/ 1000 V Aerial Bundle Conductor to SANS</u> Supply, delivery and installation of the Aerial Bundled Conductor manufactured to SANS 1418 1 & 2. Rates shall include binding and tensioning for:				
1,3,1	70 mm ² x 3 + 54,6 mm ² + 25 mm ²	m	100		
1,4	<u>Clamps for Aerial Bundled Conductor</u> Supply, delivery and installation clamps complete with all bolts, nuts, washers and pigtails:				
(a)	0-30 deg deviation, Eskom D-DT 1100 1-1-4	No	9		
(b)	0-60 deg deviation, Eskom D- DT 1121 1-1-5	No	5		
(c)	60-90 deg deviation, Eskom D- DT 1122 1-1-5	No	4		
(d)	ABC Terminal Assembly, Eskom D-DT 1120 1-1-5	No	5		
1,5	Drilling of Holes for				
1,5,1	9 m Wooden Poles, 1,8 m deep	No	6		
1,5,2	Adjustable Stays, 1,8 m deep	No	6		
	-				
TOTAL FOR LOW VOLTAGE RETICULATION NETWORK					

ELECTRIFICATION OF 31 HOUSES - PROVISION OF MATERIALS

SCHEDULE B : CONSUMER CONNECTION

Item no.	Description	Unit	Qty	Supply Rate	Amount
2	<u>CONSUMER CONNECTIONS</u>				
2,1	-				
(a)	<u>600V/1000V Concentric Cable (Airdac)</u> Supply, delivery and installation of concentric cable: 10 mm ² Airdac CNE, SANS 1507-6	m	500		
2,2	<u>Airdac strain clamps, Sicame PP63R17 for Concentric Cable</u> Supply, delivery and installation of clamps complete with all accessories for installation:				
(a)	LV Service connection, Eskom D DT 0360 5-1-14	No.	31		
(b)	Additional strain clamps for relocation of Airdac Connections	No.	15		
2,3	<u>PLC, Split- Unit Prepaid Metering</u> Supply, delivery and installation of prepaid kWh consumer meters including all accessories, token cards for installation and programming as specified: Single phase consumer energy meter + key pad & Common base plate similar or equal approved to the Landys + Gyr E460S with display and onboard keypad + CIU split unit meter	No	31		
2,4	<u>Pole Mounted Split-Unit Pre Paid meter and Circuit Breaker Boxes</u> Supply, delivery and installation of pole mounted split unit and circuit breaker boxes similar and equally specified to attached Eskom Specification to house meter specified in 4,3				
a)	8 Way as per specifications and drawings	No.	31		
2,5	<u>Circuit Breaker (5kA) for Pole Mounted Boxes</u> Supply, delivery and installation of pole mounted circuit breaker boxes as specified.				
a)	40 A, 6 kA, Curve 1 (Orange Toggle) Single Pole Circuit breaker	No.	31	-----	
2,6	<u>Testing and Commissioning</u> Testing and commissioning of consumer installations installation including, prepaid meters and the issuing of a Certificate of Compliance for each installation.	Each	31	-----	
2,7	<u>Miscellaneous Material</u> Allow small materials eg. ferrules, lugs, insulation tape termination boxes glands etc. for the completion of consumer connections.	P.C	1	2 500,00	
TOTAL FOR CONSUMER CONNECTIONS					

ELECTRIFICATION OF 31 HOUSES - PROVISION OF MATERIALS

SCHEDULE C : SUMMARY

Item no.	Description	Amount
3,1	<u>SCHEDULE A : 400 V LOW VOLTAGE RETICULATION NETWORK</u>	
3,2	- <u>SCHEDULE B : CONSUMER CONNECTION</u>	
	SUB TOTAL	
4	<u>PLUS VAT 15%</u> TOTAL	

NOTES TO BIDDERS:

- All items quoted must conform to the technical specifications outlined in the Scope of Work.
- Quantities are estimated and may be adjusted by the municipality as required.
- Bidders must ensure that unit prices include all costs, including delivery to the designated location(s).
- Incomplete pricing or failure to submit this schedule will result in the bidder being non-compliant.
- Alternative or equivalent products (if offered) must be clearly indicated and supported by technical documentation. (Refer to 5. Compatibility – page 61)

2. PRICING SCHEDULE – BILL OF QUANTITIES

NOTICE NO.: 101/2025
BID NUMBER: BID/NC062/18/2025-2026

Starting Date: 21/11/2025

Closing Date: 05/12/2025

Closing Time: 12:00 midday

TOTAL AMOUNT (INCLUDING TAXES)	
--------------------------------	--

I, the undersigned, hereby confirm that I am duly authorized to act on behalf of the enterprise. I further declare that the contents of this schedule are, to the best of my personal knowledge and belief, true and correct. I also confirm that this bid has been prepared independently and without any form of collusion with other bidders.

Person authorized to sign Quotation:

FULL NAME: _____

SIGNATURE: _____

DATE: _____



PART F:

SPECIFICATIONS / SCOPE OF WORK

1. SPECIFICATIONS / SCOPE OF WORK

NOTICE NO.: 101/2025

BID NUMBER: BID/NC062/18/2025-2026

Starting Date: 21/11/2025

Closing Date: 05/12/2025

Closing Time: 12:00 Midday

SUPPLY AND DELIVERY OF LED STREET LIGHTS

1. INTRODUCTION

Nama Khoi Local Municipality hereby invites service providers to submit tenders for the supply and delivery of House Connection Material. This tender forms part of the municipality's ongoing commitment to improving public infrastructure and promoting sustainable development and provide basic electrical services.

The project aims to connect 31 BNG houses that was constructed in Okiep but not connected to the Municipal Network.

2. SCOPE OF WORK

The scope of this tender covers the supply and delivery of House connection material for overhead reticulation networks and house connection materials

3. DELIVERY LOCATION

All items should be delivered at the following location:

Nama Khoi Municipal Warehouse, Inry Street, Springbok Industrial Area, 8240

4. TECHNICAL SPECIFICATIONS

The successful bidder shall supply the items as specified in the Bill of Quantities to the specifications of the accompanying Eskom D-DT drawings.

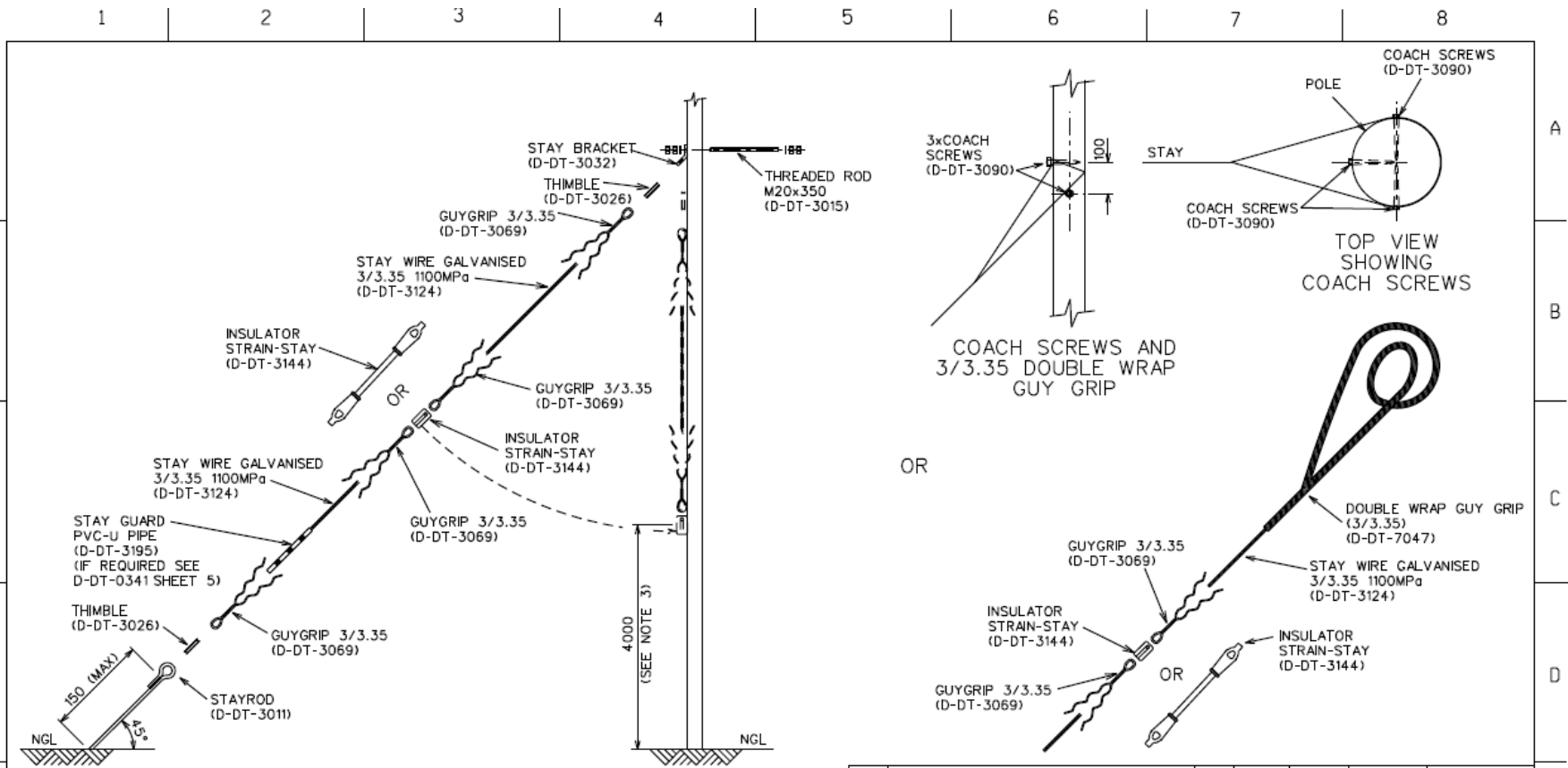

STAY ROD ASSEMBLY (D-DT-0350) OR ROCK ANCHOR INSTALLATION (D-DT-0357) STAYING ATTACHMENT (D-DT-0312)

- NOTE:-
1. READ IN CONJUNCTION WITH STAY ATTACHING METHOD DRG. NO. (D-DT-0166) FOR CONCRETE POLES.
 2. STAY TO BE POSITIONED AS CLOSE TO CROSSARM OR EQUIPMENT AS POSSIBLE.
 3. MINIMUM DIMENSION FROM BOTTOM OF THE INSULATOR TO GROUND TO BE 4000MM WHERE THERE IS NO EQUIPMENT ON THE POLE. IF THERE IS EQUIPMENT ON THE POLE THE INSULATOR IS TO HANG BELOW THE EQUIPMENT WITH A MINIMUM DISTANCE OF 3000MM FROM THE BOTTOM OF THE INSULATOR TO THE GROUND.
 4. FOR ANTI-CLIMBING DEVICE SEE D-DT-0399.
 5. STAY GRIP (D-DT-3195) TO BE POSITIONED ABOVE GUYGRIP, FOR APPLICATION SEE D-DT-0341 SH. 5 (IF REQUIRED).

(INFORMATION TAKEN FROM D-DT-0165 AND D-DT-1165)

REV	REVISION DESCRIPTION	BY	CHKD	AUTH	DATE	PROJECT NO.
17	REFERENCE TO MV/HV STAYROD DRAWING NO. CORRECTED	P.A.T.	B.HILL	B.HILL	05.08.2013	
16	PVC-U STAY GUARD PIPE RUBBER FERRULES REMOVED AND REPLACED WITH UV RESISTANT RUBBER END CAPS	P.A.T.	B.HILL	V.SINGH	03.03.2011	
15	STAY BRKT REPLACED WITH DBL WRAP GUY GRIP SH.4 AND STAY GUARD HDPE PIPE CHANGED TO PVC-U PIPE	P.A.T.	C.VD MERWE	B.HILL	06/10/2010	

		<p>STAY ASSEMBLY (LV - 35kN) WOOD/CONCRETE POLES</p>		
AUTH: B. BRANFIELD	DATE: 11/01/1999	<p>D-DT-0341</p>		
CHKD: B. BRANFIELD	DATE: 11/01/1999			
DRAWN: P. VERMAAK	DATE: 15/10/1998			
		5	1	17

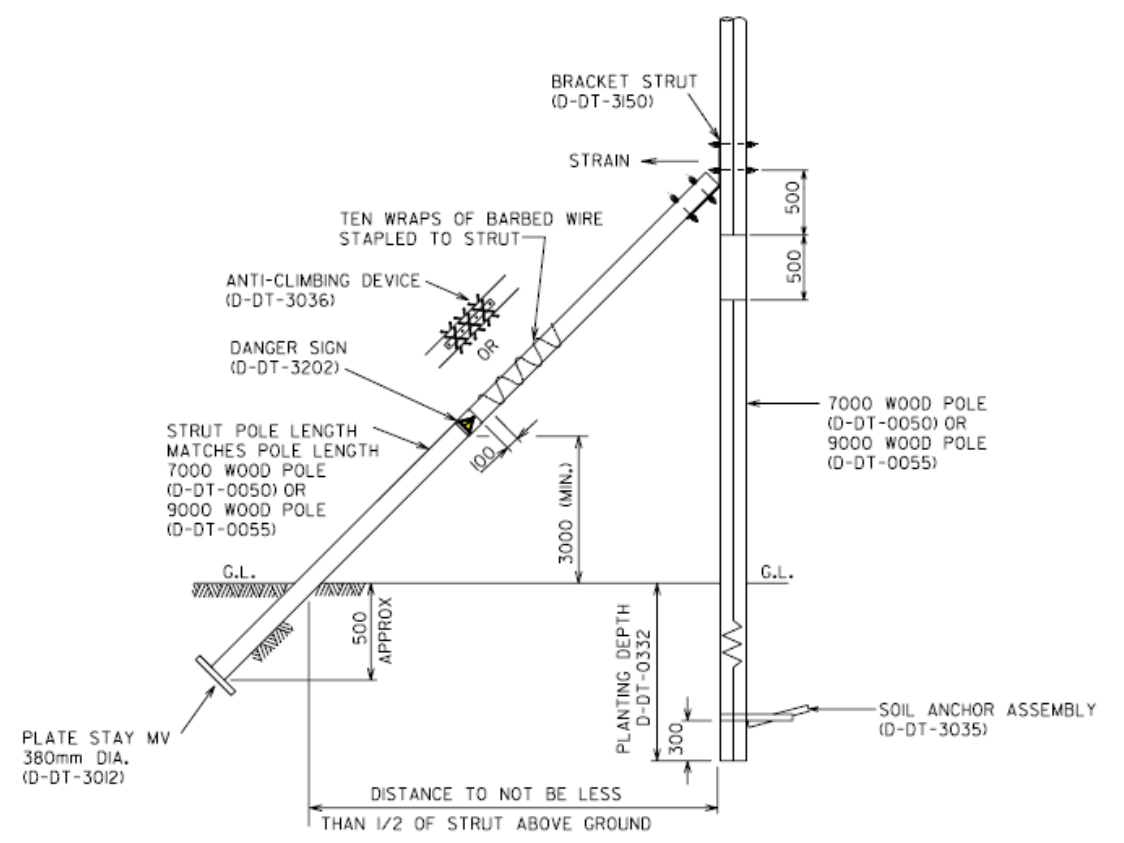

- NOTES:-
1. ALL WOOD CUT OR DRILLED ON SITE TO BE TREATED WITH CREOSOTE.
 2. STRUTS ARE NOT A RECOMMENDED SOLUTION AND SHOULD BE INSTALLED ONLY AS LAST RESORT.
 3. COMPACTION OF POLE SEE SPEC.DTC 0106
 4. FOR INSULATION COORDINATION SEE D-DT-0310.

3	SWIVEL STRUT BRACKET REMOVED AND REFERENCE TO LV ADDED TO TITLE BLOCK	P.A.V.	B.HILL	B.HILL	17.08.2004	
2	STRUT BRACKET CHANGED TO SWIVEL STRUT BRACKET D-DT-3150	P.A.V.	B.HILL	B.HILL	27.01.2004	
1	REFERENCE TO MV REMOVED FROM TITLE BLOCK, INSULATION SHOWN AND DANGER SIGN ADDED	P.A.V.	B.HILL	B.HILL	01.08.2003	
REV	REVISION DESCRIPTION	BY	CHKD	AUTH	DATE	PROJECT NO.

Eskom Distribution

AUTH: B.BRANFIELD

DATE: 11/01/1999

CHKD: B.BRANFIELD

DATE: 11/01/1999

DRAWN: P.A.VERMAAK

DATE: 14/19/1998

LV & MV RETICULATION
STRUT ASSEMBLY
FLAT 45 DEG. BRACKET
7m AND 9m POLES

D-DT-0342	SET	SHEET	REVISION
	1	1	3

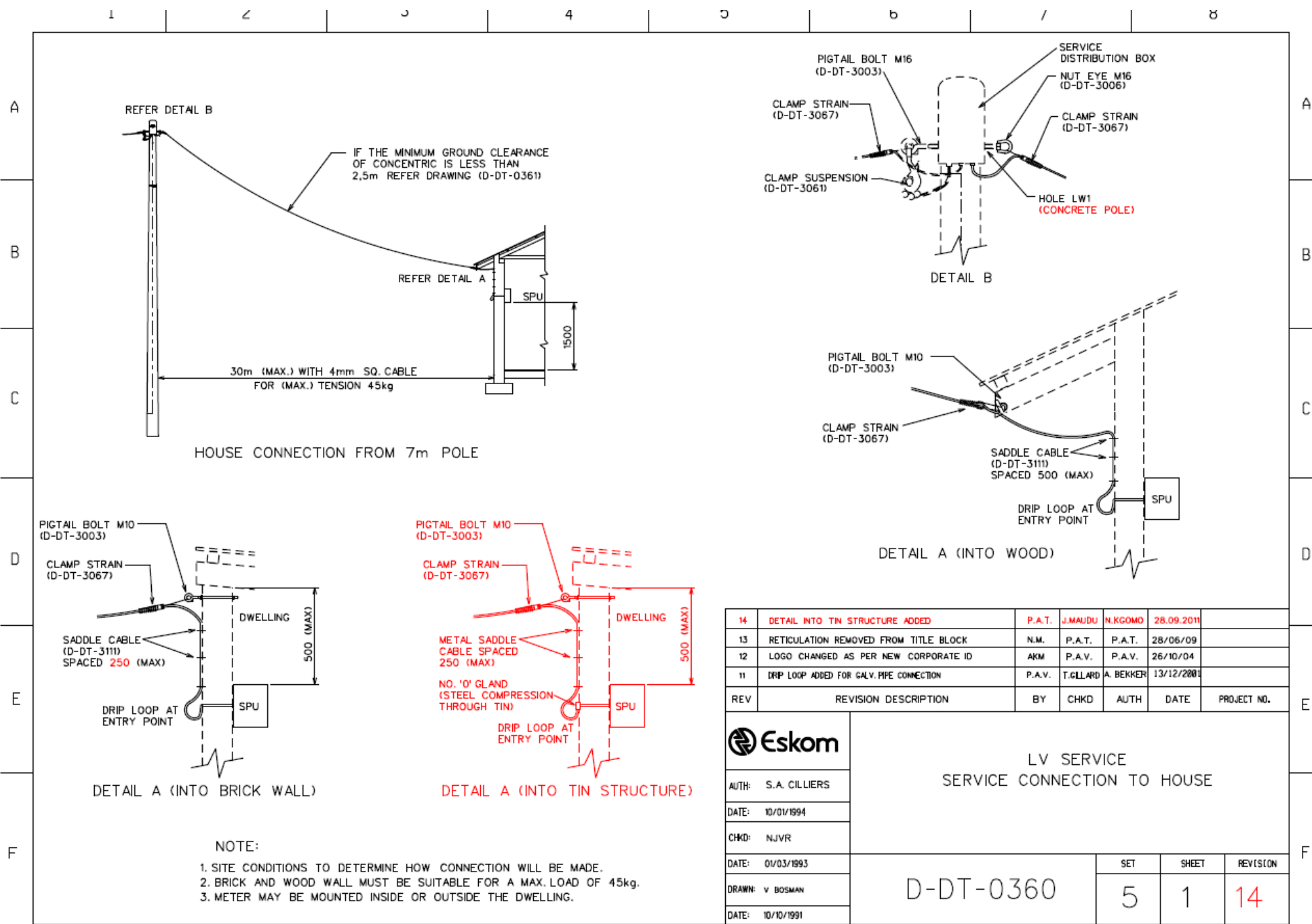

14	DETAIL INTO TIN STRUCTURE ADDED	P.A.T.	J.MAUDU	N.KGOMO	28.09.2011	
13	RETICULATION REMOVED FROM TITLE BLOCK	N.M.	P.A.T.	P.A.T.	28/06/09	
12	LOGO CHANGED AS PER NEW CORPORATE ID	AKM	P.A.V.	P.A.V.	26/10/04	
11	DRIP LOOP ADDED FOR GALV. PIPE CONNECTION	P.A.V.	T.GILLARD	A. BEKKER	13/12/2001	
REV	REVISION DESCRIPTION	BY	CHKD	AUTH	DATE	PROJECT NO.

		LV SERVICE SERVICE CONNECTION TO HOUSE							
						AUTH: S.A. CILLIERS			
						DATE: 10/01/1994			
						CHKD: NJVR			
DATE: 01/03/1993		D-DT-0360		SET	SHEET	REVISION			
DRAWN: v BOSMAN				5	1	14			
DATE: 10/10/1991									

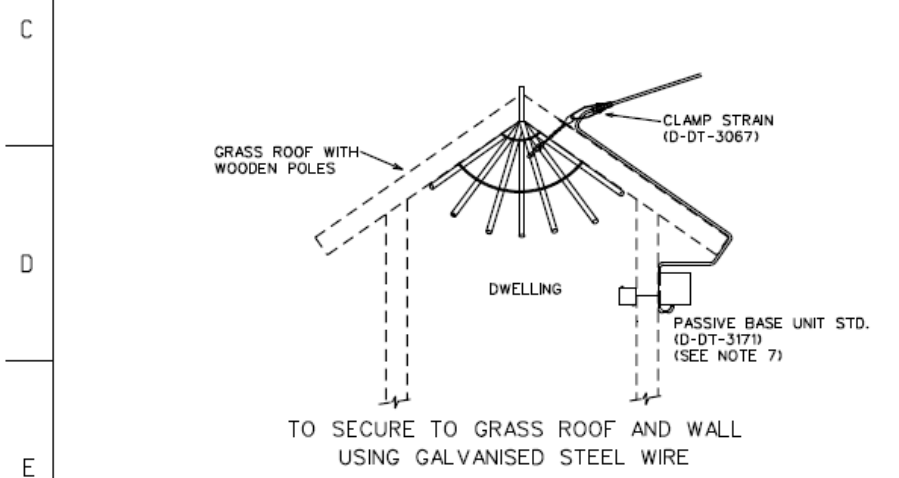
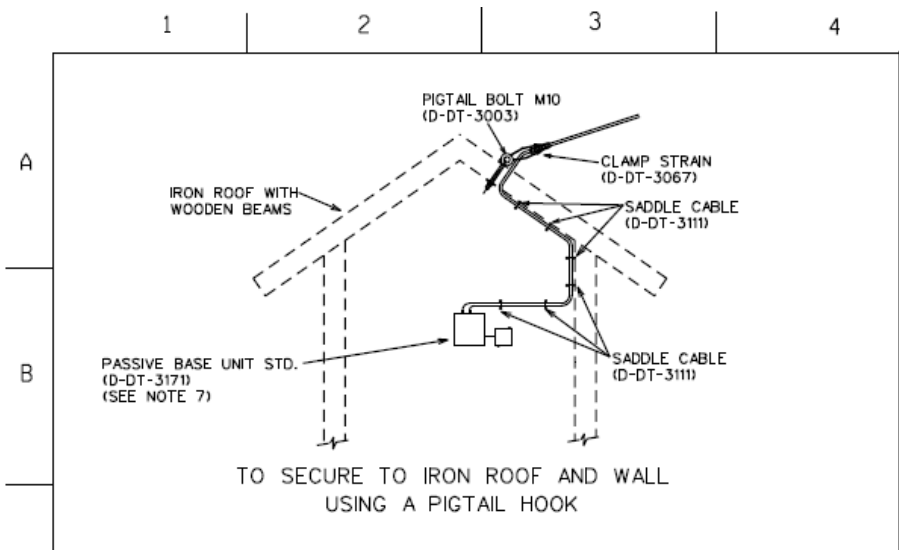

- NOTE:
1. PRIOR APPROVAL NEEDS TO BE OBTAINED FROM THE LOCAL ESKOM ENGINEERING DEPARTMENT BEFORE THIS METHOD IS APPLIED IN EACH REGION.
 2. ATTACH TO THE ROOF THEREBY ELIMINATING THE USE OF A SERVICE POLE.
 3. ROOF STRUCTURE MUST BE SUITABLE FOR MAXIMUM SPAN TENSION.
 4. SILICONE SEALANT **UV STABLE**, SHALL BE APPLIED AT THE ENTRY POINT ON THE ROOF TO PREVENT WATER INGRESS INTO THE PREMISES.
 5. NO SECONDARY DAMAGE SHALL OCCUR TO THE PREMISES.
 6. METER MAY BE MOUNTED INSIDE OR OUTSIDE THE DWELLING.

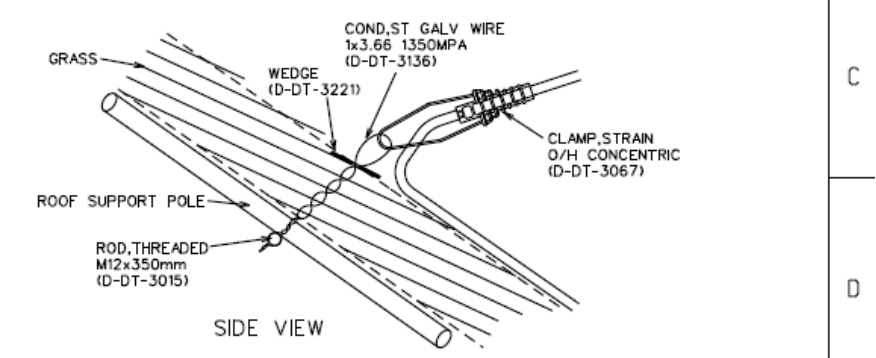
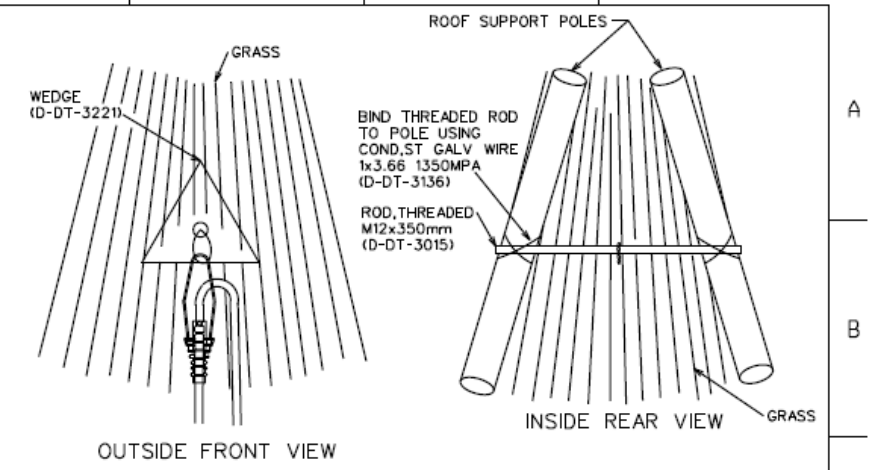

REV	REVISION DESCRIPTION	BY	CHKD	AUTH	DATE	PROJECT NO.
14	DETAIL INTO TIN STRUCTURE ADDED	P.A.T.	J.MAUBU	N.KGOMO	28.09.2011	
13	RETICULATION REMOVED FROM TITLE BLOCK	N.M.	P.A.T.	P.A.T.	28/06/09	
12	LOGO CHANGED AS PER NEW CORPORATE ID	AKM	P.A.V.	P.A.V.	26/10/04	
11	DRIP LOOP ADDED FOR GALV. PIPE CONNECTION	P.A.V.	T.GILLARD	A.BEKKER	13/12/2001	

	LV SERVICE SERVICE CONNECTION TO HOUSE				
	AUTH: S.A. CILLIERS	D-DT-0360	SET	SHEET	REVISION
	DATE: 10/01/1994		5	2	14
	CHKD: N.JVR	DATE: 01/03/1993			
DRAWN: V BOSMAN	DATE: 10/10/1991				

1 2 3 4 5 6 7 8

A
B
C
D
E
F

A
B
C
D
E
F

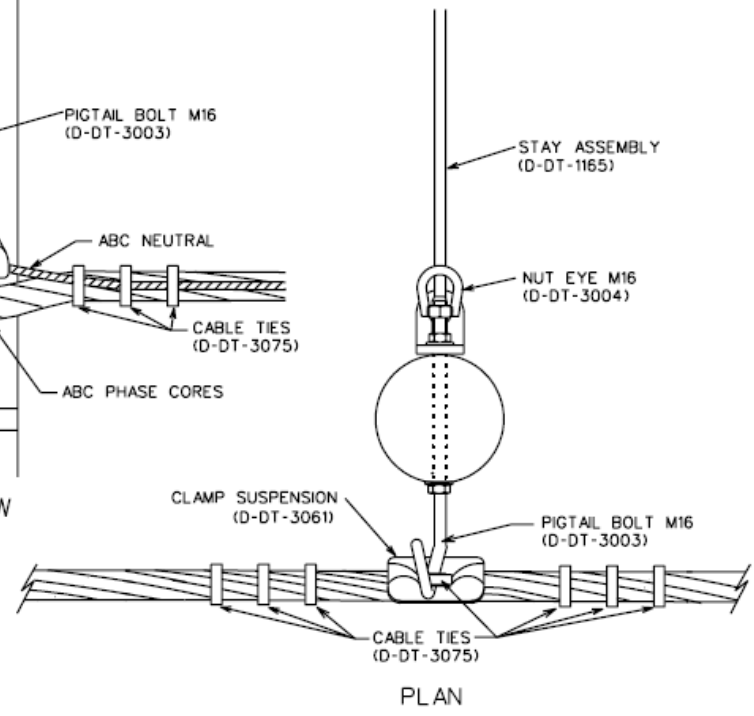
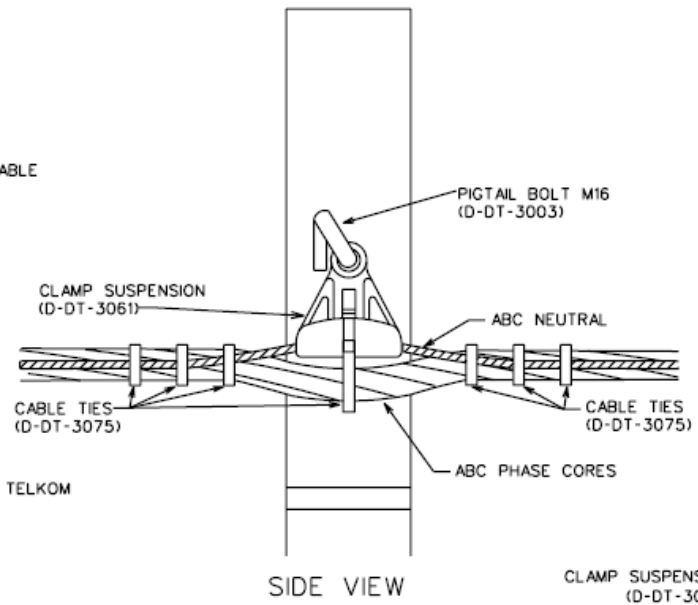
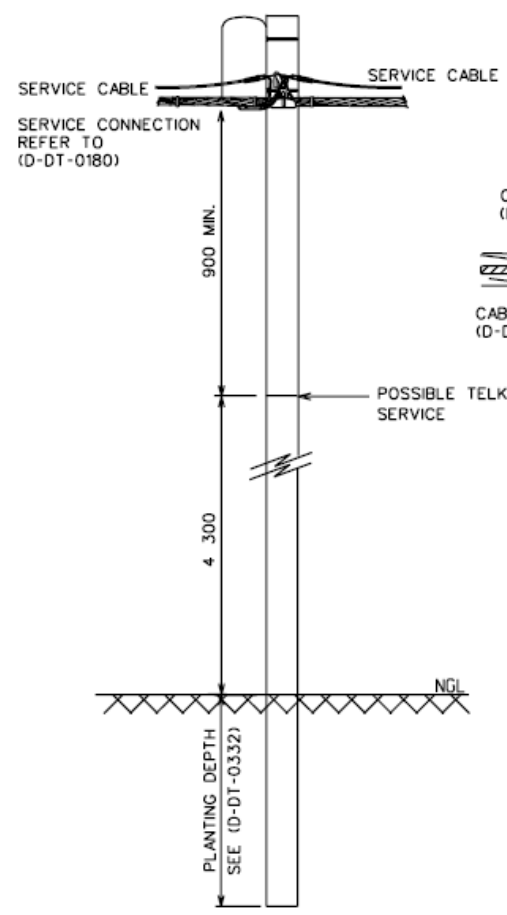

NOTE:
 1. EARTHING REQUIREMENTS SEE PART 2.
 2. STAY WIRE REQUIRED IF :
 - ANGLE GREATER THAN 5
 - TWO OR MORE SERVICES FROM ONE SIDE OF POLE.

4	LOGO CHANGED AS PER CORPORATE ID	M.T.M.	P.A.V.	J.SCHOLTZ	06.08.04	
3	TITLE CHANGED		P.A.V.	I.A.F.	I.A.F.	07/07/97
REV	REVISION DESCRIPTION	BY	CHKD	AUTH	DATE	PROJECT NO.

AUTH:	S.A. OLLIERS
DATE:	10/01/1994
CHKD:	N.J.V.R.
DATE:	01/03/1993
DRAWN:	N.J.V.R.
DATE:	15/02/1993

LV RETICULATION
THREE PHASE BARE NEUTRAL ABC
SUSPENSION ASSEMBLY (0° - 30°)
WOOD POLE

D-DT-1100	SET	SHEET	REVISION
	1	1	4

1 2 3 4 5 6 7 8 A3L

1 2 3 4 5 6 7 8

A
B
C
D
E
F

A
B
C
D
E
F

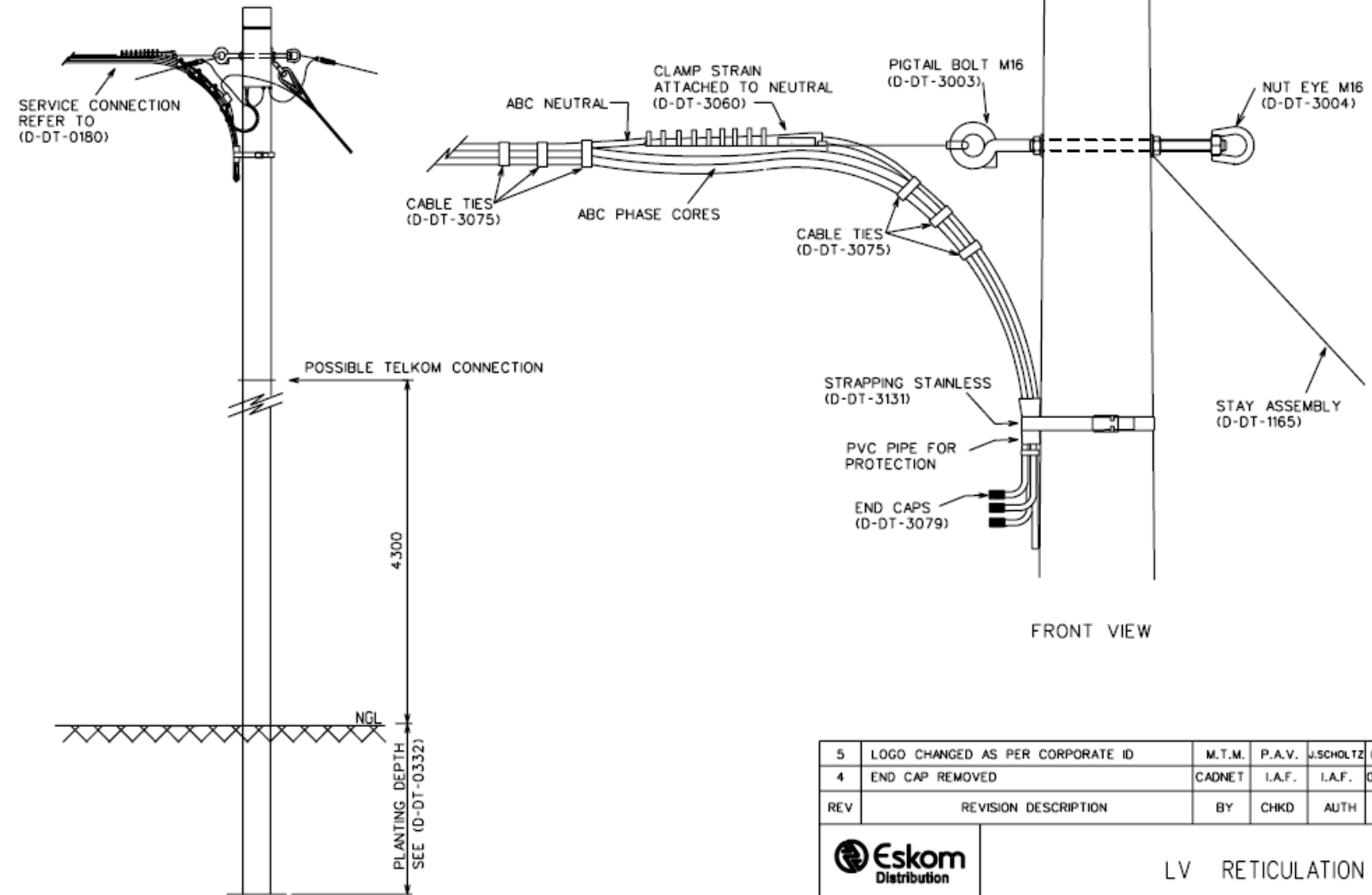

NOTE :
 1. EARTHING REQUIREMENTS
 SEE PART 2.
 2. IF TWO BUNDLES ARE USED
 INSTALL MV STAY (D-DT-1265)

5	LOGO CHANGED AS PER CORPORATE ID	M.T.M.	P.A.V.	J.SCHOLTZ	06.08.04	
4	END CAP REMOVED	CADNET	I.A.F.	I.A.F.	07/07/97	
REV	REVISION DESCRIPTION	BY	CHKD	AUTH	DATE	PROJECT NO.

AUTH:	S.A. OLLIERS
DATE:	10/01/1994
CHKD:	N.J.V.R.
DATE:	05/03/1993
DRAWN:	DT H.J.V.M.
DATE:	08/02/1993

LV RETICULATION			
THREE PHASE BARE NEUTRAL ABC TERMINAL ASSEMBLY WOOD POLE			
D-DT-1120	SET	SHEET	REVISION
	1	1	5

1 2 3 4 5 6 7 8 A3L

(1) TAX CLEARANCE STATUS PIN

NOTICE NO.: 101/2025
BID NUMBER: BID/NC062/18/2025-2026

Starting Date: 21/11/2025

Closing Date: 05/12/2025

Closing Time: 12:00 Midday

PLEASE ATTACH HERE

(2) SPECIFIC GOAL 1

NOTICE NO.: 101/2025
BID NUMBER: BID/NC062/18/2025-2026

Starting Date: 21/11/2025

Closing Date: 05/12/ 2025

Closing Time: 12:00 Midday

The bidder must submit the following three (3) documents to earn points out of 10 for the specific goal 1:

% Black ownership

1. Service Provider must submit proof of ownership of the enterprise or
1. Ownership Certificate issued by the Companies and Intellectual Property Commission
 2. Affidavit stating the race and % of the company's owner(s)
 3. Certified ID (not older than 6 months)

Failure to submit all 3 documents will result in 0 points allocation for specific goal 1.

PLEASE ATTACH HERE

(3) MUNICIPAL ACCOUNTS

NOTICE NO.: 101/2025
BID NUMBER: BID/NC062/18/2025-2026

Starting Date: 21/11/2025

Closing Date:05/12/2025

Closing Time: 12:00 Midday

**PLEASE ATTACH HERE ALL MUNICIPAL ACCOUNTS
OF COMPANY AND ITS DIRECTORS**

(5) CSD REGISTRATION REPORT

NOTICE NO.: 101/2025
BID NUMBER: BID/NC062/18/2025-2026

Starting Date: 21/11/ 2025

Closing Date: 05/12/2025

Closing Time: 12:00 Midday

PLEASE ATTACH HERE

(8) COMPANY PROFILE

NOTICE NO.: 101/2025
BID NUMBER: BID/NC062/18/2025-2026

Starting Date: 21/11/ 2025

Closing Date: 05/12/ 2025

Closing Time: 12:00 Midday

PLEASE ATTACH HERE