





DR JS MOROKA LOCAL MUNICIPALITY

CONTRACT NUMBER: JSM R02/26-27/W27

TENDER DOCUMENT

CONSTRUCTION OF KATJIBANE BUS AND TAXI ROUTE PHASE-5

PREPARED BY:	PREPARED FOR:
 <p>MORULA CONSULTING ENGINEERS</p> <p>54A Dorp Street Polokwane 0700</p> <p>Tel: (015) 291 1161 / (086) 558 6446</p> <p>Email: admin@morulaconsulting.co.za hulisani@morulaconsulting.co.za/ Thavha@morulaconsulting.co.za</p>	 <p>EXPANDED PUBLIC WORKS PROGRAMME Creating opportunities towards human fulfilment</p> <p>The Municipal Manager Dr J.S. Moroka Local Municipality</p> <p>P/Bag X 4012 SIYABUSWA 0472</p> <p>Tel: (013) 973 9126/7/8/9 Fax: (013) 973 9132/3</p>

NAME OF BIDDER (BIDDING ENTITY) (FULL NAME, i.e. (CC, (PTY) LTD, LTD, JV, SOLE PROPRIETOR etc.)

:

TEL NUMBER

:

CIBD NUMBER

:

CSD NO.

:

EMAIL ADDRESS

:

THE OFFERED TOTAL OF THE PRICES INCLUDING VALUE ADDED TAX IS:

R.....(In figures)

BIDDER:

DR. JSMLM:

1

Initial: Authorized signatory/ies:

1.

Initial: DR. JSMLM

.....

2.

Witness:



VERY IMPORTANT NOTICE ON DISQUALIFICATIONS:

A bid not complying with the peremptory requirements stated hereunder will be regarded as not being an "Acceptable bid", and as such will be rejected.

"Acceptable bid" means any bid which, in all respects, complies with the conditions of bid and specifications as set out in the bid documents, including conditions as specified in the Preferential Procurement Policy Framework Act (Act 5 of 2000) and related legislation as published in Government Gazette number 22549, dated 10 August 2022 including any other amendments made thereafter, in terms of which provision is made for this policy.

1. If a tax clearance pin or copy thereof (or in the case of a joint venture, of all the partners in the joint venture) has not been submitted with the bid document on closing date of the bid.
2. If any pages have been removed from the bid document, and have therefore not been submitted, or a copy of the original bid document has been submitted.
3. Failure to complete the schedule of quantities as required including the sub-contractors schedule of quantities.
4. Scratching out, writing over or painting out rates, without initialing next to the amended rates or information, affecting the evaluation of the bid.
5. The use of correction fluid (i.e. tippex) or any erasable ink, e.g. pencil.
6. Non-attendance of mandatory/compulsory:
 - o Site inspections or;
 - o Information/Clarification meetings
7. The Bid has not been properly signed by a party having the authority to do so, according to the example of "Authority for Signatory"
8. No authority for signatory submitted – See example, where it is stated that a duly signed and dated original or certified copy of the company's relevant resolution (for each specific bid) of their members or their board of directors on the company letter head, must be submitted.
9. Particulars required in respect of the bid have not been completed, except if information required on Preferencing Schedule in respect of HDI Equity and Equity Ownership Forms, is not completed, the bid will not be disqualified but no preference points will be awarded.
10. The bidder attempts to influence, or has in fact influenced the evaluation and/or awarding of the contract
11. The bid has been submitted either in the wrong bid box or after the relevant closing date and time
12. Failure to provide a valid certificate from the Department of Labour, or a declaration (Specific goals – "Equity ownership") by a designated employer that it complies with the Employment Equity Act 55 of 1998.
13. If any municipal rates and taxes or municipal service charges owed by the bidder or any of its directors to the municipality, or to any other municipality or municipal entity, are in arrears for more than one month.
14. If any bidder who during the last five years has failed to perform satisfactorily on a previous contract with the municipality, municipal entity or any other organ of state after written notice was given to that bidder that performance was unsatisfactory.
15. The accounting officer must ensure that irrespective of the procurement process followed, no award may be given to a person –
 - (a) who is in the service of the state, or;
 - (b) if that person is not a natural person, of which any director, manager, principal shareholder or stakeholder, is a person in the service of the state; or;
 - (c) Who is an advisor or consultant contracted with the municipality in respect of contract that would cause a conflict of interest.
16. Failure to provide:
 - (a) Written proof of **registration** with the CIDB, in an appropriate contractor grading designation (category), as required in the bid documentation (if applicable).

BIDDER:

DR. JSMLM:

Initial: Authorized signatory/ies:

1.

Initial: DR. JSMLM

2

2

Witness:



17. Bid offers will be rejected if the bidder or any of his directors is listed on the Register of Bid Defaulters in terms of the Prevention and Combating of Corrupt Activities Act of 2004 as a person prohibited from doing business with the public sector.
18. Bid offers will be rejected if the bidder has abused the DR. JSMLM's Supply Chain Management System.
19. Failure to attach a copy of a valid signed Joint Venture/Consortium agreement (if applicable) to the bid document.
20. Form of offer not completed and signed by the authorised signatory.
21. Not signing all pages on the space provided
22. Attach CV of Contracts Manager, Site Agent and Safety Officer
23. Attach certified copies of the following Key personnel:
 1. **Contracts Manager** Minimum National Diploma in Civil Engineering or equivalent NQF 6 and Professional registration (ECSA) PrEng/Tech/Technician.
 2. **Site Agent** Minimum Diploma in Civil Engineering NQF 6 or equivalent
 3. **Site Foreman** Minimum N6 in Civil Engineering or Equivalent
 4. **Safety Officer** Minimum Certificate in occupational or equivalent and professional registration in OHS (SACPCMP)
24. Proof of Foreign Qualification approved from SAQA (if applicable)
25. Proof of Employment, letter confirming employment on the company letter head (Contracts Manager, Site Agent and Safety Officer)
26. Proof of relevant working experience for the bidder (copies of appointment letter and completion certificate)
27. Recent **THREE YEARS** audited financial statement stating that the business is a going concern in line with Municipal Supply Chain Management Regulations are to be submitted.
28. In case where the bidder fails to prove beyond reasonable doubt that the project will be completed with the amount stated on the form offer. The bidder in the latter case will be given an opportunity to present the facts for risk mitigation purposes.
29. The municipality also reserves the right not to appoint the lowest bidder and to appoint the bid in whole or in parts. The municipality also reserves the right to appoint the bid based on its risk assessment.

NOTE:

IN THIS DOCUMENT AND OTHER DOCUMENTS REFERRED TO BUT NOT ATTACHED, THE FOLLOWING WORDS ARE SYNONYMOUS WITH EACH OTHER.

1. CLIENT, EMPLOYER, DR. JS MOROKA LOCAL MUNICIPALITY (DR. JSMLM).
2. BID, TENDER AND VARIATIONS THEREOF
3. JOINT VENTURE / CONSORTIUM

BIDDER:

DR. JSMLM:

Initial: Authorized signatory/ies:

1.

Initial: DR. JSMLM

3

.....

2

Witness:



DR. JS MOROKA LOCAL MUNICIPALITY

DEPARTMENT NAME: *TECHNICAL SERVICES*

CONTRACT NO: JSM R02/26-27/W27.

FOR THE

CONSTRUCTION OF KATJIBANE BUS AND TAXI ROUTE PHASE-5

SUMMARY FOR BID OPENING PURPOSES

NAME OF BIDDING ENTITY:.....

PHYSICAL STREET ADDRESS:	POSTAL ADDRESS:

TELEPHONE NUMBER :

FAX NUMBER :

E-mail ADDRESS :

CONTRACT PRICE : R
 (Amount brought forward from the Form of Offer and Acceptance) *

.....

Signed by authorised representative of the Bidding Entity..... DATE

- Should any discrepancy occur between this figure and that stated in the Form of Offer and Acceptance, the latter shall take precedence and apply.

BIDDER:

DR. JSMLM:

Initial: Authorized signatory/ies:

1.

Initial: DR. JSMLM

2

Witness:



DR. JS MOROKA LOCAL MUNICIPALITY

DEPARTMENT NAME: *TECHNICAL SERVICES*

CONTRACT NO: **JSM R02/25-26/W27**

FOR THE **CONSTRUCTION OF KATJIBANE BUS AND TAXI ROUTE PHASE-5**

NB This list of contents indicates the standard sequence for the various parts of the Bid.

CONTENTS	PAGE(S)
THE BID	
PART T1: BIDDING PROCEDURES.....	7
T1.1 Notice and Invitation to Bid	8
T1.2 Bid Data.....	9
PART T2: RETURNABLE DOCUMENTS	29
T2.1 Returnable Schedules required for Bid Evaluation Purposes	30
T2.2 Other Documents required for Bid Evaluation Purposes	45
T2.3 Returnable Schedules that will be incorporated in the Contract.....	64
THE CONTRACT	
PART C1: AGREEMENT AND CONTRACT DATA.....	75-98
C1.1 Form of Offer and Acceptance.....	77
C1.2 Contract Data	81
C1.3 Form of Guarantee.....	85
C1.4 Agreement in Terms of Occupational Health and Safety Act, 1993 (Act No 85 Of 1993)	91
PART C2: PRICING DATA.....	94
C2.1 Pricing Instructions	95
C2.2 Bill of Quantities/Schedule of Activities	97

BIDDER:

DR. JSMLM:

Initial: Authorized signatory/ies:

1.

Initial: DR. JSMLM

5

2

Witness:



DR. JS MOROKA LOCAL MUNICIPALITY

DEPARTMENT NAME: *TECHNICAL SERVICES*

CONTRACT NO: **JSM R02/26-27/W27**

FOR THE

CONSTRUCTION OF KATJIBANE BUS AND TAXI ROUTE PHASE-5

CONTENTS (CONTINUED)	PAGE(S)
PART C3: SCOPE OF WORKS	126
C3.1 DESCRIPTION OF WORKS	126
PART C4: SITE INFORMATION	134
PART C5: ADDITIONAL RELEVANT DOCUMENTATION	185
PART C6: TENDER DRAWINGS	186

BIDDER:

DR. JSMLM:

Initial: Authorized signatory/ies:

1.

Initial: DR. JSMLM

6

.....

2

Witness:



T . 1

DR. JS MOROKA LOCAL MUNICIPALITY

DEPARTMENT NAME: *TECHNICAL SERVICES*

CONTRACT NO: **JSM R02/26-27/W27**

FOR THE **CONSTRUCTION OF KATJIBANE BUS AND TAXI ROUTE PHASE-5**

PART T1	BIDDING PROCEDURES	PAGE(S)
T1.1	BID NOTICE AND INVITATION TO BID	8
T1.2	BID DATA.....	9

BIDDER:

DR. JSMLM:

Initial: Authorized signatory/ies:
.....

1.

Initial: DR. JSMLM

7

2

Witness:



T1.1 BID NOTICE AND INVITATION TO BID



DR JS MOROKA LOCAL MUNICIPALITY

INVITATION TO CONTRACTORS

Tenders are hereby invited from Contractors with necessary experience and compliance documents, have an active **CIDB grading of a minimum 5CE OR HIGHER** and are in good standing with the South African Revenue Services for the **CONSTRUCTION OF KATJIBANE BUS AND TAXI ROUTE PHASE-5**.

Tender documents will only be available from **02 July 2026** and may be obtained from Dr JS Moroka Municipal Head Quarters at the cashier offices situated 2601/3 Bongimfundo Street, Siyabuswa during working hours 09h00 to 15h00 (Monday to Friday), upon payment of a non-refundable fee of **R3 516.32 per document** or on E-Tenders. Only cash and speed point payment are to be made payable to Dr JS Moroka Municipality. No tender documents will be sold beyond these dates.

A Compulsory Site meeting and Inspection will be held on 07 July 2026 at DR JS Moroka Ga- Phaahla Community Hall, commencing at 10h30 (According to Municipality's time) after which Tenderers will be taken to site where project's construction will be taking place. Only tenders from Tenderers who attend the above tender meeting and have signed attendance register shall be considered.

All tenders and supporting documents shall be sealed in an envelope or package clearly marked **"Contract No: JSM R02/26-27/W27 for CONSTRUCTION OF KATJIBANE BUS AND TAXI ROUTE PHASE-5"**.

Duly completed tenders shall be placed in the tender box situated at the main entrance of Dr JS Moroka Local Municipality at 2601/3 Bongimfundo Street, Siyabuswa. No Fax or Late tenders will be accepted. Tenders will be evaluated on an 80/20-point system in terms of Dr JS Moroka Municipality's Supply Chain Management Policy in line with Preferential Procurement Framework Act 5 of 2000 including any other amendments made thereafter.

Technical Enquiries: Mr. M Z Skosana on (013) 973 9130; SCM Enquiries: Mr. A Masilela on (013) 9731101 from 07H45 to 16H15 Monday to Friday.

In all cases, Tenders shall reach the stipulated address not later than 11h00 on 03 August 2026 when tenders shall be opened and read in public.

**Ms. MM Mathebela – Municipal Manager
Dr JS Moroka Local Municipality**

BIDDER:

DR. JSMLM:

Initial: Authorized signatory/ies:

1.

Initial: DR. JSMLM

8

.....

2

Witness:



T1.2 BID DATA

The **Standard Conditions of Bid** for Procurements makes several references to the bid data for details that apply specifically to this bid. The bid data shall have precedence in the interpretation of any ambiguity or inconsistency between it and the standard conditions of bid.

Clause number	Data
F.1.1 ACTIONS	The Employer is: The Municipal Manager Dr. JS Moroka Local Municipality 2601/3 Bongimfundo Street Private Bag X4012 Siyabuswa 0472
F.1.2 TENDER DOCUMENTS	The bid documents issued by the Employer comprise: THE BID Part T1 Bidding procedures Part T1.1 Bid notice and invitation to bid Part T1.2 Bid data Part T2 Returnable documents Part T2.1 List of returnable documents Part T2.2 Returnable schedules THE CONTRACT Part C1 Agreements and contract data C1.1 Form of offer and acceptance C1.2 Contract data C1.3 Form of Guarantee C1.4 Agreement in terms of Occupational Health and Safety Act, 1993 Part C2 Pricing Data C2.1 Pricing Instructions C2.2 Bill of Quantity Part C3 Scope of Works C3 Scope of Works Part C4 Site Information C4 Site Information
F.1.4 COMMUNICATION AND EMPLOYER'S AGENT	(Compiler: MORULA CONSULTING ENGINEERS  The Employer's agent is: Name: Mr. H.O TSANWANI Address: 54 Dorp Street , POLOKWANE,0700 Tel : (087) 821 7033/ (015) 291 1161 Email: admin@morulaconsulting.co.za / hulisani@morulaconsulting.co.za / Thavha@morulaconsulting.co.za

BIDDER:

DR. JSMLM:

Initial: Authorized signatory/ies:

1.

Initial: DR. JSMLM

9

.....

2

Witness:



Clause number	Data
<p>F.2.1 ELIGIBILITY</p>	<p>Only those tenderers who are registered with the CIDB, or are capable of being so prior to the evaluation of submissions, in a contractor grading designation equal to or higher than a contractor grading designation determined in accordance with the sum tendered, or a value determined in accordance with Regulation 25 (1B) or 25(7A) of the Construction Industry Development Regulations, for a 5CE or higher class of construction work, are eligible to have their tenders evaluated up to a maximum of R10.0 million.</p> <p>Joint Ventures are eligible to submit tenders provided that:</p> <ol style="list-style-type: none"> 1. Every member of the joint venture is registered with the CIDB; 2. The lead partner has a contractor grading designation in the 5CE class of construction work; and 3. The combined contractor grading designation calculated in accordance with the Construction Industry Development Regulations is equal to or higher than a contractor grading designation determined in accordance with the sum tendered for a 5CE class of construction work or a value determined in accordance with Regulation 25 (1B) or 25(7A) of the Construction Industry Development Regulations. <p>Accept that only those tenderers with a bank rating of not less than a "C" can be considered for evaluation.</p>
	<p>The arrangements for a compulsory clarification meeting are: Location: Dr JS Moroka Ga-Phaahla Community Hall. 25°07'33.53"S 29°03'27.63"E Date: 07 July 2026 @ 10h30</p>
<p>F.2.13.2 SUBMITTING A TENDER OFFER</p>	<p>Each tenderer is required to return the complete set of documents as listed in the Tender data with all the required information supplied and completed in all respects.</p>
<p>F.2.13.3 SUBMITTING A TENDER OFFER</p>	<p>The <u>whole original</u> bid document, <i>as issued by the DR. JSMLM</i>, shall be submitted. <i>No copies will be accepted.</i></p> <p>Bids may only be submitted on the Bid documentation issued by the Dr. JSMLM.</p>
<p>F.2.13.5 SUBMITTING A TENDER OFFER</p>	<p>The Employer's address for delivery of bid offers and identification details to be shown on each bid offer package are:</p> <p>Location of bid box: Main Gate Physical address: Dr. JS Moroka Local Municipality 2601/3 Bongimfundo Street Private Bag X4012 Siyabuswa 0472</p> <p>Identification details: Contract Number: "Contract No: JSM R02/26-27/W27 for CONSTRUCTION OF KATJIBANE BUS AND TAXI ROUTE PHASE-5"</p>

BIDDER:

DR. JSMLM:

Initial: Authorized signatory/ies:

1.

Initial: DR. JSMLM

10

.....

2

Witness:



Clause number	Data
F.2.15 CLOSING TIME	The Closing Time for submission of bid offers is: 11h00, 03 August 2026 Telephonic, telegraphic, telex, facsimile or e-mailed bid offers will not be accepted.
F.2.16 TENDER OFFER VALIDITY	The bid offer validity period is 90 days
F.2.18 PROVIDE OTHER MATERIAL	The bidder shall, when requested by the Employer to do so, submit the names of all management and supervisory staff that will be employed to supervise the Labour-intensive portion of the works together with satisfactory evidence that such staff members satisfy the eligibility requirements
F.2.19 INSPECTIONS, TESTS AND ANALYSIS	Access must be provided for the inspection of the tenderer's offices if required.
F.2.23 CERTIFICATES	The bidder is required to submit with his bid. (1) a copy of the valid Certificate of Contractor Registration issued by the Construction Industry Development Board in terms of the Construction Industry Development Board Act (Form F006); and (2) an original Tax Clearance Pin or copy thereof, issued by the South African Revenue Services (3) a copy of the valid National Diploma Certificate for Contractor's Safety Officer in terms of OH/S Act (85/1993) section 16(2)
F3.4 OPENING OF BID SUBMISSIONS	The time and location for opening of the bid offers are: Immediately after the closing time for submission of bid. Location: Dr. JS Moroka Local Municipality 2601/3 Bongimfundo Street Private Bag X4012 Siyabuswa, 0472
F.3.5 TWO-ENVELOPE SYSTEM	A two-envelope procedure will not be followed.
F.3.9 3.9.1 ARITHMETICAL ERRORS	Replace the contents of the clause with the following: "Check responsive tender offers for arithmetical errors, correcting them in the following manner: a) Where there is a discrepancy between the amounts in figures and in words, the amount in figures shall govern. b) If bills of quantities (or schedule of quantities or schedule of rates) apply and there is an error in the line-item total resulting from the product of the unit rate and the quantity, <u>the rate shall govern and the line-item total shall be corrected.</u> c) Where there is an error in the total of the prices either as a result of

BIDDER:

DR. JSMLM:

Initial: Authorized signatory/ies:

1.

Initial: DR. JSMLM

11

.....

2

Witness:



Clause number	Data
3.9.2	<p>corrections required by this checking process or in the tenderer's addition of prices, the total of the prices shall be adjusted to reflect the arithmetically correct summation of corrected line item totals.</p> <p>Consider the rejection of a tender offer if the tenderer does not accept the correction of the arithmetical errors in the manner described above.”</p>
F.3.11 EVALUATION OF BID OFFERS	<p>The preference procedure for evaluation of responsive bid offers shall be the 80/20 point preference system, in full compliance with Form 2.3.3. Technical and general criteria will be evaluated in terms of paragraph 2.3.3.10</p>
F.3.13.1 ACCEPTANCE OF BID OFFER	<p>Bids containing any one or more of the errors or omissions, or bids not having complied with any one of the peremptory bid conditions as detailed on page 2 of this bid document, shall not be considered and shall automatically be rejected.</p>
F.3.18 PROVIDE COPIES OF THE CONTRACTS	<p>The number of paper copies of the signed contract to be provided by the Employer is one.</p>
<p>ADDITIONAL CONDITIONS APPLICABLE TO THIS BID</p>	<p>The additional conditions of bid are:</p> <ol style="list-style-type: none"> 1 The Employer may also request that the bidder provide written evidence that his financial, labour and other resources are adequate for carrying out the contract. 2 The Employer reserves the right to appoint a firm of chartered accountants and auditors and/or execute any other financial investigations on the financial resources of any bidder. The bidder shall provide all reasonable assistance in such investigations. 3 The bidder shall be required to complete the Form of Offer and Acceptance (C1.1) and Bills of Quantity for all the region or regions for which they intend to bid for. 4 The bid document shall be submitted as a whole and shall not be taken apart. 5 List of returnable documents (PART T2) must be completed in full. (A bidder's company profile will not be used by the DR. JSMLM to complete PART T2 on behalf of the bidder) <p>NB: If PART T2 is not completed in full by the bidder, this offer will be rejected.</p>

BIDDER:

DR. JSMLM:

Initial: Authorized signatory/ies:

1.

Initial: DR. JSMLM

12

.....

2

Witness:



Annex F (Normative) Standard Conditions of Tender

- Note: 1 These Standard Conditions of Tender are identical to that contained In Annex F of SANS 294: 2004, *Construction Procurement Processes, Procedures and Methods*.
2 Annex E of SANS 294, *Construction Procurement Processes, Procedures and Methods*, and SAICE's Practice Manual #1, *The use of South African National Standards in Construction Procurement*, provide guidance on referencing these Standard Conditions of Tender in procurement documents.

F.1 General

F.1.1 Actions

The employer and each tenderer submitting a tender offer shall comply with these conditions of tender. In their dealings with each other, they shall discharge their duties and obligations as set out in F.2 and F.3, timeously and with integrity, and behave equitably, honestly and transparently.

F.1.2 Tender Documents

The documents issued by the employer for the purpose of a tender offer are listed in the tender data.

F.1.3 Interpretation

F.1.3.1 The tender data and additional requirements contained in the tender schedules that are included in the returnable documents are deemed to be part of these conditions of tender.

F.1.3.2 These conditions of tender, the tender data and tender schedules which are only required for tender evaluation purposes, shall not form part of any contract arising from the invitation to tender.

F.1.3.3 For the purposes of these conditions for the calling for expressions of interest, the following definitions apply:

- a) comparative offer means the tenderer's financial offer after the factors of non-firm prices, all unconditional discounts and any other tendered parameters that will affect the value of the financial offer have been taken into consideration
- b) corrupt practice means the offering, giving, receiving or soliciting of anything of value to influence the action of the employer or his staff or agents in the tender process; and
- c) fraudulent practice means the misrepresentation of the facts in order to influence the tender process or the award of a contract arising from a tender offer to the detriment of the employer, including collusive practices intended to establish price sat artificial levels quality (functionality) means the totality of features and characteristics of a product or service that bear on its ability to satisfy stated or implied needs

BIDDER:

DR. JSMLM:

Initial: Authorized signatory/ies:

1.

Initial: DR. JSMLM

13

.....

2.

Witness:



F.1.4 Communication and employer's agent

Each communication between the employer and a tenderer shall be to or from the employer's agent only, and in a form that can be read, copied and recorded. Writing shall be in the English language. The employer shall not take any responsibility for non-receipt of communications from or by a tenderer. The name and contact details of the employer's agent are stated in the tender data.

F.1.5 The employer's right to accept or reject any tender offer

F.1.5.1 The employer may accept or reject any variation, deviation, tender offer, or alternative tender offer, and may cancel the tender process and reject all tender offers at any time before the formation of a contract. The employer shall not accept or incur any liability to a tenderer for such cancellation and rejection but will give written reasons for such action upon written request to do so.

F.1.5.2 The employer may not subsequent to the cancellation or abandonment of a tender process or the rejection of all responsive tender offers re-issue a tender covering substantially the same scope of work within a period of six months unless only one tender was received and such tender was returned unopened to the tenderer.

F.2 Tenderer's obligations

F.2.1 Eligibility

Submit a tender offer only if the tenderer satisfies the criteria stated in the tender data and the tenderer, or any of his principals, is not under any restriction to do business with employer.

F.2.2 Cost of tendering

Accept that the employer will not compensate the tenderer for any costs incurred in the preparation and submission of a tender offer, including the costs of any testing necessary to demonstrate that aspects of the offer satisfy requirements.

F.2.3 Check documents

Check the tender documents on receipt for completeness and notify the employer of any discrepancy or omission.

F.2.4 Confidentiality and copyright of documents

Treat as confidential all matters arising in connection with the tender. Use and copy the documents issued by the employer only for the purpose of preparing and submitting a tender offer in response to the invitation.

F.2.5 Reference documents

Obtain, as necessary for submitting a tender offer, copies of the latest versions of standards, specifications, conditions of contract and other publications, which are not attached but which are incorporated into the tender documents by reference.

BIDDER:

DR. JSMLM:

Initial: Authorized signatory/ies:

1.

Initial: DR. JSMLM

14

.....

2.

Witness:



F.2.6 Acknowledge addenda

Acknowledge receipt of addenda to the tender documents, which the employer may issue, and if necessary apply for an extension to the closing time stated in the tender data, in order to take the addenda into account.

F.2.7 Clarification meeting

Attend, where required, a clarification meeting at which tenderers may familiarize themselves with aspects of the proposed work, services or supply and raise questions. Details of the meeting are stated in the tender data.

F.2.8 Seek clarification

Request clarification of the tender documents, if necessary, by notifying the employer at least five working days before the closing time stated in the tender data.

F.2.9 Insurance

Be aware that the extent of insurance to be provided by the employer (if any) might not be for the full cover required in terms of the conditions of contract identified in the contract data. The tenderer is advised to seek qualified advice regarding insurance.

F.2.10 Pricing the tender offer

F.2.10.1 Include in the rates, prices, and the tendered total of the prices (if any) all duties, taxes (except Value Added Tax (VAT), and other levies payable by the successful tenderer, such duties, taxes and levies being those applicable 14 days before the closing time stated in the tender data.

F.2.10.2 Show VAT payable by the employer separately as an addition to the tendered total of the prices.

F.2.10.3 Provide rates and prices that are fixed for the duration of the contract and not subject to adjustment except as provided for in the conditions of contract identified in the contract data

F.2.10.4 State the rates and prices in Rand unless instructed otherwise in the tender data. The conditions of contract identified in the contract data may provide for part payment in other currencies.

F.2.11 Alterations to documents

Not make any alterations or additions to the tender documents, except to comply with instructions issued by the employer, or necessary to correct errors made by the tenderer. All signatories to the tender offer shall initial all such alterations. Erasures and the use of masking fluid are prohibited.

F.2.12 Alternative tender offers

F.2.12.1 Submit alternative tender offers only if a main tender offer, strictly in accordance with all the requirements of the tender documents, is also submitted. The alternative tender offer is to be submitted with the main tender offer together with a schedule that compares the requirements of the tender documents with the alternative requirements the tenderer proposes.

BIDDER:

DR. JSMLM:

Initial: Authorized signatory/ies:
.....

1.

Initial: DR. JSMLM

2.

Witness:



F.2.12.2 Accept that an alternative tender offer may be based only on the criteria stated in the tender data or criteria otherwise acceptable to the employer.

F.2.13 Submitting a tender offer

F.2.13.1 Submit a tender offer to provide the whole of the works, services or supply identified in the contract data and described in the scope of works, unless stated otherwise in the tender data.

F.2.13.2 Return all returnable documents to the employer after completing them in their entirety, either electronically (if they were issued in electronic format) or by writing in Mack ink.

F.2.13.3 Submit the parts of the tender offer communicated on paper as an original plus the number of copies stated in the tender data, with an English translation of any documentation in a language other than English, and the parts communicated electronically in the same format as they were issued by the employer.

F.2.13.4 Sign the original and all copies of the tender offer where required in terms of the tender data.

The employer will hold all authorized signatories liable on behalf of the tenderer. Signatories for tenderers proposing to contract as joint ventures shall state which of the signatories is the lead partner whom the employer shall hold liable for the purpose of the tender offer.

F.2.13.5 Seal the original tender document together with all returnable documents as one package. The package shall state on the outside the employer's address and identification details stated in the tender data, as well as the tenderer's name and contact address.

F.2.13.6 Where a two-envelope system is required in terms of the tender data, place and seal the returnable documents listed in the tender data in an envelope marked "financial proposal" and place the remaining returnable documents in an envelope marked "technical proposal". Each envelope shall state on the outside the employer's address and identification details stated in the tender data, as well as the tenderer's name and contact address.

F.2.13.7 Seal the original tender offer and returnable documents packages together in an outer package that states on the outside only the employer's address and identification details as stated in the tender data.

F.2.13.8 Accept that the employer will not assume any responsibility for the misplacement or premature opening of the tender offer if the outer package is not sealed and marked as stated.

F.2.14 Information and data to be completed in all respects

Accept that tender offers, which do not provide all the data or information requested completely and in the form required, may be regarded by the employer as non-responsive.

BIDDER:

DR. JSMLM:

Initial: Authorized signatory/ies:
.....

1.

Initial: DR. JSMLM

2.

Witness:



F.2.15 Closing time

F.2.15.1 Ensure that the employer receives the tender offer at the address specified in the tender data not later than the closing time stated in the tender data. Proof of posting shall not be accepted as proof of delivery. The employer shall not accept tender offers submitted by telegraph, telex, facsimile or e-mail, unless stated otherwise in the tender data.

F.2.15.2 Accept that, if the employer extends the closing time stated in the tender data for any reason, the requirements of these conditions of tender apply equally to the extended deadline.

F.2.16 Tender offer validity

F.2.16.1 Hold the tender offer(s) valid for acceptance by the employer at any time during the validity period stated in the tender data after the closing time stated in the tender data.

F.2.16.2 If requested by the employer, consider extending the validity period stated in the tender data for an agreed additional period.

F.2.17 Clarification of tender offer after submission

Provide clarification of a tender offer in response to a request to do so from the employer during the evaluation of tender offers. This may include providing a breakdown of rates or prices and correction of arithmetical errors by the adjustment of certain rates or item prices (Or both). No change in the competitive position of tenderers or substance of the tender offer is sought, offered, or permitted.

Note: Sub-clause F.2.17 does not preclude the negotiation of the final terms of the contract with a preferred tenderer following a competitive selection process, should the Employer elect to do so.

F.2.18 Provide other material

F.2.18.1 Provide, on request by the employer, any other material that has a bearing on the tender offer, the tenderer's commercial position (including notarized joint venture agreements), preferencing arrangements, or samples of materials, considered necessary by the employer for the purpose of a full and fair risk assessment. Should the tenderer not provide the material, or a satisfactory reason as to why it cannot be provided, by the time for submission stated in the employer's request, the employer may regard the tender offer as non-responsive.

F.2.18.2 Dispose of samples of materials provided for evaluation by the employer, where required.

F.2.19 Inspections, tests and analysis

Provide access during working hours to premises for inspections, tests and analysis as provided for in the tender data.

F.2.20 Submit securities, bonds, policies, etc.

If requested, submit for the employer's acceptance before formation of the contract, all securities, bonds, guarantees, policies and certificates of insurance required in terms of the conditions of contract identified in the contract data.

F.2.21 Check final draft

Check the final draft of the contract provided by the employer within the time available

BIDDER:

DR. JSMLM:

Initial: Authorized signatory/ies:

1.

Initial: DR. JSMLM

17

.....

2.

Witness:



for the employer to issue the contract. Return of other tender documents
If so instructed by the employer, return all retained tender documents within 28 days after
the expiry of the validity period stated in the tender data

F.2.22 Certificates

Include in the tender submission or provide the employer with any certificates as stated
in the tender data.

F.3 The employer's undertakings

F.3.1 Respond to clarification

Respond to a request for clarification received up to five working days before the tender
closing time stated in the Tender Data and notify all tenderers who drew procurement
documents.

F.3.2 Issue Addenda

If necessary, issue addenda that may amend or amplify the tender documents to each
tenderer during the period from the date that tender documents are available until seven
days before the tender closing time stated in the Tender Data. If, as a result a tenderer
applies for an extension to the closing time stated in the Tender Data, the Employer may
grant such extension and, shall then notify all tenderers who drew documents.

F.3.3 Return late tender offers

Return tender offers received after the closing time stated in the Tender Data, unopened,
(unless it is necessary to open a tender submission to obtain a forwarding address), to
the tenderer concerned.

F.3.4 Opening of tender submissions

F.3.4.1 Unless the two-envelope system is to be followed, open valid tender submissions in the
presence of tenderers' agents who choose to attend at the time and place stated in the
tender data. Tender submissions for which acceptable reasons for withdrawal have been
submitted will not be opened.

F.3.4.2 Announce at the meeting held immediately after the opening of tender submissions, at
a venue indicated in the tender data, the name of each tenderer whose tender offer is
opened, the total of his prices, preferences claimed and time for completion, if any, for
the main tender offer only.

F.3.4.3 Make available the record outlined in F.3.4.2 to all interested persons upon request.

F.3.5 Two-envelope system

F.3.5.1 Where stated in the tender data that a two-envelope system is to be followed, open Only
the technical proposal of valid tenders in the presence of tenderers' agents who choose
to attend at the time and place stated in the tender data and announce the name of each
tenderer whose technical proposal is opened.

F.3.5.2 Evaluate the quality of the technical proposals offered by tenderers, then advice
tenderers who remain in contention for the award of the contract of the time and place
when the financial proposals will be opened. Open only the financial proposals of
tenderers, who score in the quality evaluation more than the minimum number of points

BIDDER:

DR. JSMLM:

Initial: Authorized signatory/ies:
.....

1.

Initial: DR. JSMLM

2.

Witness:



for quality stated in the tender data, and announce the score obtained for the technical proposals and the total price and any preferences claimed. Return unopened financial proposals to tenderers whose technical proposals failed to achieve the minimum number of points for quality.

F.3.6 Nondisclosure

Not disclose to tenderers, or to any other person not officially concerned with such processes, information relating to the evaluation and comparison of tender offers, the final evaluation price and recommendations for the award of a contract, until after the award of the contract to the successful tenderer.

F.3.7 Grounds for rejection and disqualification

Determine whether there has been any effort by a tenderer to influence the processing of tender offers and instantly disqualify a tenderer (and his tender offer) if it is established that he engaged in corrupt or fraudulent practices.

F.3.8 Test for responsiveness

F.3.8.1 Determine, after opening and before detailed evaluation, whether each tender offer properly received:

- a) complies with the requirements of these Conditions of Tender,
- b) has been properly and fully completed and signed, and
- c) is responsive to the other requirements of the tender documents.

F.3.8.2 A responsive tender is one that conforms to all the terms, conditions, and specifications of the tender documents without material deviation or qualification. A material deviation or qualification is one which, in the Employer's opinion, would:

- a) detrimentally affect the scope, quality, or performance of the works, services or supply identified in the Scope of Work,
- b) change the Employer's or the tenderer's risks and responsibilities under the contract, or
- c) affect the competitive position of other tenderers presenting responsive tenders, if it were to be rectified.

Reject a non-responsive tender offer, and not allow it to be subsequently made responsive by correction or withdrawal of the non-conforming deviation or reservation.

F.3.9 Arithmetical errors

F.3.9.1 Check responsive tender offers for arithmetical errors, correcting them in the following manner:

- a) Where there is a discrepancy between the amounts in figures and in words, the amount in words shall govern.
- b) If bills of quantities (or schedule of quantities or schedule of rates) apply and there is an error in the line item total resulting from the product of the unit rate and the quantity, the line item total shall govern and the rate shall be corrected. Where

BIDDER:

DR. JSMLM:

Initial: Authorized signatory/ies:
.....

1.

Initial: DR. JSMLM

2.

Witness:



there is an obviously gross misplacement of the decimal point in the unit rate, the line-item total as quoted shall be corrected and the unit rate shall govern.

- c) Where there is an error in the total of the prices either as a result of other corrections required by this checking process or in the tenderer's addition of prices, the total of the prices shall govern and the tenderer will be asked to revise selected item prices (and their rates if bills of quantities apply) to achieve the tendered total of the prices.

F.3.9.2 Consider the rejection of a tender offer if the tenderer does not correct or accept the correction of his arithmetical errors in the manner described in F.3.9.1.

F.3.10 Clarification of a tender offer

Obtain clarification from a tenderer on any matter that could give rise to ambiguity in a contract arising from the tender offer.

F.3.11 Evaluation of tender offers

Evaluation Criteria

BIDDER:

DR. JSMLM:

Initial: Authorized signatory/ies:
.....

1.

Initial: DR. JSMLM

2.

Witness:



MBD 6.1

PREFERENCE POINTS CLAIM FORM IN TERMS OF THE PREFERENTIAL PROCUREMENT REGULATIONS 2022

This preference form must form part of all tenders invited. It contains general information and serves as a claim form for preference points for specific goals.

NB: BEFORE COMPLETING THIS FORM, TENDERERS MUST STUDY THE GENERAL CONDITIONS, DEFINITIONS AND DIRECTIVES APPLICABLE IN RESPECT OF THE TENDER AND PREFERENTIAL PROCUREMENT REGULATIONS 2022

1. GENERAL CONDITIONS

2.

2.1 The following preference point systems are applicable to invitations to tender:

- the 80/20 system for requirements with a Rand value of up to R50 000 000 (all applicable taxes included); and
- the 90/10 system for requirements with a Rand value above R50 000 000 (all applicable taxes included).

2.2 To be completed by the organ of state

a) The applicable preference point system for this tender is the **80/20** preference point system.

b) 80/20 preference point system will be applicable in this tender. The lowest/ highest acceptable tender will be used to determine the accurate system once tenders are received.

2.3 Points for this tender (even in the case of a tender for income-generating contracts) shall be awarded for:

- (a) Price; and
- (b) Specific Goals.

1.4 To be completed by the organ of state:

The maximum points for this tender are allocated as follows:

	POINTS
PRICE	80
SPECIFIC GOALS	20
Total points for PRICE and SPECIFIC GOALS	100

BIDDER:

DR. JSMLM:

Initial: Authorized signatory/ies:

1.

Initial: DR. JSMLM

2.

Witness:



The specific goals based on the IDP for Dr JS Moroka local municipality are as per following.

- a) Empowerment of women
- b) Empowerment of youth
- c) Empowerment of previously disadvantaged communities
- d) BBBEE status level of contribution
- e) Empowerment of business established in the municipal jurisdiction.
- f) Military veterans in line with Act no 18 of 2011

For this Tender, specific goals shall be awarded as follows:

- a) Empowerment of business established in the municipal jurisdiction (5 points)
- b) Empowerment of youth (5 points)
- c) Empowerment of Disabled persons (5 points)
- d) Military veterans in line with Act no 18 of 2011(5 points)

- 1.5 Failure on the part of a tenderer to submit proof or documentation required in terms of this tender to claim points for specific goals with the tender, will be interpreted to mean that preference points for specific goals are not claimed.
- 1.6 The organ of state reserves the right to require of a tenderer, either before a tender is adjudicated or at any time subsequently, to substantiate any claim in regard to preferences, in any manner required by the organ of state.

3. DEFINITIONS

- (a) **“tender”** means a written offer in the form determined by an organ of state in response to an invitation to provide goods or services through price quotations, competitive tendering process or any other method envisaged in legislation.
- (b) **“price”** means an amount of money tendered for goods or services, and includes all applicable taxes less all unconditional discounts;
- (c) **“rand value”** means the total estimated value of a contract in Rand, calculated at the time of bid invitation, and includes all applicable taxes;
- (d) **“tender for income-generating contracts”** means a written offer in the form determined by an organ of state in response to an invitation for the origination of income-generating contracts through any method envisaged in legislation that will result in a legal agreement between the organ of state and a third party that produces revenue for the organ of state, and includes, but is not limited to, leasing and disposal of assets and concession contracts, excluding direct sales and disposal of assets through public auctions; and
- (e) **“the Act”** means the Preferential Procurement Policy Framework Act, 2022 (Act No. 5 of 2000) including any other amendments made thereafter.

BIDDER:

DR. JSMLM:

Initial: Authorized signatory/ies:

1.

Initial: DR. JSMLM

22

2

Witness:



4. FORMULAE FOR PROCUREMENT OF GOODS AND SERVICES

3.1. POINTS AWARDED FOR PRICE

3.1.1 THE 80/20 OR 90/10 PREFERENCE POINT SYSTEMS

A maximum of 80 or 90 points is allocated for price on the following basis:

$$Ps = 80 \left(1 - \frac{Pt - P_{min}}{P_{min}} \right) \quad \text{or} \quad Ps = 90 \left(1 - \frac{Pt - P_{min}}{P_{min}} \right)$$

80/20
or
90/10

Where

Ps = Points scored for price of tender under consideration

Pt = Price of tender under consideration

Pmin = Price of lowest acceptable tender

3.2. FORMULAE FOR DISPOSAL OR LEASING OF STATE ASSETS AND INCOME GENERATING PROCUREMENT

POINTS AWARDED FOR PRICE

A maximum of 80 or 90 points is allocated for price on the following basis:

$$Ps = 80 \left(1 + \frac{Pt - P_{max}}{P_{max}} \right) \quad \text{or} \quad Ps = 90 \left(1 + \frac{Pt - P_{max}}{P_{max}} \right)$$

80/20
or
90/10

Where

Ps = Points scored for price of tender under consideration

Pt = Price of tender under consideration

Pmax = Price of highest acceptable tender

5. POINTS AWARDED FOR SPECIFIC GOALS

4.1. In terms of Regulation 4(2); 5(2); 6(2) and 7(2) of the Preferential Procurement Regulations, preference points must be awarded for specific goals stated in the tender. For the purposes of this tender the tenderer will be allocated points based on the goals stated in table 1 below as may be supported by proof/ documentation stated in the conditions of this tender:

BIDDER:

DR. JSMLM:

Initial: Authorized signatory/ies:

1.

Initial: DR. JSMLM

2.

Witness:



- 4.2. In cases where organs of state intend to use Regulation 3(2) of the Regulations, which states that, if it is unclear whether the 80/20 or 90/10 preference point system applies, an organ of state must, in the tender documents, stipulate in the case of—

BIDDER:

Initial: Authorized signatory/ies:
.....

DR. JSMLM:

1.
2

Initial: DR. JSMLM

Witness:



- (a) an invitation for tender for income-generating contracts, that either the 80/20 or 90/10 preference point system will apply and that the highest acceptable tender will be used to determine the applicable preference point system; or
- (b) any other invitation for tender, that either the 80/20 or 90/10 preference point system will apply and that the lowest acceptable tender will be used to determine the applicable preference point system, then the organ of state must indicate the points allocated for specific goals for both the 90/10 and 80/20 preference point system.

Table 1: Specific goals for the tender and points claimed are indicated per the table below.

(Note to organs of state: Where either the 90/10 or 80/20 preference point system is applicable, corresponding points must also be indicated as such.

Note to tenderers: The tenderer must indicate how they claim points for each preference point system.)

The specific goals allocated points in terms of this tender	Number of points allocated (90/10 system) (To be completed by the organ of state)	Number of points allocated (80/20 system) (To be completed by the organ of state)	Number of points claimed (90/10 system) (To be completed by the tenderer)	Number of points claimed (80/20 system) (To be completed by the tenderer)
a) Empowerment of business established in the municipal jurisdiction (5 points)	N/A	5	N/A	
b) Empowerment of youth (5 points)	N/A	5	N/A	
c) Empowerment disabled persons (5points)	N/A	5	N/A	
d) Millitary veterans in line with Act no 18 of 2011(5 points)	N/A	5	N/A	

BIDDER:

DR. JSMLM:

Initial: Authorized signatory/ies:

1.

Initial: DR. JSMLM

2.

Witness:



DECLARATION WITH REGARD TO COMPANY/FIRM

4.3. Name of company/firm.....

4.4. Company registration number:

4.5. TYPE OF COMPANY/ FIRM

- Partnership/Joint Venture / Consortium
- One-person business/sole propriety
- Close corporation
- Public Company
- Personal Liability Company
- (Pty) Limited
- Non-Profit Company
- State Owned Company

[TICK APPLICABLE BOX]

4.6. I, the undersigned, who is duly authorised to do so on behalf of the company/firm, certify that the points claimed, based on the specific goals as advised in the tender, qualifies the company/firm for the preference(s) shown and I acknowledge that:

- i) The information furnished is true and correct.
- ii) The preference points claimed are in accordance with the General Conditions as indicated in paragraph 1 of this form;
- iii) In the event of a contract being awarded as a result of points claimed as shown in paragraphs 1.4 and 4.2, the contractor may be required to furnish documentary proof to the satisfaction of the organ of state that the claims are correct;
- iv) If the specific goals have been claimed or obtained on a fraudulent basis or any of the conditions of contract have not been fulfilled, the organ of state may, in addition to any other remedy it may have –
 - (a) disqualify the person from the tendering process;
 - (b) recover costs, losses or damages it has incurred or suffered as a result of that person's conduct;
 - (c) cancel the contract and claim any damages which it has suffered as a result of having to make less favorable arrangements due to such cancellation;
 - (d) recommend that the tenderer or contractor, its shareholders and directors, or only the shareholders and directors who acted on a fraudulent basis, be restricted from obtaining business from any organ of state for a period not exceeding 10 years, after the *audi alteram partem* (hear the other side) rule has been applied; and
 - (e) forward the matter for criminal prosecution, if deemed necessary.

BIDDER:

DR. JSMLM:

Initial: Authorized signatory/ies:
.....

1.

Initial: DR. JSMLM

26

2.

Witness:



.....
SIGNATURE(S) OF TENDERER(S)

SURNAME AND NAME:

DATE:

ADDRESS:

.....

.....

.....

Points will be awarded to the tenderer for attaining the B-BBEE status level of contributor in accordance with the table below.

B-BBEE Status Level of Contributor	Number of points (90/10)
1	10
2	9
3	8
4	5
5	4
6	3
7	2
8	1
Non-compliant contributor	0

B-BBEE Status Level of Contributor	Number of points (80/20)
1	10
2	9
3	8
4	7
5	6
6	5
7	3
8	2
Non-compliant contributor	0

In the event of a Joint Venture (JV) Tender:

A Joint venture will qualify for points for their B-BBEE status level as an unincorporated entity, provided that the entity submits their consolidated B-BBEE scorecard as if they were a group structure and that such a consolidated B-BBEE scorecard is prepared for every separate tender.

BIDDER:

DR. JSMLM:

Initial: Authorized signatory/ies:

1.

Initial: DR. JSMLM

2.

Witness:



PLEASE REMEMBER:

- **TO ATTACH A VALID TAX CLEARANCE PIN**
- **IN CASE OF A JOINT VENTURE, THE VALID TAX CLEARANCE PIN OF EACH PARTNER, THIS MUST BE SUBMITTED WITH THE BID DOCUMENT**

F.3.12 Insurance provided by the employer

If requested by the proposed successful tenderer, submit for the tenderer's information the policies and / or certificates of insurance which the conditions of contract identified in the contract data, require the employer to provide.

F.3.13 Acceptance of tender offer

F.3.13.1 Accept tender offer only if the tenderer complies with the legal requirements stated in the Tender Data.

F.3.13.2 Notify the successful tenderer of the employer's acceptance of his tender offer by completing and returning one copy of the form of offer and acceptance before the expiry of the validity period stated in the tender data, or agreed additional period. Providing the form of offer and acceptance does not contain any qualifying statements, it will constitute the formation of a contract between the employer and the successful tenderer as described in the form of offer and acceptance.

F.3.14 Notice to unsuccessful tenderers

After the successful tenderer has acknowledged the employer's notice Of acceptance, notify other tenderers that their tender offers have not been accepted.

F.3.15. Prepare contract documents

If necessary, revise documents that shall form part of the contract and that were issued by the employer as part of the tender documents to take account of:

- a) addenda issued during the tender period,
- b) inclusion of some of the returnable documents,
- c) other revisions agreed between the employer and the successful tenderer, and
- d) the schedule of deviations attached to the form of offer and acceptance, if any.

F.3.16 Issue final contract

Prepare and issue the final draft of contract documents to the successful tenderer for acceptance as soon as possible after the date of the employer's signing of the form of Offer and acceptance (including the schedule of deviations, if any). Only those documents that the conditions of tender require the tenderer to submit, after acceptance by the employer, shall be included.

F.3.17 Complete adjudicator's contract

Unless alternative arrangements have been agreed or otherwise provided for in the contract, arrange for both parties to complete formalities for appointing the selected adjudicator at the same time as the main contract is signed.

BIDDER:

DR. JSMLM:

Initial: Authorized signatory/ies:

1.

Initial: DR. JSMLM

.....

2.

Witness:



F.3.18 Provide copies of the contracts

Provide to the successful tenderer the number of copies stated in the Tender Data of the signed copy of the contract as soon as possible after completion and signing of the form of offer and acceptance.

BIDDER:

DR. JSMLM:

Initial: Authorized signatory/ies:
.....

1.

Initial: DR. JSMLM

29

2

Witness:



DR. JS MOROKA LOCAL MUNICIPALITY

DEPARTMENT NAME: *TECHNICAL SERVICES*

CONTRACT NO: **JSM R02/26-27/W27**

FOR THE **CONSTRUCTION OF KATJIBANE BUS AND TAXI ROUTE PHASE-5**

PART T2	LIST OF RETURNABLE DOCUMENTS	PAGE(S)
<i>The bidder must complete the following returnable documents.</i>		
T2.1	RETURNABLE SCHEDULES REQUIRED FOR BID EVALUATION PURPOSES	30
T2.2	OTHER DOCUMENTS REQUIRED FOR BID EVALUATION PURPOSES.....	45
T2.3	RETURNABLE SCHEDULES THAT WILL BE INCORPORATED IN THE CONTRACT	64

NOTE:

Although the documents under Part T2 is headed "Returnable Documents" in line with the CIDB model, these are not the only documents to be returned together with the bid. **All** the documents indicated on Part T1, must be completed and signed where applicable and submitted as a **complete set of documents**.

BIDDER:

Initial: Authorized signatory/ies:
.....

DR. JSMLM:

1.
2

Initial: DR. JSMLM

30

Witness:



T2.1 RETURNABLE SCHEDULES REQUIRED FOR BID EVALUATION PURPOSES

CONTENTS	PAGE(S)
PART T2 LIST OF RETURNABLE DOCUMENTS	
<i>The bidder must complete the following returnable documents.</i>	
FORM 2.1.1 SCHEDULE OF EQUIPMENTS REQUIRED FOR THE CONTRACT	31
FORM 2.1.2: SIZE OF ENTERPRISE AND CURRENT WORKLOAD.....	32
FORM 2.1.3: STAFFING PROFILE.....	33
FORM 2.1.4: PROPOSED KEY PERSONNEL.....	34
FORM 2.1.5: SCHEDULE OF PREVIOUS WORK CARRIED OUT BY BIDDER.....	35
FORM 2.1.6: FINANCIAL ABILITY TO EXECUTE THE PROJECT	36
FORM 2.1.7: AUTHORITY FOR SIGNATORY	37
FORM 2.1.8: SCHEDULE OF PROPOSED SUB CONTRACTORS	39
FORM 2.1.9: FINANCIAL REFERENCES (not required if CIDB grading applies).....	40
FORM 2.1.10 DETAILS OF ALTERNATIVE BIDS SUBMITTED	42
FORM 2.1.11 AMENDMENTS & QUALIFICATIONS BY BIDDER.....	43
FORM 2.1.12 LABOUR-ENHANCED METHODS: PROPOSED PLANNED ACTIONS OF BIDDER RESULTING IN DEVIATIONS FROM SPECIFIED WORK.....	44

BIDDER:	DR. JSMLM:	
Initial: Authorized signatory/ies:	1.	Initial: DR. JSMLM
2		
Witness:		



FORM 2.1.1 SCHEDULE OF EQUIPMENTS REQUIRED FOR THE CONTRACT

The Bidder shall state below what Equipments will be available for the work should he be awarded the Contract.

DESCRIPTION, SIZE, CAPACITY	NUMBER

BIDDER:

DR. JSMLM:

Initial: Authorized signatory/ies:
.....

1.

Initial: DR. JSMLM

2

Witness:



FORM 2.1.2

SIZE OF ENTERPRISE AND CURRENT WORKLOAD

What was your turnover in the previous financial year? R _____

What is the estimated turnover for your current financial year? R _____

Physical facilities:

Provide information on offices, factories, yards and warehouses occupied by your enterprise (attach details if the space provided is not enough)

Description	Address	Area (m ²)

List your current contracts and obligations:

Description	Value (R)	Start date	Duration	Expected completed date

Do you have the capacity to supply the goods and services described in this bid, should the contract be awarded to you?

BIDDER:

DR. JSMLM:

Initial: Authorized signatory/ies:

1.

Initial: DR. JSMLM

2

Witness:



FORM 2.1.4 PROPOSED KEY PERSONNEL

The Bidder shall list below the key personnel (including first nominee and the second-choice alternate), whom he proposes to employ on the project should his Bid be accepted, both at his headquarters and on the Site, to direct and for the execution of the work, together with their qualifications, experience, positions held and their nationalities.

DESIGNATION	NAME OF	NATIONALITY:	SUMMARY OF		HDI Status Yes/No	NQF 7 Certified Yes/No
	(i) NOMINEE (ii) ALTERNATE		QUALIFICA-TIONS	EXPERIENCE AND PRESENT OCCUPATION		
<u>HEADQUARTERS</u> Partner/director						
Project Manager						
Other key staff (give designation)						
<u>PROJECT MONITORING</u> Site(s) Supervisors						
Other key staff (give designation)						

BIDDER:

DR. JSMLM:

Initial: Authorized signatory/ies:

1.

Initial: DR. JSMLM

2

Witness:



FORM 2.1.5 SCHEDULE OF PREVIOUS WORK CARRIED OUT BY BIDDER

Provide the following information on **relevant previous experience**. Indicate comparable projects of similar or larger size. This information is material to the award of the Contract.

No points will be awarded if reference cannot be reached or if it refuses to supply information. Give at least two (2) names and telephone numbers and e-mail address per reference.

EMPLOYER (Name, tel no and fax no)	CONSULTING ENGINEER (Name, tel no and fax no)	NATURE OF WORK CARRIED OUT PREVIOUSLY	VALUE OF WORK	YEAR OF COMPLETION

BIDDER:

DR. JSMLM:

Initial: Authorized signatory/ies:
.....

1.

Initial: DR. JSMLM

2

Witness:



FORM 2.1.6 FINANCIAL ABILITY TO EXECUTE THE PROJECT

Provide details on the surety you will provide if the bid is awarded to you

AMOUNT

Which of the following institutions will provide surety?

- Bank registered in terms of the Bank Act 1990 (Act 94 of 1990): _____
- Insurance Company registered in terms of the Short Term Insurance Act 1998 (Act 53 of 1998): _____
- Cash: _____

Provide the estimated cash flow on the project in terms of submissions of payment certificates or payment schedules to the Employer

Month no	Amount (VAT included)			
	a Received	b Payments made	a – b Net cash flow	Cumulative cash flow
1			d	j=d
2			e	j+e=k
3			f	k+f=l
4			g	l+g=m
5			h	m+h=n
6			Etc.	Etc.
7				
8				
Maximum negative cash flow: Take the largest negative number in the last column and write it in here → → → → → →				

Notes:

- (i) Value added tax to be included in all amounts
- (ii) Assume payment of certificates within 30 days of approval of certificate

From what sources will you fund the above amount (e.g. Funds internally available, bank overdraft, loan, etc)

BIDDER:

DR. JSMLM:

Initial: Authorized signatory/ies:

1.

Initial: DR. JSMLM

2

Witness:



FORM 2.1.7 AUTHORITY FOR SIGNATORY

All signatories, including sole proprietors, shall confirm their authority by **attaching to the last page of this bid** a duly signed and **dated original or certified copy** of the relevant resolution of their members or their board of directors, as the case may be on the company letterhead.

An *example* for “COMPANIES / PARTNERSHIPS / CLOSE CORPORATIONS is shown below:

"By resolution of the board of directors passed on 12 February 2010, Mr M W Thomson has been duly authorised to sign all documents in connection with the Bid for Contract number 000/2010 and any Contract, which may arise there from on behalf of the Bidding Entity, namely, NMP (PTY) LTD"

SIGNED ON BEHALF OF THE BIDDING ENTITY: B.J. JONES
 IN HIS CAPACITY AS: DIRECTOR / PARTNER / MEMBER
 DATE: 12 February 2010
 AUTHORISED PERSON'S SIGNATURE: M W Thomson
 AS WITNESS: 1. M.A Ntuli

An *example* for “JOINT VENTURES” is shown below:

We, the undersigned are submitting this bid offer in Joint Venture and hereby authorize Mr. B. BROOK, authorised signatory of the company “ABCD (PTY) LTD”, acting in the capacity of lead partner, to sign all documents in connection with the bid for Contract number 000/2010 and any contract resulting from it on our behalf.

NAME OF FIRM	ADDRESS	DULY AUTHORIZED SIGNATORY
(Lead partner, i.e. <u>“ABCD (PTY) LTD”</u>)	<u>P.O. Box 111 Springs 1560</u>	Signature : Name : Designation :
<u>Name of 2nd Company</u>	<u>Address of 2nd Company</u>	Signature : Name : Designation :
<u>Name of 3rd Company</u>	<u>Address of 3rd Company</u>	Signature : Name : Designation :

BIDDER:

DR. JSMLM:

Initial: Authorized signatory/ies:

1.

Initial: DR. JSMLM

2

Witness:



An **example** for “SOLE PROPRIETOR” is shown below:

“I hereby certify that I’m the sole proprietor of the Bidding Entity, namely, “MACADOO” and therefore duly authorised to sign the bidding documents”

SIGNATURE OF SOLE PROPRIETOR: M W Thomson

IN HIS CAPACITY AS: SOLE PROPRIETOR

DATE: 12 February 2010

AUTHORISED PERSON’S SIGNATURE: M W Thomson

AS WITNESS: 1. M A Ntuli

BIDDER:

DR. JSMLM:

Initial: Authorized signatory/ies:
.....

1.

Initial: DR. JSMLM

2

Witness:



FORM 2.1.9 FINANCIAL REFERENCES

FINANCIAL STATEMENTS

I/We agree, if required, to furnish an audited copy of the latest set of financial statements together with my/our Directors' and Auditors' report.

DETAILS OF BIDDING ENTITY'S BANK

If the bidder is a Joint Venture or partnership, the information requested below is required for each member / partner.

I/We hereby authorise the Employer/Engineer to approach all or any of the following banks for the purposes of obtaining a financial reference:

DESCRIPTION OF BANK DETAIL	BANK DETAILS APPLICABLE TO BIDDER
Name of bank	
Contact person	
Branch name	
Branch code	
Street address	
Postal address	
Telephone number	()
Fax number	()
Account number	
Type of account, (i.e. cheque account)	

BIDDER:

DR. JSMLM:

Initial: Authorized signatory/ies:

1.

Initial: DR. JSMLM

2

Witness:



BIDDER'S TAX DETAILS

Bidder's VAT vendor registration number:

Bidder's SARS tax reference number:

DESCRIPTION OF BANK DETAIL	BANK DETAILS APPLICABLE TO BIDDER
Name of bank	
Contact person	
Branch name	
Branch code	
Street address	
Postal address	
Telephone number	()
Fax number	()
Account number	
Type of account, (i.e. cheque account)	

BIDDER'S TAX DETAILS

Bidder's VAT vendor registration number:

Bidder's SARS tax reference number:

BIDDER:

DR. JSMLM:

Initial: Authorized signatory/ies:

1.

Initial: DR. JSMLM

2

Witness:



FORM 2.1.10 DETAILS OF ALTERNATIVE BIDS SUBMITTED

See condition of bid.

DESCRIPTION

BIDDER:

DR. JSMLM:

Initial: Authorized signatory/ies:
.....

1.

Initial: DR. JSMLM

2

Witness:



FORM 2.1.11 AMENDMENTS AND QUALIFICATIONS BY BIDDER

See condition of bid

PAGE	DESCRIPTION

BIDDER:

DR. JSMLM:

Initial: Authorized signatory/ies:
.....

1.

Initial: DR. JSMLM

2

Witness:



FORM 2.1.12 LABOUR-ENHANCED METHODS: PROPOSED PLANNED ACTIONS OF BIDDER RESULTING IN DEVIATIONS FROM SPECIFIED WORK

ACTIVITY OR PAY ITEM	DESCRIPTION OF PLANNED ACTION RESULTING IN DEVIATION FROM SPECIFIED WORK

Compliance with Employment Equity Act 55 of 1998

Attach a valid certificate from the Department of Labour, or a declaration (refer to “Form 2.3.5 – Specific goals”) by the designated employer, that the employer complies with the relevant chapters of the Employment Equity Act.

Definitions in terms of the last mentioned Act.

“designated employer” means-

- a) an employer who employs 50 or more employees;
- b) an employer who employs fewer than 50 employees, but has a total annual turnover that is equal to or above the applicable annual turnover of a small business in terms of Schedule 4 to this Act.”

“Schedule 4”

TURNOVER THRESHOLD APPLICABLE TO DESIGNATED EMPLOYERS

Sector or sub sector in accordance with the Standard Industrial Classification	Total annual turnover
Agriculture	R 2,00 m
Mining and Quarrying	R 7,50 m
Manufacturing	R 10,00 m
Electricity, Gas and Water	R 10,00 m
Construction	R 5,00 m
Retail and Motor Trade and Repair Services	R 15,00 m
Wholesale Trade, Commercial Agents and Allied Services	R 25,00 m
Catering, Accommodation and other Trade	R 5,00 m
Transport, Storage and Communications	R 10,00 m
Finance and Business Services	R 10,00 m
Community, Social and Personal Services	R 5,00 m

BIDDER:

DR. JSMLM:

Initial: Authorized signatory/ies:

1.

Initial: DR. JSMLM

2

Witness:



DR. JS MOROKA LOCAL MUNICIPALITY

DEPARTMENT NAME: *TECHNICAL SERVICES*

CONTRACT NO: JSM R02/26-27/W27

FOR THE **CONSTRUCTION OF KATJIBANE BUS AND TAXI ROUTE PHASE-5**

T2.2 OTHER DOCUMENTS REQUIRED FOR BID EVALUATION PURPOSES

CONTENTS	PAGE(S)
FORM 2.2.1: CERTIFICATE OF BIDDER'S ATTENDANCE AT THE SITE/ CLARIFICATION MEETING	46-47
FORM 2.2.2: TAX CLEARANCE PIN OR COPY	48
FORM 2.2.3 PROOF OF REGISTRATION WITH SECURITY INDUSTRY REGULATION AUTHORITY	49
FORM 2.2.4 DECLARATION	50
FORM 2.2.5 DECLARATION OF INTEREST	51
FORM 2.2.6 DECLARATION FOR PROCUREMENT ABOVE R10 MILLION	52
FORM 2.2.7 DECLARATION CERTIFICATE FOR LOCAL PRODUCTION AND CONTENT FOR DESIGNATED SECTORS	53

BIDDER:

DR. JSMLM:

Initial: Authorized signatory/ies:
.....

1.

Initial: DR. JSMLM

46

2

Witness:



FORM 2.2.1 COMPULSORY SITE INSPECTIONS / INFORMATION / CLARIFICATION MEETINGS

Where Compulsory Site Inspections and Compulsory Information, Briefing or Clarification Meetings are to be held, it shall be subject to the following conditions:

1. Necessity for Compulsory Site Inspection and Compulsory Information / Briefing / Clarification Meetings

Compulsory Inspections / Meetings must only be held where the nature of the contract is such that it requires either an inspection of a site or a briefing session. The Bid Specification Committee should indicate to the Bid Office that such a compulsory inspection or briefing is regarded as a necessity.

2. Attendance Register

An attendance register of potential bidders and the firms they represent shall be kept and signed by attendees. A copy of such Attendance Register shall immediately after the inspection/briefing be sent to the Bid Office.

3. Confirmation Notes of Inspection/Briefing Sessions

Confirmation Notes of the Compulsory Inspection or Briefing Session shall be held by or on behalf of the contact person of the Department for whom the Bid is being advertised. A copy of the notes shall be sent to each firm that was represented at the inspection/meeting as soon as possible after the inspection or meeting and before the closing date of the bid. A copy of the notes shall also be sent to the Bid Office. The relevant Department will ensure that the notes are submitted to the Bid Evaluation Committee and to the Bid Adjudication Committee.

4. Bid Documents

The bid documentation shall clearly state that where the inspection of a site or the attendance of a briefing session is compulsory, non-attendance thereof will lead to the disqualification of the bidder in question. The bid documentation shall further clearly state that if bid documents are obtained **after** the compulsory briefing session or site inspection, it will only be made available to firms that were represented at the meeting. The mere fact that a firm that was not represented at a compulsory site inspection/meeting, but nevertheless submitted to the municipality a set of bidding documents, should not be construed as creating any expectations that a bid will be considered by the Municipality.

BIDDER:

DR. JSMLM:

Initial: Authorized signatory/ies:
.....

1.

Initial: DR. JSMLM

2

Witness:



FORM 2.2.1 CERTIFICATE OF BIDDER'S ATTENDANCE AT THE COMPULSORY SITE/CLARIFICATION MEETING

This is to certify that I, **(NAME IN PRINT)**,
representative of (Bidder)
.....
of (address)
.....
.....
Telephone number
Fax number
visited and inspected the Site / Attended Clarification Meeting on (date)
in the company of (Engineer/Engineer's Representative)

SIGNATURE OF BIDDER'S REPRESENTATIVE:

DR JS MOROKA LOCAL MUNICIPALITY
OFFICIAL STAMP WITH DATE



FORM 2.2.2 TAX CLEARANCE PIN

A VALID TAX CLEARANCE PIN OR COPY THEREOF, OBTAINED FROM SARS TO BE SUBMITTED WITH BID DOCUMENTS.

BIDDER:

DR. JSMLM:

Initial: Authorized signatory/ies:
.....

1.

Initial: DR. JSMLM

2

Witness:



FORM 2.2.3 PROOF OF REGISTRATION WITH CONSTRUCTION INDUSTRY DEVELOPMENT BOARD

The bidder is to affix to this page either:

- Written proof of registration with the CIDB as a Category **5CE OR HIGHER**.

Or

- Written proof of application to the CIDB for registration as a contractor in the category listed above.

Note:

1. Failure to affix such documentation as prescribed to this page shall result in this bid not being further considered for the award of the contract.
2. Should this bid be considered for award of the contract, based on proof of submission of application for registration in the appropriate category with the CIDB, and should proof of such subsequent registration not be forthcoming to the employer before the end of business, at the last working day, prior to evaluation by the Tender Evaluation Committee of the contract, then this bid will no longer be considered for the award of the contract.

BIDDER:

DR. JSMLM:

Initial: Authorized signatory/ies:
.....

1.

Initial: DR. JSMLM

2

Witness:



FORM 2.2.4 DECLARATION:

I/We, the undersigned:

- (a) bid to supply and deliver to the DR. JS Moroka Local Municipality [hereafter "DR. JSMLM"] all or any of the supplies and to render all or any of the articles, goods, materials, services or the like described both in this and the other Schedules to this Contract;
- (b) agree that we will be bound by the specifications, prices, terms and conditions stipulated in those Schedules attached to this bid document, regarding delivery and execution;
- (c) further agree to be bound by those conditions, set out in, "PARTS T1; T2; C1; C2; C3 and C4", attached hereto, should this bid be accepted in whole or in part;
- (d) confirm that this bid may only be accepted by the DR. JSMLM by way of a duly authorised Letter of Acceptance;
- (e) declare that we are fully acquainted with the Bid document and Schedules, and the contents thereof and that we have signed the Bill of Quantities and completed the Returnable Schedules and declarations, attached hereto;
- (f) declare that all amendments to the bid document have been initialled by the relevant authorised person and that the document constitutes a proper contract between the DR. JSMLM and the undersigned;
- (g) certify that the item/s mentioned in the bid document, qualifies/qualify for the preference(s) shown.;
- (h) acknowledge that the information furnished is true and correct;
- (i) accept that in the event of the contract being awarded as a result of preference claimed in this bid document, I may be required to furnish documentary proof to the satisfaction of the DR. JSMLM that the claims are correct. If the claims are found to be inflated, the DR. JSMLM may, in addition to any other remedy it may have, recover from me all cost, losses or damages incurred or sustained by the DR. JSMLM as a result of the award of the contract and/or cancel the contract and claim any damages which the DR. JSMLM may suffer by having to make less favourable arrangements after such cancellation;
- (j) declare that no municipal rates and taxes or municipal service charges owed by the bidder or any of its directors to the municipality, or to any other municipality or municipal entity, are in arrears for more than three (3) months; and
- (k) declare that I have not failed to perform satisfactorily during the last five (5) years on a previous contract with the Municipality, Municipal entity or any other organ of state, after written notice was given to me that my performance was unsatisfactory.

Signed at this day of

Authorised Signature: _____

Name of Bidding Entity: _____

Date: _____

As witness: 1. _____

BIDDER:	DR. JSMLM:	
Initial: Authorized signatory/ies:	1.	Initial: DR. JSMLM
	2.	
Witness:		



FORM 2.2.5 DECLARATION OF INTEREST

1. No bid will be accepted from persons in the service of the state*.
2. Any person, having a kinship with persons in the service of the state, including a blood relationship, may make an offer or offers in terms of this invitation to bid. In view of possible allegations of favouritism, should the resulting bid, or part thereof, be awarded to persons connected with or related to persons in service of the state, it is required that the bidder or their authorised representative declare their position in relation to the evaluating/adjudicating authority and/or take an oath declaring his/her interest.

3 In order to give effect to the above, the following questionnaire must be completed and submitted with the bid.

3.1 Full Name:

3.2 Identity Number:

3.3 Company Registration Number:

3.4 Tax Reference Number:

3.5 VAT Registration Number:

3.6 Are you presently in the service of the state*..... **YES / NO**

3.6.1 If so, furnish particulars.

.....

3.7 Have you been in the service of the state for the past twelve months? **YES / NO**

If so, furnish particulars.

.....

3.8 Do you, have any relationship (family, friend, other) with persons in the service of the state
 And who may be involved with the evaluation and or adjudication of this bid? **YES / NO**

3.8.1 If so, furnish particulars.

.....

* MSCM Regulations: "in the service of the state" means to be –

- (a) a member of –
 - (i) any municipal Council;
 - (ii) any provincial legislature; or
 - (iii) the national Assembly or the national Council of provinces;
- (b) a member of the board of directors of any municipal entity;
- (c) an official of any municipality or municipal entity;
- (d) an employee of any national or provincial department, national or provincial public entity or constitutional institution within the meaning of the Public Finance Management Act, 1999 (Act No.1 of 1999);
- (e) a member of the accounting authority of any national or provincial public entity; or
- (f) an employee of Parliament or a provincial legislature.

BIDDER:

DR. JSMLM:

Initial: Authorized signatory/ies:

1.

Initial: DR. JSMLM

2

Witness:



3.9 Are you, aware of any relationship (family, friend, other) between a bidder and any persons in the service of the state who may be involved with the evaluation and or adjudication of this bid? YES / NO

3.9.1 If so, furnish particulars

.....
.....

3.10 Are any of the company's directors, managers, principle shareholders or stakeholders in service of the state? YES / NO

3.10.1 If so, furnish particulars.

.....
.....

3.11 Are any spouse, child or parent of the company's directors, managers, principle shareholders or stakeholders in service of the state? YES / NO

3.11.1 If so, furnish particulars.

.....
.....

CERTIFICATION

I, THE UNDERSIGNED (NAME)

CERTIFY THAT THE INFORMATION FURNISHED ON THIS DECLARATION FORM IS CORRECT.

I ACCEPT THAT THE STATE MAY ACT AGAINST ME SHOULD THIS DECLARATION PROVE TO BE FALSE.

SHOULD THE INFORMATION REQUIRED ON THIS FORM NOT DULY BE SUPPLIED, THIS BID WILL BE REJECTED.

.....
Signature

.....
Date

.....
Position

.....
Name of Bidding Entity

BIDDER:

DR. JSMLM:

Initial: Authorized signatory/ies:
.....

1.

Initial: DR. JSMLM

2

Witness:



DR. JS MOROKA LOCAL MUNICIPALITY

DEPARTMENT NAME: *TECHNICAL SERVICES*

CONTRACT NO: *JSM R02/26-27/W27*

FOR THE **CONSTRUCTION OF KATJIBANE BUS AND TAXI ROUTE PHASE-5**

T2.3 RETURNABLE SCHEDULES THAT WILL BE INCORPORATED IN THE CONTRACT

CONTENTS	PAGE(S)
FORM 2.3.1 RECORD OF ADDENDA TO BID DOCUMENTS	65
FORM 2.3.2 CONDITIONS PERTAINING TO TARGETED PROCUREMENT.....	66

BIDDER:

DR. JSMLM:

Initial: Authorized signatory/ies:
.....

1.

Initial: DR. JSMLM

54

2

Witness:



FORM 2.3.1

RECORD OF ADDENDA TO BID DOCUMENTS

We confirm that the following communications received from the Procuring Department before the submission of this bid offer, amending the bid documents, have been taken into account in this bid offer:

	Date	Title or Details
1		Confirmatory notes of compulsory site/clarification meeting
2		
3		
4		
5		
6		
7		
8		

Attach additional pages if more space is required.

.....
 Signature Date

.....
 Position Name of Bidder

BIDDER:

DR. JSMLM:

Initial: Authorized signatory/ies:

1.

Initial: DR. JSMLM

2

Witness:



FORM 2.3.2 CONDITIONS PERTAINING TO TARGETED PROCUREMENT

- 2.3.2.1 PREAMBLE
- 2.3.2.2 DEFINITIONS
- 2.3.2.3 LEGISLATIVE BASE
- 2.3.2.4 SCOPE
- 2.3.2.5 PURPOSE
- 2.3.2.6 OBJECTIVES
- 2.3.2.7 GENERAL PRINCIPLES GOVERNING THE MUNICIPALITY IN ITS
INTERACTION WITH BIDDERS
- 2.3.2.8 ADJUDICATION OF BIDS
- 2.3.2.9 ADJUDICATION USING A POINT SYSTEM
- 2.3.2.10 IMPLEMENTATION FRAMEWORK
- 2.3.2.11 COMPLAINTS/DISQUALIFICATIONS
- 2.3.2.12 DISQUALIFICATIONS

BIDDER:

DR. JSMLM:

Initial: Authorized signatory/ies:
.....

1.

Initial: DR. JSMLM

2

Witness:



DR. JS MOROKA LOCAL MUNICIPALITY

BID DOCUMENT

2.3.3 CONDITIONS PERTAINING TO TARGETED PROCUREMENT

1. EVALUATION OF TENDERS

Evaluation Criteria

Municipal Supply Chain Management Policy will be used for evaluation of Prospective Service Provider as per the approved scoring system by the specification committee.

The evaluation will be done as per Preferential Procurement Regulations, 2022 issued in terms of section 5 of PPPFA, Act No. 5 of 2000 including any other amendments made thereafter.

The Construction Firm's tender responsiveness in relation to points is therefore summarized as follows:

Organizing and Staffing	25
Plant	15
Experience of Firm	40
Safety, Health, environmental, Risk and quality management plan	20
Sub-Total	100

A firm must obtain a minimum of 60 points out of the 100 points above to be considered for price and BBB-EE evaluation/The functionality points shall be distributed as follows below:

BIDDER:

DR. JSMLM:

Initial: Authorized signatory/ies:

1.

Initial: DR. JSMLM

2

Witness:



Project Manager / Contracts Manager (Maximum points obtainable 10; minimum 2)

Name:

Note: It must be noted that total points of **10** are obtainable. Points will be allocated for the highest academic qualification only. Failure to submit evidential documents is an elimination factor **and** a Zero point will be scored.

Evaluation Criteria	Minimum Required	Elimination Factor	Points obtainable	Points Claimed
Academic Qualifications	Diploma in Civil Engineering or equivalent NQF 6	Yes	4	
Academic Qualifications	NQF 7- Degree in Civil Engineering or Equivalent	No	5	
	Professional Registration (ECSA) PrEng/ Tech/ Technician	Yes	2	
Sub-total			7	
Experience of in similar projects		Elimination Factor		
Involvement in comparable Civil engineering projects	0	Yes	0	
	1 – 4	Yes	2	
	5 upwards	No	3	
Sub-total			3	
Total			10	

BIDDER:

DR. JSMLM:

Initial: Authorized signatory/ies:

1.

Initial: DR. JSMLM

58

2

Witness:



Site Agent: (Maximum Points obtainable 5, minimum 2)

Name:

valuation Criteria	Minimum Required	Elimination Factor	Points obtainable	Points Claimed
Academic Qualifications	NQF 6 Diploma in Civil Engineering or Equivalent	Yes	2	
Academic Qualifications	No formal Education in Construction	Yes	0	
Sub-total			2	
Years of experience in similar projects	0 – 4	Yes	0	
	5 – 9	No	2	
	10 and above	No	3	
Sub-total			3	
Total			5	

Note: Should the Site Agent be the same as Contractor Manager zero points will be allocated.

Site Foreman: (Maximum Points obtainable 5; minimum 2)

Name:

Evaluation Criteria	Minimum Required	Elimination Factor	Points obtainable	Points Claimed
Academic Qualifications (Note 10)	N6 in Civil Engineering or Equivalent	No	2	
Academic Qualifications	Matric	Yes	1	
Sub-total			2	
Years of experience after qualification	0 - 3	Yes	0	
	4 – 9	No	2	
	10 upwards	No	3	
Sub-total			3	
Total			5	

Note: Should the Site Foremen be the same Site Agent and Team leader zero points will be allocated

BIDDER: DR. JSMLM:

Initial: Authorized signatory/ies: 1.

Initial: DR. JSMLM

2

Witness:



Safety Officer: *(Maximum Points obtainable 5; minimum 2)*

Name:

Evaluation Criteria	Minimum Required	Elimination Factor	Points obtainable	Points Claimed
Academic Qualifications	Certificate in Occupational Health and Safety or Equivalent	Yes	2	
	Professional registration (SACPCMP) in OHS	Yes	1	
Sub-total			3	
Years of experience after qualification	0-3	Yes	0	
	4-9	No	1	
	10 upwards	No	2	
Sub-total			2	
Total			5	

Note: Should the Safety Officer be the same as Team leader, Site Agent, Site Foreman zero points will be allocated.

ORGANISING AND STAFFING/PERSONNEL		
PERSONNEL	TOTAL	SCORES
Construction Manager/Team Leader	10	
Site Agent	5	
Health and Safety Officer	5	
Site Foreman	5	
TOTAL	25	

BIDDER:

DR. JSMLM:

Initial: Authorized signatory/ies:

1.

Initial: DR. JSMLM

2.

Witness:



PLANT (Maximum Points obtainable 15)

It must be noted that a total points of **15** are obtainable by the Construction Firm in relation to the requirements as mentioned on the table below, failure to submit evidential supporting documents (Proof of ownership) is an eliminating factor. Letter of intent or quotation from the lessor must be attached.

Evaluation Criteria	Minimum Required	Elimination Factor	Points obtainable (Own)	Points obtainable (leased)	Points Claimed
Firm's plant and equipment – Note: proof of ownership of the firm's equipment must be attached and failure to do so will result in forfeiting the plant points	Excavator x1	Yes	3	1.5	
	Grader	Yes	3	1.5	
	Roller	Yes	3	1.5	
	Water Tanker	Yes	3	1.5	
	TLB	Yes	2	1	
	Bakkie	Yes	1	0.5	
Sub-total			15	7.5	
Total			15	7.5	

BIDDER:

DR. JSMLM:

Initial: Authorized signatory/ies:

1.

Initial: DR. JSMLM

61

2

Witness:



Safety. Health. Risk. Environmental and quality management plan

It must be noted that total points of **20** are obtainable in construction firm in relation to the requirement as mentioned on the table below, failure to submit evidential documents is an elimination factor **and** a Zero point will be scored.

Evaluation Criteria	Minimum Required	Elimination Factor	Points Obtainable	Points Claimed
	Health and Safety Plan	Yes	5	
	Baseline Risk Assessment	Yes	5	
	Environment Management Plan	Yes	5	
	Quality Management Plan	Yes	5	
Sub-total			20	
Total			20	

BIDDER:

DR. JSMLM:

Initial: Authorized signatory/ies:
.....

1.

Initial: DR. JSMLM

62

2

Witness:



EXPERIENCE OF FIRM (Maximum Points obtainable 40)

Note: Company's previous completed projects

It must be noted that the experience of the firm carries a maximum of **40 points** as indicated in the table below. If proof of testimonials and appointment letters, in reference to Form E is not provided, then the bidder shall obtain zero point on the experience of the firm.

Provide proof of the company's previous completed projects which is in the form appointment letters and completion certificates. Verifiable references (**appointment letters, Reference letters and completion certificates**) with contact details must be attached.

Similar projects are for Roads and Stormwater Projects. (including vat)-(scope must include Earthworks, Stone pitching, Kerbing & Paving)

Evaluation Criteria	Evaluation Criteria	Elimination Factor	Points obtainable	Points Claimed
Company experience in terms of projects of similar scope completed (Max 4 projects) Undertaken in the last 10 years. Bidder must attach appointment letter and completion certificate.	Project of similar scope with minimum value R3m – R5m 5points each	Yes	20(Max)	
	Project similar scope with minimum value of R5m – 8m 8points each	Yes	30(Max)	
	Project of similar scope with minimum value of R8m- 10points each	Yes	40(Max)	
Sub-Total			40	
TOTAL			40	

TOTAL SCORE _____ /100

BIDDER:

DR. JSMLM:

Initial: Authorized signatory/ies:

1.

Initial: DR. JSMLM

2

Witness:



The score points are distributed as follows:

10 – POINTS (FOR PRICE):

ITEM No.	DESCRIPTION	ALLOCATED POINTS
1.	Price Competitiveness	80

In relation to Tendered Price, the points allocated to the Tender Price will be calculated using the following formula:

$$N_p = \frac{80 * [1 - (T_s - T_m)]}{T_m}$$

Where: **N_p** = number of tender adjudication points awarded in relation to price
T_s = Tender Sum

20 – POINTS (FOR BBBEE):

B-BBEE Status Level of Contributor	Number of points (80/20)
1	10
2	9
3	8
4	7
5	6
6	5
7	4
8	3
Non-compliant contributor	0

In the event of a Joint Venture (JV) Tender:

A Joint venture will qualify for points for their B-BBEE status level as an unincorporated entity, provided that the entity submits their consolidated B-BBEE scorecard as if they were a group structure and that such a consolidated B-BBEE scorecard is prepared for every separate tender.

PLEASE REMEMBER:

- TO ATTACH A VALID TAX PIN
- IN CASE OF A JOINT VENTURE, THE VALID TAX PIN OF **EACH PARTNER**, THIS MUST BE SUBMITTED WITH THE BID DOCUMENT
- TO ATTACH A B-BBEE CERTIFICATE

BIDDER:

DR. JSMLM:

Initial: Authorized signatory/ies:

1.

Initial: DR. JSMLM

2

Witness:



DR JS MOROKA LOCAL MUNICIPALITY



CONTRACT NO: *JSM R02/26-27/W27: CONSTRUCTION OF KATJIBANE BUS AND TAXI ROUTE PHASE-5*

THE CONTRACT

Part C1: Agreements and Contract Data

- C1.1 Form of Offer and Acceptance
- C1.2 Contract Data
- C1.3 Form of Guarantee
- C1.4 Agreement in Terms of Occupational Health and Safety Act, 1993 (Act No 85 Of 1993)

Part C2: Pricing Data

- C2.1 Pricing Instructions
- C2.2 Bills of quantities

Part C3: Scope of Work

- C3 Scope of Work

Part C4: Site Information

- C4 Site Information

Part C5 : Additional Relevant Documents

- C5.1 Dr JS Moroka Local Municipality Supply Chain Management Policy.
- C5.2 The preferential procurement policy framework Act of No 5, 2000: preferential procurement regulations, 2022 including any other amendments made thereafter and including the following:
- C5.3 JSM health and safety specifications
- C5.4 Guidelines for the Implementation of Labour-Intensive Infrastructure projects under the Expanded Public Works Programme (EPWP)
- C5.5. Photo Record and site Locality
- C5.6. Tender Drawings
- C5.7 Name Board
- C5.8. Environmental Checklist/ Penalties

BIDDER:

DR. JSMLM:

Initial: Authorized signatory/ies:
.....

1.

Initial: DR. JSMLM

65

2

Witness:



DR JS MOROKA LOCAL MUNICIPALITY



**CONTRACT NO: . JSM R02/26-27/W27 : CONSTRUCTION OF KATJIBANE BUS AND TAXI ROUTE
PHASE-5**

C1 AGREEMENTS AND CONTRACT DATA

C1.1 Form of Offer and Acceptance

C1.2 Contract Data

C1.3 Form of Guarantee

C1.4 Agreement in Terms of Occupational Health and Safety Act, 1993 (Act No 85 Of 1993)

BIDDER:

DR. JSMLM:

Initial: Authorized signatory/ies:
.....

1.

Initial: DR. JSMLM

2

Witness:



C1.1 FORM OF OFFER AND ACCEPTANCE

C1.1 FORM OF OFFER AND ACCEPTANCE

**FORM OF OFFER AND ACCEPTANCE
(AGREEMENT)**

OFFER

The Employer, identified in the Acceptance signature block, has solicited offers to enter into a contract in respect of the following works: **CONSTRUCTION OF KATJIBANE BUS AND TAXI ROUTE PHASE-5**

The Bidder, identified in the Offer signature block below, has examined the documents listed in the Bid Data and addenda thereto as listed in the Bid Schedules, and by submitting this Offer has accepted the Conditions of Bid.

By the representative of the Bidder, deemed to be duly authorised, signing this apart of this Form of Offer and Acceptance, the Bidder offers to perform all of the obligations and liabilities of the Contractor under the Contract including compliance with all its terms and conditions according to their true intent and meaning for an amount to be determined in accordance with the Conditions of Contract identified in the Contract Data.

THE OFFERED TOTAL OF THE PRICES INCLUSIVE OF VALUE ADDED TAX IS

_____ Rand (in words);
 R _____ (in figures),

This Offer may be accepted by the Employer by signing the Acceptance part of this Form of Offer and Acceptance and returning one copy of this document to the Bidder before the end of the period of validity stated in the Bid Data, whereupon the Bidder becomes the party named as the Contractor in the Conditions of Contract identified in the Contract Data.

It is expressly agreed that no other matter whether in writing, oral communication or implied during the period between the issue of the Bid documents and the receipt by the Bidder of a completed signed copy of this Agreement shall have any meaning or effect in the contract between the parties arising from this Agreement.

FOR THE BIDDER:

Signature(s) _____

Name(s) _____

Capacity _____

 (Name and address of organization)

Name and signature of Witness _____

Date _____

BIDDER: _____ **DR. JSMLM:** _____

Initial: Authorized signatory/ies: **1.** **Initial:** DR. JSMLM 67

2

Witness:



ACCEPTANCE

By signing this part of this Form of Offer and Acceptance, the Employer identified below accepts the Bidder's Offer. In consideration thereof, the Employer shall pay the Contractor the amount due in accordance with the, Conditions of Contract identified in the Contract Data. Acceptance of the Bidder's Offer shall form an agreement, between the Employer and the Bidder upon the terms and conditions contained in this Agreement and in the, Contract that is the subject of this Agreement.

The terms of the contract, are contained in

Part C1	Agreements and Contract Data, (which includes this Agreement)
Part C2	Pricing Data
Part C3	Scope of Work
Part C4	Site Information

and drawings and documents or parts thereof, which may be incorporated by reference into Parts C1 to C4 above.

Deviations from and amendments to the documents listed in the Bid Data and any addenda thereto listed in the Bid Schedules as well as any changes to the terms of the Offer agreed by the Bidder and the Employer during this process of offer and acceptance, are contained in the Schedule of Deviations attached to and forming part of this Agreement. No amendments to or deviations from said documents are valid unless contained in this Schedule, which must be duly signed by the authorised representative(s) of both parties.

The Bidder shall within two weeks after receiving a completed copy of this Agreement, including the Schedule of Deviations (if any), contact the Employer's agent (whose details are given in the Contract Data) to arrange the delivery of any bonds, guarantees, proof of insurance and any other documentation to be provided in terms of the, Conditions of Contract identified in the Contract Data. Failure to fulfil any of these obligations in accordance with those terms shall constitute a repudiation of this Agreement.

Notwithstanding anything contained herein, this Agreement comes into effect on the date when the Bidder receives one fully completed original copy of this document, including the Schedule of Deviations (if any). Unless the Bidder (now Contractor) within five working days of the date of such receipt notifies the Employer in writing of any reason why he cannot accept the contents of this Agreement, this Agreement shall constitute a binding contract between the parties.

It is expressly agreed that no other matter whether in writing, oral communication or implied during the period between the issue of the Bid documents and the receipt by the Bidder of a completed signed copy of this Agreement shall have any meaning or effect in the contract between the parties arising from this Agreement.

FOR THE CLIENT:

Signature(s) _____
 Name(s) _____
 Capacity _____

DR. JS MOROKA LOCAL MUNICIPALITY
 (Name and address of organization)

Name and signature of witness _____

Date _____

BIDDER:

DR. JSMLM:

Initial: Authorized signatory/ies:

1.

Initial: DR. JSMLM

2

Witness:



SCHEDULE OF DEVIATIONS

Notes:

1. The extent of deviations from the bid documents issued by the Employer prior to the bid closing date is limited to those permitted in terms of the Conditions of Bid.
2. A Bidder's covering letter shall not be included in the final contract document. Should any matter in such, letter, which constitutes a deviation as aforesaid become the subject of agreements reached during the process of, offer and acceptance, the outcome of such agreement shall be recorded here.
3. Any other matter arising from the process of offer and acceptance either as a confirmation, clarification or change to the bid documents and which it is agreed by the Parties becomes an obligation of the contract shall also be recorded here.
4. Any change or addition to the bid documents arising from the above agreements and recorded here, shall also be incorporated into the final draft of the Contract.

1	Subject	_____
	Details	_____
2	Subject	_____
	Details	_____
3	Subject	_____
	Details	_____
4	Subject	_____
	Details	_____
5	Subject	_____
	Details	_____
6	Subject	_____
	Details	_____

By the duly authorised representatives signing this Schedule of Deviations, the Employer and the Bidder agree to and accept the foregoing Schedule of Deviations as the only deviations from and amendments to the documents listed in the Bid Data and addenda thereto as listed in the Bid Schedules, as well as any confirmation, clarification or change to the terms of the offer agreed by the Bidder and the Employer during this process of offer and acceptance.

It is expressly agreed that no other matter whether in writing, oral communication or implied during the period between the issue of the bid documents and the receipt by the Bidder of a completed signed copy of this Agreement shall have any meaning or effect in the contract between the parties arising from this Agreement.

BIDDER: _____ **DR. JSMLM:** _____

Initial: Authorized signatory/ies: **1.** **Initial:** DR. JSMLM 69

.....

2

Witness:



FOR THE BIDDER:

Signature(s) _____

Name(s) _____

Capacity _____

(Name and address of organisation)

Name and signature of Witness _____

Date _____

FOR THE EMPLOYER:

Signature(s) _____

Name(s) _____

Capacity _____

DR JS MOROKA LOCAL MUNICIPALITY
(Name and address of organisation)

Name and signature of Witness _____

Date _____

BIDDER:

DR. JSMLM:

Initial: Authorized signatory/ies:
.....

1.

Initial: DR. JSMLM

2

Witness:



C1.2 CONTRACT DATA

The General Conditions of Contract for Construction Work (GCC), 3rd Edition, 2015, published by the South African Institution of Civil Engineering, Private Bag X200, Halfway House, 1685, is applicable to this Contract and is obtainable from www.saice.org.za.

The following Contract Specific Data, Variations and Additional Clauses referring to the General Conditions of Contract for Construction Work (GCC), 3rd Edition, 2015, are applicable to this Contract.

Each item of data given below is cross-referenced to the clause in the Conditions of Contract to which it mainly applies.

PART 1: DATA PROVIDED BY THE EMPLOYER

CONTRACT SPECIFIC DATA	
Clause	Data
1.1.1.13	The Defects liability Period is 12 Months .
1.1.1.14	The time for achieving Practical Completion is 6 Months
1.1.1.15	The Name of the Employer is Dr. JS Moroka Local Municipality
1.1.1.26	The Pricing Strategy is Re-measurement Contract.
1.2.1.2	The address of the Employer is: Physical Address: 2601/3 Bongimfundo Street Postal Address : Private bag x 4012, Siyabuswa 0472 Tel No : (013) 973 9126/7 Fax No : (013) 973 9312/3
1.1.1.16	The Name of the Engineer is: Morula Engineers and Project Managers
1.2.1.2	The address of the Engineer is: MORULA CONSULTING ENGINEERS AND PROJECT MANAGERS Physical Address : 54A Dorpstreet, POLOKWANE, 0700 Postal Address : 2740, POLOKWANE, 0700 E-mail Address : admin@morulaconsulting.co.za / hulisani@morulaconsulting.co.za Tel : (087) 821 7033 / (086) 558 6446
*3.1.3	The Engineer shall obtain the specific approval of the Employer before executing any of his functions or duties according to the following Clauses of the General Condition of Contract : Clause Description 6.3 Variations

BIDDER:

DR. JSMLM:

Initial: Authorized signatory/ies:
.....

1.

Initial: DR. JSMLM

71

2

Witness:



CONTRACT SPECIFIC DATA	
Clause	Data
5.3.1	The documentation required before commencement with Works execution are : Health and Safety Plan (Refer to Clause 4.3) Initial program (Refer to Clause 5.6) Security (Refer to Clause 6.2) Insurance (Refer to Clause 8.6) All the Provisional Sums items are to be subjected to submission of three quotation and approval from the Municipality prior to any appointment.
5.3.2	The time to submit the documentation required before commencement with Works execution is 14 days.
5.4.2	The access and possession of Site shall not be exclusive to the Contractor but as set out in the Site Information.
5.8.1	The non-working days are Sundays. The special non-working days are : (i) South African public holidays; (ii) The year-end break commencing on 15 December and ending on 9 January.
5.12.2.2	Extension of time due to abnormal rainfall will be determined in accordance with the principles as set out in Annexure D to the Scope of Works: Extension of time due to abnormal rainfall.
5.13.1	The penalty for failing to complete the works is R5 000/day. Penalties will only be applied for a maximum of 2 months and termination process will take place thereafter.
5.16.3	The latent defect period is 10 years.
6.2.2	Additional retention in lieu of performance guarantee will not apply. The Contractor shall submit the selected security to the Employer before commencement with Works execution.
6.8.3	Price adjustments for variations in the costs of special materials are allowed.
6.10.1.5	The percentage advance on materials not yet built into the Permanent Works is 80%.
6.10.3	The limit of retention money is 10%.
6.10.4	The limit of contingencies shall be 2.5% and shall form part of the contract amount.
6.10.5	The Community Liaison Officer will be on site until the issue of Completion Certificate.
6.10.6	Labourers shall be paid using the recent labour rate determined by the SA Department of employment and labour.

BIDDER:

DR. JSMLM:

Initial: Authorized signatory/ies:
.....

1.

Initial: DR. JSMLM

72

2

Witness:



8.6.1.1.2	The value of Plant and materials supplied by the Employer to be included in the insurance sum is Nil.
8.6.1.1.3	The amount to cover professional fees for repairing damage and loss to be included in the insurance sum is R 250 000.00

CONTRACT SPECIFIC DATA	
Clause	Data
8.6.1.3	The limit of indemnity for liability insurance is R10 000 000.00.
10.5.3	The number of Adjudication Board Members to be appointed is one.
10.7.1	The determination of disputes shall be in line with the General Conditions of Contract for Construction Work (GCC), 3 rd Edition, 2015.

BIDDER:

DR. JSMLM:

Initial: Authorized signatory/ies:
.....

1.

Initial: DR. JSMLM

73

2

Witness:



PART 2: DATA PROVIDED BY THE CONTRACTOR

Clause	Data														
1.1.1.9	The name of the Contractor is :														
1.2.1.2	The address of the Contractor is : Physical address: _____ Postal address : _____ E-mail address : _____ Fax : _____														
6.2.1	<p>The security to be provided by the Contractor shall be one of the following:</p> <table border="1"> <thead> <tr> <th>Type of security <i>(Value Added Tax is excluded from the Contract Sum and the value of the Works for calculating the amount of the security)</i></th> <th>Contractor's choice. Indicate "Yes" or "No"</th> </tr> </thead> <tbody> <tr> <td>Cash deposit of 10% of the Contract Sum</td> <td>Not applicable</td> </tr> <tr> <td>Deductions of 10% security from payment claims/ Work done</td> <td>Not applicable</td> </tr> <tr> <td>Performance guarantee of 10 % of the Contract</td> <td></td> </tr> <tr> <td>Retention of 10% of the value of the Works.</td> <td>Not applicable</td> </tr> <tr> <td>Cash deposit of 5% of the Contract Sum plus retention of 5% of the value of the Works.</td> <td>Not applicable</td> </tr> <tr> <td>Performance guarantee of 5% of the Contract Sum plus</td> <td>Not applicable</td> </tr> </tbody> </table>	Type of security <i>(Value Added Tax is excluded from the Contract Sum and the value of the Works for calculating the amount of the security)</i>	Contractor's choice. Indicate "Yes" or "No"	Cash deposit of 10% of the Contract Sum	Not applicable	Deductions of 10% security from payment claims/ Work done	Not applicable	Performance guarantee of 10 % of the Contract		Retention of 10% of the value of the Works.	Not applicable	Cash deposit of 5% of the Contract Sum plus retention of 5% of the value of the Works.	Not applicable	Performance guarantee of 5% of the Contract Sum plus	Not applicable
Type of security <i>(Value Added Tax is excluded from the Contract Sum and the value of the Works for calculating the amount of the security)</i>	Contractor's choice. Indicate "Yes" or "No"														
Cash deposit of 10% of the Contract Sum	Not applicable														
Deductions of 10% security from payment claims/ Work done	Not applicable														
Performance guarantee of 10 % of the Contract															
Retention of 10% of the value of the Works.	Not applicable														
Cash deposit of 5% of the Contract Sum plus retention of 5% of the value of the Works.	Not applicable														
Performance guarantee of 5% of the Contract Sum plus	Not applicable														
6.5.1.2.3	The percentage allowance to cover overhead charges is _____														
6.8.3	<p>The variation in cost of special materials is :</p> <table border="1"> <thead> <tr> <th>Type of special material</th> <th>Unit</th> <th>Rate or price</th> </tr> </thead> <tbody> <tr> <td>_____</td> <td>_____</td> <td>_____</td> </tr> </tbody> </table>	Type of special material	Unit	Rate or price	_____	_____	_____								
Type of special material	Unit	Rate or price													
_____	_____	_____													

BIDDER:

DR. JSMLM:

Initial: Authorized signatory/ies:

1.

Initial: DR. JSMLM

74

2

Witness:



General Conditions of Contract for Construction Work (GCC), 3rd Edition, 2015

PRO FORMA

PERFORMANCE GUARANTEE

For use with the General Conditions of Contract for Construction Work (GCC), 3rd Edition, 2015.

GUARANTOR DETAILS AND DEFINITIONS

“Guarantor” means: _____

Physical address: _____

“Employer” means: _____

“Contractor” means: _____

“Engineer” means: _____

“Works” means: _____

“Site” means: _____

“Contract” means: The Agreement made in terms of the Form of Offer and Acceptance and such amendments or additions to the Contract as may be agreed in writing between the parties.

“Contract Sum” means: The accepted amount inclusive of tax of R _____

Amount in words: _____

“Guaranteed Sum” means: The maximum aggregate amount of R _____

Amount in words: _____

“Expiry Date” means: _____

CONTRACT DETAILS

Engineer issues: Interim Payment Certificates, Final Payment Certificate and the Certificate Completion of the Works as defined in the Contract.

BIDDER:

DR. JSMLM:

Initial: Authorized signatory/ies:
.....

1.

Initial: DR. JSMLM

75

2

Witness:



PERFORMANCE GUARANTEE

1. The Guarantor’s liability shall be limited to the amount of the Guaranteed Sum.
2. The Guarantor’s period of liability shall be from and including the date of issue of this Performance Guarantee and up to and including the Expiry Date or the date of issue by the Engineer of the Certificate of Completion of the Works or the date of payment in full of the Guaranteed Sum, whichever occurs first. The Engineer and/or the Employer shall advise the Guarantor in writing of the date on which the Certificate of Completion of the Works has been issued.
3. The Guarantor hereby acknowledges that:
 - 3.1 any reference in this Performance Guarantee to the Contract is made for the purpose of convenience and shall not be construed as any intention whatsoever to create an accessory obligation or any intention whatsoever to create a suretyship;
 - 3.2 its obligation under this Performance Guarantee is restricted to the payment of money.
4. Subject to the Guarantor’s maximum liability referred to in 1, the Guarantor hereby undertakes to pay the Employer the sum certified upon receipt of the documents identified in 4.1 to 4.3:
 - 4.1 A copy of a first written demand issued by the Employer to the Contractor stating that payment of a sum certified by the Engineer in an Interim or Final Payment Certificate has not been made in terms of the Contract and failing such payment within seven (7) calendar days, the Employer intends to call upon the Guarantor to make payment in terms of 4.2;
 - 4.2 A first written demand issued by the Employer to the Guarantor at the Guarantor’s physical address with a copy to the Contractor stating that a period of seven (7) days has elapsed since the first written demand in terms of 4.1 and the sum certified has still not been paid;
 - 4.3 A copy of the aforesaid payment certificate which entitles the Employer to receive payment in terms of the Contract of the sum certified in 4.
5. Subject to the Guarantor’s maximum liability referred to in 1, the Guarantor undertakes to pay to the Employer the Guaranteed Sum or the full outstanding balance upon receipt of a first written demand from the Employer to the Guarantor at the Guarantor’s physical address calling up this Performance Guarantee, such demand stating that:
 - 5.1 the Contract has been terminated due to the Contractor’s default and that this Performance Guarantee is called up in terms of 5; or
 - 5.2 a provisional or final sequestration or liquidation court order has been granted against the Contractor and that the Performance Guarantee is called up in terms of 5; and
 - 5.3 the aforesaid written demand is accompanied by a copy of the notice of termination and/or the provisional/final sequestration and/or the provisional liquidation court order.
6. It is recorded that the aggregate amount of payments required to be made by the Guarantor in terms of 4 and 5 shall not exceed the Guarantor’s maximum liability in terms of 1.
7. Where the Guarantor has made payment in terms of 5, the Employer shall upon the date of issue of the Final Payment Certificate submit an expense account to the Guarantor showing how all monies received in terms of this Performance Guarantee have been expended and shall refund to the Guarantor any resulting surplus. All monies refunded to the Guarantor in terms of this Performance Guarantee shall bear interest at the prime overdraft rate of the Employer’s bank compounded monthly and calculated from the date payment was made by the Guarantor to the Employer until the date of refund.
8. Payment by the Guarantor in terms of 4 or 5 shall be made within seven (7) calendar days upon receipt of the first written demand to the Guarantor.
9. Payment by the Guarantor in terms of 5 will only be made against the return of the original Performance Guarantee by the Employer.

BIDDER:

DR. JSMLM:

Initial: Authorized signatory/ies:
.....

1.

Initial: DR. JSMLM

76

2

Witness:



10. The Employer shall have the absolute right to arrange his affairs with the Contractor in any manner which the Employer may deem fit and the Guarantor shall not have the right to claim his release from this Performance Guarantee on account of any conduct alleged to be prejudicial to the Guarantor.
11. The Guarantor chooses the physical address as stated above for the service of all notices for all purposes in connection herewith.
12. This Performance Guarantee is neither negotiable nor transferable and shall expire in terms of 2, where after no claims will be considered by the Guarantor. The original of this Guarantee shall be returned to the Guarantor after it has expired.
13. This Performance Guarantee, with the required demand notices in terms of 4 or 5, shall be regarded as a liquid document for the purposes of obtaining a court order.
14. Where this Performance Guarantee is issued in the Republic of South Africa the Guarantor hereby consents in terms of Section 45 of the Magistrate's Courts Act No 32 of 1944, as amended, to the jurisdiction of the Magistrate's Court of any district having jurisdiction in terms of Section 28 of the said Act, notwithstanding that the amount of the claim may exceed the jurisdiction of the Magistrate's Court

Signed at : _____
 Date : _____
 Guarantor's signatory (1) _____
 Capacity _____
 Guarantor's signatory (2) _____
 Capacity _____
 Witness signatory (1) _____
 Witness signatory (2) _____



General Conditions of Contract for Construction Work (GCC), 3rd Edition, 2015

PRO FORMA

ADJUDICATION BOARD MEMBER AGREEMENT

Please note that words in italics within brackets are items which should be stated.

This Agreement is entered into between:

Adjudication Board Member: *(Name, physical address, postal address, e-mail address, fax number, telephone number and mobile number).*

Contractor: *(Name, physical address, postal address, e-mail address, fax number, telephone number and mobile number).*

Employer: *(Name, physical address, postal address, e-mail address, fax number, telephone number and mobile number).*

The Contractor and the Employer will hereinafter be collectively referred to as the Parties.

The Parties entered into a Contract for *(name of project)* which provides that a dispute under or in connection with the General Conditions of Contract for Construction Work (GCC), 3rd Edition, 2015, must be referred to *(ad-hoc adjudication/standing adjudication)*.

The undersigned natural person has been appointed to serve as Adjudication Board Member and together with the undersigned Parties agree as follows:

1. The Adjudication Board Member accepts to perform his duties in accordance with the terms of the Contract, the General Conditions of Contract for Construction Works Adjudication Board Rules and this Agreement.
2. The Adjudicator undertakes to remain independent and impartial of the Contractor, Employer and Engineer for the duration of the Adjudication Board proceedings.
3. The Adjudication Board Member agrees to serve for the duration of the Adjudication Board proceedings.
4. The Parties may at any time, without cause and with immediate effect, jointly terminate this Agreement.
5. Unless the Parties agree, the Adjudication Board Member shall not act as arbitrator or representative of either Party in any subsequent proceedings between the Parties under the Contract. No Party may call the Adjudication Board Member as a witness in any such subsequent proceedings.
6. The standing Adjudication Board's duties shall end upon the Adjudication Board Member(s) receiving notice from the Parties of their joint decision to disband the Adjudication Board.
7. The Adjudication Board Member shall be paid in respect of time spent upon or in connection with the adjudication including time spent traveling :
 - a. A monthly retainer of *(amount)* for *(number)* of months, and/or
 - b. A daily fee of *(amount)* based on a *(number)* hour day, and/or
 - c. A hourly fee of *(amount)*, and/or

<u>BIDDER:</u>		<u>DR. JSMLM:</u>
Initial: Authorized signatory/ies:	1.	Initial: DR. JSMLM

2

Witness:



d. A non-recurrent appointment fee of (*amount*) which shall be accounted for in the final sums payable.

8. The Adjudication Board Member's expenses incurred in adjudication work shall be reimbursed at cost.

Upon submission of an invoice for fees and expenses to the Parties, the (*Contractor/Employer**) shall pay the full amount within 28 days of receipt of the invoice and he shall be reimbursed by the other party by half the amount so that the fees and expenses are borne equally by the Parties. Latepayment of such invoice shall attract interest at prime plus 3 % points compounded monthly at the prime rate charged by the Adjudication Board Member's bank.

This Agreement is entered into by:

Contractor's signature: _____

Contractor's name: _____

Place: _____

Date: _____

Employer's signature : _____

Employer's name: _____

Place: _____

Date: _____

Adjudication Board Member's signature: _____

Adjudication Board Member's name: _____

Place: _____

Date: _____

** Delete the inapplicable party*

BIDDER:

DR. JSMLM:

Initial: Authorized signatory/ies:

1.

Initial: DR. JSMLM

2

Witness:



C1.4 AGREEMENT IN TERMS OF THE OCUPATIONAL HEALTH AND SAFETY ACT, 1993 (ACT NO 85 OF 1993)

THIS AGREEMENT made at _____
 on this the _____ day of _____ in the year _____

between **THE DR. JS MOROKA LOCAL MUNICIPALITY** (hereinafter called "the Employer") of the one part,

herein represented by

in his capacity as _____

and

_____ (Hereinafter called "the Mandatory") of the other part, herein represented by

_____ in his capacity as _____

WHEREAS the Employer is desirous that certain works be constructed, viz **CONTRACT NO:**

JSM R02/25-26/W27

and has accepted a Bid by the Mandatory for the construction, completion and maintenance of such Works and whereas the Employer and the Mandatory have agreed to certain arrangements and procedures to be followed in order to ensure compliance by the Mandatory with the provisions of the Occupational Health and Safety Act, 1993 (Act 85 of 1993);

NOW THEREFORE THIS AGREEMENT WITNESSETH AS FOLLOWS:

- 1 The Mandatory shall execute the work in accordance with the Contract Documents pertaining to this Contract.
- 2 This Agreement shall hold good from its Commencement Date, which shall be the date of a written notice from the Employer or Engineer requiring him to commence the execution of the Works, to either
 - (a) the date of the Final Approval Certificate issued in terms of Clause 5.16 of the General Conditions of Contract (hereinafter referred to as "the GCC"),
 - (b) the date of termination of the Contract in terms of Clauses 9 of the GCC.
- 3 The Mandatory declares himself to be conversant with the following:
 - (a) All the requirements, regulations and standards of the Occupational Health and Safety Act (Act 85 of 1993), hereinafter referred to as "The Act", together with its amendments and with special reference to the following Sections of The Act:
 - (i) Section 8 : General duties of employers to their employees;
 - (ii) Section 9 : General duties of employers and self-employed persons to persons other than employees;

BIDDER: _____ **DR. JSMLM:** _____
Initial: Authorized signatory/ies: **1.** **Initial:** DR. JSMLM

2

Witness:



- (iii) Section 37 : Acts or omissions by employees or mandataries, and
- (iv) Subsection 37(2) relating to the purpose and meaning of this Agreement.
- (b) The procedures and safety rules of the Employer as pertaining to the Mandatory and to all his subcontractors.
- 4 In addition to the requirements of Clause 33 of the GCC and all relevant requirements of the above-mentioned Volume 3, the Mandatory agrees to execute all the Works forming part of this Contract and to operate and utilise all machinery, plant and equipment in accordance with the Act.
- 5 The Mandatory is responsible for the compliance with the Act by all his subcontractors, whether or not selected and/or approved by the Employer.
- 6 The Mandatory warrants that all his and his subcontractors' workmen are covered in terms of the Compensation for Occupational Injuries and Diseases Act, 1993 which cover shall remain in force whilst any such workmen are present on site. A letter of good standing from the Compensation Commissioner to this effect must be produced to the Employer upon signature of the agreement.**
- 7 The Mandatory undertakes to ensure that he and/or subcontractors and/or their respective employers will at all times comply with the following conditions:
 - (a) The Mandatory shall assume the responsibility in terms of Section 16.1 of the Occupational Health and Safety Act. The Mandatory shall not delegate any duty in terms of Section 16.2 of this Act without the prior written approval of the Employer. If the Mandatory obtains such approval and delegates any duty in terms of section 16.2 a copy of such written delegation shall immediately be forwarded to the Employer.
 - (b) All incidents referred to in the Occupational Health and Safety Act shall be reported by the Mandatory to the Department of Labour as well as to the Employer. The Employer will further be provided with copies of all written documentation relating to any incident.
 - (c) The Employer hereby obtains an interest in the issue of any formal inquiry conducted in terms of section 32 of the Occupational Health and Safety Act into any incident involving the Mandatory and/or his employees and/or his subcontractors.

In witness thereof the parties hereto have set their signatures hereon in the presence of the subscribing witnesses:

SIGNED FOR AND ON BEHALF OF THE EMPLOYER:

WITNESS 1
NAME (IN CAPITALS)

SIGNED FOR AND ON BEHALF OF THE MANDATORY:

WITNESS 1
NAME (IN CAPITALS)

BIDDER: **DR. JSMLM:**
Initial: Authorized signatory/ies: **1.** **Initial:** DR. JSMLM

2
Witness:



CERTIFICATE OF AUTHORITY FOR SIGNATORY TO AGREEMENT IN TERMS OF OCCUPATIONAL HEALTH AND SAFETY ACT, 1993 (ACT NO 85 OF 1993)

The signatory for the company that is the Contractor in terms of the above-mentioned Contract and the Mandatory in terms of the above-mentioned Act shall confirm his or her authority thereto by attaching to this page a duly signed and dated copy of the relevant resolution of the Board of Directors.

An example is given below:

"By resolution of the Board of Directors passed at a meeting held on _____20.....,

Mr/Ms _____ whose signature

appears below, has been duly authorised to sign the AGREEMENT in terms of THE OCCUPATIONAL HEALTH AND SAFETY ACT, 1993 (ACT 85 of 1993) on behalf of _____

SIGNED ON BEHALF OF THE COMPANY :

IN HIS/HER CAPACITY AS :

DATE :

SIGNATURE OF SIGNATORY :

WITNESS 1

NAME (IN CAPITALS)

BIDDER:

DR. JSMLM:

Initial: Authorized signatory/ies:

1.

Initial: DR. JSMLM

2

Witness:



DR JS MOROKA LOCAL MUNICIPALITY



CONTRACT NO: *JSM R02/26-27/W27 : CONSTRUCTION OF KATJIBANE BUS AND TAXI ROUTE PHASE-5*

C2 PRICING DATA

C2.1 Pricing Instructions

C2.2 Bill of Quantities

BIDDER:

DR. JSMLM:

Initial: Authorized signatory/ies:
.....

1.

Initial: DR. JSMLM

2

Witness:



DR JS MOROKA LOCAL MUNICIPALITY



CONTRACT NO: *JSM R02/25-26/W27* : CONSTRUCTION OF KATJIBANE BUS AND TAXI ROUTE PHASE-5

C2.1 PRICING INSTRUCTIONS

1. The Tender Data the Scope of Work and the Drawings are to be read in conjunction with the Schedule of Quantities.
2.
 - a. The Schedule comprises items covering the Contractor's profit and costs of general liabilities and of the construction of temporary and permanent Works.
 - b. Although the Tenderer is at liberty to insert a rate of his own choosing for each item in the Schedule, his attention is drawn to the fact that the Contractor has the right, under various circumstances, to payment for additional works carried out and that the Engineer is obliged to base his assessment of the payment to be paid for such additional work on the rates inserted in the Schedule by the Contractor.
 - c. Clause 8 of each Standardized Specification and the measurement and payment clause of each Particular Specification, read together with the relevant clause of the Project Specification, set out what ancillary or associated activities are included in the rate for the operations specified.
3. Descriptions in the Schedule of Quantities are abbreviated. The schedule has been drawn up generally in accordance with the latest issue of "Civil Engineering Quantities". Should any requirement of the measurement and payment clause of the applicable Standardized Specification, or the Project Specification, or the Particular Specification(s) conflict with the terms of the Schedule or, when relevant "Civil Engineering Quantities", the requirement of the Standardized, Project or Particular Specification, as applicable, shall prevail.
4. Unless otherwise stated, items are measured net in accordance with the Drawings, and no allowance has been made for waste.
5. The prices and rates to be inserted in the Schedule of Quantities are to be the full inclusive prices to the Employer for the work described under the several items. The prices and rates shall be exclusive of Value Added Tax. Such prices shall cover all costs and expenses that may be required in and for the construction of the work described, and shall cover the cost of all general risks, liabilities, and obligations set forth or implied in the documents on which the

BIDDER: _____ **DR. JSMLM:** _____

Initial: Authorized signatory/ies: _____ **1.** **Initial:** DR. JSMLM

.....

2

Witness:



tender is based.

6. A price or rate is to be entered, in **BLACK INK**, against each item in the Schedule of Quantities.
7. In the event of the Tenderer failing to price any item it will be held that the Tenderer has made adequate allowance under other items for all labour, material and costs required for the execution, not only of the quantum of work covered by the unpriced item but also for any increase in the said quantum which may have to be undertaken during the course of the Contract.

BIDDER:

DR. JSMLM:

Initial: Authorized signatory/ies:
.....

1.

Initial: DR. JSMLM

2

Witness:



DR JS MOROKA LOCAL MUNICIPALITY



CONTRACT NO: *JSM R02/26-27/W27* : CONSTRUCTION OF KATJIBANE BUS AND TAXI ROUTE PHASE-5

C2.2 BILL OF QUANTITIES

BIDDER:

DR. JSMLM:

Initial: Authorized signatory/ies:
.....

1.

Initial: DR. JSMLM

2

Witness:



DR JS MOROKA LOCAL MUNICIPALITY
 CONTRACT NO: JSM/RO2/25-26W27
 CONSTRUCTION OF KATJIBANE BUS AND TAXI ROUTE PHASE 5

SECTION 1200

ITEM NO	DESCRIPTION	UNIT	QUANTITY	RATE	AMOUNT
1200	<u>GENERAL REQUIREMENTS AND PROVISIONS</u>				
B12.01	(i) Payment of community liason officer and Safety Rep	-	Prov	Sum	R 54 000,00
	(ii) Payment for PSC sittings	-	Prov	Sum	R 10 800,00
	(iii) Payment for Student Training	-	Prov	Sum	R 27 000,00
	(ii) Handling costs and profit in respect of B12.01(i) above	%	R 91 800,00		
B12.02	Structured Training (as specified in part D of the project specification)				
	(a) Generic Skills and Entreprenueral Skills	-	Prov	Sum	R 185 000,00
	(c) Handling costs and profit in respect of sub-items (a) and (b) above	%	R 185 000,00		
	(d) Provision of training venue (only if required)	-	Lump	Sum	R 5 000,00
PS12.05	Protection, removal, relocation and replacement of Utility services.				
	(a) Utility services				
	(i) Protection, removal, relocation and replacement of utility services.		Prov	Sum	250 000,00
	(ii) Handling costs and profit in respect of sub-items (a) (i) above	%	R 250 000,00		
B12/C1.1	Contractor's initial obligation in respect of the OHS Act and Construction Regulations	L/Sum	1,00		
B12/C1.2	Contractor's Time related Obligations in respect of the OHS Act and Construction Regulations	Month	5,00		
B12/C1.3	Submission of Health and Safety File	L/Sum	1,00		
B12/C1.4	Provisional Sum for payment of specialised services OHS Services, Borrowpit Rehabilitation		Prov	Sum	R 250 000,00
	Handling cost and profit in respect of sub item above	%	250 000,00		
B12/C1.5	Compensation to Land Owners		Prov	Sum	R60 000,00
	Handling cost and profit in respect of sub item above	%	R 60 000,00		
1200	TOTAL CARRIED TO SUMMARY				

BIDDER:

DR. JSMLM:

Initial: Authorized signatory/ies:

1.

Initial: DR. JSMLM

2

Witness:



DR JS MOROKA LOCAL MUNICIPALITY
CONTRACT NO: JSM/RO2/25-26W27
CONSTRUCTION OF KATJIBANE BUS AND TAXI ROUTE PHASE 5

SECTION 1300

ITEM NO	DESCRIPTION	UNIT	QUANTITY	RATE	AMOUNT
1300	<u>CONTRACTOR'S ESTABLISHMENT ON SITE AND GENERAL OBLIGATIONS</u>				
13,01	The Contractor's general obligations:				
	(a) Fixed obligations	-	lump	sum	R 250 000,00
	(b) Value-related obligations	-	lump	sum	R 250 000,00
	(c) Time-related obligations	month	5		
1300	TOTAL CARRIED TO SUMMARY				

BIDDER:

DR. JSMLM:

Initial: Authorized signatory/ies:
.....

1.

Initial: DR. JSMLM

2

Witness:



DR JS MOROKA LOCAL MUNICIPALITY
 CONTRACT NO: JSM/RO2/25-26W27
 CONSTRUCTION OF KATJIBANE BUS AND TAXI ROUTE PHASE 5

				SECTION 1400	
ITEM NO	DESCRIPTION	UNIT	QUANTITY	RATE	AMOUNT
1400	<u>HOUSING, OFFICES AND LABORATORIES FOR THE ENGINEER'S SITE PERSONNEL</u>				
14.01	Office and laboratory accommodation:				
	(a) Offices (interior floor space only)	m ²	40		
	(e) Ablution units x 2	m ²	10		
14.02	Office and laboratory furniture:				
	(a) Chairs	number	15		
	(d) Desks, complete with drawers and locks	number	2		
	(f) Conference tables	number	1		
14.03	Office and laboratory fittings, installations and equipment:				
	(a) Items measured by number:				
	(i) 220/250 volt power points	number	2		
	(iii) Double 80 watt fluorescent-light fittings complete with ballast and tubes	number	4		
	(v) Single incandescent-light fittings complete with 100 watt globes	number	4		
	(vi) Wash-hand basins complete with taps and drains	number	1		
	(x) Fire extinguishers, 9,0kg all purpose dry powder type, complete, mounted on wall with brackets	number	2		
	(xi) Air-conditioning units with, 2,2 kW minimum capacity, mounted and with own power connection	number	2		
	(xiv) General-purpose steel cupboards with shelves	number	2		
	(xv) Steel filing cabinets with drawers	number	2		
	(a) Supply PRINTER	number	2		
	Contract Nameboard	number	2,00		
1400	TOTAL CARRIED FORWARD				

BIDDER:

DR. JSMLM:

Initial: Authorized signatory/ies:

1.

Initial: DR. JSMLM

2

Witness:



DR JS MOROKA LOCAL MUNICIPALITY
 CONTRACT NO: JSM/RO2/25-26W27
 CONSTRUCTION OF KATJIBANE BUS AND TAXI ROUTE PHASE 5

ITEM NO	DESCRIPTION	UNIT	QUANTITY	RATE	AMOUNT
	Brought forward				
14.04	Car-ports	number	5		
14.07	Services				
	(a) Services at offices and laboratories:				
	(i) Fixed costs	-	Lump	Sum	R 20 000,00
	(ii) Running costs	month	6,00		
14.08	Rented, hotel and other accommodation:				
	(a) Provisional Sum for providing rented housing, hotel or other accommodation as described in Subsubclause 1403(c)(ii)	-	Prov	Sum	R 50 000,00
	(b) Handling costs and profit in respect of subitem 14.07(a)	%	R 50 000,00		
B14.11	Telecommunications System				
	(a) Supply (1)Cellular Phone	-	Prov	Sum	R 15 000,00
	(b) Costs of calls by Engineer	-	Prov	Sum	R 12 000,00
	(c) Handling costs and profit in respect of subsubitem 14.11(a), (c) above	%	R 27 000,00		
	(d) Provision of Labtop for the use of Engineer.	-	Prov	Sum	R 40 000,00
	Handling costs and profit in respect of subsubitem 14.11(a), (c) above	%	R 40 000,00		
1400	TOTAL CARRIED TO SUMMARY				

C2.2.5

BIDDER:

DR. JSMLM:

Initial: Authorized signatory/ies:

1.

Initial: DR. JSMLM

2

Witness:



DR JS MOROKA LOCAL MUNICIPALITY
CONTRACT NO: JSM/R02/25-26W27
CONSTRUCTION OF KATJIBANE BUS AND TAXI ROUTE PHASE 5

SECTION 1500

ITEM NO	DESCRIPTION	UNIT	QUANTITY	RATE	AMOUNT
1500	ACCOMMODATION OF TRAFFIC				
15,01	Accommodating traffic and maintaining temporary deviations	km	4,00		
15,02	Earthworks for temporary deviations:				
	(a) Shaping of temporary deviations	km	4,00		
	(b) Cut and borrow to fill	m ³	150,00		
	(c) Cut to spoil	m ³	150,00		
B15.03	Temporary traffic-control facilities:				
	(a) Flagmen	man-day	600,00		
	(b) Portable STOP and GO-RY signs	number	4,00		
	(e) Road signs, R- and TR-series, (size indicated)	number	4,00		
	(f) Road signs, TW-series, (size indicated)	number	4,00		
	(g) Road signs, STW-, DTG-, TGS- and TG-series (excluding delineators and barricades)	m ²	4,00		
	(h) Delineators (DTG50J):				
	(i) Single	number	10,00		
	(ii) Mounted back to back	number	8,00		
	(j) Traffic cones 600mm	number	10,00		
	(l) Movable barriers (type indicated)	No	4,00		
	(n) Safety jackets and hats	No	4,00		
15.05	Gravelling and repair of temporary deviations and existing gravel shoulders used as temporary deviations:				
	(a) Temporary deviations	m ³	250,00		
15.06	Watering of temporary deviations	kilolitre	350,00		
1500	TOTAL CARRIED TO SUMMARY				

BIDDER:

DR. JSMLM:
C2.2.6

Initial: Authorized signatory/ies:
.....

1.

Initial: DR. JSMLM

2

Witness:



CONSTRUCTION OF KATJIBANE BUS AND TAXI ROUTE PHASE 5

SECTION 1500

ITEM NO	DESCRIPTION	UNIT	QUANTITY	RATE	AMOUNT
	Brought forward				
15.07	Blading by road grader of:				
	(a) Temporary deviations	km-pass	5,0		
	(b) Existing roads used as temporary deviations	km-pass	5,0		
15.08	Repairs, alterations and/or additions to existing roads used as temporary deviations	-	Prov	Sum	Rate Only
B15.10	Accommodating traffic where the road is constructed in half widths.	km	1,50		
B15.14	Allow providsional sum for:				
	(a) Repair of damaged temporary road signs and delineators	-	Prov	Sum	R 5 000,00
	(b) Replacement of damaged temporary road signs and delineators	-	Prov	Sum	R 5 000,00
1500	TOTAL CARRIED TO SUMMARY				

C2.2.7

BIDDER:

DR. JSMLM:

Initial: Authorized signatory/ies:

1.

Initial: DR. JSMLM

2

Witness:



DR JS MOROKA LOCAL MUNICIPALITY
CONTRACT NO: JSM/RO2/25-26W27
CONSTRUCTION OF KATJIBANE BUS AND TAXI ROUTE PHASE 5

SECTION 1700

ITEM NO	DESCRIPTION	UNIT	QUANTITY	RATE	AMOUNT
1700	<u>CLEARING AND GRUBBING</u>				
17,01	Clearing and grubbing	ha	2,0		
1700	TOTAL CARRIED TO SUMMARY				

C2.2.9

BIDDER:

DR. JSMLM:

Initial: Authorized signatory/ies:

1.

Initial: DR. JSMLM

.....

2

Witness:

.....



DR JS MOROKA LOCAL MUNICIPALITY
 CONTRACT NO: JSM/RO2/25-26W27
 CONSTRUCTION OF KATJIBANE BUS AND TAXI ROUTE PHASE 5

SECTION 1800

ITEM NO	DESCRIPTION	UNIT	QUANTITY	RATE	AMOUNT
1800	<u>DAYWORKS</u>				
B18.01	Labourers:				
	(i) Unskilled	h	50		Rate Only
	(ii) Semi-skilled	h	50		Rate Only
	(iii) Skilled	h	50		Rate Only
B18.02	Foreman	h	50		Rate Only
B18.03	Tipper trucks:				
	(i) 3 - 5 ton	h	50		Rate Only
	(ii) 5.1 - 10 ton	h	50		Rate Only
B18.04	Loader (0,5m³)	h	50		Rate Only
B18.05	Grader (CAT 140G or similar)	h	50		Rate Only
B18.06	LDV	km	50		Rate Only
B18.07	Compaction rollers:				
	(i) Vibratory roller	h	50		Rate Only
	(ii) Tamping roller	h	50		Rate Only
	(iii) Grid roller	h	50		Rate Only
B18.08	Hand controlled compactors				
	(i) Pedestrian roller (Bomag BW90)	h	50		Rate Only
	(ii) Vibratory plate	h	50		Rate Only
	(iii) Rammers	h	50		Rate Only
B18.09	Water truck (min. 10000litre)	h	50		Rate Only
B18.10	Dozer (D7 or similar)	h	20		Rate Only
1800	TOTAL CARRIED TO SUMMARY				

C2.2.10

BIDDER:

DR. JSMLM:

Initial: Authorized signatory/ies:

1.

Initial: DR. JSMLM

2

Witness:



DR JS MOROKA LOCAL MUNICIPALITY
 CONTRACT NO: JSM/R02/25-26W27
 CONSTRUCTION OF KATJIBANE BUS AND TAXI ROUTE PHASE 5

ITEM NO	DESCRIPTION	UNIT	QUANTITY	RATE	AMOUNT		
2100	<u>DRAINS</u>						
22.01 LIC	Excavation for open drains:						
	(a) Excavating soft material situated within the following depth ranges below the surface level:						
	(i) 0 m up to 1,5 m	m3	120				
	(b) Extra over subitem 21.01(a) for excavation in hard material, irrespective of depth	m3	60				
21.02 LIC	Clearing and shaping existing open drains	m3	200				
LI 21.03	Excavation for sub-soil drainage systems:						
LI 21.03	(a) Excavating soft material situated within the following depth ranges below the surface level:						
	(i) 0 m up to 1,5 m	m3	100				
	(b) Extra over subitem 21.03(a) for excavation in hard material, irrespective of depth	m3	15				
21.04	Impermeable backfill to subsoil drainage systems	m3	60				
21.05	Banks and dykes	m3	50				
21.06	Natural permeable material in sub-soil drainage systems (crushed stones).						
	(b) Crushed stone obtained from commercial sources						
	(2) Coarse-graded -19mm surfacing stone.	m3	60				
21.07	Natural permeable material in subsoil drainage						
	(b) Sand from commercial sources						
	(1) Coarse Grade	m3	60				
21.08	Pipes in subsoil drainage systems:						
	(b) Unplasticised PVC pipes and fittings, normal duty complete with couplings						
	(1) 100mm internal dia. Perforated.	m	160				
2100	TOTAL CARRIED TO SUMMARY						

C2.2.11

BIDDER:

DR. JSMLM:

Initial: Authorized signatory/ies:

1.

Initial: DR. JSMLM

.....

2

Witness:

.....



DR JS MOROKA LOCAL MUNICIPALITY
 CONTRACT NO: JSM/RO2/25-26W27
 CONSTRUCTION OF KATJIBANE BUS AND TAXI ROUTE PHASE 5

SECTION 2200

ITEM NO	DESCRIPTION	UNIT	QUANTITY	RATE	AMOUNT
2200	<u>PREFABRICATED CULVERTS</u>				
22,01	Excavation:				
	(a) Excavating soft material situated within the following depth ranges below the surface level:				
	(i) 0 m up to 1,5 m	m ³	300		
	(b) Extra over subitem 22.01(a) for excavation in hard material, irrespective of depth	m ³	80		
22,02	Backfilling:				
	(a) Using the excavated material	m ³	100		
	(c) Extra over subitems 22.02(a) and (b) for soil cement backfilling containing 2% cement	m ³	12		
22.05	Concrete pipe and box culverts:				
	Class 100 D with interlocking joint				
	On Class C Bedding				
	(i) 1000 mm * 600 mm	m	60		
	(ii) 900 mm	m	60		
B22.07	Cast in situ concrete and formwork:				
	(b) (i) In floor slabs for portal or rectangular culverts including formwork, joints and class U2 surface finish (class 25/19)	m ³	40		
	(ii) Between culvert units (class 15/19)	m ³	20		
	(c) In inlet and outlet structures, skewed ends, catchpits, manholes, trust and anchor blocks, including formwork and including class U2 surface finish.				
	(i) Class 25/19 concrete	m ³	12		
	(d) formwork of concrete inder subitem 22,07(c) above				
	(i) Class F1 surface finish	m ²	90		
2200	TOTAL CARRIED FORWARD				

C.2.2.13

BIDDER:

DR. JSMLM:

Initial: Authorized signatory/ies:

1.

Initial: DR. JSMLM

.....

2

Witness:



CONSTRUCTION OF KATJIBANE BUS AND TAXI ROUTE PHASE 5

SECTION 2200

ITEM NO	DESCRIPTION	UNIT	QUANTITY	RATE	AMOUNT
	Brought forward				
22,17	Steel reinforcement				
	(a) Mild steel bars	t	0,10		
	(b) High-tensile steel bars	t	0,10		
	(c) Welded steel fabric ref 195	kg	200,00		
22,18	Brickwork				
	(a) 115 mm thick	m ²	25		
	(b) 230 mm thick	m ²	25		
22,19	Plaster	m ²	30		
22.'20	Benching	m ²	5		
22,23	Service ducts				
	(a) Ordinary pipes				
	(b) Unplasticised PVC Pipes				
	(ii) 150mm diameter	m	30		
PS22.23	(c) Encasing of service duct in 1:12 cement soil mixture (75mm min. all round)	m	30		
PS22.25	Overhaul on excavated material carted to spoil, backfill material (but excluding Portland cement in the case of soil cement, existing structures demolished and removed to spoil, and removing and relaying, and removing and stacking existing prefabricated culverts ,for haul in excess of the free-haul distance.	m ³ -km	30		
22,26	Hand excavation to determine the positions of existing services.	m ³	30		
2200	TOTAL CARRIED TO SUMMARY				

C2.2.14

BIDDER:

DR. JSMLM:

Initial: Authorized signatory/ies:

1.

Initial: DR. JSMLM

2

Witness:



CONSTRUCTION OF KATJIBANE BUS AND TAXI ROUTE PHASE 5

SECTION 2200

ITEM NO	DESCRIPTION	UNIT	QUANTITY	RATE	AMOUNT
	Brought forward				
22,17	Steel reinforcement				
	(a) Mild steel bars	t	0,10		
	(b) High-tensile steel bars	t	0,10		
	(c) Welded steel fabric ref 195	kg	200,00		
22,18	Brickwork				
	(a) 115 mm thick	m ²	25		
	(b) 230 mm thick	m ²	25		
22,19	Plaster	m ²	30		
22.'20	Benching	m ²	5		
22,23	Service ducts				
	(a) Ordinary pipes				
	(b) Unplasticised PVC Pipes				
	(ii) 150mm diameter	m	30		
PS22.23	(c) Encasing of service duct in 1:12 cement soil mixture (75mm min. all round)	m	30		
PS22.25	Overhaul on excavated material carted to spoil, backfill material (but excluding Portland cement in the case of soil cement, existing structures demolished and removed to spoil, and removing and relaying, and removing and stacking existing prefabricated culverts ,for haul in excess of the free-haul distance.	m ³ -km	30		
22,26	Hand excavation to determine the positions of existing services.	m ³	30		
2200	TOTAL CARRIED TO SUMMARY				

C2.2.14

BIDDER:

DR. JSMLM:

Initial: Authorized signatory/ies:

1.

Initial: DR. JSMLM

.....

2

Witness:



DR JS MOROKA LOCAL MUNICIPALITY
 CONTRACT NO: JSM/R02/25-26W27
 CONSTRUCTION OF KATJIBANE BUS AND TAXI ROUTE PHASE 5

					SECTION 2300
ITEM NO	DESCRIPTION	UNIT	QUANTITY	RATE	AMOUNT
2300	CONCRETE KERBING, CONCRETE CHANNELLING, CHUTES AND DOWNPIPES, AND CONCRETE LININGS FOR OPEN DRAINS Please note the item 23,01(i), (ii),(iii) and (v)are to be executed by local Sub-Contractors as per Dr JS Moroka Local Municipality's Instruction				
23,01	Concrete kerbing:				
	(i) Prefabricated mountable kerb, SABS 927 fig 8c, as shown on the Drawings	Prov Sum	1,0	260 000,00	R 260 000,00
	(ii) Prefabricated mountable kerb, SABS 927 fig 12, as shown on the Drawings	Prov Sum	1,0	12 000,00	R 12 000,00
	(iii) Prefabricated mountable kerb, SABS 927 fig 3, as shown on the Drawings	Prov Sum	1,0	60 000,00	R 60 000,00
	(v) Edge beam (200mm deep x 200 wide mm)	Prov Sum	1,0	40 000,00	R 40 000,00
	(vi) Contractor's charges and profit added to the Prov Sums above	%	10%	372 000,00	37 200,00
23,04	Cast in situ concrete chutes (measured by components):				
	(a) Concrete				
	(1) Class 20/19	m ³	11,0		
	(b) Formwork				
	(1) F1 Surface finish	m ²	60		
	(2) F2 Surface finish	m ²	60		
23,07	Trimming of excavations for concrete-lined opened drains:				
	(a) In soft material	m ²	280		
	(b) In hard material	m ²	112		
23,08	Concrete lining for open drains:				
	(a) Cast insitu concrete lining (V and trapezoidal drain) includ formwork.	m ³	120		
	(b) Class U2 surface finish to cast in situ concrete (trapezoidal drain)	m ²	800		
23,10	Sealed joints in concrete linings of open drains (Polysulphide sealants)	m	30,00		
23,12	Steel reinforcement				
	(c) Welded steel fabric ref 195	kg	2145,00		
2300	TOTAL CARRIED FORWARD TO SUMMARY				

C2.2.15

BIDDER:

DR. JSMLM:

Initial: Authorized signatory/ies:

1.

Initial: DR. JSMLM

2

Witness:



DR JS MOROKA LOCAL MUNICIPALITY
 CONTRACT NO: JSM/RO2/25-26W27
 CONSTRUCTION OF KATJIBANE BUS AND TAXI ROUTE PHASE 5

SECTION 3300

ITEM NO	DESCRIPTION	UNIT	QUANTITY	RATE	AMOUNT
	<u>MASS EARTHWORKS</u>				
33.01	Cut and borrow to fill, including all haul :				
	(a) Material in compacted layer thicknesses of 200 mm and less:				
	(i) Compacted to 90% of modified AASHTO density	m ³	1 841		
	(c) Rock fill (as specified in Subclause 3209(c))	m ³	100		
33.04	Cut to spoil, including all haul to spoil site : Material obtained from:				
	(a) Soft excavation	m ³	2 244		
	(b) Intermediate excavation	m ³	1 010		
	(c) Hard excavation(chemical blasting)	m ³	785		
33.07	Removal of unsuitable material (including free-haul of 0,5 km):				
	(a) In layer thicknesses of 200 mm and less:				
	(i) Stable material	m ³	100		
	(ii) Unstable material	m ³	100		
	(b) In layer thicknesses exceeding 200 mm:				
	(i) Stable material	m ³	250		
	(ii) Unstable material	m ³	450		
3300	Carried forward				

BIDDER:

DR. JSMLM:

Initial: Authorized signatory/ies:

1.

Initial: DR. JSMLM

2

Witness:



SCHEDULE B : ROAD CONSTRUCTION

SECTION 3300

ITEM NO	DESCRIPTION	UNIT	QUANTITY	RATE	AMOUNT
	Brought forward				
33.13	Finishing-off cut and fill slopes, medians and interchange areas:				
	(a) Cut slopes	m ²	250		
	(b) Fill slopes	m ²	150		
	<u>OVERHAUL</u> (Section 1600)				
33/16.01	Overhaul on material hauled in excess of a free-haul distance of 0,5 km, for haul up to or through 1,0 km (restricted overhaul)	m ³	4 005		
33/16.02	Overhaul on material hauled in excess of 1,0 km (ordinary overhaul)	m ³ -km	12 000		
3300	TOTAL CARRIED TO SUMMARY				

BIDDER:

DR. JSMLM:

Initial: Authorized signatory/ies:

1.

Initial: DR. JSMLM

2

Witness:



DR JS MOROKA LOCAL MUNICIPALITY
 CONTRACT NO: JSM/RO2/25-26W27
 CONSTRUCTION OF KATJIBANE BUS AND TAXI ROUTE PHASE 5

SECTION 3400

ITEM NO	DESCRIPTION	UNIT	QUANTITY	RATE	AMOUNT
	<u>PAVEMENT LAYERS OF GRAVEL MATERIAL</u>				
34.01	Pavement layers constructed from gravel taken from cut or borrow, including free-haul up to 1,0 km:				
	(a) Gravel insitu roadbed layers compacted to:				
	(i) 93% of modified AASHTO density for a compacted layer thickness of 150 mm	m ³	900		
	(a) Gravel subbase layers compacted to:				
	(i) 95% of modified AASHTO density for a compacted layer thickness of 150 mm (G6)	m ³	900		
34/16.02	Overhaul on material hauled in excess of 1,0 km (ordinary overhaul)	m ³ -km	5 400		
34/32.04	Removal of oversize pavement material	m ³	300		
3400	Carried forward				

C2.2.19

BIDDER:

DR. JSMLM:

Initial: Authorized signatory/ies:

1.

Initial: DR. JSMLM

2

Witness:



DR JS MOROKA LOCAL MUNICIPALITY
CONTRACT NO: JSM/RO2/25-26W27
CONSTRUCTION OF KATJIBANE BUS AND TAXI ROUTE PHASE 5

SECTION 3500

ITEM NO	DESCRIPTION	UNIT	QUANTITY	RATE	AMOUNT
3500	<u>STABILIZATION</u>				
35.01	Chemical stabilization extra over unstabilized compacted layers:				
	(c) Gravel base, 150 mm thick*	m ³	840		
35.02	Chemical stabilizing agent:				
	(a) Ordinary Portland cement	t	45		
35,04	Provision and application of water for curing	kl	1 200		
3500	TOTAL CARRIED TO SUMMARY				

BIDDER:

DR. JSMLM:

Initial: Authorized signatory/ies:

1.

Initial: DR. JSMLM

.....

2

Witness:



DR JS MOROKA LOCAL MUNICIPALITY
CONTRACT NO: JSM/RO2/25-26W27
CONSTRUCTION OF KATJIBANE BUS AND TAXI ROUTE PHASE 5

SECTION 5100

ITEM NO	DESCRIPTION	UNIT	QUANTITY	RATE	AMOUNT
5100	<u>PITCHING, STONEMWORK AND PROTECTION AGAINST EROSION</u>				
LI 51.01	Stone pitching:				
	(b) Grouted stone pitching 150 mm thickness	m ²	200		
5100	GABIONS				
LI 52.01	excavation and backfilling				
	(b) In all other classes of material.	m ³	12		
LI 52.02	Surface preparation for bedding the gabions	m ²	20		
LI 52.03	(a) Galvanised gabions mattresses with cells of 600mm x 1000mm formed by diaphragms using mesh with a nominal size of 80mm manufactured from galvanized wire with a nominal diameter of 2.7mm with diaphragms spaced 1.0m intervals				
	(i) 0.3 x 2.0m x 4.0m	m ³	20		
5100	TOTAL CARRIED TO SUMMARY				

BIDDER:

DR. JSMLM:

Initial: Authorized signatory/ies:

1.

Initial: DR. JSMLM

2

Witness:



DR JS MOROKA LOCAL MUNICIPALITY
 CONTRACT NO: JSM/RO2/25-26W27
 CONSTRUCTION OF KATJIBANE BUS AND TAXI ROUTE PHASE 5

SECTION 5600

ITEM NO	DESCRIPTION	UNIT	QUANTITY	RATE	AMOUNT
	<u>ROAD SIGNS</u>				
56.01	Road sign boards with painted or coloured semi-matt background. Symbols, lettering and borders in semi-matt black or Class I retro-reflective material, where the sign board is constructed from:				
	(c) Prepainted galvanized steel plate (chromadek or approved equivalent):				
	(i) Area not exceeding 2 m ²	m ²	22		
	(ii) Area exceeding 2 m ² but not 10 m ²	m ²	22		
	(iii) Area exceeding 10 m ²	m ²	rate only		rate only
56.02	Extra over item 56.01 for using:				
	(a) Background of retro-reflective material:				
	(i) Class III	m ²	40		
56.03	Road sign supports (overhead road sign structures excluded):				
	(a) Steel Galvenised tubing (diameter and wall thickness indicated) (D75 2mm thick)	t	0,5		
56.05	Excavation and backfilling for road sign supports (not applicable to kilometre posts)	m ³	13		
56.06	Extra over item 56.05 for cement-treated soil backfill	m ³	10		
56.07	Extra over item 56.05 for rock excavation	m ³	5		
5600	Carried forward				

BIDDER:

DR. JSMLM:

Initial: Authorized signatory/ies:

1.

Initial: DR. JSMLM

2

Witness:



SCHEDULE B : ROAD CONSTRUCTION

SECTION 5600

ITEM NO	DESCRIPTION	UNIT	QUANTITY	RATE	AMOUNT
	Brought forward				
B56.11	Gravel drainage layer below road sign footings	m ³	5		
B56.12	Hazard plates:				
	(a) 800 mm x 200 mm	number	18		
	(b) 1 000 mm x 250 mm	number	6		
5600	TOTAL CARRIED TO SUMMARY				

BIDDER:

DR. JSMLM:

Initial: Authorized signatory/ies:
.....

1.

Initial: DR. JSMLM

2

Witness:



DR JS MOROKA LOCAL MUNICIPALITY
 CONTRACT NO: JSM/RO2/25-26W27
 CONSTRUCTION OF KATJIBANE BUS AND TAXI ROUTE PHASE 5

					SECTION 2300
ITEM NO	DESCRIPTION	UNIT	QUANTITY	RATE	AMOUNT
2300	CONCRETE KERBING, CONCRETE CHANNELLING, CHUTES AND DOWNPIPES, AND CONCRETE LININGS FOR OPEN DRAINS <u>Please note the item 23,01(i), (ii),(iii) and (v)are to be executed by local Sub-Contractors as per Dr JS Moroka Local Municipality's Instruction</u>				
23,01	Concrete kerbing:				
	(i) Prefabricated mountable kerb, SABS 927 fig 8c, as shown on the Drawings	Prov Sum	1,0	260 000,00	R 260 000,00
	(ii) Prefabricated mountable kerb, SABS 927 fig 12, as shown on the Drawings	Prov Sum	1,0	12 000,00	R 12 000,00
	(iii) Prefabricated mountable kerb, SABS 927 fig 3, as shown on the Drawings	Prov Sum	1,0	60 000,00	R 60 000,00
	(v) Edge beam (200mm deep x 200 wide mm)	Prov Sum	1,0	40 000,00	R 40 000,00
	(vi) Contractor's charges and profit added to the Prov Sums above	%	10%	372 000,00	37 200,00
23,04	Cast in situ concrete chutes (measured by components):				
	(a) Concrete				
	(1) Class 20/19	m ³	11,0		
	(b) Formwork				
	(1) F1 Surface finish	m ²	60		
	(2) F2 Surface finish	m ²	60		
23,07	Trimming of excavations for concrete-lined opened drains:				
	(a) In soft material	m ²	280		
	(b) In hard material	m ²	112		
23,08	Concrete lining for open drains:				
	(a) Cast insitu concrete lining (V and trapezoidal drain) includ formwork.	m ³	120		
	(b) Class U2 surface finish to cast in situ concrete (trapezoidal drain)	m ²	800		
23,10	Sealed joints in concrete linings of open drains (Polysulphide sealants)	m	30,00		
23,12	Steel reinforcement				
	(c) Welded steel fabric ref 195	kg	2145,00		
2300	TOTAL CARRIED FORWARD TO SUMMARY				

C2.2.15

BIDDER:

DR. JSMLM:

Initial: Authorized signatory/ies:

1.

Initial: DR. JSMLM

.....

2

Witness:



DR JS MOROKA LOCAL MUNICIPALITY
 CONTRACT NO: JSM/RO2/25-26W27
 CONSTRUCTION OF KATJIBANE BUS AND TAXI ROUTE PHASE 5

SECTION 3300

ITEM NO	DESCRIPTION	UNIT	QUANTITY	RATE	AMOUNT
	<u>MASS EARTHWORKS</u>				
33.01	Cut and borrow to fill, including all haul :				
	(a) Material in compacted layer thicknesses of 200 mm and less:				
	(i) Compacted to 90% of modified AASHTO density	m ³	1 841		
	(c) Rock fill (as specified in Subclause 3209(c))	m ³	100		
33.04	Cut to spoil, including all haul to spoil site : Material obtained from:				
	(a) Soft excavation	m ³	2 244		
	(b) Intermediate excavation	m ³	1 010		
	(c) Hard excavation(chemical blasting)	m ³	785		
33.07	Removal of unsuitable material (including free-haul of 0,5 km):				
	(a) In layer thicknesses of 200 mm and less:				
	(i) Stable material	m ³	100		
	(ii) Unstable material	m ³	100		
	(b) In layer thicknesses exceeding 200 mm:				
	(i) Stable material	m ³	250		
	(ii) Unstable material	m ³	450		
3300	Carried forward				

BIDDER:

DR. JSMLM:

Initial: Authorized signatory/ies:

1.

Initial: DR. JSMLM

2

Witness:



SCHEDULE B : ROAD CONSTRUCTION

SECTION 3300

ITEM NO	DESCRIPTION	UNIT	QUANTITY	RATE	AMOUNT
	Brought forward				
33.13	Finishing-off cut and fill slopes, medians and interchange areas:				
	(a) Cut slopes	m ²	250		
	(b) Fill slopes	m ²	150		
	<u>OVERHAUL</u> (Section 1600)				
33/16.01	Overhaul on material hauled in excess of a free-haul distance of 0,5 km, for haul up to or through 1,0 km (restricted overhaul)	m ³	4 005		
33/16.02	Overhaul on material hauled in excess of 1,0 km (ordinary overhaul)	m ³ -km	12 000		
3300	TOTAL CARRIED TO SUMMARY				

BIDDER:

DR. JSMLM:

Initial: Authorized signatory/ies:
.....

1.

Initial: DR. JSMLM

2

Witness:



DR JS MOROKA LOCAL MUNICIPALITY
 CONTRACT NO: JSM/RO2/25-26W27
 CONSTRUCTION OF KATJIBANE BUS AND TAXI ROUTE PHASE 5

SECTION 3400

ITEM NO	DESCRIPTION	UNIT	QUANTITY	RATE	AMOUNT
	<u>PAVEMENT LAYERS OF GRAVEL MATERIAL</u>				
34.01	Pavement layers constructed from gravel taken from cut or borrow, including free-haul up to 1,0 km:				
	(a) Gravel insitu roadbed layers compacted to:				
	(i) 93% of modified AASHTO density for a compacted layer thickness of 150 mm	m ³	900		
	(a) Gravel subbase layers compacted to:				
	(i) 95% of modified AASHTO density for a compacted layer thickness of 150 mm (G6)	m ³	900		
34/16.02	Overhaul on material hauled in excess of 1,0 km (ordinary overhaul)	m ³ -km	5 400		
34/32.04	Removal of oversize pavement material	m ³	300		
3400	Carried forward				

C2.2.19

BIDDER:

DR. JSMLM:

Initial: Authorized signatory/ies:

1.

Initial: DR. JSMLM

2

Witness:



DR JS MOROKA LOCAL MUNICIPALITY
CONTRACT NO: JSM/RO2/25-26W27
CONSTRUCTION OF KATJIBANE BUS AND TAXI ROUTE PHASE 5

SECTION 3500

ITEM NO	DESCRIPTION	UNIT	QUANTITY	RATE	AMOUNT
3500	<u>STABILIZATION</u>				
35.01	Chemical stabilization extra over unstabilized compacted layers:				
	(c) Gravel base, 150 mm thick*	m ³	840		
35.02	Chemical stabilizing agent:				
	(a) Ordinary Portland cement	t	45		
35,04	Provision and application of water for curing	kl	1 200		
3500	TOTAL CARRIED TO SUMMARY				

BIDDER:

DR. JSMLM:

Initial: Authorized signatory/ies:
.....

1.

Initial: DR. JSMLM

2

Witness:



DR JS MOROKA LOCAL MUNICIPALITY
CONTRACT NO: JSM/RO2/25-26W27
CONSTRUCTION OF KATJIBANE BUS AND TAXI ROUTE PHASE 5

SECTION 5100

ITEM NO	DESCRIPTION	UNIT	QUANTITY	RATE	AMOUNT
5100	<u>PITCHING, STONEMWORK AND PROTECTION AGAINST EROSION</u>				
LI 51.01	Stone pitching:				
	(b) Grouted stone pitching 150 mm thickness	m ²	200		
5100	GABIONS				
LI 52.01	excavation and backfillng				
	(b) In all other classes of material.	m ³	12		
LI 52.02	Surface preparation for bedding the gabions	m ²	20		
LI 52.03	(a) Galvanised gabions mattresses with cells of 600mm x 1000mm formed by diaphragms using mesh with a nominal size of 80mm manufactured from galvanized wire with a nominal diameter of 2.7mm with diaphragms spaced 1.0m intervals				
	(i) 0.3 x 2.0m x 4.0m	m ³	20		
5100	TOTAL CARRIED TO SUMMARY				

BIDDER:

DR. JSMLM:

Initial: Authorized signatory/ies:

1.

Initial: DR. JSMLM

.....

2

Witness:



DR JS MOROKA LOCAL MUNICIPALITY
 CONTRACT NO: JSM/RO2/25-26W27
 CONSTRUCTION OF KATJIBANE BUS AND TAXI ROUTE PHASE 5

SECTION 5600

ITEM NO	DESCRIPTION	UNIT	QUANTITY	RATE	AMOUNT
	<u>ROAD SIGNS</u>				
56.01	Road sign boards with painted or coloured semi-matt background. Symbols, lettering and borders in semi-matt black or Class I retro-reflective material, where the sign board is constructed from: (c) Prepainted galvanized steel plate (chromadek or approved equivalent): (i) Area not exceeding 2 m ² (ii) Area exceeding 2 m ² but not 10 m ² (iii) Area exceeding 10 m ²	m ² m ² m ²	22 22 rate only		rate only
56.02	Extra over item 56.01 for using: (a) Background of retro-reflective material: (i) Class III	m ²	40		
56.03	Road sign supports (overhead road sign structures excluded): (a) Steel Galvenised tubing (diameter and wall thickness indicated) (D75 2mm thick)	t	0,5		
56.05	Excavation and backfilling for road sign supports (not applicable to kilometre posts)	m ³	13		
56.06	Extra over item 56.05 for cement-treated soil backfill	m ³	10		
56.07	Extra over item 56.05 for rock excavation	m ³	5		
5600	Carried forward				

BIDDER:

DR. JSMLM:

Initial: Authorized signatory/ies:

1.

Initial: DR. JSMLM

2

Witness:



SCHEDULE B : ROAD CONSTRUCTION

SECTION 5600

ITEM NO	DESCRIPTION	UNIT	QUANTITY	RATE	AMOUNT
	Brought forward				
B56.11	Gravel drainage layer below road sign footings	m ³	5		
B56.12	Hazard plates:				
	(a) 800 mm x 200 mm	number	18		
	(b) 1 000 mm x 250 mm	number	6		
5600	TOTAL CARRIED TO SUMMARY				

BIDDER:

DR. JSMLM:

Initial: Authorized signatory/ies:

1.

Initial: DR. JSMLM

2

Witness:



DR JS MOROKA LOCAL MUNICIPALITY
 CONTRACT NO: JSM/RO2/25-26W27
 CONSTRUCTION OF KATJIBANE BUS AND TAXI ROUTE PHASE 5

SECTION 5700

ITEM NO	DESCRIPTION	UNIT	QUANTITY	RATE	AMOUNT
5700	ROAD MARKINGS				
57,02	Retro-reflective road-marking paint:				
	(a) White line (100mm wide broken or unbroken)	km	1,10		
	(d) White lettering and symbols	m ²	70,0		
57.04	Variations in rate of application:				
	(a) White paint	litre	rate only		rate only
	(b) Yellow paint	litre	rate only		rate only
	(c) Red paint	litre	rate only		rate only
	(d) Retro-reflective beads	kg	rate only		rate only
B57.06	Setting out and premarking the lines (excluding traffic-island markings, lettering and symbols)	km	2,20		
5700	TOTAL CARRIED TO SUMMARY				

C2.2.25

BIDDER:

DR. JSMLM:

Initial: Authorized signatory/ies:

1.

Initial: DR. JSMLM

2

Witness:



DR JS MOROKA LOCAL MUNICIPALITY
 CONTRACT NO: JSM/RO2/25-26W27
 CONSTRUCTION OF KATJIBANE BUS AND TAXI ROUTE PHASE 5

SECTION 5900

ITEM NO	DESCRIPTION	UNIT	QUANTITY	RATE	AMOUNT
5900	<u>FINISHING THE ROAD AND ROAD RESERVE AND TREATING OLD ROADS</u>				
59,01	Finishing the road and road reserve: (b) Single-carriageway road	km	2,50		
5900	TOTAL CARRIED TO SUMMARY				

C2.2.26

BIDDER:

DR. JSMLM:

Initial: Authorized signatory/ies:

1.

Initial: DR. JSMLM

2

Witness:



DR JS MOROKA LOCAL MUNICIPALITY
 CONTRACT NO: JSM/RO2/25-26W27
 CONSTRUCTION OF KATJIBANE BUS AND TAXI ROUTE PHASE 5

SECTION 7300

ITEM NO	DESCRIPTION	UNIT	QUANTITY	RATE	AMOUNT
7300	CONCRETE BLOCK PAVING FOR ROADS				
	Please note the item 73,01(a) and (b) and (c) are to be executed by local Sub-Contractors as per Dr JS Moroka Local Municipality's Instruction				
73.01 LIC	(a) 80 mm thick, Class 25,including 20mm sand bedd	Prov Sum	1,0	1750000,00	1 750 000,00
	(b) Construction of speed hump	Prov Sum	1,0	40 000,00	40 000,00
	(c) Bus Stop Shelters	Prov Sum	1,0	140 000,00	140 000,00
	(d) Contractor's charges and profit added to the Prov Sums above	%	10%	1 930 000,00	193 000,00
73.03 LIC	Provision of approved herbicide and ant poison:				
	(a) Provision of materials	PC Sum	1,0	35 000,00	35 000,00
	(b) Contractor's charges and profit added to the Prime Cost Sum	%	10%		
7300	TOTAL CARRIED TO SUMMARY				

BIDDER:

DR. JSMLM:

Initial: Authorized signatory/ies:

1.

Initial: DR. JSMLM

2

Witness:



DR JS MOROKA LOCAL MUNICIPALITY
CONTRACT NO: JSM/RO2/25-26W27
CONSTRUCTION OF KATJIBANE BUS AND TAXI ROUTE PHASE 5

SECTION 8100

ITEM NO	DESCRIPTION	UNIT	QUANTITY	RATE	AMOUNT
8100	TESTING MATERIALS AND WORKMANSHIP				
81.02	Other special tests requested by the Engineer:				
	(a) Cost of testing	-	PC	Sum	R 57 000,00
	(b) Charge on Prime Cost Sum	%	57 000		
8100	TOTAL CARRIED TO SUMMARY				

BIDDER:

DR. JSMLM:

Initial: Authorized signatory/ies:

1.

Initial: DR. JSMLM

.....

2

Witness:



DR JS MOROKA LOCAL MUNICIPALITY
CONTRACT NO: JSM/RO2/25-26W27
CONSTRUCTION OF KATJIBANE BUS AND TAXI ROUTE PHASE 5



SUMMARY OF SCHEDULE OF QUANTITIES

1200	GENERAL REQUIREMENTS AND PROVISIONS.....	R	_____
1300	CONTRACTOR'S ESTABLISHMENT ON SITE AND GENERAL OBLIGATIONS.....	R	_____
1400	HOUSING, OFFICES AND LABORATORIES FOR THE ENGINEER'S SITE PERSONNEL.....	R	_____
1500	ACCOMMODATION OF TRAFFIC.....	R	_____
1700	CLEARING AND GRUBBING.....	R	_____
1800	DAYWORKS.....	R	_____
2100	DRAINS.....	R	_____
2200	PREFABRICATED CULVERTS.....	R	_____
2300	CONCRETE KERBING, CONCRETE CHANNELING, CHUTES AND DOWNPIPES AND CONCRETE LINING FOR OPEN DRAINS.....	R	_____
3300	MASS EARTHWORKS.....	R	_____
3400	PAVEMENT LAYERS OF GRAVEL MATERIAL.....	R	_____
3500	STABILIZATION.....	R	_____
5100	PITCHING, STONEMWORK AND PROTECTION AGAINST EROSION.....	R	_____
5600	ROAD SIGNS.....	R	_____
5700	ROAD MARKING.....	R	_____
5900	FINISHING THE ROAD AND ROAD RESERVE AND TREATING OLD ROADS.....	R	_____
7300	CONCRETE BLOCK PAVING FOR ROADS.....	R	_____
8100	TESTING MATERIAL AND WORKMANSHIP TREATING OLD ROADS	R	_____
TOTAL R			_____

CALCULATION OF TENDER SUM

SUMMARY OF SCHEDULE OF QUANTITIES TOTAL.....	R	_____
ADD CONTINGENCIES The sum provided here is under the sole control of the Engineer and may be deducted in whole or in part. (The Tenderer must add 2,5% of the total of schedule of quantities)	R	_____
SUBTOTAL R		_____
ADD VALUE-ADDED TAX (VAT) The tenderer shall add 15% of subtotal for VAT	R	_____
TOTAL CARRIED TO FORM OF OFFER	R	_____

BIDDER:

DR. JSMLM:

Initial: Authorized signatory/ies:
.....

1.

Initial: DR. JSMLM

2

Witness:



DR JS MOROKA LOCAL MUNICIPALITY



CONTRACT NO: *JSM R02/25-26/W27: CONSTRUCTION OF KATJIBANE BUS AND TAXI ROUTE PHASE-5*

TOTAL BROUGHT FORWARD	
PLUS 2.5 % CONTINGENCIES	
SUBTOTAL	
PLUS 15% VALUE ADDED TAX	
TOTAL CARRIED FORWARD TO FORM OF OFFER	

BIDDER:

DR. JSMLM:

Initial: Authorized signatory/ies:

1.

Initial: DR. JSMLM

2

Witness:



DR JS MOROKA LOCAL MUNICIPALITY



CONTRACT NO: JSM R02/25-26/W27: CONSTRUCTION OF KATJIBANE BUS AND TAXI ROUTE PHASE-5

C3 Scope of Work

C3.1 DESCRIPTION OF THE WORKS

1.1 Employer’s objectives

The Clients objective is to appoint a contractor for the Construction of Bus & Taxi Route in KATJIBANE .

For Expanded Public Works Programme (EPWP)

The employer’s objectives are to deliver public infrastructure using labour intensive methods. A minimum of 20 Employees are to be from the local community.

1.2 Overview of the works

The work entails the Construction of a **640m x 6m** Block Paving Road in KATJIBANE Village.

1.3 Extent of the works

The proposed scope of works includes the Construction and paving of 640mof the proposed road with 80mm concrete interlocking paving blocks. The scope of works proposed for the upgrading of 0.64 km KATJIBANE access road includes but not limited to the following:

- Establishment and setting out of works
- Clearing and grubbing within road reserve for entire 0.64 km road
- Location and Relocation of Existing Services
- Constructions of Culverts 900mm diameter pipe crossings
- Sideline concrete drains
- Accommodation of Traffic for 0.64 km
- 150 mm Roadbed Preparation
- Construction of 150 mm Subbase Layer

BIDDER: **DR. JSMLM:**

Initial: Authorized signatory/ies: **1.** **Initial:** DR. JSMLM

.....

2

Witness:



- Construction of 150 mm Stabilized Base Layer C3
- Construction of 80mm Concrete Block Paving interlocking
- Construction of accesses, junctions and edge beams
- Installation of mountable kerbs within the road for the entire 0.64 km
- Construction of Speed Humps
- Bus Bay and Shelters 3 panels
- Mass earth works
- Installation of new Road Signs and Road Markings SABS APPROVED
- Finishing off of the Road Reserve

1.4 Location of the works

The works are in KATJIBANE.

1.5 Temporary works

Temporary works will mainly include access roads to the site, site establishment, protection of existing Services, Traffic accommodation etc, all these temporary works should be reinstated on completion of the works by the contractor.

C 3.2 ENGINEERING

C 3.2.1 Drawings

The following drawings are applicable to the contract:

C 3.3 PROCUREMENT

C 3.3.1 Preferential procurement procedures

The works shall be executed in accordance with the conditions specified in the procurement preferencing schedule.

C 3.3.2 Scope of mandatory subcontract work

It is up to the contractor to determine which works should be subcontracted, however any work that is to be sub-contracted must be approved by the Employer.

Competitive tenders shall be invited in respect of each of the portions of the works in accordance with the relevant provisions of the latest edition of the CIDB Standard for Uniformity in Construction Procurement. The Contract Data in the associated procurement documents shall be based on the use of CIDB Standard subcontract (labour only), SAFCEC General conditions of subcontract (2003 edition) (select appropriate option), with minimal project specific variations and amendments that do not change their intended usage.

BIDDER:

DR. JSMLM:

Initial: Authorized signatory/ies:

1.

Initial: DR. JSMLM

2

Witness:



The Employer shall evaluate the tenders received in accordance with the provisions of the Standard Conditions of Tender contained in Annexure F of Standard for Uniformity in Construction Procurement. The evaluation panel shall comprise equal representatives from the Employer and from the Contractor. The Contractor shall without delay enter into contract with the successful tendering subcontractor based on their accepted tender submission. The Contractor shall remain responsible for providing the subcontracted portion of the works as if the work had not been subcontracted.

BIDDER:

DR. JSMLM:

Initial: Authorized signatory/ies:
.....

1.

Initial: DR. JSMLM

2

Witness:



C 3.4 CONSTRUCTION

C 3.4.1 Applicable SANS 2001 standards for construction works

The following parts of SANS 2001 Construction works standards and associated specification data are applicable to the works:

- 1) SANS 2001

The abovementioned South African National Standards make several references to the Specification Data for data, provisions and variations that make these standards applicable to this contract. The Specification Data shall have precedence in the interpretation of any ambiguity or inconsistency between it and these standards. Each item of Specification Data given below is cross-referenced to the clause in the standard to which it mainly applies.

The associated Specification Data is as follows:

SANS 2001	
Essential Data:	
Clause	Specification data
Variations:	
None	
Additional clauses:	
None	

C 3.4.2 EPWP labour intensive specification

The Guidelines for Implementation of Labour Intensive Infrastructure Projects under The Expanded Public Works Programme (EPWP) are applicable in this contract.

C 3.4.3 Plant and materials provided by the employer

None.

C 3.4.4 Services and facilities provided by the employer

None.

C 3.4.5 Plant and equipment

The plant and equipment used on the site shall not be inferior to that described in the Schedule of Plant and Equipment.

BIDDER:

DR. JSMLM:

Initial: Authorized signatory/ies:

1.

Initial: DR. JSMLM

2

Witness:



C 3.5 MANAGEMENT

C 3.5.1 Applicable SANS 1921 standards

The following parts of SANS 1921 Construction works standards and associated specification data are applicable to the works:

- 1) SANS 1921

The abovementioned South African National Standards make several references to the Specification Data for data, provisions and variations that make these standards applicable to this contract. The Specification Data shall have precedence in the interpretation of any ambiguity or inconsistency between it and these standards.

Each item of Specification Data given below is cross-referenced to the clause in the standard to which it mainly applies.

The associated Specification Data is as follows:

SANS 1921-1, Construction and management requirements for works contracts – Part 1: General engineering and construction works	
Clause	Specification data
Essential data	
4.1.7	There are no requirements for drawings, information and calculations for which the contractor is responsible
4.2.1	The responsibility strategy assigned to the contractor for the works is A.
4.2.2	The Consulting Engineer is Mahlangu Behr & Associates Infrastructure Consultants.
4.3.1	The planning, programme and method statements are to comply with the following: 1) bar chart
4.3.3	The notice period for inspection is one Day.
4.7.3	The overbreak allowances for blasting are provided for in the scope of work.
4.9.3	The trees and shrubs which are not to be disturbed will be pointed out on site by the Engineer.
4.12.2	The samples of materials, workmanship and finishes that the contractor is to provide and deliver to the employer are: 1) cleaning of site on completion
4.12.2	The fabrication drawings that the contractor is to provide and deliver to the employer are: 1) None

4.14.3	The office accommodation, equipment, accommodation for site meetings and other facilities for use by the employer and his agents are: 1) Site office which shall be used for site meetings and for the contractor's use. Such an office shall comprise a minimum of 20m ² in area and 3 m high, be ventilated, have good lamination, must be reasonably sound proof, and have a hard floor construction. It shall be furnished with a desk on which drawings can be rolled open and on which there is sufficient writing space and sufficient temporary chairs or benches to accommodate all persons present at site meetings.
4.14.5	The Contractor is required to provide latrine and ablution facilities.
4.14.6	The requirements for the provision and erection of separate sign boards for consultants and subcontractors are: 1) The boards must comply with the official standard type signboard of the Employer and be at least 2750 x 1800 mm high. 2) The boards must be constructed with a firm flat exposed face using suitable material of firm construction, painted and lettered according to the standard drawings available from the Employer on request and mounted on sturdy pipe-standards at a height of 1800 mm above natural ground level.
4.17.1	The requirements for the termination, diversion or maintenance of existing services are: None.
4.17.3	Services which are known to exist on the site are: None.
4.17.4	The requirements for detection apparatus are: None.

BIDDER:

DR. JSMLM:

Initial: Authorized signatory/ies:
.....

1.

Initial: DR. JSMLM

2

Witness:



4.18		The following standards and specifications shall be in addition to the provisions of 4.18: 1) See the scope of works.
Variations		
None		
Additional clauses		
1 Site meetings and procedures		
<p>The Employer's Representative and the Contractor shall hold meetings relating to the progress of the works at regular intervals and at other such times as may be necessary. The Contractor shall attend all site meetings and shall ensure that all persons under his jurisdiction are notified timeously of all site meetings should the Employer's Representative require their attendance at such meetings. The Contractor shall keep on site a set of minutes of all site meetings, daily records of resources (people and equipment employed), a site instruction book, a complete set of contract working drawings and a copy of the procurement document and make these available at all reasonable times to all persons concerned with the contract.</p>		
2 Water and electricity		
<p>The Employer does not warrant that any water supply or electricity supply that may exist is adequate for the proper execution of the works. The responsibility strategies in terms of the tabulation below that will apply to the contract is:</p> <p>a) water : b) electricity :</p>		
		Option
		A
		Contractor responsibility
Water	The Contractor is to provide, and remove and make good upon completion, all the necessary temporary plumbing connections and purchase water from the local authority for the works at his own cost.	
Electricity	The Contractor is to provide, and remove and make good upon completion all the necessary temporary electrical connections and installations and purchase electricity from the local authority / Eskom for the works at his own cost.	

SANS 1921-5, Construction and management requirements for works contracts – Part 5: Earthworks activities which are to be performed by hand.	
Clause	Specification Data
Essential Data:	
5.1	The depth of trenches which are to be excavated by hand is 1,5 metres.
Additional clauses:	
1	<p>Stone pitching and rubble concrete masonry All stone required for stone pitching and rubble concrete masonry, whether grouted or dry, shall be collected, loaded, off loaded and placed by hand. Sand and stone shall be hauled to its point of placement by means of wheelbarrows where the haul distance is not greater than 150m. Grout shall be mixed and placed by hand.</p>
2	<p>Manufactured Elements Elements manufactured or designed by the Contractor, such as manhole rings and cover slabs, precast concrete planks and pipes, masonry units and edge beams shall not individually, have a mass of more than 320kg. In addition the items shall be large enough so that four workers can conveniently and simultaneously acquire a proper hand hold on them.</p>

BIDDER:

DR. JSMLM:

Initial: Authorized signatory/ies:

1.

Initial: DR. JSMLM

2

Witness:



SANS 1921-6, Construction and management requirements for works contracts – Part 6: HIV/AIDS awareness.	
4.2.1(a)	A qualified service provider is a service provider that is one that is accredited or provisionally accredited training service provider in the HIV/AIDS field. A list of accredited service providers can be obtained from the Construction SETA (CETA) (Tel: 011-265 5900), Health and Welfare SETA (HWSETA) (011-622 6852) or on the Health and Welfare SETA website: www.hwseta.org.za .
4.2.1(a)	The HIV/AIDS awareness programme is to be repeated at four month intervals throughout the duration of the contract. (Four times in total, including the initial one at the start of the contract.)

C 3.5.2 Recording of weather

The Contractor shall erect an effective rainfall gauge on the site and record the daily rainfall figures in a book. Such book shall be handed to the employer’s representative for his signature no later than 12 days after rain that is considered to justify an extension of time occurs.

C 3.5.3 Unauthorised persons

The Contractor shall keep unauthorized persons from the works at all times and under no circumstances may any person except guards be allowed to sleep on the building site.

C 3.5.4 Management meetings

There will be monthly compulsory site and technical meetings.

C 3.5.5 Forms for contract administration

Quality control forms will be made available to the contractor in hard copy.

C 3.5.6 Electronic payments

The employer will pay electronically and the contractor must provide correct banking details.

C 3.5.7 Daily records

The contractor shall all the times keep daily records of everything on site.

C 3.5.8 Payment certificates

The contractor must prepare payment certificate every month for approval by the engineer.

C 3.5.9 Communication

The engineer’s representative on this project will be:
 Mr H.O Tsanwani
 Contact number: 072 791 9934

The contact person for the employer is:

Ms. R Mpupa
 Tel: (013) 973 1101

BIDDER: **DR. JSMLM:**

Initial: Authorized signatory/ies: **1.** **Initial:** DR. JSMLM

.....

2

Witness:



C3.6 STANDARD SPECIFICATIONS

The following SANS specifications are also referred to in this document and the Contractor is advised to obtain them from Standards South Africa (a division of SABS) in Pretoria.

SANS 10396: 2003: Implementing Preferential Construction Procurement Policies using Targeted Procurement Procedures

SANS 1914-1 to 6 (2002): Targeted Construction Procurement

SANS 1921 – 1 (2004): Construction and Management Requirements for Works Contracts Part 1: General Engineering and Construction Works and where accommodation of traffic is involved:

SANS 1921-2 (2004): Construction and Management Requirements for Works Contracts; and Part 2: Accommodation of Traffic on Public Roads Occupied by the Contractor.

C3.7 PROJECT SPECIFICATIONS

STATUS

The Project Specification consists of two parts which form an integral part of the contract and supplements the Standard Specifications.

Part A contains a general description of the works, the site and the requirements to be met.

Part B contains variations, amendments and additions to the Standardized Specifications and, if applicable, the Particular Specifications.

In the event of any discrepancy between a part or parts of the Standardized or Particular Specifications and the Project Specification, the Project Specification shall take precedence. In the event of a discrepancy between the Specifications, (including the Project Specifications) and the drawings and / or the Bill of Quantities, the discrepancy shall be resolved by the Engineer before the execution of the work under the relevant item.

The standard specifications which form part of this contract have been written to cover all phases of work normally required for road contracts, and they may therefore cover items not applicable to this particular contract.

BIDDER:

DR. JSMLM:

Initial: Authorized signatory/ies:

1.

Initial: DR. JSMLM

2

Witness:



C3.7.1: PART A: GENERAL

PS-1 PROJECT DESCRIPTION

This project entails the CONSTRUCTION OF KATJIBANE BUS AND TAXI ROUTE PHASE-5.

PS-2 DESCRIPTION OF THE SITE AND ACCESS

2.1 Location of site

KATJIBANE area which is under the jurisdiction of the DR. JSMLM. KATJIBANE is located 51 km from Siyabuswa Mpumalanga Province

2.2 Access to the site

The Site of Works can be accessed from GPS coordinates at 25° 0' 53" S, 28° 63' 15" E.

PS-3 DETAILS OF THE WORKS

A brief detail of the works for which this specification is applicable is as follows:

3.1 Construction of the followings;

- Construction and paving of 640m of the proposed road with 80mm concrete interlocking paving blocks.

3.1 Structures

The nature of the work to be included in this contract is as follows:-

- Establishment of camp and plant on site
- Provision of offices and accommodation of supervisory staff

3.3 Ancillary works

- Accommodation of traffic
- Such other works as may be deemed necessary by the Engineer for the completion of the project.

The Contractor shall make all reasonable provision in the construction programme and its implementation to accommodate the Employer's Development and / or Emerging Contractors.

3.4 Nature of ground conditions and subsoil conditions

A geotechnical investigation of the site has been carried out.

3.5 Climatic conditions

The average annual rainfall is 88.67 mm and the average maximum monthly rainfall in the summer month of December / January is +/- 53.28 mm. little rainfall occurs during the winter month of June with an average monthly precipitation of 1.5 mm.

BIDDER:

DR. JSMLM:

Initial: Authorized signatory/ies:

1.

Initial: DR. JSMLM

2

Witness:



3.6 Labour recruitment conditions

A Community Liaison Officer (CLO) will be appointed through the recruitment process of the Municipality. Recruitment of all local labour should be done through the Community Liaison officer (CLO).

It is mandatory that the Contractor shall interact with the community via proactive project liaison and project participation by its leaders and constituted organisations and forums, as well as through the employment of its people, and these activities shall constitute essential facets of the project.

3.8 Construction in confined Areas

It may be necessary for the Contractor to work within confined areas. Except where provided for in the specifications, no additional payment shall be made for work done in restricted areas. In certain places the width of the fill material and pavement layers may decrease to zero and the working space may be confined. The method of construction in these confined areas largely depends on the Contractor's constructional plant.

However, the Contractor shall note that, unless provided for in terms of the scheduled payment items in the SANS and SABS Standard Specifications or these project specifications, measurement and payment shall be in accordance with the specified cross sections and dimensions only, irrespective of the method used for achieving these cross sections and dimensions, and that the tendered rates and amounts shall include full compensation for all special equipment and construction methods and for all difficulties encountered when working in confined areas and narrow widths, and at or around obstructions, and that no extra payment shall be made nor shall any claim for additional payment be considered in such cases.

PS-4 CONSTRUCTION AND MANAGEMENT REQUIREMENTS

4.1 General

The Contractor is referred to SANS 1921: 2004 parts 1, 2 and 3: Construction and Management Requirements for Works Contracts. These specifications shall be applicable to the contract under consideration and the Contractor shall comply with all requirements relevant to the project.

Certain aspects however require further attention as described hereafter.

4.1.1 Drawings (*Read with SANS 1921 – 1: 2004 clauses 4.1.7; 4.1.11 and 4.1.12*)

The requirements for drawings, information and calculations for which the Contractor is responsible are: None.

The reduced drawings which form part of the tender documents shall be used for tendering purposes only.

The contractor shall be supplied with three complete paper copies of the construction drawings free of charge. The Contractor shall at his own expense produce there from all further paper prints required for the construction of the work.

BIDDER:

DR. JSMLM:

Initial: Authorized signatory/ies:

1.

Initial: DR. JSMLM

2

Witness:



At the completion of the Contract, the Contractor shall return to the Engineer all drawings, provided or made, during the contract period.

Any information which the Contractor has control over and which is required by the Resident Engineer to complete the as-built drawings shall be made available to the Resident Engineer before the completion certificate is issued.

Only written dimensions may be used. Dimensions are not to be scaled from drawings unless ordered by the Engineer. The Engineer will supply all figures / dimensions which are not shown on the drawings. The levels or dimensions given on the drawings are subject to confirmation on site. The Contractor shall submit all levels and dimensions to the Engineer for confirmation before he commences with any structural construction work. The Contractor shall also check all clearances which are given on the drawings and inform the Engineer of any conflicting dimensions.

Any destination names on road signs which may be indicated on the drawings are subject to confirmation by the Engineer before these signs are manufactured.

4.2 Responsibilities for design and construction

Structural Engineer

The structural engineer responsible for the design in accordance with the specification is Morula Consulting Engineers and Project Managers.

4.3 Planning and Programme (Read with SANS1921-1:2004 clause 4.3)

Preliminary programme

The Contractor shall include with his tender a preliminary programme on the prescribed form to be completed by all Tenderers. The programme shall be in the form of a simplified bar chart with sufficient details to show clearly how the works will be performed within the time for completion as stated in the Contract Data.

Tenderers may submit tenders for an alternative Time for Completion in addition to a tender based on the specified Time for Completion. Each such alternative tender shall include a preliminary programme similar to the programme above for the execution of the works, and shall motivate his proposal clearly by stating all the financial implications of the alternative completion time.

The Contractor shall be deemed to have allowed fully in his tendered rates and prices as well as in his programme for all possible delays due to normal adverse weather conditions and special non-working days as specified in the Special Conditions of Contract, in the

Project Specifications and in the Contract Data.

The following constraints shall be taken into account in preparing the preliminary construction programme which must be submitted with the Tender. These same constraints shall apply to the final construction programme.

- a) The Contract time is 6 months. Plant and personnel requirements to complete the

BIDDER:

DR. JSMLM:

Initial: Authorized signatory/ies:

1.

Initial: DR. JSMLM

2

Witness:



- project in 6 months must be incorporated in the Tender.
- b) A high standard of traffic accommodation
- c) The relocation of services are to be determined during construction.
- d) Ancillary works by Emerging Contractors

Programme in terms of Clause 12 of the General Conditions of Contract

It is essential that the construction programme, which shall conform in all respects to Clause 12 of the General Conditions of Contract, be furnished within the time stated in the Contract Data. The preliminary programme to be submitted with the tender shall be used as a basis for this programme. The Contractor's attention is also drawn to clause 40.3 of the General Conditions of Contract 2004.

4.4 Quality Assurance (QA) (Read with SANS 1921 – 1: 2004 clause 4.4)

The Contractor will be solely responsible for the production of work that complies with the Specifications to the satisfaction of the Engineer. To this end it will be the full responsibility of the Contractor to institute an appropriate Quality Assurance (QA) system on site. The Engineer will audit the Contractor's quality assurance (QA) system on a regular basis to verify that adequate independent checks and tests are being carried out and to ensure that the Contractor's own control is sufficient to identify any possible quality problems which could cause a delay or failure.

The Contractor shall ensure that efficient supervisory staff, the required transport, instruments, equipment and tools are available to control the quality of his own workmanship in accordance with his QA-system. His attention is drawn to the fact that it is not the duty of the Engineer or the Engineer's representative to act as foreman or surveyor.

4.5 Management and disposal of water (Read with SANS 1921 - 1: 2004 clause 4.6)

The Contractor shall pay special attention to the management and disposal of water and stormwater on the site. It is essential that all completed works or parts thereof are kept dry and properly drained. Claims for delay and for repair of damage caused to the works as a result of the Contractor's failure to properly manage rain and surface water, will not be considered.

4.6 Earthworks (Read with SANS 1921 - 1: 2004 clause 4.10)

Borrow pits and spoil areas

The borrow pits to be used for this contract shall be pointed out at the Site Inspection. The Contractor shall be permitted to use only those borrow pits approved by the Engineer.

The spoil sites shall be determined on site in conjunction with the Engineer, and the local communities. The Contractor shall be permitted to use only those spoil areas approved by the Engineer.

Should the Contractor wish to use any other tip area for the disposal of soil, rubble, vegetation, etc, its use shall be subject to the approval of the Engineer and the landowner.

BIDDER:

DR. JSMLM:

Initial: Authorized signatory/ies:

1.

Initial: DR. JSMLM

2

Witness:



4.11 Testing (Read with SANS 1921 – 1: 2004 clause 4.11)

Process control

The Contractor shall arrange for all tests required for process control to be done by a laboratory acceptable to and approved by the Engineer.

The Contractor may establish his own laboratory on site or he may employ the services of an independent commercial laboratory. Whatever method is used, the Contractor must submit the results of tests carried out on materials and workmanship when submitting work for acceptance by the Engineer. The costs for these tests shall be deemed to be included in the relevant rates and no additional payment will be made for testing as required.

Acceptance control

The process control test results submitted by the Contractor for approval of materials and workmanship may be used by the Engineer for acceptance control. However, before accepting any work, the Engineer may have further control tests carried out by a laboratory of his choice. The cost of such additional tests will be covered by a provisional sum provided in the schedule of quantities, but tests that failed to confirm compliance with the specifications, will be for the account of the Contractor.

4.14 Site Establishment (Read with SANS 1921 - 1: 2004 clause 4.14)

Contractor's camp site and depot

The Contractor is responsible to provide a suitable site for his camp and to provide accommodation for his personnel and labourers. If the Employer can make any specific site available to the Contractor, such site will be pointed out to the Contractor.

The chosen site shall be subject to the approval of the Engineer, the Local Authorities and the Client. Possible locations for a campsite shall be pointed out at the Site inspection. The Contractor shall conform to all local authority, environmental and industrial regulations.

The Contractor shall make his own arrangements concerning the supply of electrical power and all other services. No direct payment shall be made for the provision of electrical and other services. The cost thereof shall be deemed to be included in the rates and amounts tendered for the various items of work for which these services are required.

The Contractor shall provide security watchmen for the contract as he deems fit at no extra cost for the Employer. The Contractor must ensure that all his employees as well as the employees of his subcontractors are able to identify themselves as members of the construction team.

Accommodation of Employees

No employees except for security guards will be allowed to sleep or be accommodated on the site in urban areas.

No housing is available for the Contractor's employees and the Contractor shall make his own arrangements to house his employees and to transport them to site.

No informal housing or squatting will be allowed.

BIDDER:

DR. JSMLM:

Initial: Authorized signatory/ies:

1.

Initial: DR. JSMLM

2

Witness:



The Contractor shall provide the necessary ablution facilities at his camp site and the site of the works for the use of his employees. Chemical toilets only will be allowed where temporary facilities have to be provided.

4.15 Survey beacons (*Read with SANS 1921 - 1: 2004 clause 4.15*)

The Contractor shall take special precautions to protect all permanent survey beacons or pegs such as bench-marks, stand boundary pegs and trigonometrical beacons, regardless whether such beacons or pegs were placed before or during the execution of the Contract. If any such beacons or pegs have been disturbed by the Contractor or his employees, the Contractor shall have them replaced by a registered land surveyor at his own cost.

4.17 Existing Services (*Read with SANS 1921 - 1: 2004 clause 4.17*)

The Contractor shall make himself acquainted with the position of all existing services before any excavation or other work likely to affect the existing services is commenced.

The Contractor will be held responsible for any damage to known existing services caused by or arising out of his operations and any damage shall be made good at his own expense. Damage to unknown services shall be repaired as soon as possible and liability shall be determined on site when such damage should occur.

A provisional amount is included in the bill of quantities for the protection of services.

Prior to commencing construction activities in a particular area, the Contractor shall also diligently enquire of local landowners as to whether there are any other known services which have not been shown on the drawings but which may be affected by the construction activities in that area, and any such services shall be brought to the attention of the Engineer immediately.

The Contractor shall take note of the requirements of clause 1202 of the standard specifications with regard to services.

4.18 Health and Safety (*Read with SANS 1921 - 1: 2004 clause 4.18*)

4.18.1 General statement

It is a requirement of this contract that the Contractor shall provide a safe and healthy working environment and to direct all his activities in such a manner that his employees and any other persons, who may be directly affected by his activities, are not exposed to hazards to their health and safety. To this end the Contractor shall assume full responsibility to conform to all the provisions of the Occupational Health and Safety Act No 85 and Amendment Act No 181 of 1993, and the OHSA 1993 Construction Regulations 2003 issued on 18 June 2003 by the Department of Labour.

For the purpose of this contract the Contractor is required to confirm his status as mandatory and employer in his own right for the execution of the contract by entering into

an agreement with the Employer in terms of the Occupational Health and Safety Act in the form as included in section C1.2.4

BIDDER:

DR. JSMLM:

Initial: Authorized signatory/ies:

1.

Initial: DR. JSMLM

2

Witness:



Health and Safety Specifications and Plans

(a) Employer's Health and Safety Specification

The Employer's Health and Safety Specification will be included in the tender documents as part of the Project Specifications.

(b) Tenderer's Health and Safety Plan

The Tenderer shall submit with his tender his own documented Health and Safety Plan he proposes to implement for the execution of the work under the contract. His Health and Safety Plan must at least cover the following:

- (i) A proper risk assessment of the works, risk items, work methods and procedures in terms of Regulations 7 to 28;
- (ii) Pro-active identification of potential hazards and unsafe working conditions;
- (iii) Provision of a safe working environment and equipment;
- (iv) Statements of methods to ensure the health and safety of subcontractors, employees and visitors to the site, including safety training in hazards and risk areas (*Regulation 5*);
- (v) Monitoring health and safety on the site of works on a regular basis, and keeping of records and registers as provided for in the Construction Regulations;
- (vi) Details of the Construction Supervisor, the Construction Safety Officers and other competent persons he intends to appoint for the construction works in terms of Regulation 6 and other applicable regulations; and
- (vii) Details of methods to ensure that his Health and Safety Plan is carried out effectively in accordance with the Construction Regulations 2003.

The Contractor's Health and Safety Plan will be subject to approval by the Employer, or amendment if necessary, before commencement of construction work. The Contractor will not be allowed to commence work, or his work will be suspended if he had already commenced work, before he has obtained the Employer's written approval of his Health and Safety Plan.

Time lost due to delayed commencement or suspension of the work as a result of the Contractor's failure to obtain approval for his safety plan, shall not be used as a reason to claim for extension of time or standing time and related costs

Cost of compliance with the OHS Act Construction Regulations

The rates and prices tendered by the Contractor shall be deemed to include all costs for conforming to the requirements of the Act, the Construction Regulations and the Employer's Health and Safety Specification as applicable to this contract.

Should the Contractor fail to comply with the provisions of the Construction Regulations, he will be liable for penalties as provided in the Construction Regulations and in the Employer's Health and Safety Specification.

BIDDER:

DR. JSMLM:

Initial: Authorized signatory/ies:

1.

Initial: DR. JSMLM

2

Witness:



4.18.2 Requirements for Accommodation of Traffic (Read with SANS 1921 - 2: 2004)

General

The Contractor will be responsible for the safe and easy passage of public traffic past and on sections of roads of which he has occupation or where work has to be done near traffic. The travelling public shall have the right of way on public roads, and the Contractor shall make use of approved methods to control the movement of his equipment and vehicles so as not to constitute a hazard on the road.

Accommodation of traffic, where applicable shall comply with SANS 1921-2: 2004: Construction and Management Requirements for Works Contracts, Part 2: Accommodation of Traffic on Public Roads occupied by the Contractor. The Contractor shall obtain this specification from Standards South Africa if accommodation of traffic will be involved on any part of the construction works.

Basic Requirements

The travelling public shall have the right of way on public roads, and the Contractor shall make use of approved methods to control the movement of his equipment and vehicles so as not to constitute a hazard on the road.

The Contractor shall ensure that all road signs, barricades, delineators, flagmen and speed controls are effective and that courtesy is extended to the public at all times.

Failure to maintain road signs, warning signs or flicker lights, etc, in a good condition shall constitute ample reason for the Engineer to suspend the work until the road signs, etc, have been repaired to his satisfaction.

The Contractor may not commence constructional activities affecting existing roads before adequate provision has been made to accommodate traffic in accordance with the requirements of this document and the South African Road Traffic Signs Manual.

The Contractor shall construct and maintain all temporary drainage works necessary for temporary deviations.

The Contractor shall provide and grant access to persons whose properties fall within or adjoin the area in which he is working.

Payment

The Contractor's tendered rates for the relevant items in the Bill of Quantities shall include full compensation for all possible additional costs which may arise from this, and no claims for extra payment due to inconvenience as a result of the modus operandi will be considered.

4.19 Management of the environment (Read with SANS 1921 - 1: 2004 clause 4.19)

Respect for the environment is an important aspect of this contract and the Contractor shall pay special attention to the following:

BIDDER:

DR. JSMLM:

Initial: Authorized signatory/ies:

1.

Initial: DR. JSMLM

2

Witness:



(a) Natural Vegetation

The Contractor shall confine his operation to the limits of the road reserve for the purpose of constructing the works and where applicable detours, shall be sited in consultation with the Engineer and the local communities.

Only those trees and shrubs directly affected by the works and such others as the Engineer may direct in writing shall be cut down and stumped. The natural vegetation, grassing and other plants shall not be disturbed other than in areas where it is essential for the execution of the work or where directed by the Engineer.

(b) Fires

The Contractor shall comply with the statutory and local fire regulations. He shall also take all necessary precautions to prevent any fires. In the event of fire the Contractor shall take active steps to limit and extinguish the fire and shall accept full responsibility for damages and claims resulting from such fires which may have been caused by him or his employees.

(c) Environmental Management Plan

In addition to the above all requirements according to the Environmental Management Plan as detailed in C3.3, Particular Specifications, will be adhered to.

C3.7.2: PART B: AMENDMENTS TO THE STANDARD AND PARTICULAR SPECIFICATIONS

B1 PROJECT SPECIFICATIONS RELATING TO THE STANDARD SPECIFICATIONS AND OTHER ADDITIONAL SPECIFICATIONS

VARIATIONS AND ADDITIONS TO SABS 1200 STANDARDIZED SPECIFICATIONS AND PARTICULAR SPECIFICATIONS

The following variations and additions to the SABS 1200 Standardized Specifications referred to above apply to this Contract. The prefix PS indicates an amendment to SABS 1200. The letters and numbers following these prefixes respectively indicate the relevant Standardized Specification and clause numbers in SABS 1200 to which the variation or addition thereto applies.

BIDDER:

DR. JSMLM:

Initial: Authorized signatory/ies:

1.

Initial: DR. JSMLM

2

Witness:



PSA GENERAL
PSA 3 MATERIAL (Clause 3)

PSA 3.1 QUALITY (Sub-Clause 3.1)

All material required for this contract shall bear the official standardisation mark.

PSA 4 PLANT (Clause 4)

PSA 4.1 CONTRACTOR’S OFFICES, STORES AND SERVICES (Sub-Clause 4.2)

Add the following to this subclause:

PSA 4.1.1 Storage (New Sub-clause)

The Contractor shall supply sufficient protection for perishable material to the satisfaction of the Engineer, and all materials shall be used in the order in which it was delivered. Cement older than three months shall be removed from the site and shall not be used in the Works.

PSA 4.1.2 Restrictions on Employee Accommodation

No housing is available for the Contractor’s employees, and the contractor shall make his own arrangements to house his employees and transport them to site.

The Employer will place at the disposal of the Contractor and area to able him to erect his site offices, workshops, stores, and any temporary camp the Contractor may wish to erect for his personnel. The temporary housing and ablution facilities shall comply with the requirements of the local authority

PSA 4.2 CAPACITY OF PLANT AND EQUIPMENT (New Sub-Clause)

Add as Clause 4.3:

The Contractor shall supply plant and equipment in sound working condition and of adequate capacity to complete the Works well within the period or periods specified or stated in the appendix to the tender.

In addition, he shall have available on the Site adequate standby plant ensure that operations designed to be executed continuously are not disrupted because of breakdown of any plant provided for such operations.

BIDDER:

DR. JSMLM:

Initial: Authorized signatory/ies:

1.

Initial: DR. JSMLM

2

Witness:



PSA 5 CONSTRUCTION (Clause 5)

PSA 5.1.1 SETTING OUT OF THE WORK (Sub-Clause 5.1.1)

The Contractor shall be solely responsible for the execution of the works to the correct line and level.

The Contractor shall carefully set out the works, employing a capable surveyor to the lines and levels gleaned from information provided. The tolerance allowed in setting out shall be 3mm either way.

Work set out by the Contractor shall be checked by the Engineer whereafter any errors be rectified by the Contractor.

The Contractor shall provide at least three days' notice of such a check to the Engineer. The Contractor shall supply any material and labour required for the control survey work by the Engineer including the supply of and placing the necessary pegs, sight rails, etc.

Any assistance, including checking, rendered to the Contractor by the Engineer shall not be held as relieving the Contractor of his responsibility in this respect. Should any portion of these works be constructed incorrectly, the Contractor shall at his own expense rectify the work to the satisfaction of the Engineer.

The Contractor shall be held solely responsible for the protection of all bench marks, reference pegs and level pegs. The Contractor shall establish at least three benchmarks at selected points.

The Contractor shall provide the necessary assistance during any operations necessary in connection with the removal, alteration or safeguarding of any public services.

The relevant authority and Engineer shall be informed of any damages without delay.

PSA 5.2 WATCHING, BARRICADING, LIGHTING AND TRAFFIC CROSSINGS (Sub-Clause 5.2)

Add the following to this subclause:

The Contractor shall ensure that he complies with all the requirements of the authorities concerned with respect to the safety of the works and labourers, including the provision and wearing of protective clothing. Any negligence or non-compliance of any of these requirements shall be viewed in a serious light and shall be sufficient reason for the Engineer to order the immediate suspension of the total extent of the Works.

The Contractor shall provide for artificial lighting for any part of the Works that may be required for the proper execution of the work.

BIDDER:

DR. JSMLM:

Initial: Authorized signatory/ies:

1.

Initial: DR. JSMLM

2

Witness:



The tendered rate shall include full compensation for providing all plant, equipment, tools, transport, labour, supervision, flagmen, guards, signs, lights, barricades and all other incidentals necessary for the proper maintenance of an alternative road.

Item	Unit
Accommodation of traffic.....	Sum

PSA 5.4 PROTECTION OF OVERHEAD AND UNDERGROUND SERVICES (Sub-Clause 5.4)

Add the following to the subclause:

Before commencing any excavation, the Contractor shall verify the position of all known or suspected obstacles by inspection of the site, examination of drawings or, where necessary by the excavation of trial holes.

The Contractor shall take cognizance of restrictions imposed by service authorities with respect to operations of mechanical equipment adjacent to or near their services. In particular the relevant authority shall be advised by the Contractor, at least 48 hours in advance, of any operation within 3,0m, measured on a horizontal plane to the estimated position of the authority's service, so that the authority can make arrangements for the supervision of the operation by his staff.

The Contractor will be held responsible for any damage to known services (i.e. services that are within the Site and are shown on the drawings or could reasonably be located by him in good time) and he shall take all necessary measures to protect them. All work or protective measures shall be subject to approval. In the event of a service being damaged, the Contractor shall immediately notify the authorities concerned as well as the Engineer. The Contractor shall not repair any such service unless instructed to do so.

The lump sum tendered shall also include full compensation for all negotiations with private owners or public authorities controlling services to be opened to determine their exact position, or to be relocated and/or protected.

PSA 5.5 SPECIAL WATER CONTROL (Sub-Clause 5.5)

The rates tendered and paid for excavation shall include for dewatering as may be necessary.

BIDDER:

DR. JSMLM:

Initial: Authorized signatory/ies:

1.

Initial: DR. JSMLM

2

Witness:



PSA 5.6 PREVENTION OF DUST NUISANCE (Sub-Clause 5.6)

The Contractor's attention is drawn to the presence of existing dwellings on and adjoining the site are vulnerable to dust nuisance and traffic hazards which might arise from the Contractor's operations. The Contractor is particularly required to take all necessary precautions, including limiting the length of open trenches to 200 metres, watering where appropriate, to prevent dust blowing from construction material and spoil heaps and/or ground stripped of vegetation cover. The Contractor is to allow for the cost of this work as a time related item in the Preliminary and General section of the Schedule of Quantities.

PSA 5.8 GROUND AND ACCESS TO WORK (Sub-Clause 5.8)

Add the following to Sub-clause 5.8

Access to properties should be maintained at all the times. All fences and other structures that have been damaged or interfered with by the Contractor shall be restored to a condition at least equivalent to their original conditions.

PSA 6.2 DEGREE OF ACCURACY (Sub-Clause 6.2)

Delete this sub-clause and replace with the following:

The Contractor shall construct each of the various parts of the Works to the degree of accuracy specified in the relevant standardized specification.

PSA 7 TESTING

PSA 7.2 APPROVED LABORATORIES (Sub-Clause 7.2)

Add the following to this sub-clause:

No laboratory facilities are required on site. The Contractor shall use an independent laboratory for the necessary tests.

The cost of all testing to be carried out by the Contractor in terms of the requirement of the relevant SABS 1200 standards shall be included in the rates for the various work items listed in the Schedule of Quantities. No separate payments shall be made in this regard.

BIDDER:

DR. JSMLM:

Initial: Authorized signatory/ies:

1.

Initial: DR. JSMLM

2

Witness:



The Engineer may order the Contractor to arrange special check tests to be carried out by an approved independent laboratory. The results of these tests shall be made available to the Contractor.

The cost of special check test ordered by the Engineer shall be borne by the Employer if the test results indicate compliance with the specification and by the Contractor if the results indicate non-compliance with the specification.

PSA 8 MEASUREMENT AND PAYMENT (Clause 8)

PSA 8.1.1 METHOD OF MEASUREMENT, ALL SECTIONS (Sub-Clause 8.1.1)

In no case will any dimensions be allowed or any quantities are included in the measurement for payment which shall exceed the dimensions required by the contract or as ordered in writing by the Engineer in the case of extra work.

The quantities as shown in the Bill of Quantities are estimated quantities and are used for comparing tenders and awarding of the contract. It shall be noted that only the actual work executed or materials supplied will be measured and paid for, therefore billed quantities may be increased or decreased as allowed for in the General Conditions of Contract.

PSA 8.5 PROVISIONAL SUMS (Sub-Clause 8.5)

PSA 8.5.1 Testing of Materials (Sub-Clause 8.5.1)

The Engineer reserves the right to carry out any test he deems necessary using commercial laboratories to ensure compliance of the materials supplied for use in the works with the requirements of the Specification, the Contractor will be required to pay the account of the laboratory concerned, but such payments will be recoverable under the provisional sum allowed for in the Schedule of Quantities. The Contractor's tendered mark-up must allow for arranging the necessary testing and for payment, if applicable, through the contract.

Item	unit
Testing of Materials by the Engineer	Prov. sum

5.2.2 PSAB ENGINEER'S OFFICE

PSAB 3 MATERIALS (Clause 3)

PSAB 3.1 NAMEBOARDS (Sub-Clause 3.1)

Add the following to the subclause:

Notwithstanding the provisions of Subclause 3.1 of SABS 1200 AB, the details of the name board will be available from the Engineers.

BIDDER:		DR. JSMLM:
Initial: Authorized signatory/ies:	1.	Initial: DR. JSMLM
	2.	
Witness:		



PSAB 3.2 OFFICE STRUCTURE (Sub-Clause 3.2)

Delete this sub-clause and replace with the following:

The Contractor shall provide the following furnished offices for the use of the Engineer and the Client. Each office shall consist of one room with the following floor area:

- i) Engineers office - 12m²

The clear height of all offices between floor and ceiling shall be 2,5m minimum. All windows shall be of the type than can be open over the full window area:

Each office shall be weatherproof, shall have a concrete floor and shall be provided with insulation, with an acceptable type of door with a secure lock, and two opening windows of glazed area at least 3m². Each office shall be well ventilated and shall be insulated as to provide comfortable working conditions.

The internal furnishings of each office shall include:

- a) one trestle table, 2m long x 1m wide x 0,9m high, with a smooth top;
 - b) one desk having a top of size at least 1,5m x 0,9m and at least two lockable drawer;
- c) two chairs;
- d) an acceptable blind on each window;
- e) a wash-hand basin inside the office;
- f) acceptable lighting;
- g) provision for heating in winter and cooling in summer;
- i) Fifteen comfortable seating chairs around conference table.

PSAB 3.3 CAR PORTS (New Sub-Clause 3.3)

The Contractor shall provide one car port for the use of the Engineer. The car port shall be so constructed that the vehicles parked under them will at all-time be shaded from direct sunlight..

PSAB 3.4 SURVEY EQUIPMENT (New Sub-clause 3.4)

Add the following:

The Contractor shall provide the following survey equipment on the site from the commencement to the completion of the Works:

- 1 Tachometer capable of reading 20 seconds of arc;
- 1 Engineer's level with 360° circle and aluminium staff;

BIDDER:

DR. JSMLM:

Initial: Authorized signatory/ies:

1.

Initial: DR. JSMLM

2

Witness:



- 2 Tachometer staffs graduated metrically;
- 1 Steel tape of length 30m;
- 5 Ranging rods 2m in lengths;
- 1 Nylon tape of length 100m.

The tachometer may be shared by arrangement between the Contractor and the Engineer's Representative, but the remaining instruments shall be provided for the exclusive use of the Engineer's Representative. The Contractor shall keep the equipment continuously insured against any loss, damage, or breakage and he shall indemnify the Engineer and the Employer against any claims in this regard. Upon completion of the whole of the Works, the ownership of the equipment shall revert to the Contractor.

The Contractor shall maintain the equipment in good working order and keep it clean throughout the contract period.

Item Unit

Provide and maintain survey equipment.....Sum

The rate shall cover the charges for the provision, insurance and maintenance of the equipment.

PSAB 3.5 SITE INSTRUCTION BOOKS (New Sub-Clause 3.5)

Throughout the construction period the Contractor shall supply a carbon triplicate book as a site instruction book.

This book shall be kept on Site and shall be accessible to both the Contractor and the Engineer's Representative at all times. It shall be used:

- (a) by the Contractor for:
 - (i) providing the Engineer's Representative with any information regarding the construction of the Works which may be requested, and
 - (ii) giving notification in writing as required by any of the relevant clauses of the General Conditions of Contract, and
- (a) by the Engineer's representative for the purpose of writing day-to-day instructions and confirming any verbal information or instruction given to the Contractor.

BIDDER:

DR. JSMLM:

Initial: Authorized signatory/ies:

1.

Initial: DR. JSMLM

2

Witness:



PSAB 4 PLANT (Clause 4)

PSAB 4.1 TELEPHONE (Sub-Clause 4.1)

The Engineer to provide his own cellular phone. The Engineer shall be responsible for the supply, maintenance, payment of accounts, etc, of the cellular phone.

PSAB 5 CONSTRUCTION (Clause 5)

PSAB 5.5 SURVEY ASSISTANTS (Sub-clause 5.5)

The Contractor shall make available to the Engineer or his Representative two suitably experienced survey assistants to assist on and about the Site with survey and measurements.

PSAB 8 MEASUREMENT AND PAYMENT (Clause 8)

Delete Clause 8 and insert the following:-

The method of measurement as described in Subclause 8.1.2 (b) and (d) of SABS 1200A shall apply and shall be by the lump sum or by number as indicated in PSAB 8.1.

PSAB 8.1 ENGINEER'S FACILITIES ON SITE (Sub-Clause 8.1)

PSAB 8.1.1 Fixed Charge and Value Related Items (Sub-Clause 8.1.1)

Payment for fixed-charge and value-related items with respect to facilities to be provided for the Engineer will be affected in accordance with Clause PSA 8.3 as applicable.

Item	Unit
Fixed Charge and Value-Related Items	
(a) Furnished office and toilets	sum
(b) Name boards	No.

i. PSAB 8.1.2 Time-Related Items

BIDDER:

DR. JSMLM:

Initial: Authorized signatory/ies:

1.

Initial: DR. JSMLM

2

Witness:



Payment for time-related items with respect to facilities to be provided for the Engineer, will be affected in accordance with Clause

Item	Unit
Time Related Items	
(a) Furnished offices	Sum
(b) Name boards	No.

5.2.3 PSC SITE CLEARANCE

PSC 3.1 DISPOSAL OF MATERIAL (Sub-Clause 3.1)

Add to this subclause :

Material obtained from clearing and grubbing from the demolition structure shall be disposal of in a borrow pit indicated by the Engineer and shall be finished to the satisfaction of the Engineer.

PSC 3.3 CLEANING CONCRETE CHANNELS AND S/WATER PIPES (New Sub-Clause 3.3)

All the Material obtained from clearing and grubbing and from the demolition of structures shall be disposed of in a borrow pit indicated by the Engineer and shall be finished to the satisfaction of the Engineer.

PSC 3.5 REMOVAL OF THE EXISTING CONCRETE CHANNEL (New Sub-Clause 3.5)

The removal of existing asphalt surfacing will involve the breaking out, removal, loading and disposal of the surfacing within a free haul distance of 2.0km.

BIDDER:

DR. JSMLM:

Initial: Authorized signatory/ies:

1.

Initial: DR. JSMLM

2

Witness:



5.2.5 PSDM EARTHWORKS (Roads, Subgrade)

PSDM 3 MATERIALS (Clause 3)

PSDM 3.1 CLASSIFICATION OF EXCAVATED MATERIAL (Subclause 3.1)

Delete this subclause and replace with the following:

Distinction shall be drawn, for payment purposes, between excavation in hard and soft material. All road bed excavation shall be classified in accordance with the following classification.

PSDM 1.1.1 Soft excavation

Soft excavation shall be excavation in all existing fill material as well as excavation in material which can be efficiently removed by any of the following plant.

A bulldozer having a mass, including the mass of the ripper if fitted of 35 ton and having a flywheel power of approximately 220 kW.

PSDM 1.1.2 Hard excavation

Hard excavation shall be excavation in material which cannot be efficiently ripped by plant as described in PSDM 1.1.1. This excavation generally includes material such as formation of unweathered rock which can only be removed after blasting or boulders of 0,5m³ or larger in volume.

The Contractor shall be at liberty to use any method he wishes to excavated any class of material, but the method of excavation shall, however, not dictate the classification of the excavation.

The Engineer shall decide under which one of the above classes any excavation shall be classified and paid for. In the first instance the classification shall be based on inspection of the material to be excavated and the method of excavated and the method of excavation proposed by the Contractor. In the even of disagreement between the Contractor and the Engineer, the Contractor shall, if required, make available such mechanical equipment as specified in order to test the reasonable removability or otherwise of the material. The decision of the Engineer as to the classification shall thereafter be final and binding.

BIDDER:

DR. JSMLM:

Initial: Authorized signatory/ies:
.....

1.

Initial: DR. JSMLM

2

Witness:



The Contractor shall immediately inform the Engineer as and when the nature of the material being excavated changes to the extent that a new classification for further excavation is warranted. Failure on the part of the Contractor to timeously advise the Engineer shall entitle the Engineer to classify, in his sole discretion, such excavation as may have been executed in material of a different nature.

PSDM 4 PLANT (Clause 4)

Add the following to this clause.

The following plant are necessary for road preparation:

a) Vibrant roller

The vibrator roller must be able to apply a combined static and dynamic load of not less than 120 kN/m at a working frequency of 1500 r.p.m. maximum.

b) Impact roller

The impact roller shall be a single multi surface roller with a maximum of five flat or nearly flat surfaces and a roller mass of 8 to 10 tons. The roller and tow mechanism, which shall be of the free fall type, shall be designed to make all the energy necessary to take the roller onto the ridge between two flat surfaces available for distribution at impact when the roller falls. The roller shall be towed at a speed of between 8 and 10 kilometres per hour.

PSDM 5.1 CONSTRUCTION (Clause 5)

PSDM 5.1.2 ACCOMMODATION OF TRAFFIC (Subclause 5.1.2)

Add the following to this subclause:

Where by reason of difficult terrain or for any other reason, the construction of bypasses is unfeasible, the Contractor shall, upon the written instruction of the Engineer, construct the road in half widths to allow traffic to use that half of the road not under construction. The length of the half-width construction shall be kept to a minimum, with provision for traffic travelling in opposite directions to pass at frequent intervals.

The Contractor shall arrange his work so as to allow traffic to have free one-way access to at least half the width of the roadway at all times during the construction period. He shall maintain that half of the road, which is being used for traffic for the time being, free from corrugations, to the satisfaction of the Engineer.

Wherever possible, the Contractor shall ensure that the entire road width shall be open at night and shall be left, at the end of each day's work, in good and safe trafficable condition to the satisfaction of the Engineer.

BIDDER:

DR. JSMLM:

Initial: Authorized signatory/ies:

1.

Initial: DR. JSMLM

2

Witness:



Should the road not be in a safe trafficable condition for two-way traffic over the entire width at the end of each day's work, the Contractor shall provide adequate flagmen, signs, barricades, lights and the necessary staff at his own cost to ensure a reasonably free flow of traffic alternately in each direction throughout the entire period when the roadway is open to one-way traffic only.

PSDM 5.2 METHODS AND PROCEDURES

PSDM 5.2.1 STRIPPING OF SITE (Subclause 5.2.1)

Add the following to this subclause.

Before the Contractor does any roadbed preparation, he shall get instructions from the Engineer on any stripping of topsoil or clearing and grubbing that may be required. This work shall be carried out according to SABS 1200C "Site Clearance".

During the compaction of the roadbed with an impact roller if required by the Engineer the roadbed shall be graded before each pass if, according to the Engineer, the surface is uneven and prevents the flat surface of the impact roller to fall uneven.

PSDM 5.2.3 PREPARATION OF THE ROADBED (Subclause 5.2.3)

Add the following as subclause 5.2.3.4.

PSDM 5.2.3.1 Removal of unsuitable material

Any roadbed material that will, according to the judgement of the Engineer, have a detrimental effect on the quality of the finished street, shall be removed to the depth and width as instructed by the Engineer, and will be disposed of according to specification. It shall then be backfilled with approved imported material and compacted to the specified compaction.

The Engineer may instruct the Contractor to remove over wet material which cannot form a solid layer or platform, and replace it with approved dry material. The Contractor will be paid for this operation if the Engineer is convicted that the material will not dry out in a reasonable time in spite of adequate temporary drainage and that the condition may not have been prevented by reasonable preplanning to build the work during the dry season.

BIDDER:

DR. JSMLM:

Initial: Authorized signatory/ies:

1.

Initial: DR. JSMLM

2

Witness:



PSDB 8 MEASUREMENT AND PAYMENT (Sub-Clause 8)

PSDM 8.1 BASIC PRINCIPLES (Subclause 8.1)

Change the following in this subclause:

The free haul distance will be 2,0km.

PSDM 8.1.1 ACCOMMODATION OF TRAFFIC (New Sub-Clause)

Item	Unit
Accommodation of traffic where the road is constructed in half-widths	
Sum	

The unit of measurement for accommodating traffic where the road is constructed in half-widths shall be the metre measured along the centre line of the road which is constructed in half-widths on the written instruction of the Engineer.

The tendered rate shall include full compensation for providing all plant, equipment, tools, transport, labour, supervision, flagmen, guards, signs, lights, barricades and all other incidentals necessary for the proper and safe handling of traffic as specified and shall include full compensation for all additional costs and work resulting from construction of the road in half-widths

5.2.6 PSGA CONCRETE (Small Works)

PSGA 4 PLANT (Clause 4)

PSGA 4.4.1 FINISH OF CONCRETE (Sub-Clause 4.4..2)

- Change this sub-clause as follows :
- The quality of the finished concrete surface shall be as follows:
- All off-shutter concrete from 150mm underneath the ground level ... Smooth.
- Unseen concrete up to 150 mm underneath the ground level ... Rough.

BIDDER:

DR. JSMLM:

Initial: Authorized signatory/ies:

1.

Initial: DR. JSMLM

2

Witness:



PSGA 5.1.2 FIXING OF REINFORCEMENT (Subclause 5.1.2)

Add to this subclause :
No welding shall be allowed.

PSGA 5.3.1.5 STRENGTH CONCRETE (Subclause 5.4.1.5)

Add to this subclause :

The following classes of concrete of concrete shall be used in the following positions:

- Class 15/19 Blinding, mass concrete, encasement of pipes, etc.
- Class 20/19 Strip foundation for brick walls and mass foundation.
- Class 30/19 All structural concrete, including concrete floors and paving.

The Contractor shall design trial mixes in accordance with SABS 0100, Part II 1980, Appendix B. The target strength of the trial mix shall be determined using K equal to 1,7 and a standard deviation Mpa for a "good" degree of site control. The average 28 day cube strength of the trial mix shall equal or exceed the target strength. The Contractor shall submit the trial mixes and the 7 and 28 day test results to the Engineer for approval. No concreting may proceed until the trial mixes have been approved.

PSGA 5.4.1.6 READY MIXED CONCRETE (Subclause 5.4.1.6)

Delete the subclause and replace with the following:

Ready-mixed concrete will be allowed on the site, provided the nominal mix proportions given in S 1200 GA Clause 8.4.1, apply. The prior approval of the Engineer is however required.

PSGA 5.4.2.3 AGGREGATES (Subclause 5.4.2.3)

Aggregates

Add to this clause.

Volume batching is permitted for concrete pours of up to 5,0m³. All greater quantities shall be weigh batched to an accuracy of 2%.

BIDDER:

DR. JSMLM:

Initial: Authorized signatory/ies:
.....

1.

Initial: DR. JSMLM

2

Witness:



PSGA 5.4.3(e) MIXING (Subclause 5.4.3 (e))

Delete this subclause and replace with the following:

- (e) Concrete shall be placed within thirty minutes of the start of mixing.

PSGA 5.4.8 CONCRETE SURFACES (Clause 5.4.8)

Add the following:

Concrete surface finishes required shall be indicated on the drawings and shall be classified as follows:

- a) Rough : This shall comprise a lightly ridged surface as struck off with a tamping board. Degree of accuracy III is required. This finish shall provide a good key for subsequent finishing with a screed or bituminous carpet.
- b) Smooth wood float : The surface shall be wood floated to a uniform surface free of trowel marks and to Degree of Accuracy II.
- c) Smooth steel float : The surface shall be accurately struck off and floated and finished with a steel float to a smooth and uniform surface, free of trowel marks, to Degree of Accuracy I. Rubbing with a carborundum stone will be permitted but no plastering to correct imperfections will be permitted.

BIDDER:

DR. JSMLM:

Initial: Authorized signatory/ies:

1.

Initial: DR. JSMLM

2

Witness:



PSGA 5.4.11 CONSTRUCTION JOINTS (CLAUSE 5.4)

Add to this clause

Concrete shall be carried out continuously up to the locations where joints are shown on the drawings or up to approved locations. Joints shall be constructed in accordance with the details shown on the drawings.

The Contractor shall continue concreting through meal breaks or after normal working hours in order to complete work up to a construction joint and no extra payment shall be made to the Contractor for working overtime.

If, because of an emergency (such as a breakdown of the mixing plant or the occurrence of unsuitable weather), concreting has to be interrupted, concrete shall be finished off at the place of stoppage in the manner that will least impair the durability, appearance, and proper functioning of the concrete.

PSGA 5.4.12 JOINT SEALING (New Sub-Clause)

Add to this clause:

Joints shall be formed as indicated on the drawings, using bitumen impregnated fibre board or closed cell expanded polyethylene compressible joint filler complying with AASHTO Specification M153.

Joints shall be sealed as indicated on the drawings, using rubberised bitumen joint sealant for concrete pavement complying with BS5212. Where indicated on the drawings joint sealant shall be backed by a Polythene Tape bonebreaker.

The use of the joint former and joint sealing materials and all joint sealing shall be carried out by workmen experience in the use of the materials and shall be strictly in accordance with the instruction and recommendations of the manufacturer and supplier.

PSGA 5.4.6.3 MECHANICAL VIBRATION (New Sub-Clause)

Delete this subclause and replace with the following:

Only mechanical vibrations shall be accepted for the compaction of the concrete. Any other method of compaction shall only be accepted with the written approval by the Engineer.

BIDDER:

DR. JSMLM:

Initial: Authorized signatory/ies:
.....

1.

Initial: DR. JSMLM

2

Witness:



PSGA 5.4.8.2 WATERTIGHT CONCRETE (Subclause 5.4.8.2)

Add to this subclause :

Manholes and the stormwater channel shall be water tights and no water leakage will be allowed at the joints.

PSGA 6 TOLERANCES (Clause 6)

PSGA 6.1 GENERAL (Subclause 6.1.1)

All concrete, excluding blinding and mass concrete, shall comply with the specified tolerances, except where a different tolerance is shown on the drawings, in which case the specification on the drawing shall prevail.

PSGA 6.4 TOLERANCES (Clause 6.4)

Degree of accuracy required is (II).

PSGA 7 TESTS (Clause 7)

PSGA 7.1.1 FACILITIES (Sub-Clause 7.1.1)

Facilities

Add the following :

The Contractor shall be fully responsible for sampling and testing the concrete at the frequency specified.

PSGA 7.1.2.2 FREQUENCY OF SAMPLING (Sub-Clause 7.1.2.2)

Add the following :

At least one sample sufficient for 3 cubes and a slump test shall be taken from each day's casting and from at least every 20m³ of concrete of each grade placed. More frequent slump tests shall be take should the consistency of the concrete be seen to vary.

BIDDER:

DR. JSMLM:

Initial: Authorized signatory/ies:
.....

1.

Initial: DR. JSMLM

2

Witness:



C3.7.3 : PART C : ENVIRONMENTAL MANAGEMENT SPECIFICATION

1 General

In order to ensure that the construction works is carried out in an environmentally sensitive matter, strict compliance to the Environmental Management Plan (EMP) guidelines is required. The purpose of the EMP is to:

- Encourage good management practices through planning and commitment to environmental issues,
- Provide rational and practical environmental guidelines to:
 - i. Minimise disturbance of the natural environment,
 - ii. Prevent pollution of land, air and water,
 - iii. Prevent soil erosion and facilitate re-vegetation.
- Adopt the best practicable means available to prevent or minimise adverse environmental impact,
- Develop waste management practices based on prevention, minimisation, recycling, treatment or disposal of wastes,
- Train employees and contractors with regard to environmental obligations.

2 Training and Induction of Employees

- The Contractor has a responsibility to ensure that all those people involved in the project are aware of and familiar with the environmental requirements for the project (this includes sub-contractors, casual labour, etc.). The CMP shall be part of the terms of reference for all contractors, sub-contractors and suppliers.

3 Complaints Register and Environmental Incident Book

Any complaints received by the project team from the public will be recorded. The complaint should be brought to the attention of the site manager, who will respond.

The following information must be recorded:

- Time, date and nature of the complaint,
- Type of communication (telephone, letter etc),
- Name, contact address and telephone number of the complainant,
- Response and investigation undertaken and
- Actions taken and by whom.

All complaints received will be investigated and a response given to the complainant within 14 days.

All environmental incidents occurring on the site will be recorded. The following information will be provided:

- Time, date, location and nature of the incident,
- Actions taken and by whom.

4 Site Cleanliness and Neatness

- Location of a construction camp is to be approved by the Engineer and is to be restored to its previous condition after completion of construction.
- The construction camp should preferably be fenced with a 1.8m bonnox fence or similar approved.

BIDDER:

DR. JSMLM:

Initial: Authorized signatory/ies:

1.

Initial: DR. JSMLM

2

Witness:



- All materials, equipment, plant and vehicles must be stored within the construction camp.
- A dedicated area must be made available for construction staff to change and store their personal belongings.

5 Access

Access to existing roads, schools, buildings, shops and residential properties must not be impeded during construction.
 Access roads utilised by the Contractor must be maintained in good condition.

6 Borrow Pits

- Mining authorisations (permits) for borrow pits must be obtained from the Department of Minerals and Energy (DME) in consultation with the Department of Water Affairs (DWA).
- Spoil dumps resulting from borrow pits must not interfere with any natural surface drainage.
- Borrow pits must be rehabilitated after use in accordance with the requirements of DME and DWA.

7 Dust Control / Air Quality

- Dust suppression measures must be implemented during construction by ensuring that all surfaces prone to dust generation are kept damp (e.g. use of water tanker).
- Ensure that vehicles and equipment are in good working conditions and that emissions are not excessive.
- Ensure that vehicles and equipment are in good working conditions and that emissions are not excessive.
- Special care must be taken in areas where the route passes close to schools and residential areas.
- The speed of construction vehicles must be reduced.

8 Fauna

- Contractor staff may not chase, catch or kill animals encountered during construction.

9 Fire Prevention and Control

- Smoking is prohibited in the vicinity of flammable substances.
- The contractor must ensure that fire-fighting equipment is available on site, particularly where flammable substances are being stored or used, and that construction staff are aware of where it is kept and how it is operated.
- Fires started for comfort (warmth) are prohibited, due to the risk of veld fires and risk to adjacent property owner's lands.

10 Grave Sites

- Gravesites in close proximity to the road must not be disturbed during construction.

11 Materials Handling and Spills Management

- Any hazardous materials to be used during construction (e.g. lime, fuel, paint, etc)

BIDDER:

DR. JSMLM:

Initial: Authorized signatory/ies:

1.

Initial: DR. JSMLM

2

Witness:



- are to be stored in a designated area at the campsite.
- The storage containers/facilities (including any diesel/petrol tanks) must be placed on an impermeable surface and surrounded by a bund wall, in order to ensure that accidental spillage does not pollute the environment.
- Workers must at all times be made aware of the health and safety risks associated with any hazardous substances used (e.g. smoking near fuel tanks), and must be provided with appropriate protective clothing/equipment in case of spillages or accidents.
- Ensure all staff and contractors undergo relevant training in the maintenance of equipment to prevent the accidental discharge or spill of fuel, oil, lubricants and other chemicals.
- Any spill of potentially hazardous materials must be cleaned up immediately (Potentially hazardous materials on site include paint, oil, grease, fuel, turpentine, etc).
- The area of contaminated soil or spill must be deposited into the hazardous waste container(s).
- The contractor should keep Peat Sorb or a similar absorbent on site to clean up any spills. The absorbent must be stored in a designated area and be available for inspection.
- All spills are to be recorded in the environmental incident book.

12 Noise

- Noise generating activities must be restricted to between 07h00 and 17h00 Monday to Friday, unless otherwise approved by the appropriate competent person in consultation with adjacent landowners/affected persons.
- All equipment, vehicles and machinery must be in good working condition and be equipped with sound mufflers if necessary.
- Construction staff must be trained and made aware of not creating unnecessary noise such as hooting and shouting.

13 Pollution Control

- Soil and water pollution through usage of fuel, oil, paint, bitumen or other hazardous substances must be avoided.
- All construction vehicles are to be maintained in good working order so as to prevent soil or water pollution from oil, fuel or other leaks, and to reduce noise pollution.

14 Rivers and Streams

- During construction of bridge structures, there must be no obstruction of the water flow of rivers and streams.
- Excavated material must not be stockpiled on or near riverbanks, in order to prevent sedimentation occurring.
- Erosion control measures must be employed both during and after construction.
- No impediments to natural surface water flow, other than approved erosion control measures, must occur.

15 Safety

- Safety measures, such as detour signs, must be implemented during construction to ensure the safety of workers, pedestrians and drivers/passengers in vehicles in the vicinity of construction work.
- Special care must be taken in the vicinity of schools to ensure the safety of children wishing to cross the road under construction.

BIDDER:

DR. JSMLM:

Initial: Authorized signatory/ies:

1.

Initial: DR. JSMLM

2

Witness:



- The relevant signage (e.g. speed control signs) must be erected alongside the road during the operation phase in order to control traffic.
- Accommodation must be made for pedestrian pathways alongside the road during the construction and operation phases.

16 Soil Management

- Stormwater drainage pipes must be installed alongside the road in all areas susceptible to soil erosion.
- Erosion should be minimised by the construction of meadow drains and the planting of indigenous vegetation on the side slopes and drains to reduce flow velocity of stormwater.
- Spoil from cuts may be used in existing erosion galleys.
- Stone pitching and gabions should be constructed at pipe culvert outlets.
- Accidental spills of contaminants onto the ground e.g. oil, concrete, fuel and chemicals should be removed together with the contaminated soil.
- If necessary an absorbent such as Peat Sorb should be used the aid in cleaning up the spill. The contaminated soil should be disposed of in an appropriate container, depending on its classification.
- Servicing and re-fuelling of vehicles must only be carried out at construction camp.

17 Worker Conduct

Code of Conduct for Construction Personnel:

- Do not leave the construction site untidy and strewn with rubbish which will attract animal pests.
- Do not set fires.
- Do not cause any unnecessary, disturbing noise at the construction camp/site or at any designated worker collection/drop off points.
- Do not drive a construction-related vehicle under the influence of alcohol.
- Do not exceed the national speed limits on public roads or exceed the recommended speed limits on the site.
- Do not drive a vehicle which is generating excessive noise or gaseous pollution (noisy vehicles must be reported and repaired as soon as possible).
- Do not litter along the roadsides, including both the public and private roads.
- Do not pollute any water bodies (whether flowing or not).
- No member of the construction team is allowed to enter the areas outside the construction site.

18 Traffic Disturbances and Diversions

- Any traffic diversions must be undertaken with the approval of all relevant authorities and in accordance with all relevant legislation.
- Wherever possible, traffic diversion must only take place on existing disturbed areas and remain within the existing road reserve.
- Traffic diversion routes must be rehabilitated after use.

19 Vegetation

- Only vegetation falling directly on the route must be removed where necessary.
- Alien vegetation within the road reserve must be eradicated, and management measures must be implemented for future control of these species.
- Vegetation that has been removed from large areas (e.g. on traffic diversion routes) during construction must be replaced with indigenous vegetation after construction has been completed.

BIDDER:

DR. JSMLM:

Initial: Authorized signatory/ies:

1.

Initial: DR. JSMLM

2

Witness:



20 Waste Management

- All general, non-hazardous waste must be placed in a skip container and disposed of at a registered waste disposal site.
- The contractor is to ensure that the portable toilet facilities at the campsite are properly maintained and in working order.
- No disposal, or leakage, of sewage must occur on or near the site.
- All hazardous waste (e.g. oil, paint, empty lime bags, contaminated wash water, etc) must be stored in leakproof containers and disposed of at a registered hazardous waste disposal site.
- The contents of waste storage containers must, under no circumstances, be emptied to the surrounding area. In general, littering, discarding or burying of any materials is not allowed on site or along the route.
- Adequate waste receptacles must be available at strategic points around the construction camp and site for all domestic refuse and to minimise the occurrence of littering.
- Concrete rubble must be collected and disposed of as directed by the Project Manager.
- Each working area must be cleared of litter and building waste (e.g. rubble, wood, concrete packets etc) on completion of the day's work.
- Any spill around the container(s) should be treated as per Section C11 and C16.

C3.7.4: PART D: DAYWORKS

This part of the Project Specifications deals with the provision for Dayworks in the Schedule of Quantities. Rates for Dayworks shall be entered in Schedule D of the Schedule of Quantities in accordance with the following specifications.

D.1 SCOPE

Certain work may be carried out using rates tendered in the daywork schedule. A schedule of personnel, plant and equipment which may be necessary to perform work on a daywork basis is included in the schedule of quantities. The quantities used in the schedule are for tender evaluation purposes only and the use or not of these items shall not constitute a variation.

No work will be paid for as Dayworks without the written instruction or approval of the Engineer.

D.2 TYPE OF WORK

The Engineer may order daywork in certain cases where it is necessary to vary or to extend the works due to new or unforeseen circumstances to such an extent that the tendered rates for specific items of work are no longer applicable, or where no suitable combination of tendered rates can be used to pay for such work.

As a general rule, applicable rates for additional work items will be agreed between the Contractor and the Engineer. Dayworks will only be used in exceptional circumstances.

BIDDER:

DR. JSMLM:

Initial: Authorized signatory/ies:

1.

Initial: DR. JSMLM

2

Witness:



D.3 MATERIALS

Materials for use in works carried out under Daywork shall be purchased by the Contractor who shall also arrange for delivery to site, and shall be responsible for any other requirements associated with specific materials. A Provisional Sum has been allowed in Schedule D for Daywork materials. The Contractor shall enter a tendered percentage in the schedule to cover his handling costs and profit, as per other provisional and prime cost sums in this Contract.

Materials shall be paid for using the method described in the Pricing Data. No contract price adjustment will be applicable to materials.

The Contractor shall submit proof of ownership for any materials used in Dayworks with his dayworks claim to the Engineer. Further, if specific materials are required for Dayworks, quotations will be called for.

D.4 CONSTRUCTION PLANT HIRE

Where daywork is ordered, the tendered rates for plant hire in Schedule D shall be used in calculating the payment due for any plant required to execute the daywork. If no rate is included in the schedule for a particular piece of equipment, and where no other rate or combination of rates would provide suitable compensation, then the daywork method of payment described in Clause 37.2.3 of the General Conditions of Contract 2004 edition will be used.

The tendered rates for each item of constructional plant shall include for all operating costs associated with the said item of plant. Such costs are deemed to include fuel, re-fuelling costs, lubrication and routine servicing / maintenance, breakdowns and spares, all overhead costs, site management costs and administration costs. The tendered rates shall also include the plant operator and the general supervision of the plant while it is engaged in the dayworks.

D.5 SALARIES AND WAGES OF WORKMEN

The salaries and wages of workmen executing daywork shall be paid for using the tendered rates in Schedule D which are to be in-line with the current SAFCEC Labor rates including any increases. The tendered rates shall include for all costs associated with the employment of personnel, including salaries, wages, allowances, workmen's compensation, medical aid and pension contributions, Municipality levies and taxes, training costs and any costs associated with living on the site. The tendered rates shall also include for the transportation of the workmen to the site of the dayworks.

All overhead costs, administration costs, site management costs and the Contractor's profit are deemed to be covered by the Dayworks rates and no additions or mark ups will be made to the tendered rates.

The tendered rates shall also include any hand tools normally associated with the workmen's job description e.g. picks, shovels, hammers, saws, spirit levels, etc. The tendered rate for

BIDDER:

DR. JSMLM:

Initial: Authorized signatory/ies:
.....

1.

Initial: DR. JSMLM

2

Witness:



labourers shall also include for the casual supervision by a gang boss or foreman. Only when specifically called for by the Engineer, will payment be made for the use of a gang boss or foreman supervising on a continuous basis.

D.6 MEASUREMENT AND PAYMENT

The following principles shall also apply to the measurement and payment of Dayworks.

The unit of measurement for plant shall be the number of vibroclock hours worked and each item of plant shall be fitted with a vibroclock, the cost of which shall be included in the rates. Excessive non-productive time when the engine is idling will not be paid for. Where there is ambiguity between the flywheel horsepower and mass of the machine, the flywheel horsepower shall govern the measurement category. Where width and mass are specified, mass shall govern the measurement category.

The Contractor's attention is drawn to the requirements of Sub-clauses 37.2.5 and 37.2.6 of the General Conditions of Contract for Construction Work (GCC), 3rd Edition, 2015 with regard to the submission of Dayworks claims.

BIDDER:

DR. JSMLM:

Initial: Authorized signatory/ies:
.....

1.

Initial: DR. JSMLM

2

Witness:



C3.7.5: PART E: OHSA 1993 HEALTH AND SAFETY SPECIFICATION

E1. SCOPE

This specification covers the health and safety requirements to be met by the Contractor to ensure a continued safe and healthy environment for all workers, employees and subcontractors under his control and for all other persons entering the site of works.

This specification shall be read with the Occupational Health and Safety Act (Act No 85 and amendment Act No 181) 1993, and the corresponding Construction Regulations 2003, and all other safety codes and specifications referred to in the said Construction Regulations.

In terms of the OHS Agreement in Section C1.2.4 of the Contract document, the status of the Contractor as mandatory to the Employer (client) is that of an employer in his own right, responsible to comply with all provisions of OHS 1993 and the Construction Regulations 2003.

This safety specification and the Contractor's own Safety Plan as well as the Construction Regulations 2003, shall be displayed on site or made available for inspection by all workers, employees, inspectors and any other persons entering the site of works.

The following are possible risks associated with this project:

- *Working high above the ground on top and below the bridge, most of the time in a restricted environment with limited landings (working platforms)*
- *Working above a continuously flowing river and in an flood plain environment subject to flooding*
- *Lifting and lowering of materials and equipment from the ground to the bridge and vice versa, exposed to cross winds*
- *Steep and restricted access to the lower flood plain below the bridge*
- *Potentially dangerous existing services, i.e. gas lines, water and sewerage mains, electrical high voltage cables, on the bridge, buried and overhead*
- *Deep excavations in soils requiring shoring or reducing of slopes*
- *Blasting of hard rock or demolition of concrete*
- *High pressure during testing of the new rising main, which could result in potentially dangerous situations in the event of the pipeline or fittings failing*
- *Potentially harmful gasses when tying into the existing sewer mains*
- *Movement of construction vehicles on site, taking into consideration steep slopes, other traffic and existing services*
- *Exposure to possible injuries due to mishandling or failure of power and hand tools*
- *Falling debris, tools and materials from bridge*
- *Non-conformance to specifications with regards to fasteners and materials*
- *Risks related to general safety and security on site*

Additional risks may arise from specific methods of construction selected by the Contractor which are not necessary covered in the above.

BIDDER:

DR. JSMLM:

Initial: Authorized signatory/ies:
.....

1.

Initial: DR. JSMLM

2

Witness:



E2. DEFINITIONS

For the purpose of this contract the following shall apply:

- (a) *Employer* where used in the contract documents and in this specification, means the Employer as defined in the General Conditions of Contract and it shall have the exact same meaning as “client” as defined in the Construction Regulations 2003. “Employer” and “client” is therefore interchangeable and shall be read in the context of the relevant document.
- (b) *Contractor* wherever used in the contract documents and in this specification, shall have the same meaning as “Contractor” as defined in the General Conditions of Contract.

In this specification the terms “principal contractor” and “contractor” are replaced with “Contractor” and “subcontractor” respectively.

For the purpose of this contract the Contractor will, in terms of OHS Act 1993, be the mandatory, without derogating from his status as an employer in his own right.

“Engineer” where used in this specification, means the Engineer as defined in the General Conditions of Contract. In terms of the Construction Regulations the Engineer may act as agent on behalf of the Employer (the client as defined in the Construction Regulations).

E3. TENDERS

The Contractor shall submit the following with his tender:

- (a) a documented Health and Safety Plan as stipulated in Regulation 5 of the Construction Regulations. The Safety Plan must be based on the Construction Regulations 2003 and will be subject to approval by the Employer;
- (b) a declaration to the effect that he has the competence and necessary resources to carry out the work safely in compliance with the Construction Regulations 2003;
- (c) a declaration to the effect that he made provision in his tender for the cost of the health and safety measures envisaged in the Construction Regulations.
- (d) Failure to submit the foregoing with his tender, will lead to the conclusion that the Contractor will not be able to carry out the work under the contract safely in accordance with the Construction Regulations.

BIDDER:

DR. JSMLM:

Initial: Authorized signatory/ies:
.....

1.

Initial: DR. JSMLM

2.

Witness:



E4. NOTIFICATION OF COMMENCEMENT OF CONSTRUCTION WORK

After award of the contract, but before commencement of construction work, the Contractor shall, in terms of Regulation 3, notify the Provincial Director of the Department of Labour in writing if the following work is involved:

- (a) the demolition of structures and dismantling of fixed plant of height of 3,0m or more;
- (b) the use of explosives;
- (c) construction work that will exceed 30 days or 300 person-days;
- (d) excavation work deeper than 1,0 m; or
- (e) working at a height greater than 3,0 m above ground or landings.

The notification must be done in the form of the pro forma included under Section 9 (Forms to be Completed by Successful Tenderer) of the tender document.

A copy of the notification form must be kept on site, available for inspection by inspectors, Employer, Engineer, employees and persons on site.

E5. RISK ASSESSMENT

Before commencement of any construction work during the construction period, the Contractor shall have a risk assessment performed and recorded in writing by a competent person. (Refer Regulation 7 of the Construction Regulations 2003).

The risk assessment shall identify and evaluate the risks and hazards that may be expected during the execution of the work under the contract, and it shall include a documented plan of safe work procedures to mitigate, reduce or control the risks and hazards identified.

The risk assessment shall be available on site for inspection by inspectors, Employer, Engineer, subcontractors, employees, trade unions and health and safety committee members, and must be monitored and reviewed periodically by the Contractor.

E6. APPOINTMENT OF EMPLOYEES AND SUBCONTRACTORS

6.1 Health and Safety plan

The Contractor shall appoint his employees and any subcontractors to be employed on the contract, in writing, and he shall provide them with a copy of his documented Health and Safety Plan, or relevant sections thereof. The Contractor shall ensure that all subcontractors and employees are committed to the implementation of his Safety Plan.

6.2 Health and safety induction training

The Contractor shall ensure that all employees under his control, including subcontractors

BIDDER:

DR. JSMLM:

Initial: Authorized signatory/ies:
.....

1.

Initial: DR. JSMLM

2.

Witness:



and their employees, undergo a health and safety induction training course by a competent person before commencement of construction work. No visitor or other person shall be allowed or permitted to enter the site of the works unless such person has undergone health and safety training pertaining to hazards prevalent on site.

The Contractor shall ensure that every employee on site shall at all times be in possession of proof of the health and safety induction training issued by a competent person prior to commencement of construction work.

E7. APPOINTMENT OF SAFETY PERSONNEL

7.1 Construction Supervisor

The Contractor shall appoint a full-time Construction Supervisor with the duty of supervising the performance of the construction work.

He may also have to appoint one or more competent employees to assist the construction supervisor where justified by the scope and complexity of the works.

7.2 Construction safety officer

Taking into consideration the size of the project and the hazards or dangers that can be expected, the Contractor shall appoint in writing a full-time or part-time Construction Safety Officer if so decided by the Inspector of the Department of Labour. The Safety Officer shall have the necessary competence and resources to perform his duties diligently.

Provision shall be made by the Contractor in his rates, to cover the cost of this dedicated construction safety officer appointed after award of the contract.

7.3 Health and safety representatives

In terms of Section 17 and 18 of the Act (OHS Act 1993) the Contractor, being the employer in terms of the Act for the execution of the contract, shall appoint a health and safety representative whenever he has more than 20 employees in his employment on the site of the works. The health and safety representative must be selected from employees who are employed in a full-time capacity at a specific workplace.

The number of health and safety representatives for a workplace shall be at least one for every 100 employees.

The function of health and safety representative(s) will be to review the effectiveness of health and safety measures, to identify potential hazards and major incidents, to examine causes of incidents (in collaboration with his employer, the Contractor), to investigate complaints by employees relating to health and safety at work, to make representations to the employer (Contractor) or inspector on general matters affecting the health and safety of employees, to inspect the workplace, plant, machinery etc. on a regular base, to participate in consultations with inspectors and to attend meetings of the health and safety committee.

BIDDER:	DR. JSMLM:
Initial: Authorized signatory/ies:	1. Initial: DR. JSMLM
	2.
Witness:	



7.4 Health and safety committee

In terms of Sections 17 and 18 of the Act (OHSA 1993) the Contractor (as employer), shall establish one or more health and safety committee(s) where there are two or more health and safety representatives at a workplace. The persons selected by the Contractor to serve on the committee shall be designated in writing.

The function of the health and safety committee shall be to hold meetings at regular intervals, but at least once every three months, to review the health and safety measures on the contract, to discuss incidents related to health and safety with the Contractor and the inspector, and to make recommendations regarding health and safety to the Contractor and to keep record of recommendations and reports made by the committee.

7.5 Competent persons

In accordance with the Construction Regulations the Contractor has to appoint in writing competent persons responsible for supervising construction work on each of the following work situations that may be expected on the site of the works.

- (a) Risk assessment and induction training as described in Regulation 7 of the Construction Regulations;
- (b) Fall protection as described in Regulation 8;
- (c) Formwork and support work as described in Regulation 10;
- (d) Excavation work as described in Regulation 11;
- (e) Demolition work as described in Regulation 12;
- (f) Scaffolding work as described in Regulation 14;
- (g) Suspended platform operations as described in Regulation 15;
- (h) Material hoists as described in Regulation 17;
- (i) Batch plant operations as described in Regulation 18;
- (j) Explosive powered tools as described in Regulation 19;
- (k) Cranes as described in Regulation 20;
- (l) Construction vehicle and mobile plant inspections on a daily basis by a
- (m) competent person as described in Regulation 21(1);
- (n) Control of all temporary electrical installation on the construction site as described in Regulation 22;
- (o) Stacking and storage on construction sites as described in Regulation 26; and
- (p) Inspections of fire equipment as described in Regulation 27.

A competent person may be appointed for more than one part of the construction work with the understanding that the person must be suitably qualified and able to supervise at the same time the construction work on all the work situations for which he has been appointed.

The appointment of competent persons to supervise parts of the construction work does not relieve the Contractor from any of his responsibilities to comply with all requirements of the Construction Regulations.

E8. RECORDS AND REGISTERS

In accordance with the Construction Regulations the Contractor is bound to keep records and registers related to health and safety on site for periodic inspection by inspectors, the Engineer, the Employer, trade union officials and subcontractors and employees. The following records and registers must be kept on site and shall be available for inspection at

BIDDER: **DR. JSMLM:**

Initial: Authorized signatory/ies: **1.** **Initial:** DR. JSMLM

.....

2

Witness:



all times.

- (a) A copy of the OHS Act 1993 Construction Regulations 2003;
- (b) A copy of this Health and Safety Specification;
- (c) A copy of the Contractor's Health and Safety Plan (Regulation 4);
- (d) A copy of the Notification of Construction Work (Regulation 3);
- (e) A health and safety file in terms of Regulation 5(7) with inputs by the Construction Safety Officer (Regulation 6(7));
- (f) A copy of the risk assessment described in Regulation 7;
- (g) A full protection plan and the corresponding records of evaluation and training of employees working from elevated positions as described in Regulation 8;
- (h) Drawings pertaining to the design of structures (Regulation 9(3)) and formwork and support work structures (Regulation 10(d)) must be kept on site;
- (i) Pronouncement of the safety of excavations must be recorded in a register to be kept on site (Regulation 11(3)(h));
- (j) A copy of the certificate of the system design for suspended platforms (Regulation 15(3));
- (k) A notice must be affixed around the base towers of material hoists to indicate the maximum mass load, which may be carried at any one time by material hoists (Regulation 7(5));
- (l) Maintenance records of material hoists and inspection results must be kept in a record book to be kept on site (Regulation 17(8));
- (m) A record of any repairs to or maintenance of a batch plant must be kept on site (Regulations 18(9));
- (n) A warning notice must be displayed in a conspicuous manner when and wherever an explosive powered tool is used (Regulation 19(2));
- (o) A register for recording of findings by the competent person appointed to inspect construction vehicles and mobile plant (Regulation 21(1)(j)).

E9. CONTRACTORS RESPONSIBILITIES

For this contract the Contractor will be the mandatory of the Employer (Client), as defined in the Act (OHS Act 1993), which means that the Contractor has the status of employer in his own right in respect of the contract. The Contractor is therefore responsible for all the duties and obligations of an employer as set out in the Act (OHS Act 1993) and the Construction Regulations 2003.

Before commencement of work under the contract, the Contractor shall enter into an agreement with the Employer (Client) to confirm his status as mandatory (employer) for the contract under consideration.

The Contractor's duties and responsibilities are clearly set out in the Construction Regulations 2003, and are not repeated in detail but some important aspects are highlighted hereafter, without relieving the Contractor of any of his duties and responsibilities in terms of the Construction Regulations.

- (a) Contractor's position in relation to the Employer (Client) (Regulation 4)

In accordance with Section 4 of the Regulations, the Contractor shall liaise closely

BIDDER:

DR. JSMLM:

Initial: Authorized signatory/ies:
.....

1.

Initial: DR. JSMLM

2.

Witness:



with the Employer or the Engineer on behalf of the Employer, to ensure that all requirements of the Act and the Regulations are met and complied with.

(b) *The Principal Contractor and Contractor (Regulation 5)*

The Contractor is in terms of the definition in Regulation 2(b) the equivalent of Principle Contractor as defined in the Construction Regulations, and he shall comply with all the provisions of Regulation 5.

Any subcontractors employed by the Contractor must be appointed in writing, setting out the terms of the appointment in respect of health and safety. An independent subcontractor shall however provide and demonstrate to the Contractor a suitable, acceptable and sufficiently documented health and safety plan before commencement of the subcontract. In the absence of such a health and safety plan the subcontractor shall undertake in writing that he will comply with the Contractor's safety plan, the health and safety specifications of the Employer and the Construction Regulations 2003.

(c) *Supervision of construction work (Regulation 6)*

The Contractor shall appoint the safety and other personnel and employees as required in terms of Regulation 6 and as set out in paragraph 7 above. Appointment of those personnel and employees does not relieve the Contractor from any of the obligations under Regulation 6.

(d) *Risk assessment (Regulation 7)*

The Contractor shall have the risk assessment made as set out in paragraph 7 above before commencement of the work and it must be available on site for inspection at all times. The Contractor shall consult with the health and safety committee or health and safety representative(s) etc. on a regular basis to ensure that all employees, including subcontractors under his control, are informed and trained by a competent person regarding health hazards and related work procedures.

No subcontractor, employee or visitor shall be allowed to enter the site of works without prior health and safety induction training, all as specified in Regulation 7.

(e) *Fall protection (Regulation 8)*

Fall protection, if applicable to this contract shall comply in all respects with Regulation 8 of the Construction Regulations.

(f) *Structures (Regulation 9)*

The Contractor will be liable for all claims arising from collapse or failure of structures if he failed to comply with all the specifications, project specifications and drawings related to the structures, unless it can be proved

that such collapse or failure can be attributed to faulty design or insufficient design standards on which the specifications and the drawings are based.

In addition the Contractor shall comply with all aspects of Regulation 9 of the

BIDDER:

DR. JSMLM:

Initial: Authorized signatory/ies:
.....

1.

Initial: DR. JSMLM

2.

Witness:



Construction Regulations.

(g) Formwork and support work (Regulation 10)

The Contractor will be responsible for the adequate design of all formwork and support structures by a competent person.

All drawings pertaining to formwork shall be kept on site and all equipment and materials used in formwork, shall be carefully examined and checked for suitability by a competent person.

The provisions of Regulation 10 of the Construction Regulations shall be followed in every detail.

(h) Excavation work (Regulation 11)

It is essential that the Contractor shall follow the instructions and precautions in the Standard Specifications and Project Specifications as well as the provisions of the Construction Regulations to the letter as unsafe excavations can be a major hazard on any construction site. The Contractor shall therefore ensure that all excavation work is carried out under the supervision of a competent person, that inspections are carried out by a Professional Engineer or Technologist, and that all work is done in such a manner that no hazards are created by unsafe excavations and working conditions.

Supervision by a competent person will not relieve the Contractor from any of his duties and responsibilities under Regulation 11 of the Construction Regulations.

(i) Demolition work (Regulation 12)

Whenever demolition work is included in a contract, the Contractor shall comply with all the requirements of Regulation 12 of the Construction Regulations. The fact that a competent person has to be appointed by the Contractor does not relieve the Contractor from any of his responsibilities in respect of safety of demolition work.

(j) Tunneling (Regulation 13)

The Contractor shall comply with Regulation 13 wherever tunnelling of any kind is involved.

(k) Scaffolding (Regulation 14)

The Contractor shall ensure that all the provisions of Regulation 14 of the Construction Regulations are complied with. [Note: Reference in the Regulations to "Section 44 of the Act" should read "Section 43 of the Act"].

(l) Suspended platforms (Regulation 15)

Wherever suspended platforms will be necessary on any contract, the Contractor shall ensure that copies of the system design issued by a Professional Engineer are submitted to the Engineer for inspection and approval. The Contractor shall appoint competent persons as supervisors and competent scaffold erectors, operators and

BIDDER:

DR. JSMLM:

Initial: Authorized signatory/ies:
.....

1.

Initial: DR. JSMLM

2

Witness:



inspectors and ensure that all

work related to suspended platforms are done in accordance with Regulation 15 of the Construction Regulations.

(m) Boatswain’s chains (Regulation 16)

Where boatswain’s chains are required on the construction site, the Contractor shall comply with Regulation 16.

(n) Material Hoists (Regulation 17)

Wherever applicable, the Contractor shall comply with the provisions of Regulation 17 to the letter.

(o) Batch plants (Regulation 18)

Wherever applicable, the Contractor shall ensure that all lifting machines, lifting tackle, conveyors, etc. used in the operation of a batch plant shall comply with, and that all operators, supervisors and employees are strictly held to the provisions of Regulation 18. The Contractor shall ensure that the General Safety Regulations (Municipality Notice R1031 of 30 May 1986), the Driven Machinery Regulations (Municipality Notice R295 of 26/2/1988) and the Electrical Installation Regulations (Municipality Notice R2271 of 11/10/1995) are adhered to by all involved.

In terms of the Regulations, records of repairs and maintenance shall be kept on site.

(p) Explosive powered tools (Regulation 19)

The Contractor shall ensure that, wherever explosive-powered tools are required to be used, all safety provisions of Regulation 19 are complied with.

It is especially important that warning notices are displayed and that the issue and return of cartridges and spent cartridges be recorded in a register to be kept on site.

(q) Cranes (Regulation 20)

Wherever the use of tower cranes becomes necessary, the provisions of Regulation 20 shall be complied with.

(r) Construction vehicles And mobile plant (Regulation 21)

The Contractor shall ensure that all construction vehicles and plant are in good working condition and safe for use, and that they are used in accordance with their design and intended use. The vehicles and plant shall only be operated by workers or operators who have received appropriate training, all in accordance with all the requirements of Regulation 21.

All vehicles and plant must be inspected on a daily basis, prior to use, by a competent

BIDDER:

DR. JSMLM:

Initial: Authorized signatory/ies:
.....

1.

Initial: DR. JSMLM

2

Witness:



person and the findings must be recorded in a register to be kept on site.

(s) *Electrical installation and machinery on construction sites (Regulation 22)*

The Contractor shall comply with the Electrical Installation Regulations (Municipality Notice R2920 of 23 October 1992) and the Electrical Machinery Regulations (Municipality Notice R1953 of 12 August 1993). Before commencement of construction, the Contractor shall take adequate steps to

ascertain the presence of, and guard against dangers and hazards due to electrical cables and apparatus under, over or on the site.

All temporary electrical installations on the site shall be under the control of a competent person, without relieving the Contractor of his responsibility for the health and safety of all workers and persons on site in terms of Regulation 22.

(t) *Use of temporary storage of flammable liquids on construction sites (Regulation 23)*

The Contractor shall comply with the provisions of the General Safety Regulations (Municipality Notice R1031 of 30 May 1986) and all the provisions of Regulation 23 of the Construction Regulations to ensure a safe and hazard-free environment to all workers and other persons on site.

(u) *Water environments (Regulation 24)*

Where construction work is done over or in close proximity to water, the provisions of Regulation 24 shall apply.

(v) *Housekeeping on Construction sites (Regulation 25)*

Housekeeping on all construction sites shall be in accordance with the provisions of the environment Regulations for workplaces (Municipality Notice R2281 of 16 October 1987) and all the provisions of Regulation 25 of the Construction Regulations.

(w) *Stacking and storage on construction sites (Regulation 26)*

The provisions for the stacking of articles contained in the General Safety Regulations (Municipality Notice R1031 of 30 May 1986) as well as all the provisions Regulation 26 of the Construction Regulations shall apply.

(x) *Fire precautions on construction sites (Regulation 27)*

The provisions of the Environmental Regulations for Workplaces (Municipality Notice R 2281 of 16 October 1987) shall apply.

In addition the necessary precautions shall be taken to prevent the incidence of fires, to provide adequate and sufficient fire protection equipment, sirens, escape routes etc. all in accordance with Regulation 27 of the Construction Regulations.

(y) *Construction welfare facilities (Regulation 28)*

The Contractor shall comply with the construction site provisions as in the Facilities

BIDDER:

DR. JSMLM:

Initial: Authorized signatory/ies:
.....

1.

Initial: DR. JSMLM

2

Witness:



Regulations (Municipality Notice R1593 of 12 August 1988) and the provisions of Regulation 28 of the Construction Regulations.

(z) *Non-compliance with the Construction Regulations 2003*

The foregoing is a summary of parts of the Construction Regulations applicable to all construction projects.

The Contractor, as employer for the execution of the contract, shall ensure that all provisions of the Construction Regulations applicable to the contract under consideration are complied with to the letter.

Should the Contractor fail to comply with the provisions of the Regulations 3 to 28 as listed in Regulation 30, he will be guilty of an offence and will be liable, upon conviction, to the fines or imprisonment as set out in Regulation 30. The Contractor is advised in his own interest to make a careful study of the Act and the Construction Regulations as ignorance of the Act and the Regulations will not be accepted in any proceedings related to non-conformance to the Act and the Regulations.

E10. MEASUREMENT AND PAYMENT

10.1 Principles

It is a condition of this contract that Contractors, who submit tenders for this contract, shall make provision in their tenders for the cost of all health and safety measures during the construction process. All associated activities and expenditure are deemed to be included in the Contractor's tendered rates and prices.

(a) *Safety personnel*

The Construction Supervisor, the Construction Safety Officer, Health and Safety Representatives, Health and Safety Committee and Competent Persons shall be members of the Contractor's personnel, and no additional payment will be made for the appointment of such safety personnel.

(b) *Records and Registers*

The keeping of health and safety-related records and registers as described in 8 is regarded as a normal duty of the Contractor for which no additional payment will be considered, and which is deemed to be included in the Contractor's tendered rates and prices.

BIDDER:

DR. JSMLM:

Initial: Authorized signatory/ies:
.....

1.

Initial: DR. JSMLM

2

Witness:



Risk and Quality Management Plan:

1. Risk Identification:

- a) Weather conditions: Mitigation measures include tracking weather forecasts and scheduling construction activities accordingly.
- b) Soil instability: Actions involve conducting soil tests, implementing stabilization techniques, and ensuring proper compaction.
- c) Borrow pit permission issues: This risk can be mitigated by obtaining necessary permits in advance and exploring alternative sources.
- d) Community unrest: Close collaboration with the community, effective communication, and addressing their concerns proactively can help manage this risk.
- e) Insufficient drainage with Hydroseeding: Ensuring proper design and implementation of hydroseeding earth drains and monitoring their effectiveness.

2. Risk Assessment and Prioritization:

- a) Likelihood and impact: Assess the likelihood and impact of each risk on a scale of high, medium, and low.
- b) Critical risks: Identify risks critical to the success of the project.
- c) Immediate attention: Prioritize risks that require immediate mitigation measures, such as community issues.

3. Risk Mitigation and Response:

- a) Community and social facilitation: Engage with the community, address concerns, and involve them in labor-intensive activities to foster positive relations.
- b) Responsibility: All stakeholders (Municipality, Contractor, Consultant) should be responsible for implementing risk mitigation measures.
- c) Documentation and communication: Risk response plans should be documented in a comprehensive manner, including the identified risks, mitigation measures, responsibilities, and timelines. This documentation should be communicated to all relevant stakeholders to ensure everyone is aware of the plan.

4. Quality Control:

- a) Quality standards and specifications: The construction of the Concrete Block Paving should adhere to specified layer-works, compaction levels, and hydroseeding requirements, as outlined in the project specifications.
- b) Monitoring and assessment: Regular inspections by the Contractor, Consultant, and Employer's Agent should be conducted to ensure compliance with quality standards. Inspection requests should be issued for each completed task, and any deviations or defects should be addressed promptly.

BIDDER:

DR. JSMLM:

Initial: Authorized signatory/ies:
.....

1.

Initial: DR. JSMLM

2

Witness:



5. Quality Assurance:

- a) Compliance assurance: No approval should be issued for works not inspected, and all defects or deviations from specifications should be rectified.
- b) Reporting and rectification: The Engineer should keep records of methods used for each task and issue instructions for rectifying any identified defects or deviations.

6. Resource Planning:

- a) Resource identification and procurement: Ensure that the necessary equipment (such as excavator, grader, roller), materials, and skilled labor have been identified and procured for the project.
- b) Risk assessment: Continuously assess the availability and reliability of resources, identifying any potential risks, and have contingency plans in place to address them.

7. Communication and Reporting:

- a) Communication channels: Formal communication among project team members, stakeholders, and contractors should be facilitated through the Consultant, who acts as the Employer's Agent.
- b) Reporting mechanisms: Regular progress reports, both weekly and monthly, should be provided to update stakeholders about risk and quality management activities.

8. Training and Competency:

- a) Skilled labour: The contractor should ensure that the project team members and contractors possess the necessary skills and knowledge to meet the project's quality requirements. Additional on-the-job training may be provided, if needed.
- b) Entrepreneur skills training: The contractor should provide formal entrepreneur skills training to local residents, empowering them to improve their small construction-related businesses.

9. Documentation and Record-Keeping:

- a) Project documentation management: Design specifications, quality checklists, risk registers, audit reports, and other relevant documents should be managed and maintained. Files should be kept on-site, with copies available at the Employer's Agent's office.

10. Contingency Planning:

- a) Contingency fund allocation: Allocate 10% of the project construction cost for unforeseen circumstances and changes crucial to the project's successful completion.

BIDDER:		DR. JSMLM:
Initial: Authorized signatory/ies:	1.	Initial: DR. JSMLM
	2	
Witness:		



b) Crisis management: Have a plan in place to address potential disruptions, delays, or changes that may impact the project timeline and quality. Thorough record-keeping and investigation into any issues should guide the response.

11. Continuous Improvement:

a) Feedback and lessons learned: Establish a process to collect feedback and lessons learned throughout the project. Regular report writing and updates to the site diary can facilitate this process.

12. Review and Monitoring:

- a) Frequency of review: The Risk and Quality Management plan should be reviewed on a weekly basis to track progress and identify any necessary updates.
- b) Responsibility for oversight: The Site Agent and Resident Engineer should be responsible for overseeing and monitoring the implementation of the plan.
- c) Key performance indicators: Consider establishing key performance indicators (KPIs) or milestones to track progress, ensure compliance with the plan, and measure the overall success of the project.

This comprehensive Risk and Quality Management Plan outlines the necessary steps, responsibilities, and mitigation measures to ensure the successful construction of the Concrete Block Paving. It considers risks associated with weather conditions, soil instability, community concerns, and other factors. Quality control measures, resource planning, communication protocols, and continuous improvement strategies are also outlined. Regular review, monitoring, and documentation will help ensure compliance with quality standards and address any potential risks or issues that may arise throughout the project.

<u>BIDDER:</u>		<u>DR. JSMLM:</u>
Initial: Authorized signatory/ies:	1.	Initial: DR. JSMLM
	2	
Witness:		



DR JS MOROKA LOCAL MUNICIPALITY



**CONTRACT NO: JSM R02/25-26/W27: CONSTRUCTION OF KATJIBANE BUS AND TAXI
ROUTE PHASE-5**

C4 SITE INFORMATION

- C4.1 CONDITIONS ON SITE: GEOTECHNICAL REPORT
- C4.2 EXISTING SERVICES REPORT

BIDDER:

DR. JSMLM:

Initial: Authorized signatory/ies:
.....

1.

Initial: DR. JSMLM

2

Witness:



C4.1 CONDITIONS ON SITE: GEOTECHNICAL REPORT

4.1 Soil types and method of treatment:

The soil profile of the centerline soil survey undertaken along the entire project road to a depth of 1.0m indicated **unsuitable** material that require cut to spoil down to roadbed level.

The following sequential procedure can be used for the roadbed preparation and construction of pavement layers:

- Excavate and remove the in-situ unsuitable material to a depth of 300 mm and even 450 mm (above roadbed level).
- Scarify the in-situ to a depth of 150mm and then mix and compact to 89% of the Modified AASHTO.
- Introduce the borrow pit material and compact to 93% of the modified AASHTO as Road bed layer.
- Place the same borrow pit material and compact to 95% of the modified AASHTO as subbase layer.
- Finally, import G6/7 quality material that will require cement stabilization to achieve C4 and compact to at least 97% of the modified AASHTO maximum Dry Density at optimum moisture content + or – 1%.

Results obtained from the field investigations carried out on the project road, indicate that;

- Most of the materials are unsuitable for road construction in their current state.
- Basing on these findings, we conclude that most the in-situ soils should be cut to spoil.

BIDDER:

DR. JSMLM:

Initial: Authorized signatory/ies:
.....

1.

Initial: DR. JSMLM

2

Witness:

C4.2 EXISTING SERVICES REPORT

All known services will be shown to the tenderers and others will be exposed during construction.

BIDDER:

DR. JSMLM:

Initial: Authorized signatory/ies:
.....

1.

Initial: DR. JSMLM

2

Witness:



DR JS MOROKA LOCAL MUNICIPALITY



CONTRACT NO: JSM R02/25-26/W27: CONSTRUCTION OF KATJIBANE BUS AND TAXI ROUTE PHASE-5

C5: ADDITIONAL RELEVANT DOCUMENTATION

C5.1 Dr JS Moroka Local Municipality Supply Chain Management Policy.

C5.2 The preferential procurement policy framework Act, 2000: preferential procurement regulations, 2022 including any other amendments made thereafter and including the following:

C5.3 DRJSMLM health and safety specifications

C5.4 Guidelines for the Implementation of Labour-Intensive Infrastructure projects under the Expanded Public Works Programme (EPWP)

C5.5. Photo Record and site Locality

C5.6. Tender Drawings

C5.7. Name Board

C5.8. Environmental Checklist/ Penalties

BIDDER:

DR. JSMLM:

Initial: Authorized signatory/ies: 1. **Initial:** DR. JSMLM

2

Witness:.....

DR JS MOROKA LOCAL MUNICIPALITY



CONTRACT NO: *JSM R02/25-26/W27.*
CONSTRUCTION OF KATJIBANE BUS AND TAXI ROUTE PHASE-5

C6: TENDER DRAWINGS

The following drawings are attached in this Tender document:

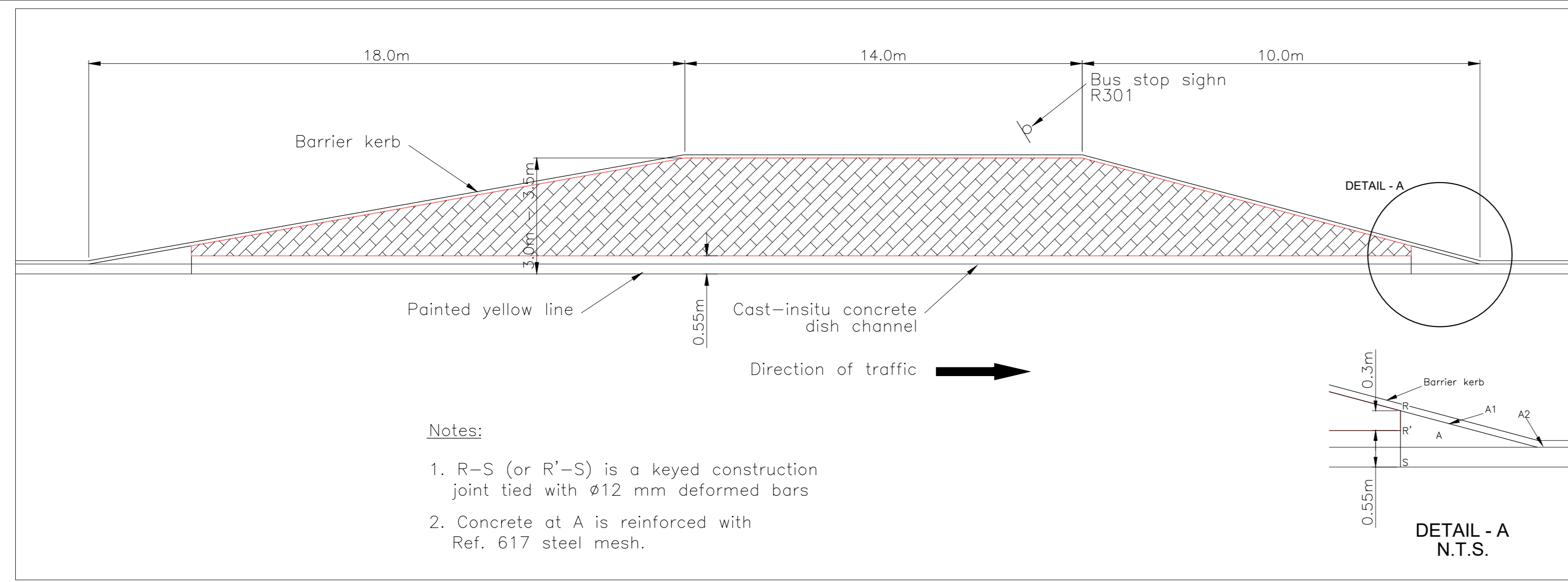

GEOMETRICAL LAYOUT OF BUS BAY FOR SINGLE BUS - USING CAST-IN SITU DISH CHANNEL
SCALE - 1: 100

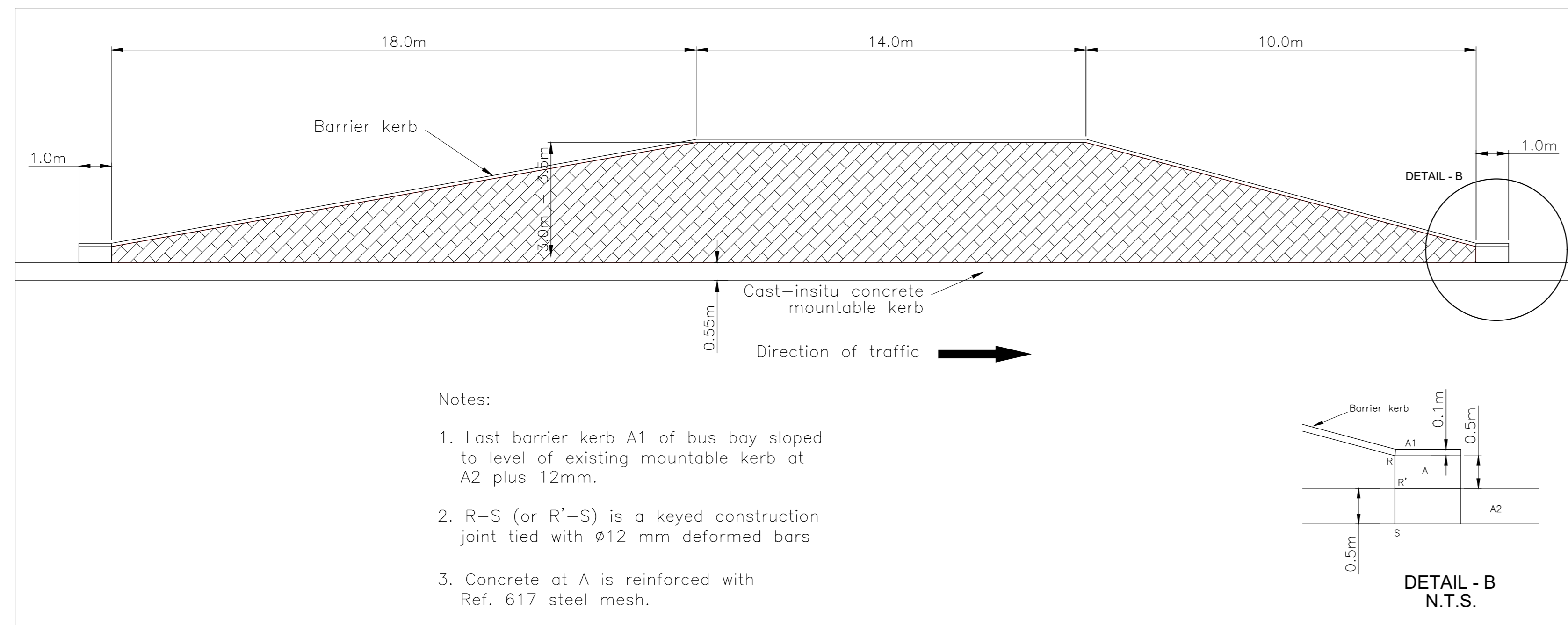

GEOMETRICAL LAYOUT OF BUS BAY FOR SINGLE BUS - USING CAST-IN SITU MOUNTABLE KERB
SCALE - 1: 100

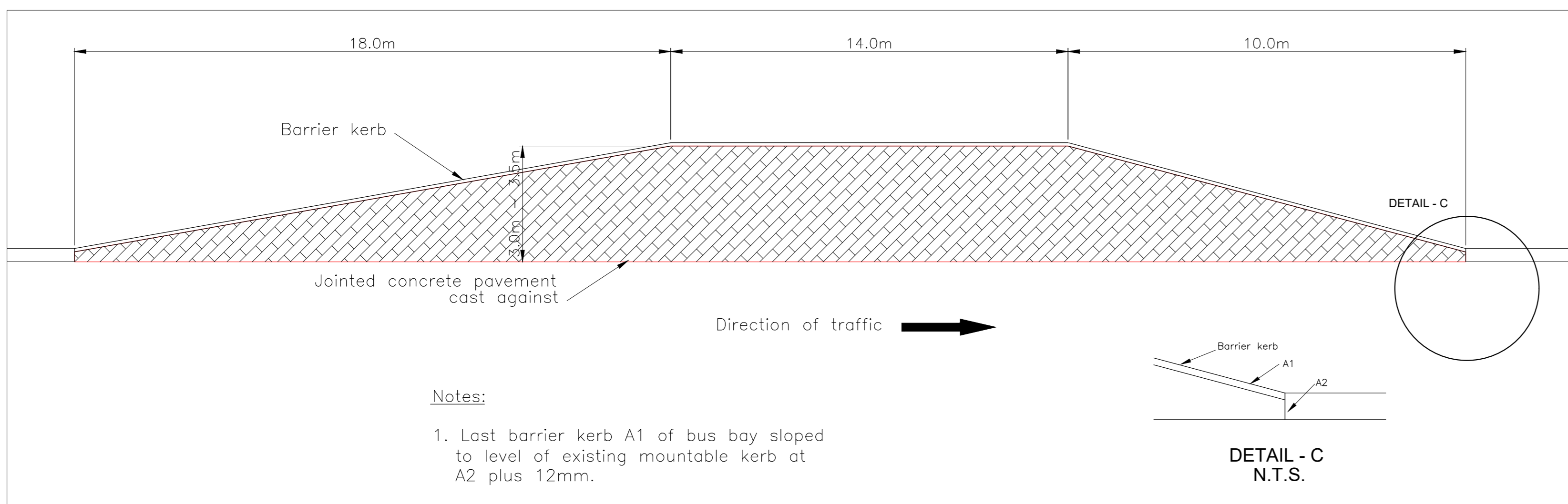

GEOMETRICAL LAYOUT OF BUS BAY FOR SINGLE BUS - USING JOINTED PAVEMENT
SCALE - 1: 100

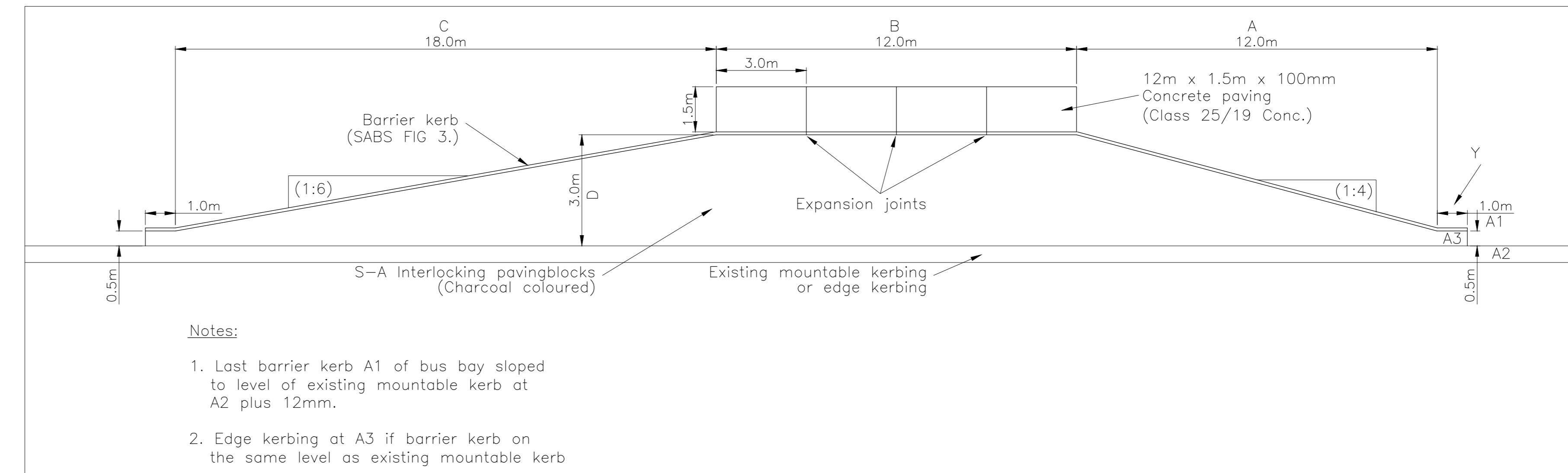
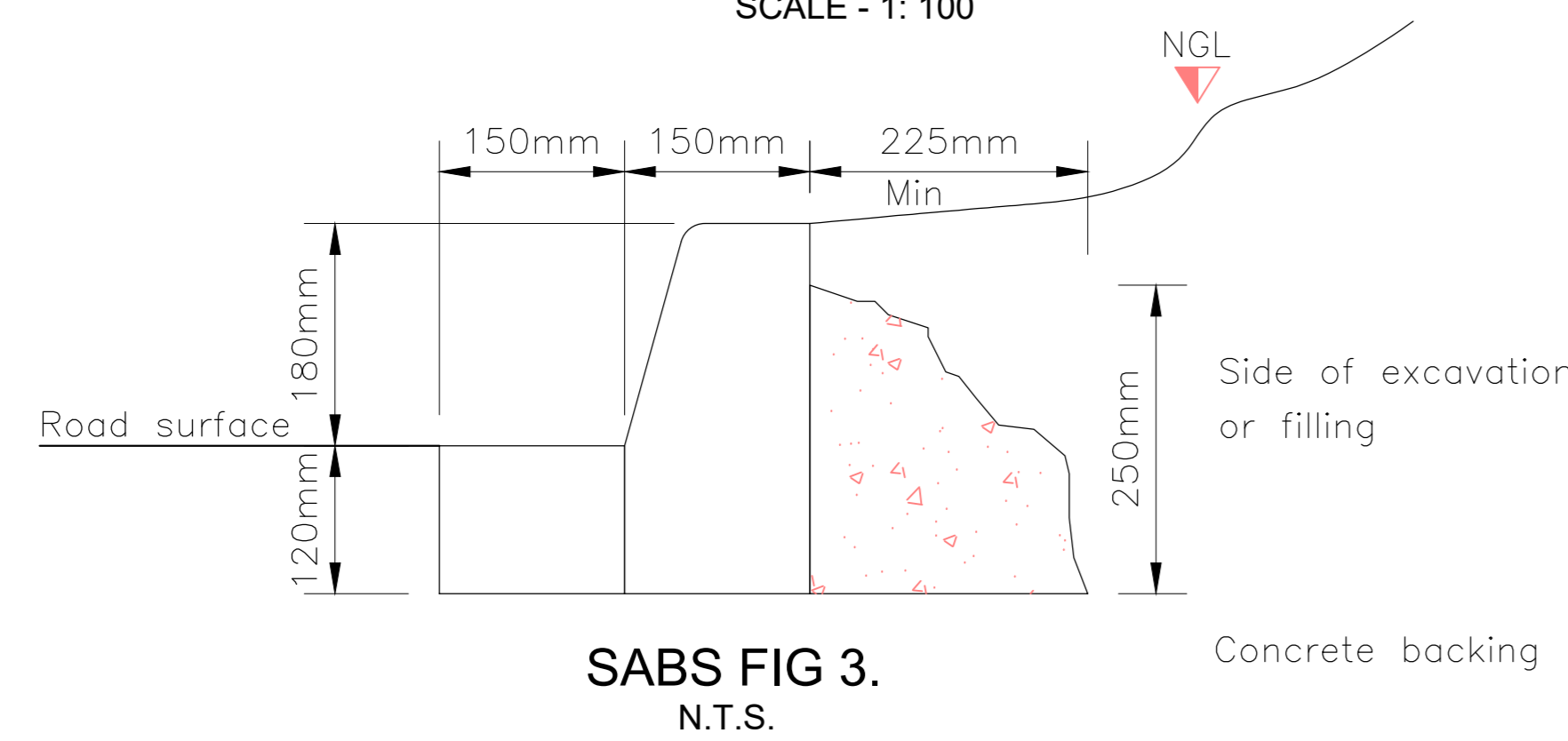

LAYOUT PLAN OF TYPICAL BUS BAY
SCALE - 1: 150

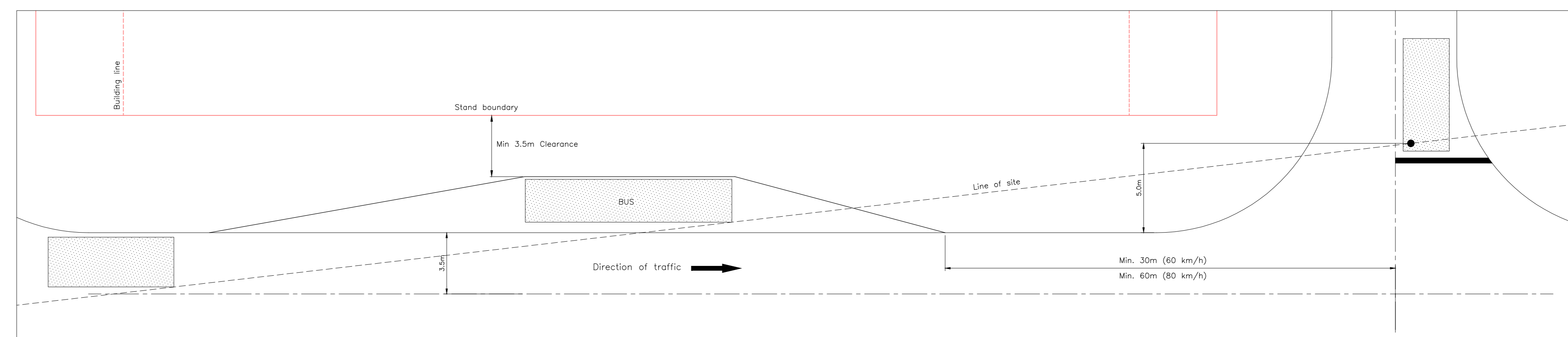

ACCESS ADJACENT TO BUS/TAXI BAY
SCALE - 1: 150

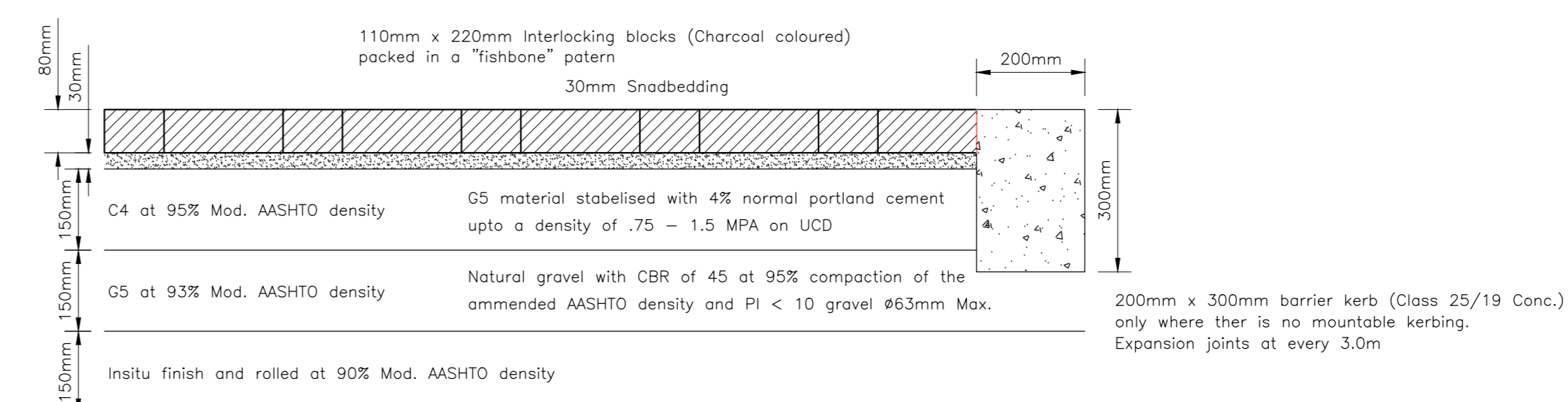

LAYER WORK DETAIL
N.T.S.

NOTES

- On straight sections of 1.0m long a concrete backing of 400mm x 250mm x 225mm should be added behind every joint.(Class 25/19 conc.)
- At arched sections of kerbing a continuous concrete backing 250mm x 225mm x dist. must be added. (Class 25/19 Conc.)
- At every kerbing joint of 10mm a 1:3 grout filling should be applied. And an open joint at every 3.0m.
- 12.0m x 1.5m x 0.1m concrete paving should be in 3.0m sections, with a bitumen joint.
- If no mountable kerbing at road edge is found a 200mm x 300mm in situ barrier kerb should be casted as shown on layer works detail.
- Cross fall shall be determined on site.
- Fill material behind bus bay should be at 90% Mod. AASHTO density.
- Section A, B, C & D is changable and should be determined on each site. The dimensions on this drawing is for the most common case scenario.

MORULA CONSULTING ENGINEERS



CONSULTING ENGINEERS & PROJECT MANAGERS
"a new dawn"

P.o.Box 2740
POLOKWANE
0007

Tel: (015)291-1161
Fax: (086) 558-6446



A2601/3 Bongimfundo Street
Siyabuswa

Tel: (013) 973 1101/0821
Fax: (013) 973 2463/0973
Email: info@moroka.gov.za

AMENDMENTS

No.	AS BUILT RECORDED	ISSUED FOR APPROVAL	BY	APPROVED	DATE
02			H.T	H.T	02/03/2025
03					16/02/2025

APPROVED ON BEHALF OF THE CONSULTING ENGINEER

ENGINEER: _____
REG. No.: _____
DATE: _____
SIGNATURE: _____

REFERENCE

DESIGNED

DRAWN
REVIEWED
PROJECT ENGINEER

Project No: JSM / R02 / 25-26W27

KATJIBANE BUS AND TAXI ROUTE (PHASE 4)

BUS BAY DETAILS

CONTRACT:
DATE: 05-2025

DRAWING
ML/JS3/STD-06

REVISION
0

ROAD SETTING OUT DATA							Lo 27	
PI No.	CH	YLo	XLo	Radius	DA	TL	AL	
Const:				(m)	D M S	(m)	(m)	
PI 26		37089.385	2766746.651	1	91°54'18"	1.034	1.604	
EC 26	765.080	37089.885	2766747.555					
BC 27	821.415	37117.126	2766796.867					
PI 27		37129.506	2766819.277	50	54°13'49"	25.603	47.325	
EC 27	868.740	37118.559	2766842.422					
BC 28	1230.814	36963.750	2767169.732					
PI 28		36928.565	2767244.124	500	18°41'33"	82.292	163.123	
EC 28	1393.937	36871.394	2767303.314					
BC 29	1536.810	36772.137	2767406.079					
PI 29		36725.988	2767453.859	400	18°51'29"	66.428	131.654	
EC 29	1668.464	36697.759	2767513.990					
BC 30	2332.352	36415.641	2768114.954					
PI 30		36415.041	2768116.232	1000	0°09'43"	1.412	2.824	
EC 30	2335.177	36414.445	2768117.513					
BC 31	2569.361	36315.528	2768329.781					
PI 31		36299.484	2768364.210	1000	4°21'02"	37.984	75.931	
EC 31	2645.292	36286.098	2768399.757					
PI 32		2708.930	2768459.312					

BENCHMARK LIST WG:LO29				
BM1	36255.743	2768462.045	1008.811	KERB
BM2	36447.967	2768101.230	1010.392	12MM CONC
BM3	36545.599	2767780.292	1010.868	12MM CONC
BM4	36755.304	2767471.218	1011.130	12MM CONC
BM5	36935.887	2767165.321	1012.444	12MM CONC
BM6	37128.992	2766806.947	1013.083	12MM CONC

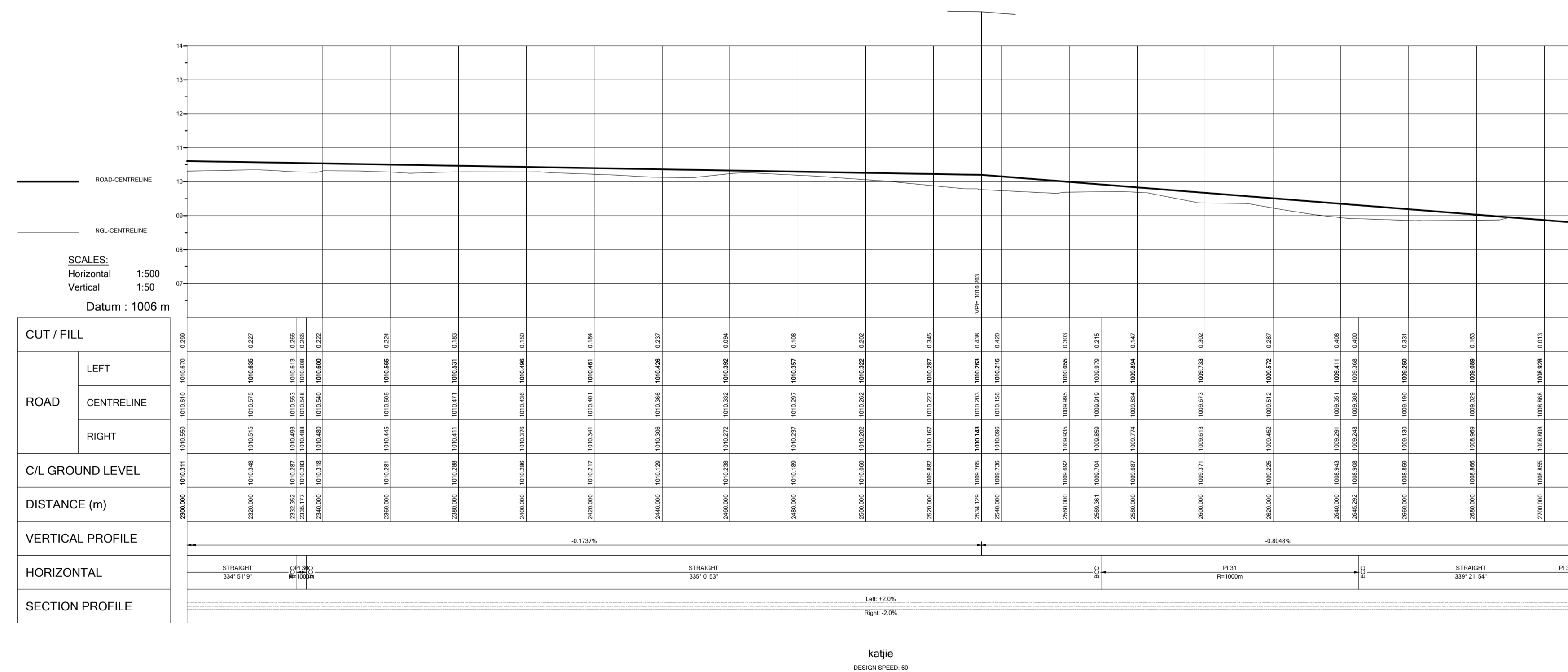
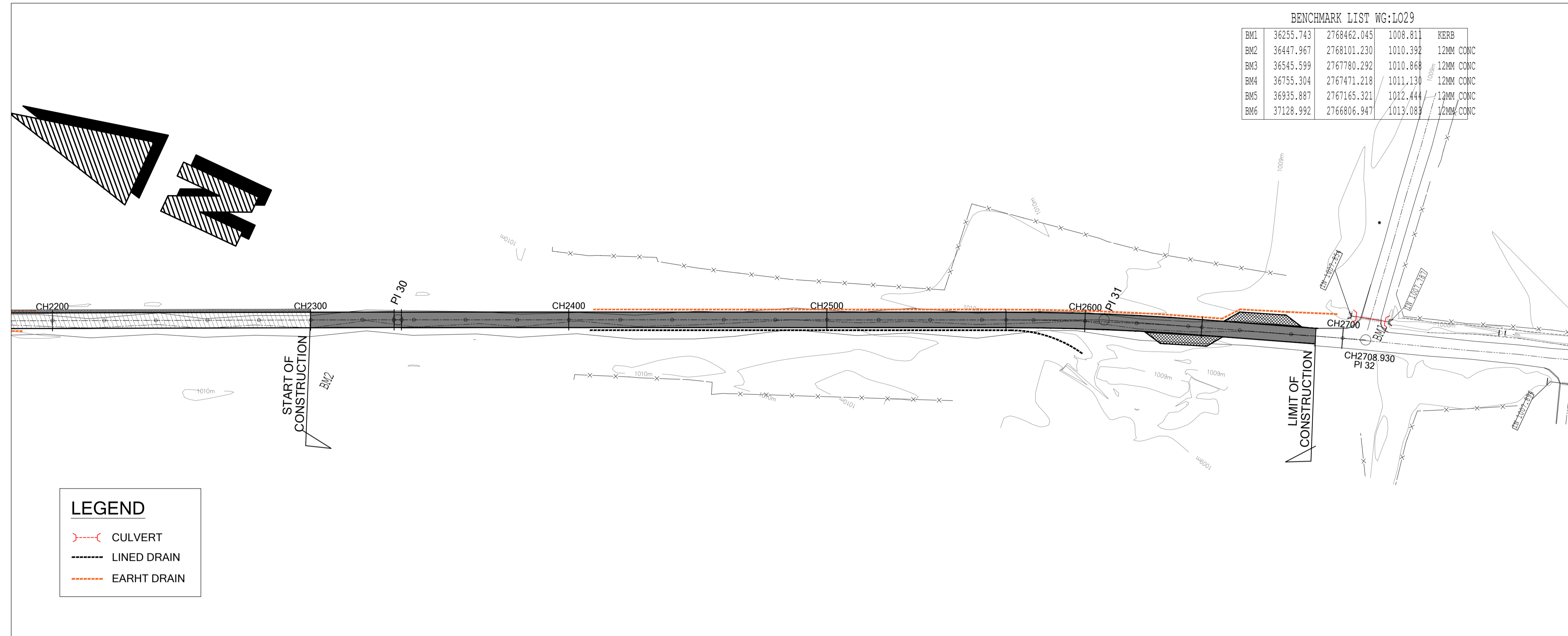

MORULA CONSULTING ENGINEERS
 P.o.Box 2740
 POLOKWANE
 0007
 Tel: (015)291-1161
 Fax: (086) 558-6446

dr.jsmmlm
 A2601/3 Bongimfundo Street
 Siyabuswa
 Tel: (013) 973 1101/0821
 Fax: (013) 973 2463/0973
 Email: info@moroka.gov.za

AMENDMENTS	BY	APPROVED	DATE
01 AS BUILT RECORDS ISSUED FOR APPROVAL			05/2025

APPROVED ON BEHALF OF THE CONSULTING ENGINEER
 ENGINEER: _____
 REG. No.: _____
 DATE: _____
 SIGNATURE: _____

REFERENCE

DESIGNED
 DRAWN
 REVIEWED
 PROJECT ENGINEER

CONTRACT: _____
 DATE: 05-2025

Project No: JSM / R02 / 25-26W27
KATJIBANE BUS AND TAXI ROUTE (PHASE 4)
LAYOUT AND LONG SECTION
 DRAWING: ML-JS3-LS1
 REVISION: 0

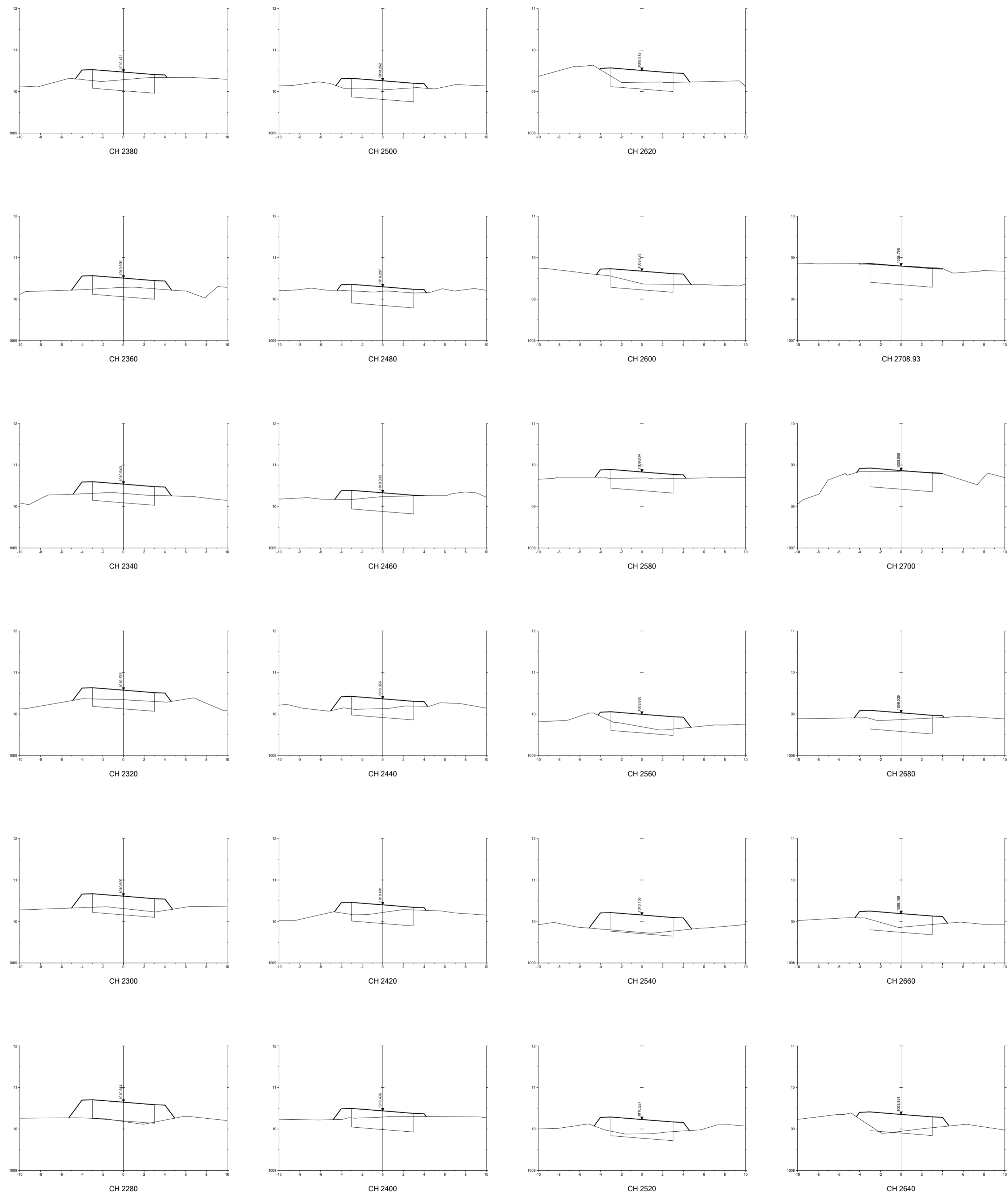

MORULA CONSULTING ENGINEERS



P.o.Box 2740
 POLOKWANE
 0007
 Tel: (015)291-1161
 Fax: (086) 558-6446



A2601/3 Bongimfundo Street
 Siyabuswa
 Tel: (013) 973 1101/0821
 Fax: (013) 973 2463/0973
 Email: info@moroka.gov.za

No	AMENDMENTS	BY	APPROVED	DATE
01	AS BUILT RECORD	HT	HT	05/2025
02	ISSUED FOR APPROVAL	HT	HT	05/2025

H-SCALE 1: 100
 V-SCALE 1: 25

APPROVED ON BEHALF OF THE CONSULTING ENGINEER
 ENGINEER : _____
 REG. No. : _____
 DATE : _____
 SIGNATURE : _____

REFERENCE

DESIGNED
 DRAWN
 REVIEWED
 PROJECT ENGINEER

Project No: JSM / R02 / 25-26W27
KATJIBANE BUS AND TAXI ROUTE (PHASE 4)
CROSS SECTIONS
 CONTRACT: _____
 DATE: 05-2025
 DRAWING: ML-JS3-XS1
 REVISION: 0

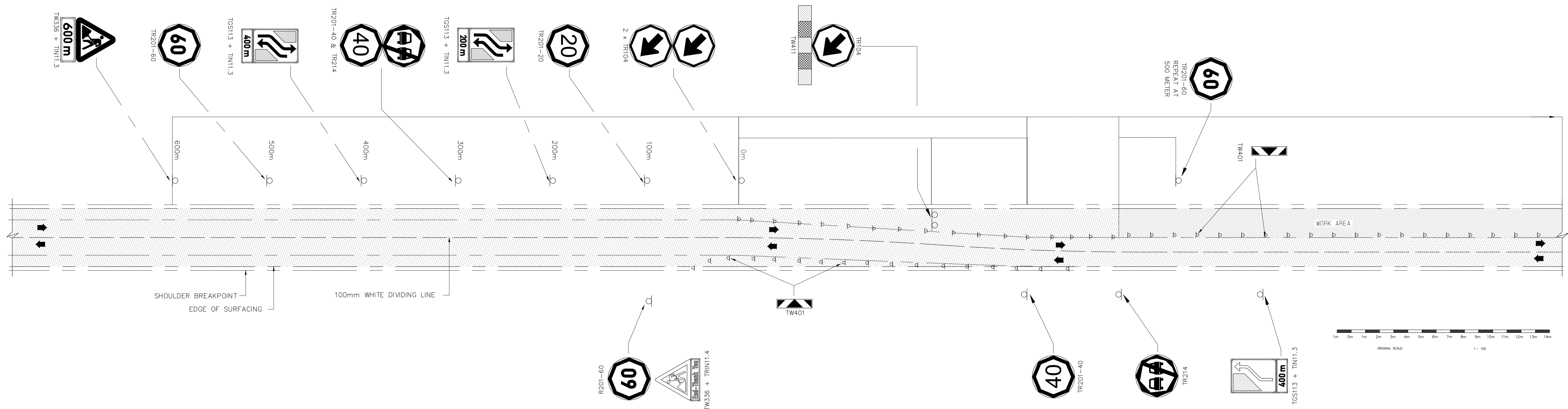

TYPICAL ROAD SIGN SEQUENCE FOR HALF-WIDTH CONSTRUCTION

N.T.S

MORULA CONSULTING ENGINEERS



P.o.Box 2740
 POLOKWANE
 0007
 Tel: (015)291-1161
 Fax: (086) 558-6446



A2601/3 Bongimfundo Street
 Siyabuswa
 Tel: (013) 973 1101/0821
 Fax: (013) 973 2463/0973
 Email: info@moroka.gov.za

NO	AMENDMENTS	BY	APPROVED	DATE
01	AS BUILT RECORD	HT	HT	02/03/20
02	ISSUED FOR APPROVAL			09/02/25

APPROVED ON BEHALF OF THE CONSULTING ENGINEER
 ENGINEER: _____
 REG. No: _____
 DATE: _____
 SIGNATURE: _____

REFERENCE

DESIGNED
 DRAWN
 REVIEWED
 PROJECT ENGINEER

Project No: JSM / R02 / 25-26W27
 KATJIBANE BUS AND TAXI ROUTE (PHASE 4)
 ACCOMMODATION OF TRAFFIC DETAILS
 CONTRACT: _____
 DATE: 05-2025
 DRAWING: ML/JS3/STD-05
 REVISION: 0

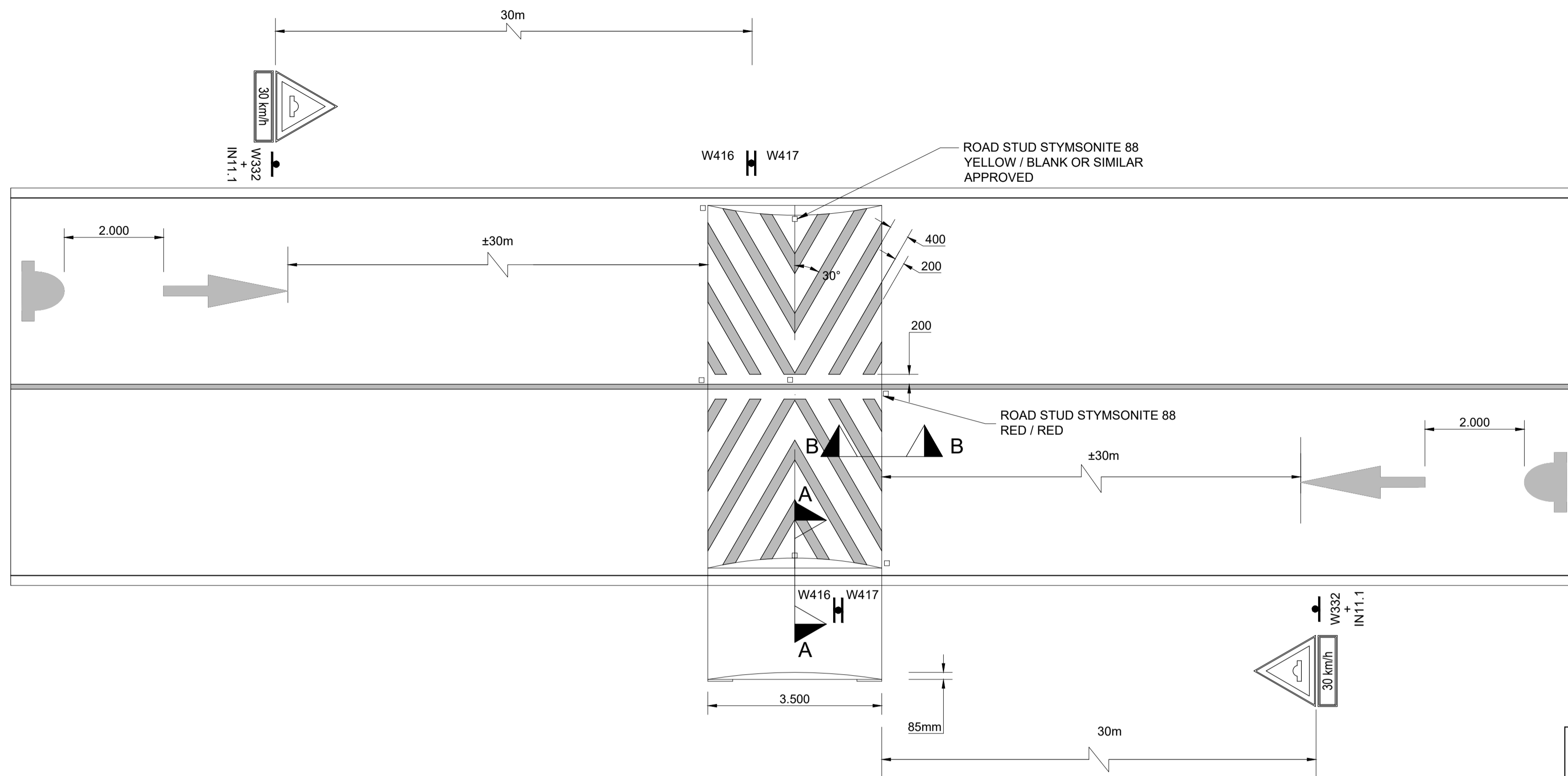

PLAN OF SPEED HUMP
SCALE 1:100

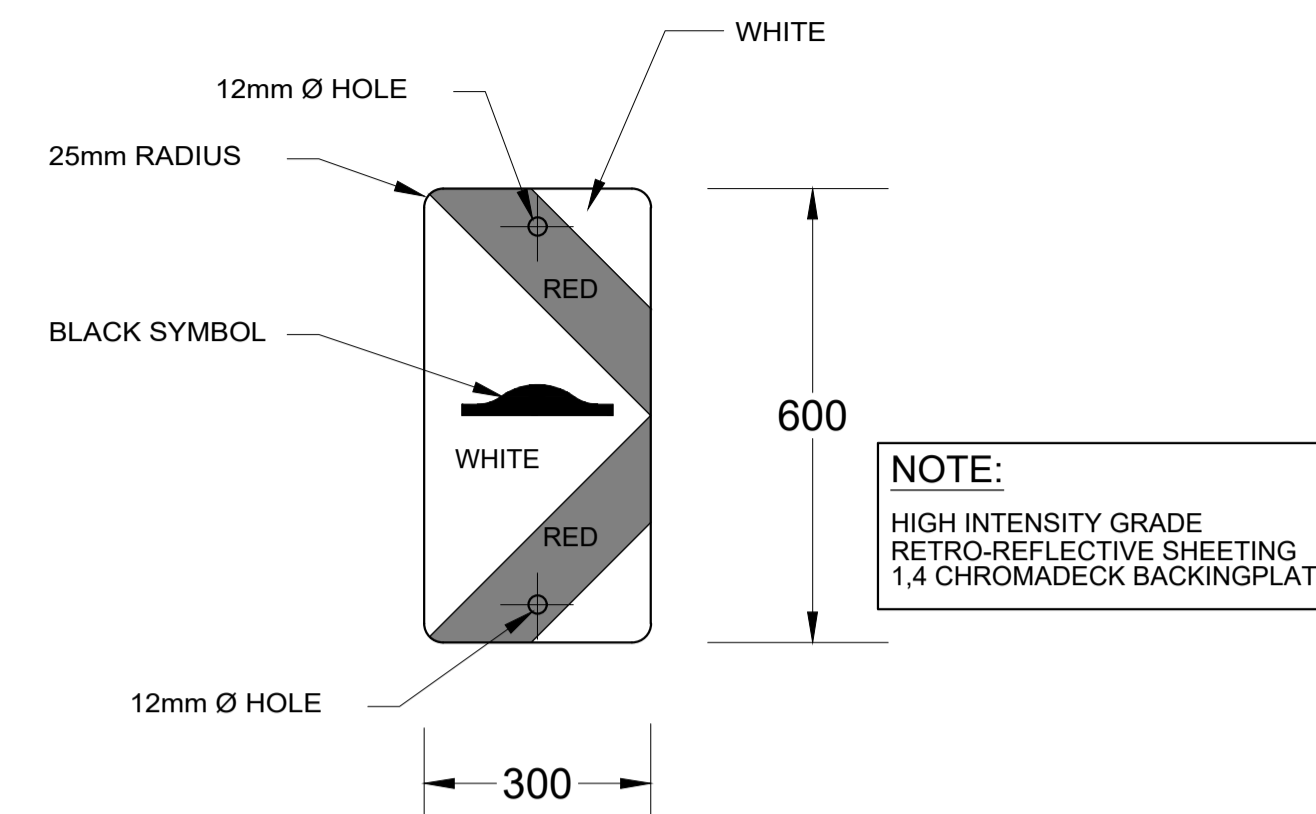

DANGER PLATE SPEEDHUMP (LEFT)
W416
SCALE 1:10

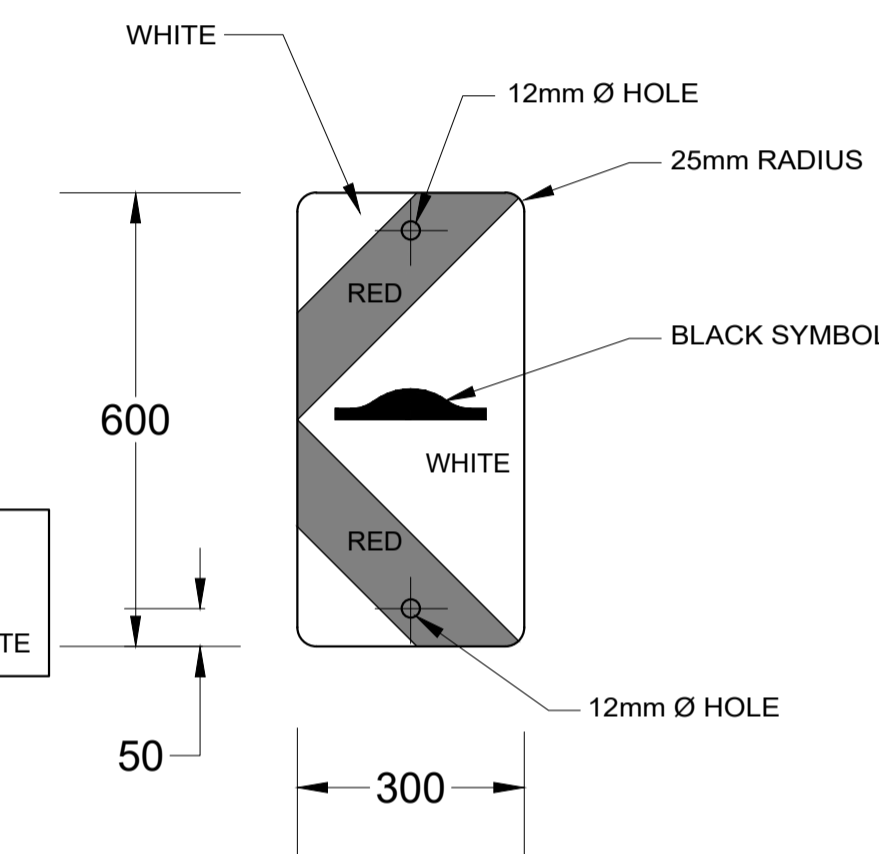

DANGER PLATE SPEEDHUMP (RIGHT)
W417
SCALE 1:10

NOTES

CONSTRUCTION METHOD:

1. Setting out of hump - few days before construction.
 2. Saw cuts one to two days before construction.
- ON CONSTRUCTION DAY:**
3. Remove 500 mm asphalt strips.
 4. Start erecting road signs and paint warning road marking.
 5. Place asphalt in strips and compact with two passes without vibrator.
 6. Place templates - both sides of one lane at a time.
 7. Place asphalt and rake till slightly higher than templates.
 8. Shape asphalt with straight edge (channel section 6 m long).
 9. Remove templates and compact without vibrator (three passes)
 10. Measure profile and rectify if necessary.
 11. Final compaction with three to four passes with vibrator.
 12. Place road studs.
 13. Paint speed hump the next day.

NOTE:
HIGH INTENSITY GRADE
RETRO-REFLECTIVE SHEETING
1,4 CHROMADECK BACKINGPLATE

NOTE:
HIGH INTENSITY GRADE
RETRO-REFLECTIVE SHEETING
1,4 CHROMADECK BACKINGPLATE

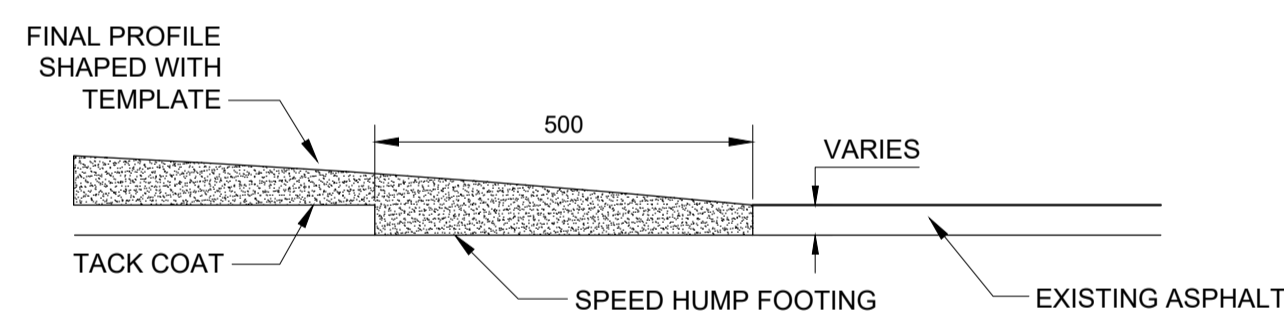

**SECTION A-A:
CONSTRUCTION DETAIL OF SPEED HUMP**
SCALE 1: 100

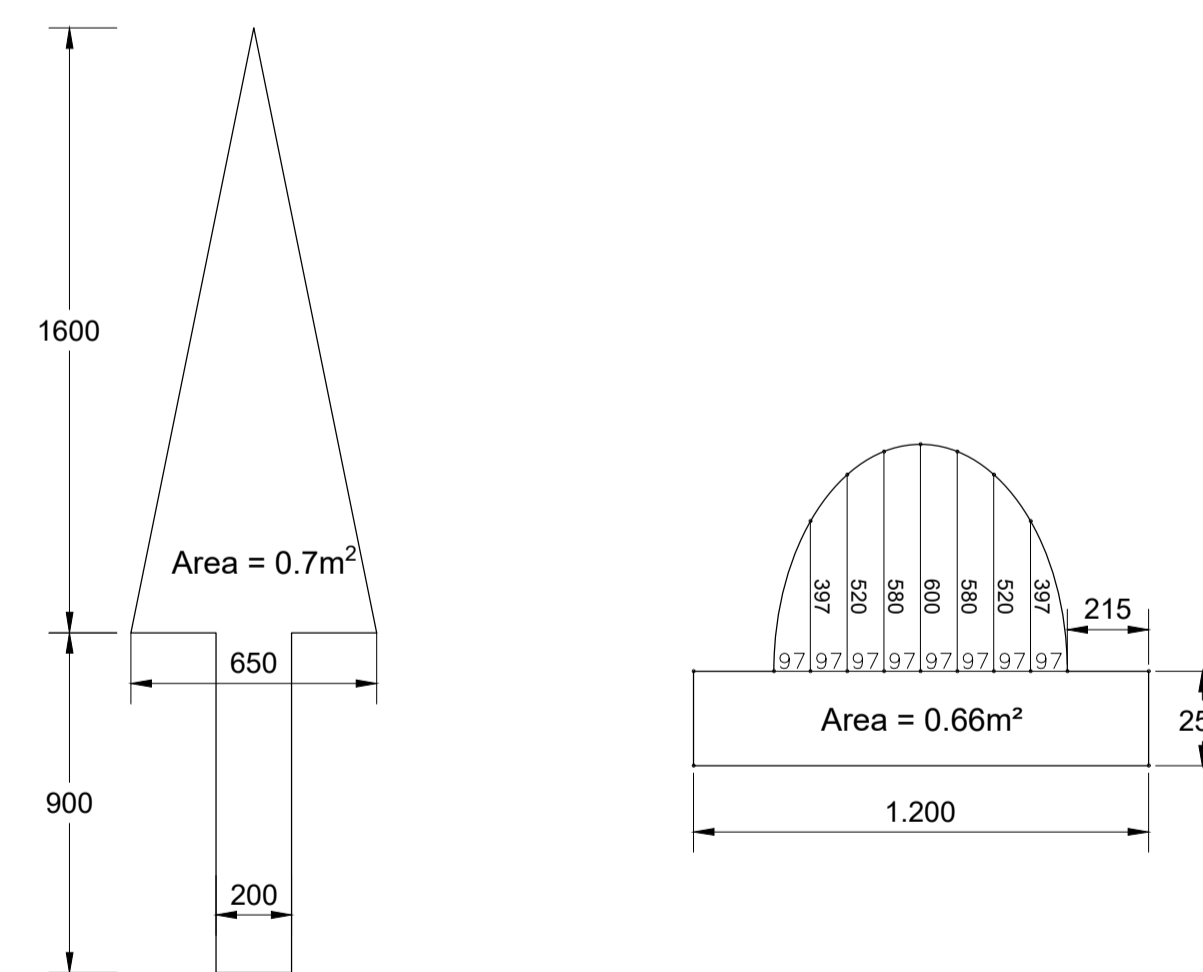

DETAIL OF SPEED HUMP ROAD MARKING
SCALE 1: 20

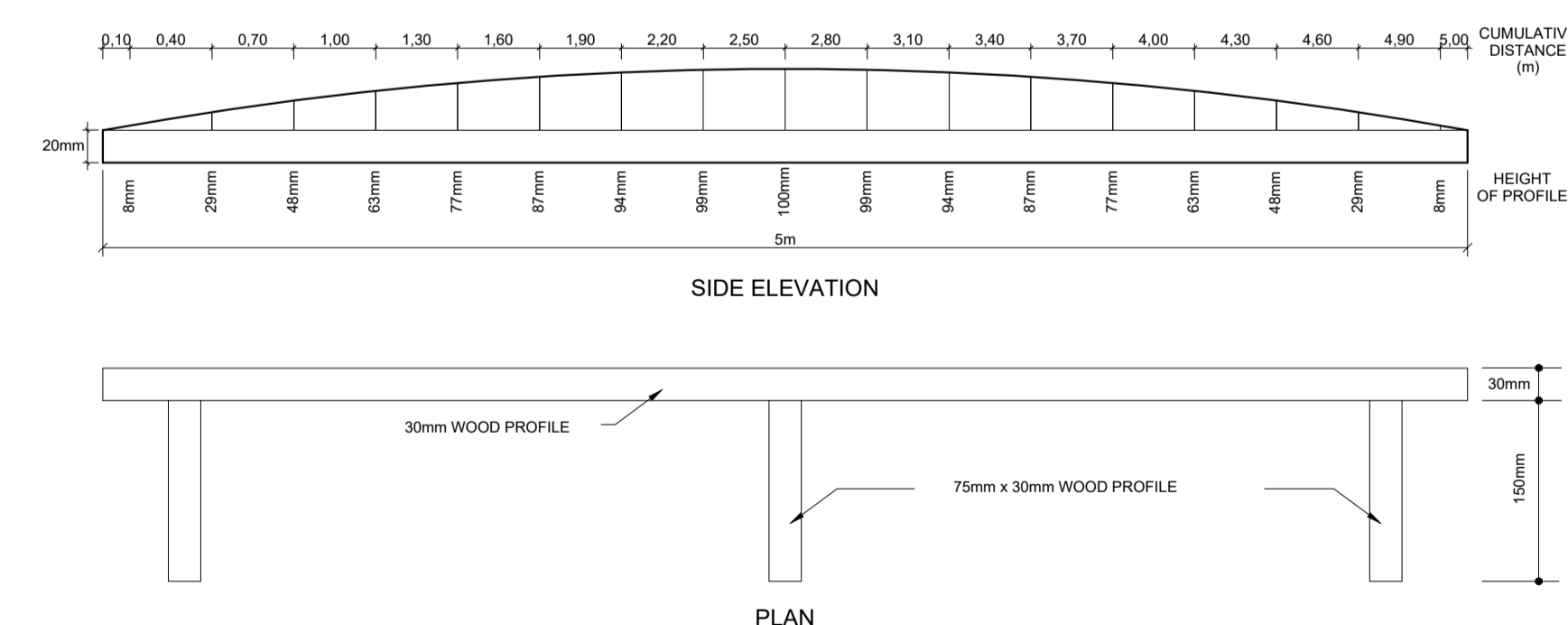

TEMPLATE DETAIL FOR CONSTRUCTION OF SPEED HUMP
SCALE 1: 20

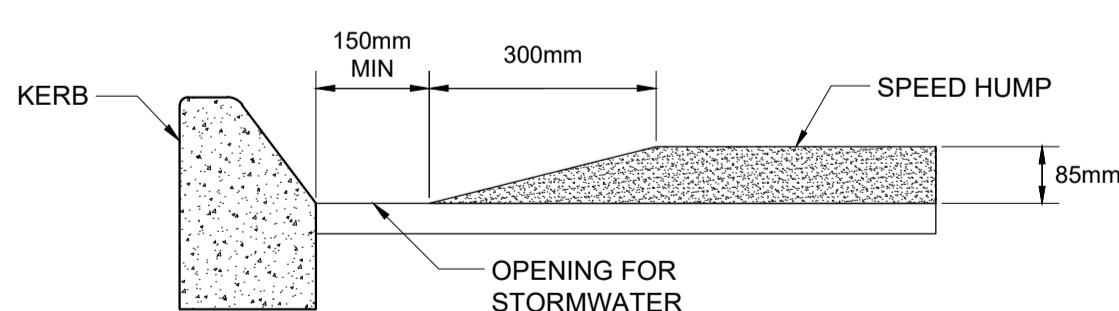

**SECTION B-B:
CONSTRUCTION DETAIL OF SPEED HUMP**

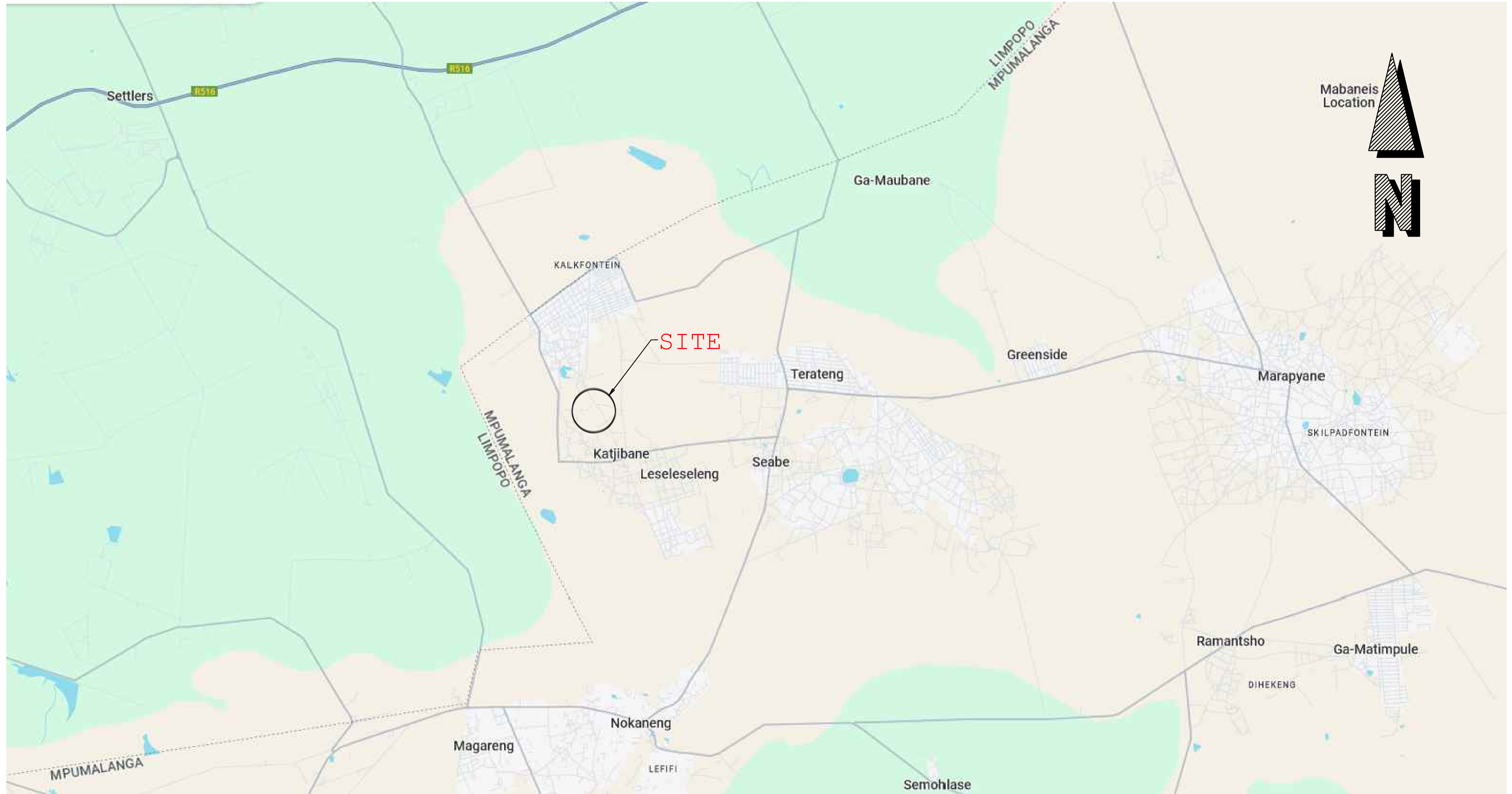

MORULA CONSULTING ENGINEERS



P.o.Box 2740
 POLOKWANE
 0007
 Tel: (015)291-1161
 Fax: (086) 558-6446



A2601/3 Bongimfundo Street
 Siyabuswa
 Tel: (013) 973 1101/0821
 Fax: (013) 973 2463/0973
 Email: info@moroka.gov.za

NO	AMENDMENTS	BY	APPROVED	DATE
01	AS BUILT RECORD ISSUED FOR APPROVAL	HT	HT	02/2025 06/2025

APPROVED ON BEHALF OF THE CONSULTING ENGINEER	REFERENCE
ENGINEER : _____ REG. No : _____ DATE : _____ SIGNATURE : _____	

DESIGNED	PROJECT ENGINEER

Project No: JSM / R02 / 25-26W27	
KATJIBANE BUS AND TAXI ROUTE (PHASE 4)	
LOCALITY PLAN	
CONTRACT DATE: 05-2025	DRAWING REVISION: ML/JS3/LAY-01

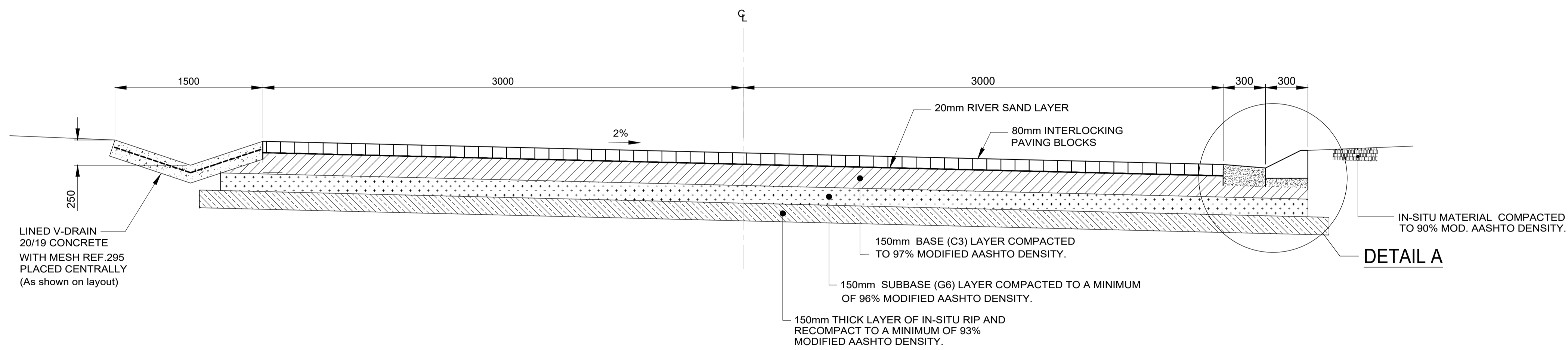

TYPICAL CROSS-SECTION & PAVEMENT DESIGN DETAILS

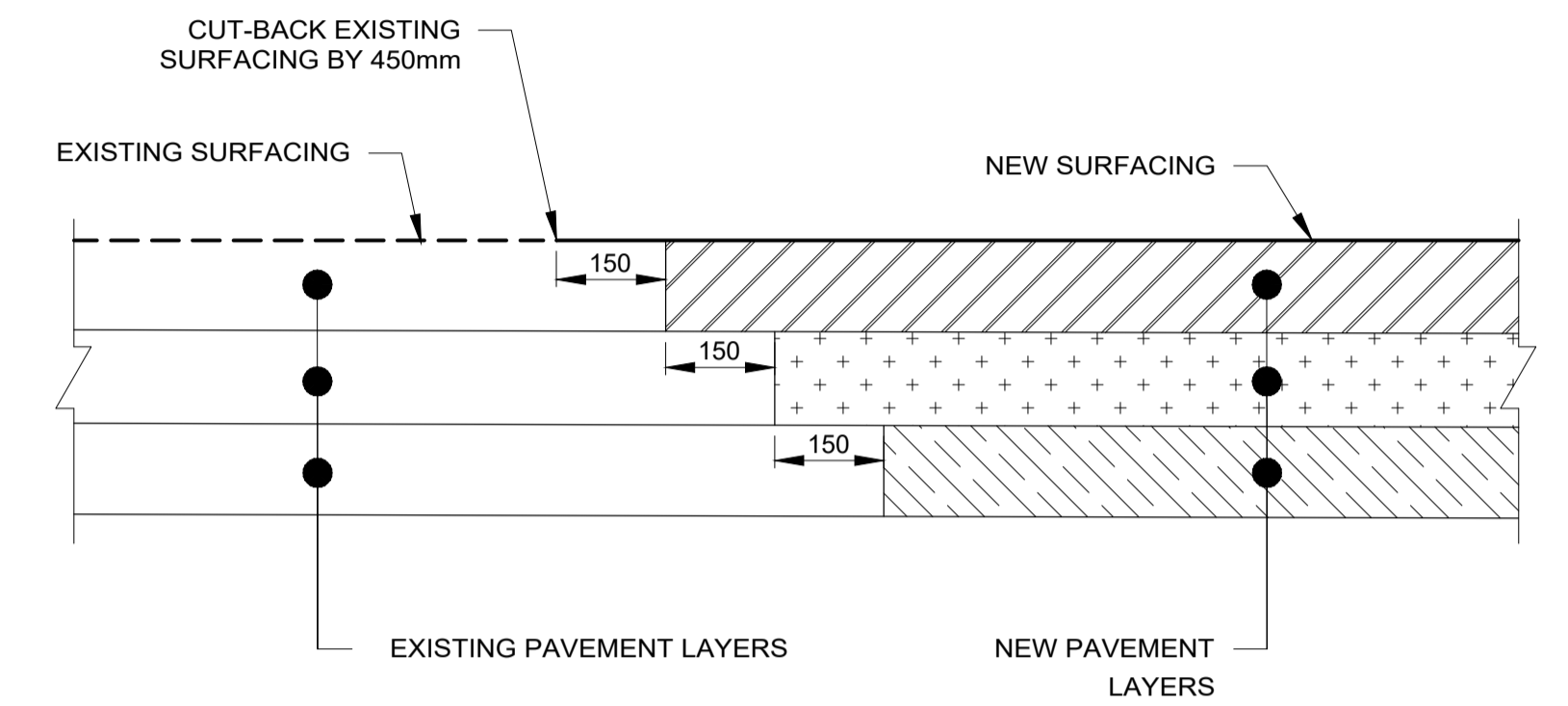

NEW CONSTRUCTION TO EXISTING PAVEMENT STRUCTURE JOINT DETAIL

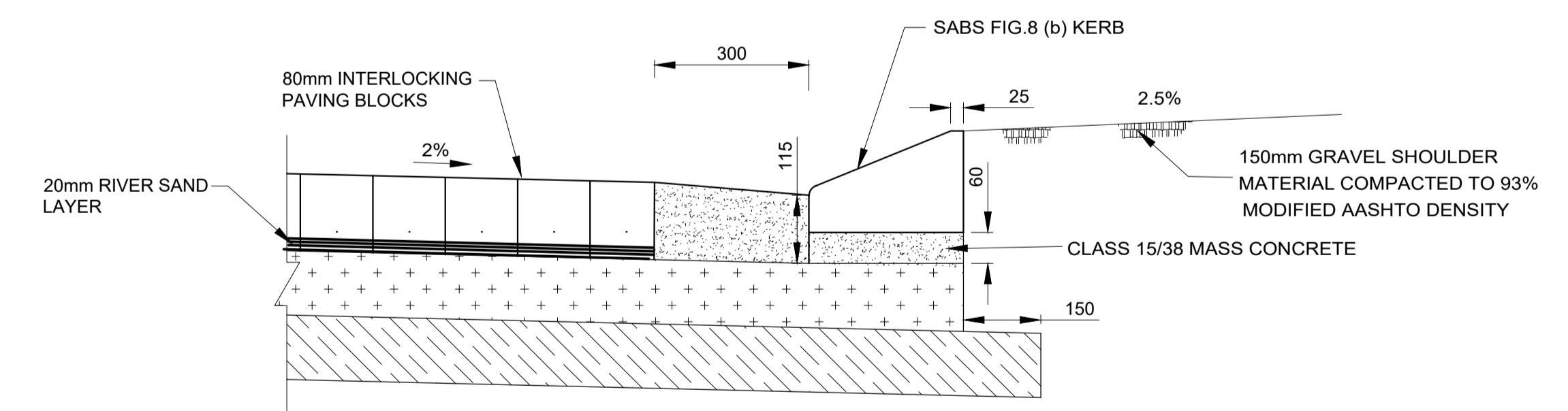

DETAIL A

NO	AMENDMENTS	BY	APPROVED	DATE
02	AS BUILT RECORD	ALT	ALT	02/02/25
00	ISSUED FOR APPROVAL			05/02/25

APPROVED ON BEHALF OF THE CONSULTING ENGINEER	REFERENCE
ENGINEER: _____	
REG. No: _____	
DATE: _____	
SIGNATURE: _____	

DESIGNED
DRAWN
REVIEWED
PROJECT ENGINEER

Project No: JSM / R02 / 25-26W27	
KATJIBANE BUS AND TAXI ROUTE (PHASE 4)	
TYPICAL CROSS SECTIONS AND PAVEMENT DESIGN	
CONTRACT: _____	DRAWING
DATE: 05-2025	ML/JS3/STD-01
	REVISION
	0

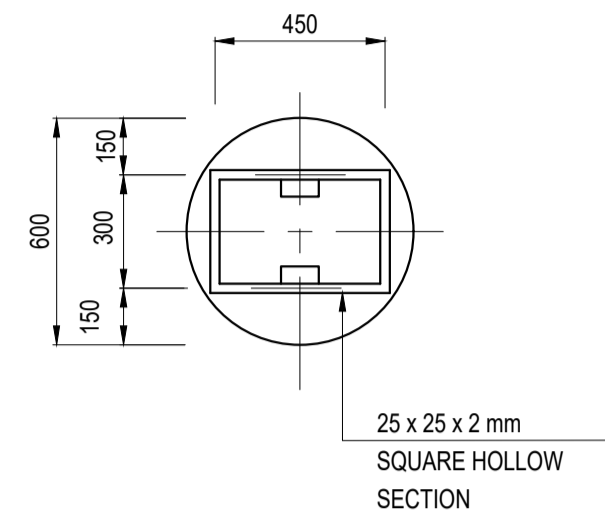

SINGLE SUPPORT

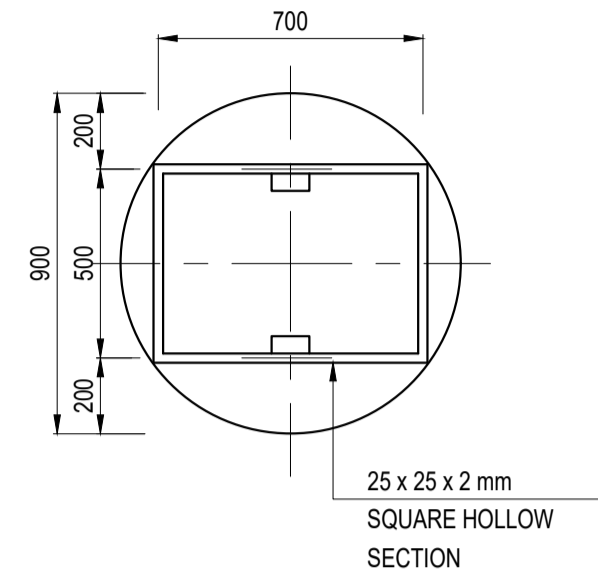

SINGLE SUPPORT
REINFORCEMENT FOR CIRCULAR ROAD SIGNS

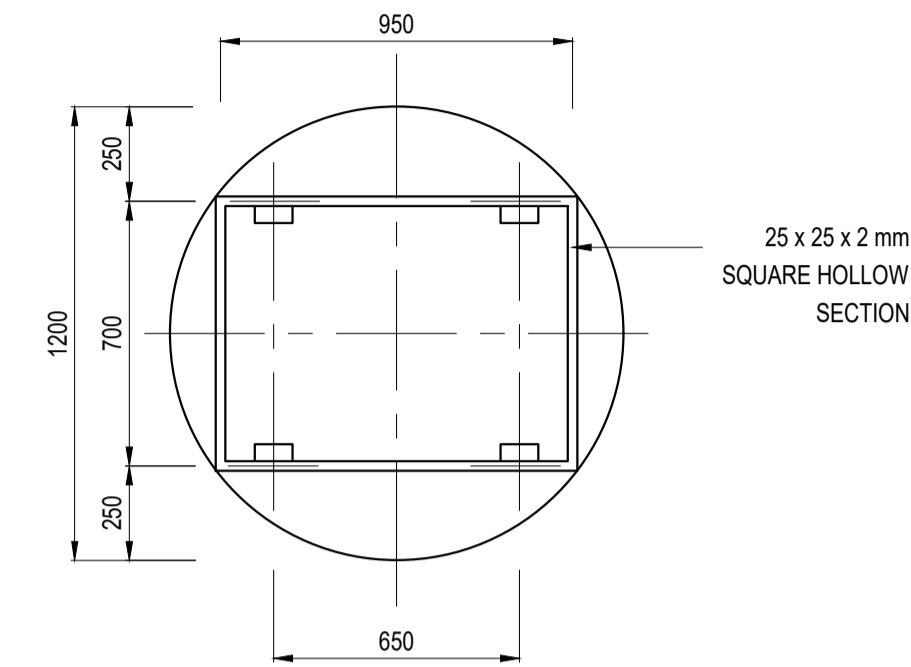

DOUBLE SUPPORT

MINIMUM REGULATORY SIGN SIZES			
	OPERATING SPEED (km/h)		
	100 - 120	70 - 90	60
CIRCULAR SIGN DIAMETER (mm)	1200	900	600
RECTANGULAR SIGN WxH (mm)	1200 x 900	900 x 675	600 x 450
TRIANGULAR SIGN SIDE LENGTH (mm)	1500	1200	900

SCALE 1 : 20

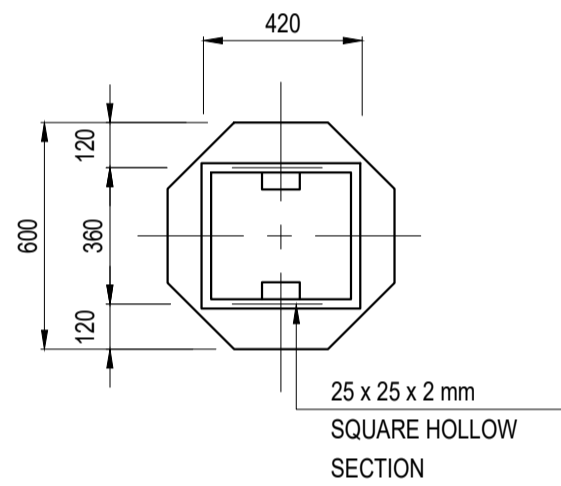

SINGLE SUPPORT

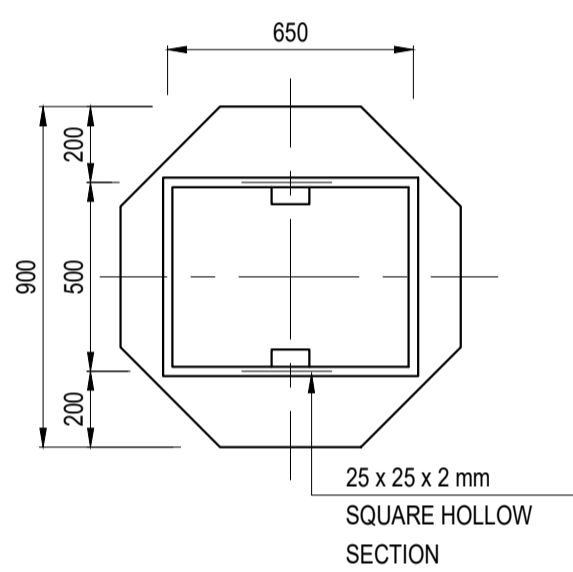

SINGLE SUPPORT
REINFORCEMENT FOR STOP SIGNS

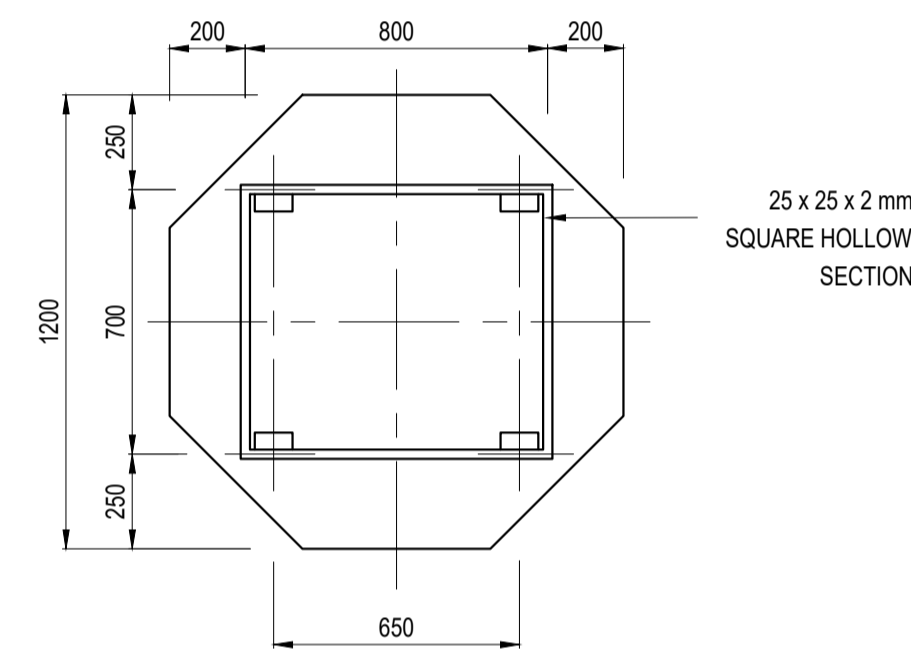

DOUBLE SUPPORT

ADVANCE WARNING SIGN LOCATION AND SIZE		
OPERATING SPEED (km/h)	LOCATION (DISTANCE FROM HAZARD) (m)	SIZE (mm)
120	330	1500
100	240	1500
80	160	1200
60	120	900

SCALE 1 : 20

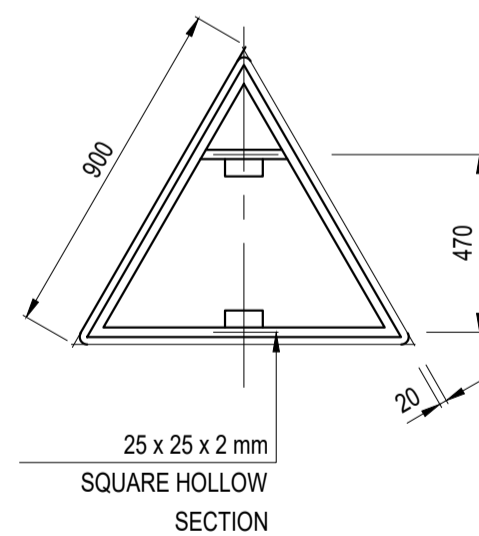

SINGLE SUPPORT

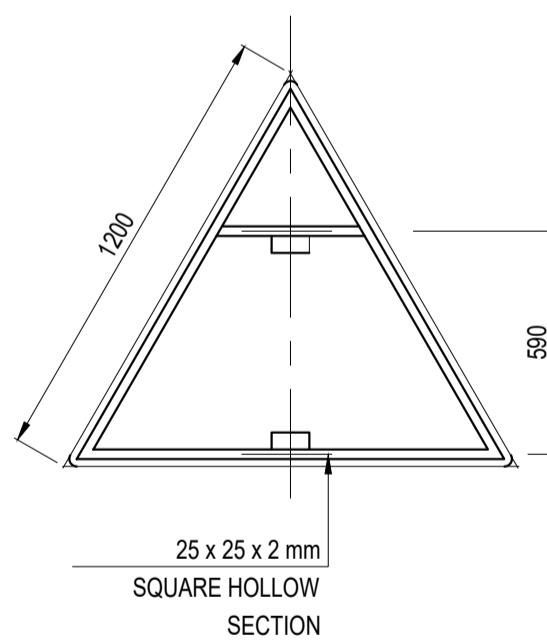

SINGLE SUPPORT

NOTE:
MINIMUM SIZE FOR
ERECTION BRACKETS
ON R/W SIGNS :
L 45 x 45 x 6
LENGTH : 100mm

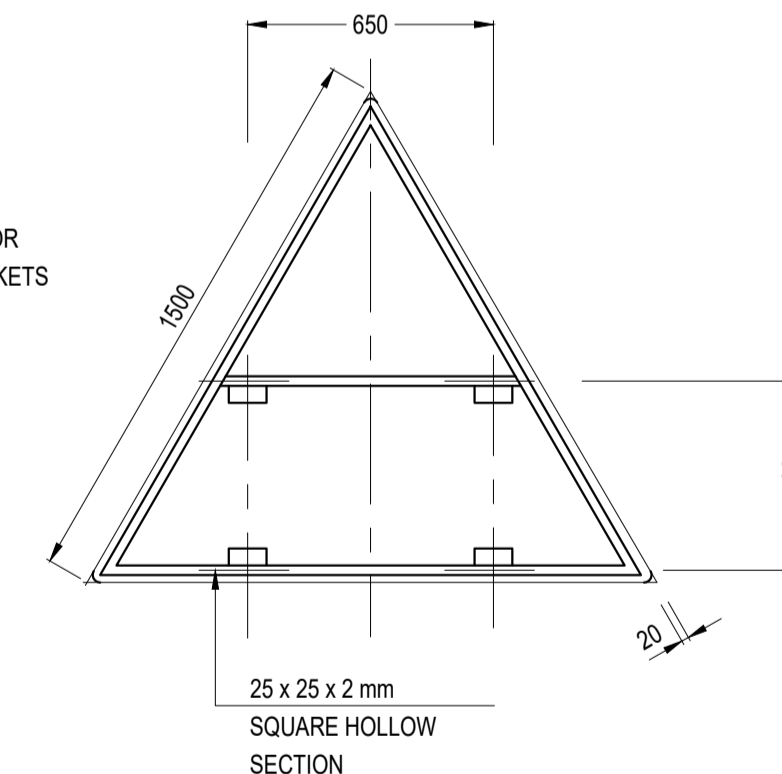

DOUBLE SUPPORT

REINFORCEMENT FOR TRIANGULAR ROAD SIGNS
SCALE 1 : 20

NOTES :

THE ROAD SIGN FACES SHALL BE MANUFACTURED AND ERECTED IN ACCORDANCE WITH THE FOLLOWING REQUIREMENTS :

- DETAILS ON THIS DRAWING ARE APPLICABLE TO ROAD SIGNS SMALLER THAN 1.5m² REQUIRING DOUBLE / SINGLE SUPPORTS.
- STRUCTURAL STEEL SECTIONS SHALL BE MILD STEEL CONFORMING TO THE REQUIREMENTS OF SANS 1431, GRADE 300W. RECTANGULAR HOLLOW SECTION AND SPECIAL CHANNEL PROFILES MAY BE COLD FORMED OF COMMERCIAL QUALITY MILD STEEL. ALL SECTIONS SHALL BE HOT-DIP GALVANISED IN ACCORDANCE WITH THE REQUIREMENTS OF SANS 121 : 2000 (ISO 1461 : 1999).

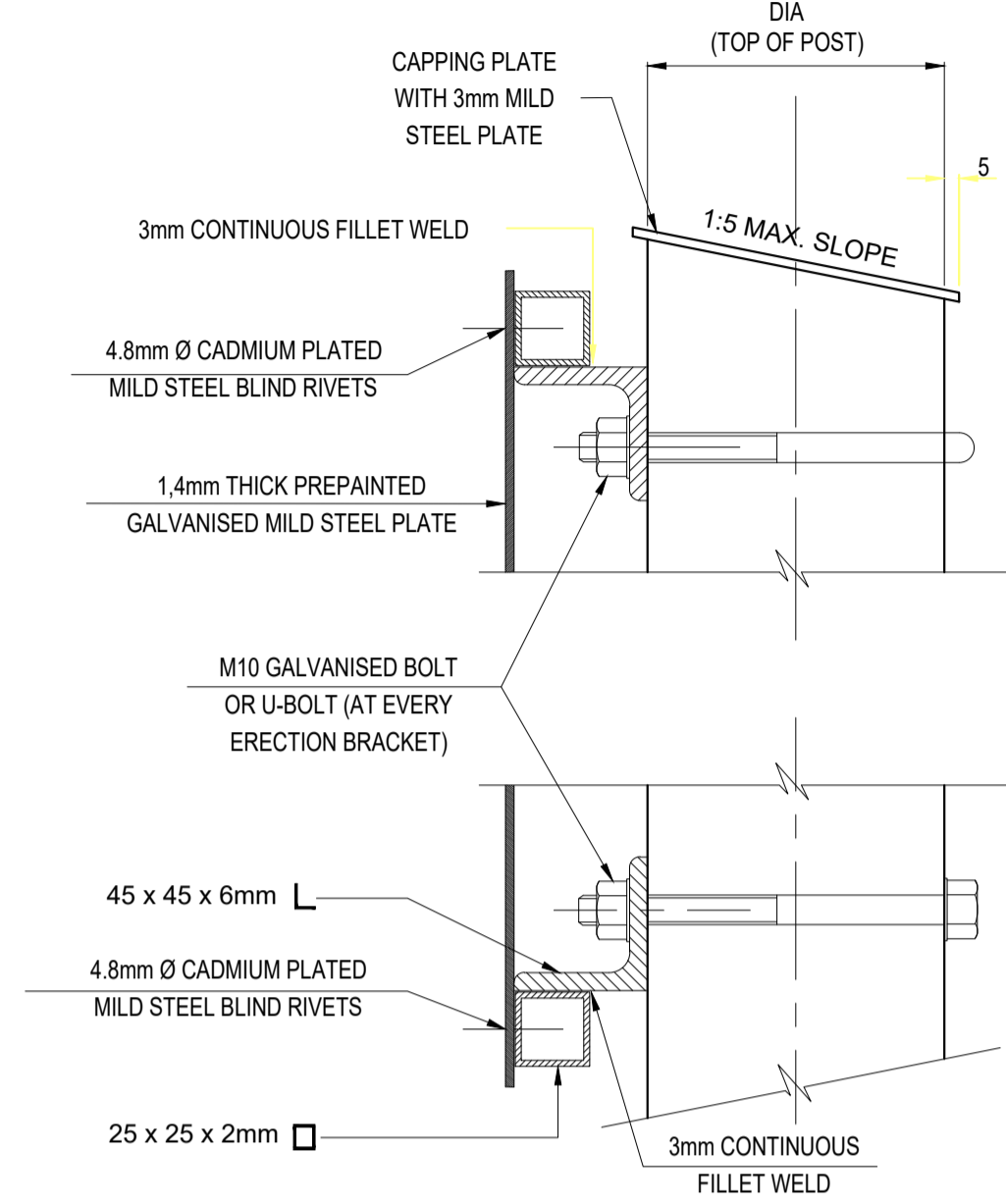

SIDE ELEVATION

SCALE 1 : 2,5

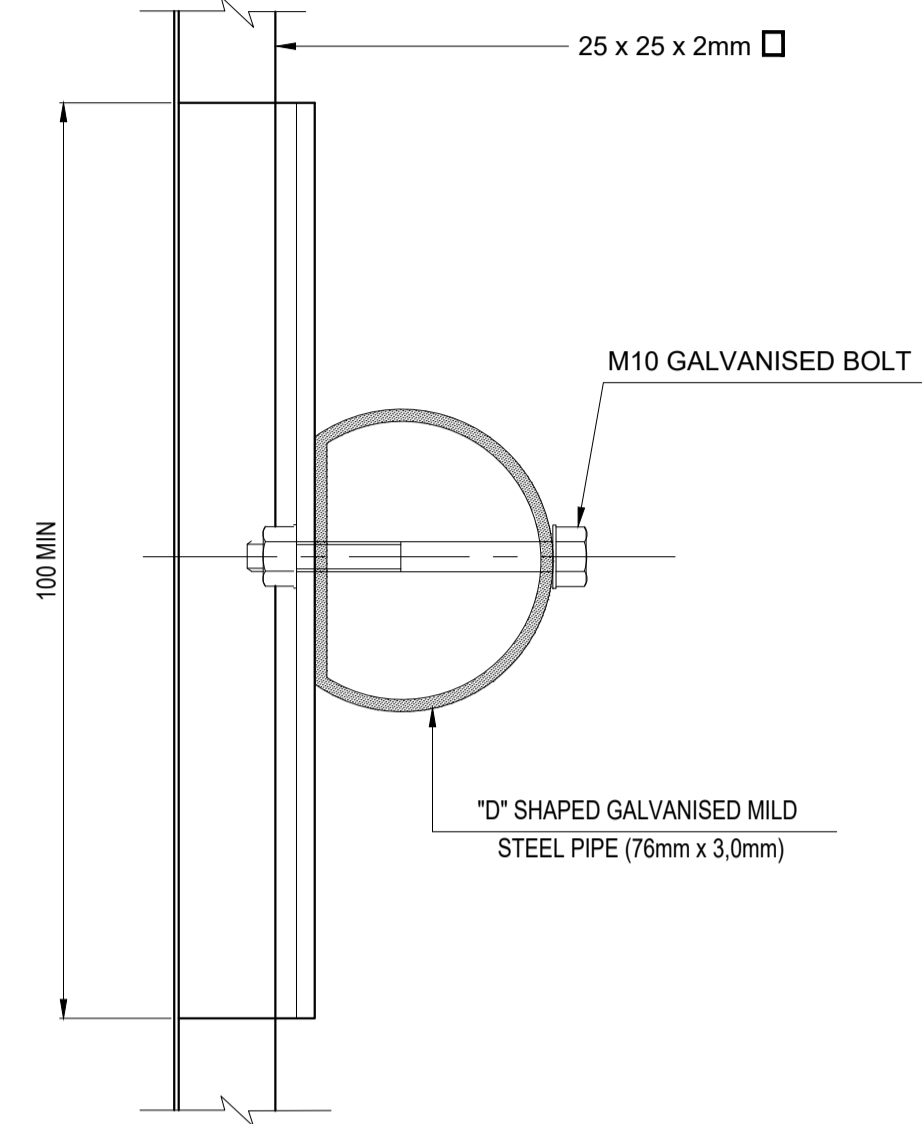

SIDE ELEVATION

SCALE 1 : 2

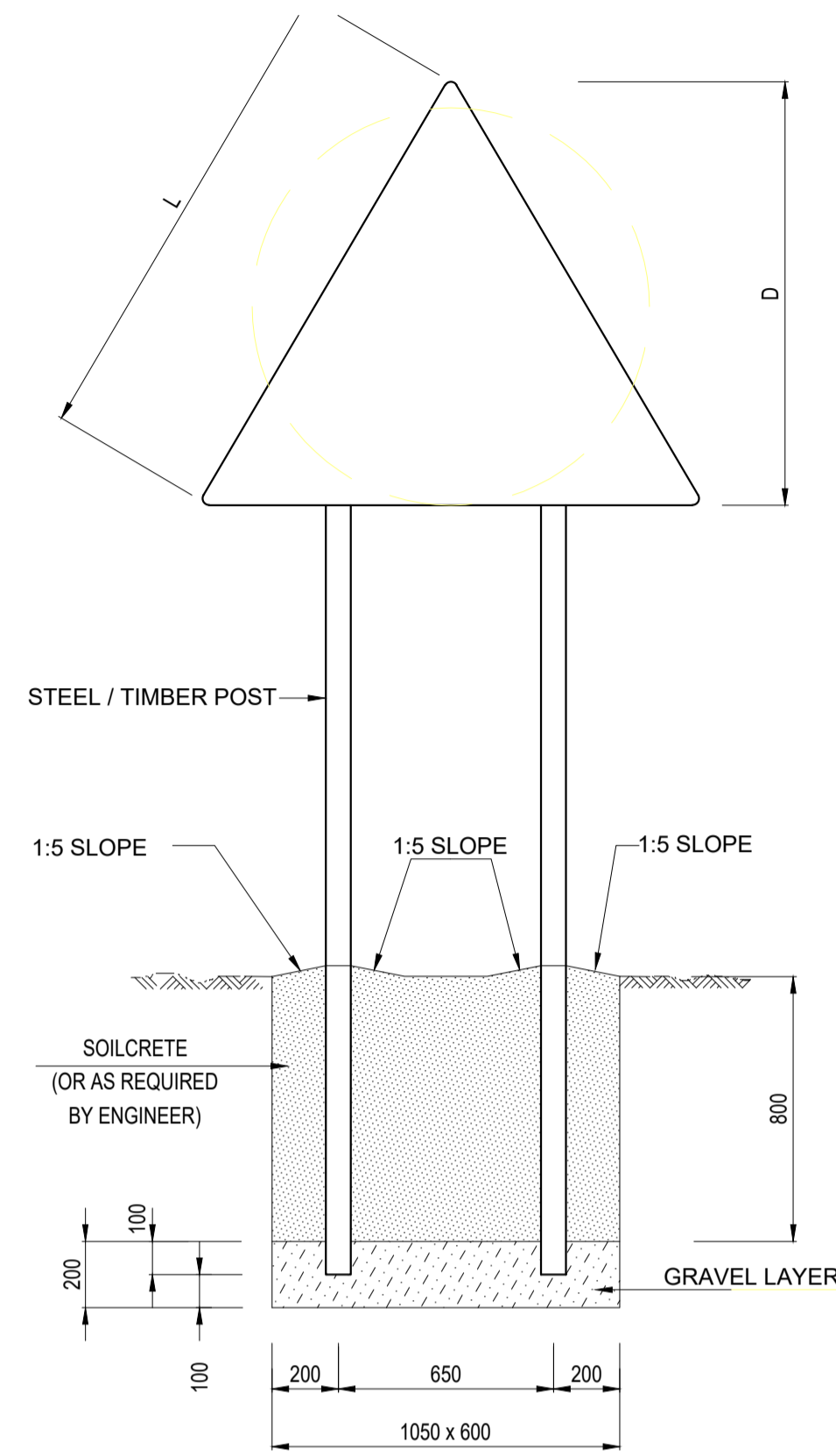

FOUNDATION DETAIL
L = 1500 AND D = 1200

SCALE 1:20

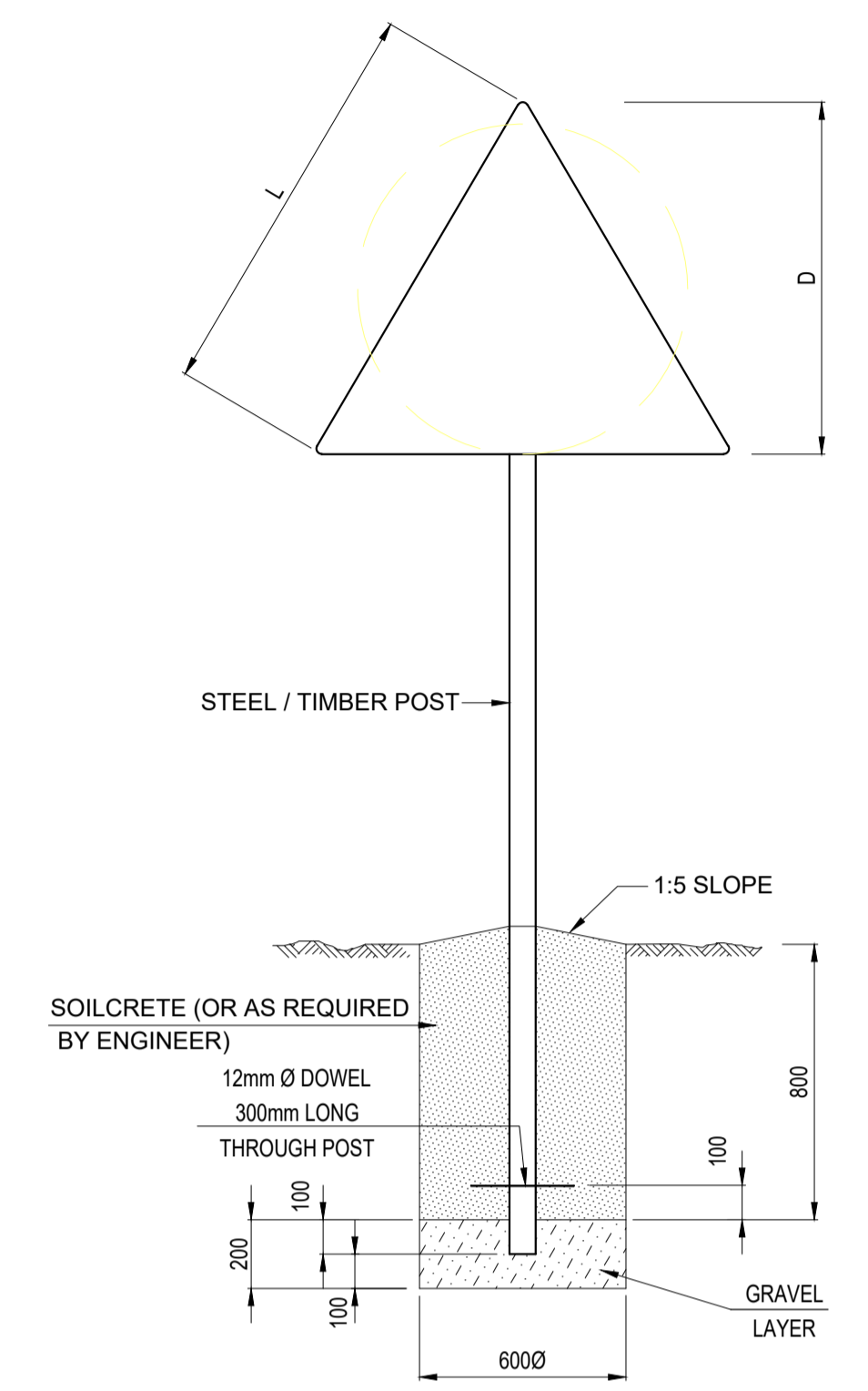

FOUNDATION DETAIL
L < 1200 AND D < 900

SCALE 1:20

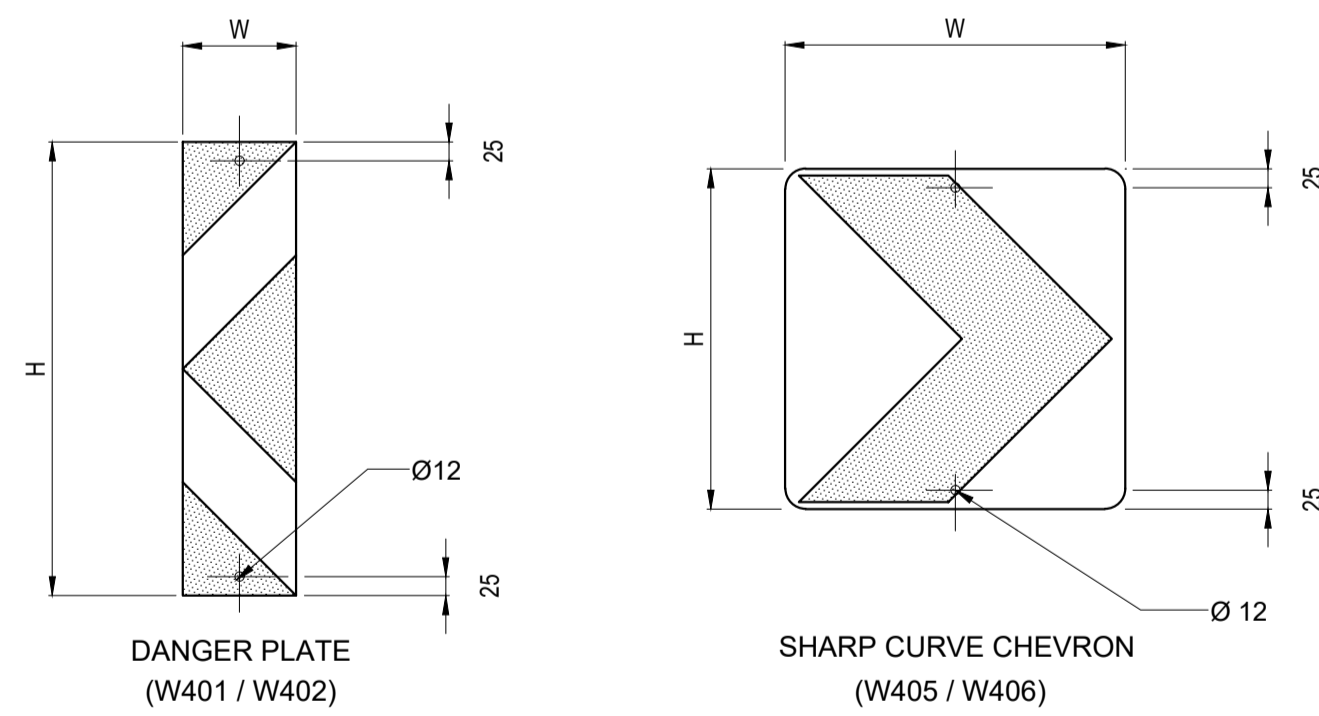

**MOUNTING HOLES FOR HAZARD MARKER
SIGNS WITHOUT FRAMEWORK**

HAZARD MARKER SIGNS		
	DANGER PLATE SIGN	SHARP CURVE CHEVRON
	W401-RIGHT W402-LEFT	W405-RIGHT W406-LEFT
OPERATING SPEED (km/h)	SIZE H x W (mm)	SIZE H x W (mm)
120	800 x 200	600 x 600
100	800 x 200	600 x 600
80	600 x 150	450 x 450
60	600 x 150	450 x 450

NOTES :

THE ROAD SIGN FACES SHALL BE MANUFACTURED AND ERECTED IN ACCORDANCE WITH THE FOLLOWING REQUIREMENTS :

- STRUCTURAL STEEL SECTIONS SHALL BE MILD STEEL CONFORMING TO THE REQUIREMENTS OF SANS 1431, GRADE 300W. RECTANGULAR HOLLOW SECTION AND SPECIAL CHANNEL PROFILES MAY BE COLD FORMED OF COMMERCIAL QUALITY MILD STEEL. ALL SECTIONS SHALL BE HOT-DIP GALVANISED IN ACCORDANCE WITH THE REQUIREMENTS OF SANS 121 : 2000 (ISO 1461 : 1999).
- TIMBER POLE SUPPORTS SHALL COMPLY WITH THE REQUIREMENTS SHOWN ON DRAWING TD-R-RS-001 & TD-R-RS-002
- BOLTS, WASHERS AND NUTS SHALL COMPLY WITH THE REQUIREMENTS OF SANS 1700-S-1 AND SHALL BE GALVANISED IN ACCORDANCE WITH THE REQUIREMENTS OF SANS 121 : 2000 (ISO 1461 : 1999).
- BLIND RIVETS SHALL BE 4.8mm DIA CADMIUM PLATED MILD STEEL.