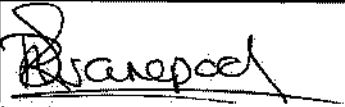
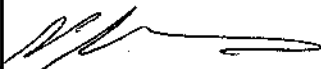
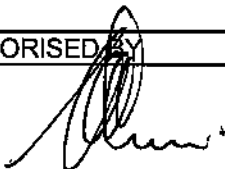

	Work Instruction	
---	-------------------------	--

Title: Work Instruction for Process (P&ID, PFD, PPF and SPFD), Hydraulic and Pneumatic Drawings	Unique Identifier: 36-945
	Old Doc No: GGW1533
	Document Type: GWN
	Revision: 0
	Effective date: April 2008
	Total pages: 117
	Revision date: March 2010
	Classification: Controlled Disclosure

COMPILED BY	FUNCTIONAL RESP.	AUTHORISED BY
 HF Swanepoel Leader of development team.	 P Khumalo Generation Technology Manager (Acting)	 T Moss General Manager (Generation Technology & Assurance Portfolio) (Acting)

Copyright © 2008 Generation Division, Eskom Holdings Limited

When downloaded from the Generation database, this document is uncontrolled and the responsibility rests with the user to ensure it is in line with the authorised version on the database

Work Instruction for Process (P&ID, PFD, PPF and SPFD), Hydraulic and Pneumatic Drawings	Unique Identifier:	36-945
	Revision:	0
Classification: Controlled Disclosure	Page:	2 of 117

CONTENTS	PAGE
SECTION A - GENERAL REQUIREMENTS	3
1. Scope	3
2. Purpose	3
3. Applicability	3
4. Superseded Standards	3
5. Reference Standards	3
6. Codification	4
7. Abbreviations	4
8. Definitions	5
9. CAD Software Requirements	6
10. Documentation	7
11. Classification of Drawings	7
12. Drawing Work Flow	8
13. Requesting of Drawings	8
14. Issuing of Drawings by Eskom	8
15. Issuing of New Drawing Numbers	8
16. Updating and Creating of Drawings	8
17. Drawing Checking Procedure	8
18. Non-Conformance Reporting (NCR)	8
19. Issuing of Drawings to Eskom	8
20. Electronic Format of Drawings Issued to Eskom	8
21. Paper Format of Drawings Issued to Eskom	8
22. Registration of Drawings	8
23. Revision Control	9
24. Contractor Information Back-Up	9
SECTION B - PFD's AND P&ID's IN ACCORDANCE WITH AKZ STANDARD	9
1. Software and Software Configuration	9
2. Predefined Settings	9
3. Standard Title Block	9
4. Starting a New PFD or P&ID Drawing Using Vision	10
5. Filling In The Title Block	10
6. Using the Toolboxes	11
7. Checking of PFD's and P&ID's	47
8. Create Project Database (PDB)	51
9. Database Verification of PFD's and P&ID's	51
SECTION C - PFD's AND P&ID's IN ACCORDANCE WITH KKS STANDARD	52
SECTION D - CUSTOMISED CAD FILES	54
1. Installation of Customised CAD Files for All Drawings	54
2. Installation of Customised CAD Files for P&ID's and PFD's	54
SECTION E - HYDRAULIC AND PNEUMATIC CIRCUIT DIAGRAMS	56
1. Installation of Customised CAD Files for All Drawings	56
2. Installation of Customised CAD Files for Hydraulic and Pneumatic Circuit Diagrams	56
3. General Requirements for Draughting Hydraulic and Pneumatic Circuit Diagrams	56
SECTION F - ANNEXURES	56
Revisions Information	117

Work Instruction for Process (P&ID, PFD, PPF and SPFD), Hydraulic and Pneumatic Drawings	Unique Identifier:	36-945
	Revision:	0
Classification: Controlled Disclosure	Page:	3 of 117

SECTION A - GENERAL REQUIREMENTS

1. SCOPE

The document specifies the procedures and standards that must be adhered to while compiling and distributing the following engineering drawings for the Generation Division:

- Functional Process Flow Diagrams (FPFD)
- Piping and Instrumentation Diagrams (P&ID)
- Primary Process Flow Diagrams (PPFD)
- Secondary Process Flow Diagrams (SPFD)
- Hydraulic and Pneumatic Circuit Diagrams

2. PURPOSE

The purpose of the document is to define the work instructions and requirements that must be followed by the internal Eskom drawing office(s) and Contractor's drawing office staff for producing these types of drawings for the Generation Division. The document specifically defines the procedures and standards for an electronic drawing office utilising Bentley software.

3. APPLICABILITY

This document is applicable to both Eskom Drawing Office(s) and Contractors rendering a draughting service for Eskom Generation Division.

4. SUPERSEDED STANDARDS

The following Eskom Generation Standards are superseded by this document.

Document No	Revision	Title
167A/143	00	Drawing Office Practice
GGG 0450	0	Guideline to Acceptance of Contract Drawings
GGG 0182	1	Process Flow Diagrams and Piping Instrumentation Diagrams
GGG 0315	0	Standard Drawing Practice
GGG 0441	0	Drawing Records System
GSE/94/Y004	1	Standard Drawing Practice

5. REFERENCE STANDARDS

This document is to be read in conjunction with the following standards:

Document No	Rev	Title
36-1	1	Standard for Management System Documents, Correspondence And Records
GGG 0991	01	Standard for Management System Documents, Correspondence and Records
LIM 103	11	AKZ Identification System
GGG 1016		KKS Identification System
OPS 0014	1	KKS Key Parts
GGG 0442	1	Abbreviation Standard for Chemistry related items for power stations
GGG 0443	2	Abbreviation Standard for Labelling of plant at power stations
GGG 0445	1	Drawing Number System
ISO 3098 Part I: 2000	-	Technical Drawings - Lettering
ISO 5455: 1995	-	Technical Drawings - Scales
ANSI Z32.11		Graphical Symbols for Process Flow Diagrams
ANSI Z32.2.3		Graphical Symbols for Pipe Fittings, Valves & Piping

Work Instruction for Process (P&ID, PFD, PPF and SPFD), Hydraulic and Pneumatic Drawings	Unique Identifier:	36-945
	Revision:	0
Classification: Controlled Disclosure	Page:	4 of 117

6. CODIFICATION

6.1 The plant codification must be in accordance with LIM 103 - AKZ Identification System for the following site:

- 6.1.1 Duvha Power Station
- 6.1.2 Kriel Power Station
- 6.1.3 Lethabo Power Station
- 6.1.4 Matla Power Station

6.2 The plant codification must be in accordance with GGG 1016 - KKS Identification System and OPS 0014 – KKS Key Parts Identification System for the following sites:

- 6.2.1 Acacia Power Station
- 6.2.2 Ankerlig Power Station
- 6.2.3 Arnot Power Station
- 6.2.4 Camden Power Station
- 6.2.5 Drakensberg Pumped Storage Scheme
- 6.2.6 Gariiep Power Station
- 6.2.7 Gourikwa Power Station
- 6.2.8 Grootvlei Power Station
- 6.2.9 Hendrina Power Station
- 6.2.10 Ingula Power Station
- 6.2.11 Kendal Power Station
- 6.2.12 Komati Power Station
- 6.2.13 Majuba Power Station
- 6.2.14 Matimba Power Station
- 6.2.15 Medupi Power Station
- 6.2.16 Palmiet Pump Storage Scheme
- 6.2.17 Port Rex Power Station
- 6.2.18 Tutuka Power Station
- 6.2.19 Vanderkloof Power Station

6.3 The required codification standard for Nuclear Plant is obtainable from the Drawing & Design Office at Koeberg Power Station. The plant codification must be in accordance with nuclear plant requirements for the following sites:

- 6.3.1 Koeberg Power Station
- 6.3.2 Pebble Bed Modular Reactor (PBMR)
- 6.3.3 Future Nuclear Power Stations

6.4 The numbering of drawings shall be done in accordance with GGS 0445 (Generation Drawing Number System Standard). Only Section 4.1.1, 4.1.3 and Annexures A, C, G, H, L, M and R of GGS 0445 shall apply for use with this drawing standard.

7. ABBREVIATIONS

- 7.1 BCP - Business Continuity Plan
- 7.2 CAD - Computer Aided Draughting
- 7.3 DGN - Bentley MicroStation Drawing File Extension
- 7.4 DRP - Disaster Recovery Plan
- 7.5 DWG/DXF - AutoCAD Drawing File Extensions
- 7.6 EDMS - Electronic Document Management System
- 7.7 HVAC - Heating Ventilation Air Conditioning

Work Instruction for Process (P&ID, PFD, PPF and SPFD), Hydraulic and Pneumatic Drawings	Unique Identifier:	36-945
	Revision:	0
Classification: Controlled Disclosure	Page:	5 of 117

7.8	IBI	-	Integrated Business Improvement Philosophy/Methodology
7.9	MWP	-	Megawatt Park
7.10	MTBF	-	Mean Time Between Failures
7.11	MTTR	-	Mean Time To Repair
7.12	NCR	-	Non Conformance Report
7.13	NDT	-	Non-Destructive Testing
7.14	OEM	-	Original Equipment Manufacturer
7.15	OHSAct	-	Occupational Health and Safety Act of 1993
7.16	PDF	-	Portable Document Format
7.17	PDB	-	Project Data Base
7.18	P&ID	-	Process & Instrumentation Diagram/Piping & Instrumentation Diagram
7.19	PFD	-	Process Flow Diagram
7.20	PPE	-	Personnel Protective Equipment
7.21	Pr Eng	-	Professional Engineer registered in terms of the Engineering Profession Act, 2000
7.22	RCM	-	Reliability Centred Maintenance
7.23	RFT	-	Request for Tender
7.24	SoW	-	Scope of Work
7.25	TIFF	-	Tagged Image File Format

8. DEFINITIONS

- 8.1 As Built Drawing:** Drawing which is verified as an exact representation of a plant or a section of a plant that has been completely built.
- 8.2 Check Print:** Drawing which is printed and utilised for verification of a drawing during the drawing checking procedure.
- 8.3 Contractor:** A party appointed by Eskom to render services.
- 8.4 Data Mining:** For the purposes of this standard *Data Mining* shall be the extraction of Text Tagged data from CAD drawings.
- 8.5 Controlled Copy:** A copy of a document held by a documentation/satellite centre or by a designated individual that has the guarantee that it is the latest and current valid revision. This copy shall be clearly stamped in red "CONTROLLED COPY". All controlled documents that are printed will be considered valid for a maximum period of 24 hours. Users shall always reference back to the EDMS for the latest version of a document.
- 8.6 Deviation Process:** This process is the initiator of engineering activities to permanently address plant deficiencies or incidents.
- 8.7 Draughtsperson:** A person responsible for the creation and updating of drawings, in accordance with this standard.

Work Instruction for Process (P&ID, PFD, PPF and SPFD), Hydraulic and Pneumatic Drawings	Unique Identifier:	36-945
	Revision:	0
Classification: Controlled Disclosure	Page:	6 of 117

- 8.8 Functional Process Flow Diagram (FPFD):** Diagram showing all or a recognisable portion of the process, complete with a material and/or heat balance sheet. It contains details of operating parameters such as flow rate, temperature and pressure.
- 8.9 Piping and Instrumentation Diagram (P&ID):** Diagram which shows limited details of the mechanical and electrical components, pipework and ducting, and identifies all the measuring points and control elements that are necessary to measure and control that process.
- 8.10 Plant System:** A collection of plant components connected in such a way that each will perform a unique process, thereby achieving specified performance parameters.
- 8.11 Preliminary:** When a drawing is authorised but has not been implemented or has not reached 'As-Built' status.
- 8.12 Primary Process Flow Diagram (PPFD):** Diagram which indicates the major process as well as the process values through all or most of the main plant items of a given power station or system.
- 8.13 Project Configuration Files:** The customised setup files that must be utilised in conjunction with Bentley PlantSpace P&ID.
- 8.14 Secondary Process Flow Diagram (SPFD):** Secondary process flow diagram is similar to the primary process flow diagram (PPFD), except that it only deals with one particular system or subsystem of plant, and in more detail.
- 8.15 Text Tagging:** For the purposes of this standard Text Tagging shall be the process of adding electronic text tags into a CAD drawing for the purpose of data mining.

9. CAD SOFTWARE REQUIREMENTS

The minimum CAD software requirements are specified below, additional add-on Bentley software packages can be utilised.

9.1 MicroStation version 08.05.02.27

Used for General Arrangement, Sectional Views and Detail Drawings for the following:

- Architectural
- Civil
- Structural
- Mechanical
- Piping
- HVAC
- Electrical
- Hydraulic and Pneumatic Circuit Diagrams
- Text Tagging of existing drawings for data mining

9.2 PlantSpace P&ID version 08.05.01.20 and PlantSpace Schematic version 08.05.01.22

Used by sites draughting intelligent P&ID's, for the Following Process Diagrams

- Process Flow Diagrams (P&ID, PFD, PPF, SPFD's)
- Piping and Instrumentation Diagrams

9.3 Knowledge Manager Version 08.05.0.10

- Used for Mining of Text Tagged Drawings

9.4 Data Manager Version 08.06.0.79

- Used for the Management of Equipment Data Sheets

Work Instruction for Process (P&ID, PFD, PPF and SPFD), Hydraulic and Pneumatic Drawings	Unique Identifier:	36-945
	Revision:	0
Classification: Controlled Disclosure	Page:	7 of 117

9.5 Vision version 08.06.0.79

Universal Viewing Interface used by sites using intelligent P&ID's and text-tagging. Used for:

- PlantSpace P&ID
- Knowledge Manager
- Data Manager

9.6 Bentley I/RAS B 2004 Edition Version 08.05.02.27

This shall be used as the Viewing and Editing Interface for sites making use of hybrid drawings, eg drawings consisting of a.tif layer and a .dgn layer.

10. DOCUMENTATION

The requirements for specific drawing documents are specified below:

10.1 Process Flow Diagrams (PPFD, SPFD and FPDF)

- Graphical layout of the plant presented in single-line format
- Only standard symbology defined in this Work Instruction may be used
- Clear process flow direction to be indicated by means of arrows
- Component names/descriptions to be displayed on the Diagrams
- Codification of plant equipment to the appropriate level (dependant on the system depicted)
- Indication of relevant elevations, if required

10.2 Piping and Instrumentation Diagrams (P&ID)

- Presentation in single-line arrangement of the piping and ducting as well as the mechanical, electrical and instrumentation components
- Basic details of pipe sizes (nominal bore) and duct sizes (flow area)
- Clear process flow direction indicated by means of arrows
- Only standard P&ID symbology defined in this Work Instruction may be used
- Addition of component names/descriptions
- Display of plant unique codes in accordance with the relevant plant codification system
- Indication and use of Off-Sheet Connectors, indicating all process line interfaces with other P&ID diagrams
- The descriptive title of the relevant process line, as well as the number of the process line
- The Reference Diagram to where the link is, shall be shown inside the off sheet connectors
- Codification tags, flags and markers as per configured software
- Incorporation of pipe specifications into line numbers (where required)

11. CLASSIFICATION OF DRAWINGS

Drawings shall be classified according to 36-943, Section A.11.

Work Instruction for Process (P&ID, PFD, PPF and SPFD), Hydraulic and Pneumatic Drawings	Unique Identifier:	36-945
	Revision:	0
Classification: Controlled Disclosure	Page:	8 of 117

12. DRAWING WORK FLOW

The issuing, updating and creating of drawings shall be in accordance with the Drawing Work Flow as per 36-943, Section A.12.

13. REQUESTING OF DRAWINGS

Requesting of Plant Process drawings as defined per section A.1 of this instruction shall be done in accordance with 36-943, Section A.13.

14. ISSUING OF DRAWINGS BY ESKOM

The management process of issuing, updating and creating of Plant Process Drawings shall be in accordance with 36-943, Section A.14.

15. ISSUING OF NEW DRAWING NUMBERS

The issuing of drawing numbers for Plant Process Drawings and Hydraulic and Pneumatic Circuit Diagrams shall be in accordance with 36-943, Section A.15.

16. UPDATING AND CREATING OF DRAWINGS

16.1 PFD's and P&ID's must be created and updated in accordance with "SECTION B" of this standard.

16.2 Where Process Drawings are drawn "non-Intelligently" in MicroStation, the required standard symbology indicated in Annexure "A" of this work instruction will still apply and should be adhered to.

17. DRAWING CHECKING PROCEDURE

An auditable drawing checking procedure shall be used for Plant Process Drawings, Hydraulic and Pneumatic Circuit Diagrams as per 36-943, Section A.17.

18. NON CONFORMANCE REPORTING (NCR)

Non-Conformance reporting on Plant Process Drawings and Hydraulic and Pneumatic Circuit Diagrams and its associated management process shall be in accordance with 36-943, Section A.18.

19. ISSUING OF DRAWINGS TO ESKOM

Issuing of Plant Process Drawings and Hydraulic and Pneumatic Circuit Diagrams shall be in accordance with 36-943, Section A.19.

20. ELECTRONIC FORMAT OF DRAWINGS ISSUED TO ESKOM

All drawings must be issued to Eskom in electronic MicroStation (.DGN) format. No drawings in TIFF, PDF or any other electronic format will be accepted. The drawings issued to Eskom may not be "Write Protected" or encrypted, as Eskom needs full access to the drawings in order to do configuration management on it.

21. PAPER FORMAT OF DRAWINGS ISSUED TO ESKOM

The issuing of Plant Process Drawings in paper format shall be in accordance with 36-943, Section A.21.

22. REGISTRATION OF DRAWINGS

The Registration of Plant Process Drawings and Hydraulic and Pneumatic Circuit Diagrams into the specified EDMS shall be in accordance with 36-943, Section A.22.

Work Instruction for Process (P&ID, PFD, PPF and SPFD), Hydraulic and Pneumatic Drawings	Unique Identifier:	36-945
	Revision:	0
Classification: Controlled Disclosure	Page:	9 of 117

23. REVISION CONTROL

Revision Control of Plant Process Drawings and Hydraulic and Pneumatic Circuit Diagrams shall be in accordance with 36-943, Section A.23.

24. CONTRACTOR INFORMATION BACKUP

24.1 The Contractor must ensure that all drawing data is backed up on a regular basis to minimise possible data and information loss. This should include any databases used in the creation of Plant Process Drawings, Hydraulic and Pneumatic Circuit Diagrams and plant configuration data integrity checking.

24.2 The maximum period between backups must not exceed 24 hours.

24.3 The backups must be carried out utilising an offsite rotating backup system.

SECTION B - PFD'S AND P&ID'S IN ACCORDANCE WITH AKZ STANDARD

1. SOFTWARE AND SOFTWARE CONFIGURATION

1.1 Standard configuration files and directories have been setup and must be copied into the directories as specified in Generation Standard Work Instruction 36-944 prior to creating or updating PFD's and P&ID's. This is available from Generation Information Management who manages this information asset.

1.2 All drawings must be updated and created utilising the software specified in Clause A.9.2.

1.3 The configuration specified in this standard must be adhered to, no deviations will be permitted.

1.4 All drawings must be updated and created utilising the standard software configuration files specified in 36-944.

2. PREDEFINED SETTINGS

2.1 Symbol Library

2.1.1 Standard symbols have been defined in the PlantSpace P&ID and are attached in Annexure "A" and cannot be changed by the user. The cell library based on this standard symbol list shall also be used where Process Drawings are drawn using Bentley MicroStation.

2.2 Layer and colours

2.2.1 Standard layers and colours have been defined in the PlantSpace P&ID setting manager and cannot be changed by the user.

2.3 Standard Text Format

2.3.1 Standard text formats have been predefined in PlantSpace P&ID for all PlantSpace P&ID tagged items.

2.3.2 No additional text must be placed in the drawing area that are not relevant to the definition of plant codes and equipment types.

3. STANDARD TITLE BLOCK

3.1 The standard Title Block includes predefined data fields with predefined text formats, layers and colours using ESCOMFT82.

3.2 The predefined text setting associated with each data field must not be changed.

Work Instruction for Process (P&ID, PFD, PPF and SPFD), Hydraulic and Pneumatic Drawings	Unique Identifier:	36-945
	Revision:	0
Classification: Controlled Disclosure	Page:	10 of 117

- 3.3 The applicable data must be filled in by the draughtsperson.
- 3.4 The data fields are switched off by default and can be switched on in the MicroStation View Attributes.
- 3.5 The standard Title Block includes a predefined section for Contractor's and the following information must be recorded in this section:
 - 3.5.1 Contactor logo if applicable
 - 3.5.2 Full Contactor name
 - 3.5.3 Contactor physical address
 - 3.5.4 Contactor telephone numbers
 - 3.5.5 Contactor project reference number
 - 3.5.6 Contactor internal revision details
- 3.6 Standard layers and colours have been defined for the Contractor's Title Block as "TitleBlockContractor".
- 3.7 No other section of the drawing is to be utilised by the Contractor to record Contractor information.

4. STARTING A NEW PFD OR P&ID DRAWING USING VISION

- 4.1.1 To create a new PFD or P&ID using Vision and PlantSpace P&ID the following steps must be followed:
 - Start Vision by selecting the Vision icon
 - Ensure that the EskomAKZ_pdb configuration is selected. (This can be seen in the top blue section of the Vision window)
 - Right click on "PlantSpace P&ID" in the "Document Tab" and select "New"
 - The "New Document" dialog box will open
 - Enter the drawing number of the new drawing in the "File Name" box
 - The "Name" and "Description" fields must not be filled in as they will be populated by the PlantSpace P&ID once the drawing is processed to the PDB
 - The location of the drawing must be selected as indicated below:

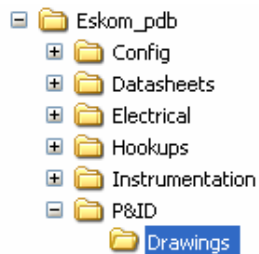

- Select PlantSpace P&ID followed by the "Create" button
- PlantSpace P&ID will open the new drawing with the required configuration files loaded

5. FILLING IN THE TITLE BLOCK

- 5.1 The following Title Block information must be filled in by selecting the Tag Component Tool and selecting the Eskom section of the Title Block:



- project_name - Lethabo Power Station
- unit number - Unit number

Work Instruction for Process (P&ID, PFD, PPF and SPFD), Hydraulic and Pneumatic Drawings	Unique Identifier:	36-945
	Revision:	0
	Page:	11 of 117
Classification: Controlled Disclosure		

- system number - AKZ or KKS system plant group
- drawing description - Drawing description 1
- drawing description 1 - Drawing description 2
- tdgn_type - Drawing type
- drawing_number - Drawing number (X.XX/XXXXX)
- revision - Current revision number
- The remaining data must be filled in by the draughtsperson in accordance with Clause B.4.5

D.O.	REV	DATE	** REVISION DESCRIPTION **		DRAWN BY	CHKD BY	AUTH BY	CODIF BY	APPR BY	PROF. ENG. INCL. REG. NO.	Q
APPROVED BY :			AUTHORISED BY :		Power Station Name (e.g. Lethabo Power Station)						
INDEX REFERENCE :					Unit Number (e.g. Unit 01)						
DRG REG.	---	---	ESKOM HOLDINGS LTD. REG. No. 2002/015527/06		System Plant Group (AKS or KKS) / Description Description 2						
CODIF BY	---	---			Drawing Type						
CHKD BY	---	---			Drawing Number in accordance with GGS 0445						
REVISION ONLY	---	---			REV						
DRAWN BY	---	---			---						
SCALE	-----				---						
19	20		DRAWING CLASSIFICATION: CONTROLLED DISCLOSURE		SIZE GROOT						
											AOL

Fig. 3

Revision No

6. USING THE TOOLBOXES

- 6.1 PlantSpace P&ID has been customised with standard toolboxes which must be used to create all symbols, lines and tags.
- 6.2 Items which have tagged components must be tagged by selecting the Tag Component tool (Clause D.6.26 refers).



Selecting the Tag Component Tool followed by the item that must be tagged will open the applicable Tag Component Dialog Box:

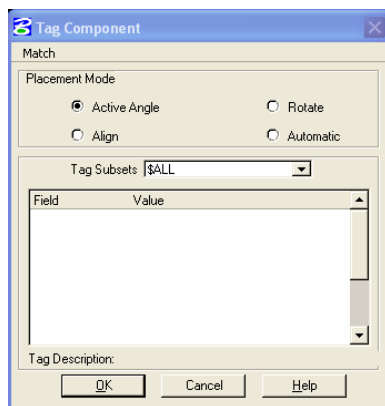

Typical Tag Component Dialog Box

Work Instruction for Process (P&ID, PFD, PPF and SPFD), Hydraulic and Pneumatic Drawings	Unique Identifier:	36-945
	Revision:	0
Classification: Controlled Disclosure	Page:	12 of 117

- 6.3 The "Tag Component" dialog box contains fields that must be placed in close proximity to the tagged item. If this is not possible the Leader Line tool (Clause D.6.2. refers) must be used to draw a line linking the tagged item to the applicable text tag.
- 6.4 Some components have predefined text format place holders which allow tags to be automatically placed if the automatic placement mode is selected in the tag component dialog box. This feature is dependant on the placement of the tagged item and will only function correctly if the tagged item has been inserted correctly.
- 6.5 The applicable fields and values for each Tag Component Dialog Box are specified below.

6.1.1 Piping toolbox

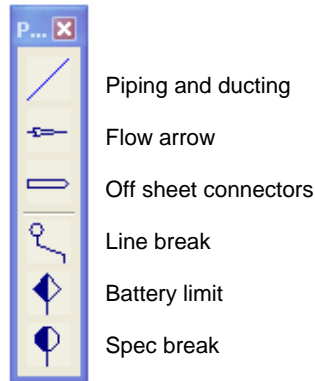

Fig. 5

The following items can be drawn using this toolbox:

Piping and ducting

- General piping
- Insulated piping
- Future/Existing piping
- Jacketed piping
- Ducting

The above items can be drawn as either Primary or Secondary lines.

Tagging



Selecting a Pipe with the tag tool will open the Tag Component [PIPE] Dialog Box. The following values must be filled in by the user:

Field	Value	Value Explanation
drawing no		Drawing number
unique no		Sequential line number per drawing
pipe size		Pipe size
pipe size units		A drop down list indicating the following option: " - Imperial mm - Metric

Once all the required values have been filled in by the user the values must be placed in close proximity to the tagged pipe. Each pipe must only be tagged once. The pipe line tag must be placed in a position where it can be clearly read. Ideally the pipe line tag must be placed close to the start or end of a line. e.g. next to the off-sheet connector.

Work Instruction for Process (P&ID, PFD, PPF and SPFD), Hydraulic and Pneumatic Drawings	Unique Identifier:	36-945
	Revision:	0
Classification: Controlled Disclosure	Page:	13 of 117

Flow arrow tool



This tool must be utilised to indicate the direction of flow of a process stream.

Off sheet connector

This tool must be utilised when Lines span over multiple drawings.

Selecting the off sheet connector tool will open a component settings dialog box which will allow the user to select the following options for placing the off sheet connector.

- Left In - Off sheet connector positioned on the left side of the drawing indicating flow in from another drawing
- Left Out - Off sheet connector positioned on the left side of the drawing indicating flow out to another drawing
- Left Dual - Off sheet connector positioned on the left side of the drawing indicating flow in both directions
- Right In - Off sheet connector positioned on the right side of the drawing indicating flow in from another drawing
- Right Out - Off sheet connector positioned on the right side of the drawing indicating flow out to another drawing
- Right Dual - Off sheet connector positioned on the right side of the drawing indicating flow in both directions

Tagging



Selecting an Off Sheet Connector with the tag tool will open the Tag Component [Off Sheet_Connector] Dialog Box. Tagging the Off Sheet Connector can only be done once the connected drawings have been processed into the project database. The connecting drawing number and connecting line number must be available in the drop down lists in the connected_dgn and connected_line fields. The following values must be filled in by the user:

Field	Value	Explanation
flow_direction		Predefined fields indicating the flow direction: IN OUT DUAL
connected_dgn		Connecting drawing must be available in the drop down list by the user
connected_line		Connecting line must be available in the drop down list by the user
notes1		Description of the connecting off sheet connector
notes2		Description of the connecting off sheet connector

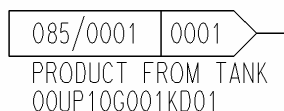

Line break tool

Work Instruction for Process (P&ID, PFD, PPF and SPFD), Hydraulic and Pneumatic Drawings	Unique Identifier:	36-945
	Revision:	0
Classification: Controlled Disclosure	Page:	14 of 117

This tool must only be used in exceptional cases where the user requires a straight line to have more than one line number. The following examples indicate the use of this tool. Note the position of the break created in the line.

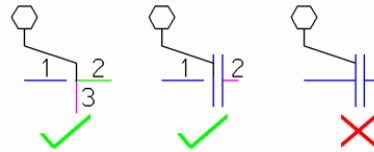

Battery limit tool

This tool must be used to indicate a change in responsibility.

Tagging



Selecting a Battery Limit with the tag tool will open the Tag Component [BatteryLimit] Dialog Box. The following values must be filled in by the user:

Field	Value	Explanation
bat_desc		Field predefined as BATTERY LIMIT
inside_scope		Indicate the included scope limit of the responsible party. Typically the Contractor's name.
outside_scope		Indicate the excluded from scope limit and the corresponding responsible party. Typically this would be Eskom.



Spec break tool

This tool must be used to indicate a change in specification. The following types of Spec Breaks can be selected from a drop down list:

- Material Specification
- Line Specification
- Design Code
- Insulation Specification
- Paint Specification

Tagging



Selecting a Spec Break with the Tag Tool will open the Tag Component [SpecBreak] Dialog Box. The following values must be filled in by the user:

Field	Value	Explanation
spec_desc		A drop down list indicating the type of break as shown above.
spec1		Description indicating the change from condition.
spec2		Description indicating the change to condition.



Work Instruction for Process (P&ID, PFD, PPF and SPFD), Hydraulic and Pneumatic Drawings	Unique Identifier:	36-945
	Revision:	0
Classification: Controlled Disclosure	Page:	15 of 117

6.1.2 Miscellaneous toolbox

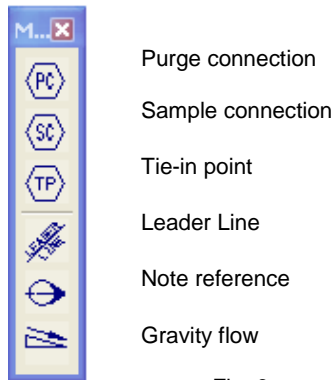

Fig. 6

The following items can be drawn using this toolbox:

Purge connection tool

This tool must be used to indicate a Purge Point.

Sample connection tool

This tool must be used to indicate a Sample Point.

Tie-in point tool

This tool must be used to indicate a Tie-in Point.



Tagging

Selecting a Tie-in Point with the tag tool will open the Tag Component [Tie-In] Dialog Box.

Field	Value	Explanation
tie in number		Unique tie-in number

Note reference tool

This tool must be used to indicate a drawing note.



Tagging

Selecting a Note Reference Point with the tag tool will open the Tag Component [miscellaneous_Note Reference] Dialog Box.

Field	Value	Explanation
note_ref		Unique note reference number. The draughtsperson must fill in the note description in the designated area on the Title Block using the predefined data fields.

Gravity flow tool

This tool can be used to indicate either Gravity Flow or a Slope pipe.

Work Instruction for Process (P&ID, PFD, PPF and SPFD), Hydraulic and Pneumatic Drawings	Unique Identifier:	36-945
	Revision:	0
Classification: Controlled Disclosure	Page:	16 of 117

6.1.3 Hand Valve toolbox

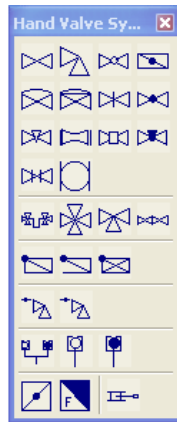

Fig. 7

The following items can be drawn using this toolbox:

- **General Valve Not Specified**
- **Angle Valve**
- **Ball Valve**
- **Butterfly Valve**
- **Diaphragm Valve Bonnet Type**
- **Diaphragm Valve Manual Set**
- **Gate Valve**
- **Globe Valve**
- **Needle Valve**
- **Pinch Valve**
- **Plug Valve**
- **Wedge Gate Valve**
- **Slide Valve**
- **Spherical Valve**
- **Dual Change Over Selector Valve**
- **4 Way Valve**
- **3 Way Valve**
- **Turbine Inlet Valve**
- **Non Return Valve**
- **Non Return Valve Foot Type**
- **Non Return Foot Type with Strainer**
- **Angle Relief Valve Pressure**
- **Angle Relief Valve Vacuum**
- **Air Release Valve Double Orifice**
- **Air Release Valve Large Orifice**
- **Air Release Valve Small Orifice**
- **Volume Control Damper**
- **Fire Control Damper**
- **Sliding Gate**

Tagging



Selecting a Hand Valve with the tag tool will open the Tag Component [Hand Valve] Dialog Box. The following values must be filled in by the user:

Work Instruction for Process (P&ID, PFD, PPF and SPFD), Hydraulic and Pneumatic Drawings	Unique Identifier:	36-945
	Revision:	0
Classification: Controlled Disclosure	Page:	17 of 117

Field	Value	Explanation
valve designation		A drop down list indicating the valve designation. The following options are available: - Hand (default) - Instrument The user must change the tag to instrument if the valve is inserted into an instrument line.
unit number c1		AKZ – Ordinal Section C1 indicating the unit number.
plant group c2		AKZ – Ordinal Section C2 indicating the plant group.
plant section c3		AKZ – Ordinal Section C3 indicating the plant section.
equipment type c4		AKZ – Ordinal Section C4 indicating the type of machine, equipment etc...
unique number u		AKZ – Ordinal Section U indicating the unique number.
component type c6		Third level KKS breakdown.
use_pipe_size		This value should be changed from YES (default) to NO if the valve size is different to that of the pipe line it is installed in.
valve size		If use_pipe_size has been changed to NO the user must fill in the valve size.
status		A drop down list indicating the following option: The default value is blank designating not specified. NO – Normally Open NC – Normally Closed LO – Locked Open LC – Locked Close

6.1.4 Hand Valve Operator toolbox



Fig. 8
The following items can be drawn using this toolbox:

- **Hand Wheel**
- **Hand Wheel with Gearbox**
- **Lever**
- **Weight Assisted Operator**
- **Chain Wheel**

Tagging



Selecting a Hand Valve Operator with the tag tool will open the Tag Component [Hand Valve Operator] Dialog Box. This is an optional tag and only items specifically requested by Eskom should be tagged. The following values can be filled in by the user:

Work Instruction for Process (P&ID, PFD, PPF and SPFD), Hydraulic and Pneumatic Drawings	Unique Identifier:	36-945
	Revision:	0
Classification: Controlled Disclosure	Page:	18 of 117

Field	Value	Explanation
unit number c1		AKZ – Ordinal Section C1 indicating the unit number.
plant group c2		AKZ – Ordinal Section C2 indicating the plant group.
plant section c3		AKZ – Ordinal Section C3 indicating the plant section.
equipment type c4		AKZ – Ordinal Section C4 indicating the type of machine, equipment etc...
unique number u		AKZ – Ordinal Section U indicating the unique number.
component type c6		Third level KKS breakdown.

Indicate Fail Close Position

This tool must be used to indicate the fail position of 3 or 4 way valves.

A 3 way valve will typically have one arrow whereas a 4 way valve could have 2 arrows.

6.1.5 Control Valve toolbox

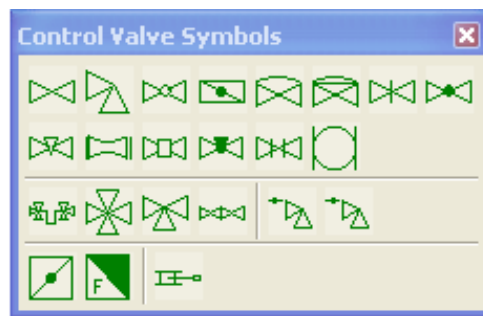

Fig. 9

The following items can be drawn using this toolbox:

- **General Valve No Spec**
- **Angle Valve**
- **Ball Valve**
- **Butterfly Valve**
- **Diaphragm Valve Bonnet Type**
- **Diaphragm Valve Manual Set**
- **Gate Valve**
- **Globe Valve**
- **Needle Valve**
- **Pinch Valve**
- **Plug Valve**
- **Wedge Gate Valve**
- **Slide Valve**
- **Spherical Valve**
- **Dual Change Over Selector Valve**
- **4 Way Valve**
- **3 Way Valve**
- **Turbine Inlet Valve**
- **Angle Relief Valve Pressure**
- **Angle Relief Valve Vacuum**
- **Volume Control Damper**
- **Fire Control Damper**
- **Sliding Gate**

Work Instruction for Process (P&ID, PFD, PPF and SPFD), Hydraulic and Pneumatic Drawings	Unique Identifier:	36-945
	Revision:	0
Classification: Controlled Disclosure	Page:	19 of 117

Tagging



Selecting a Control Valve with the tag tool will open the Tag Component [Control Valve] Dialog Box. The following values must be filled in by the user:

Field	Value	Explanation
unit number c1		AKZ – Ordinal Section C1 indicating the unit number.
plant group c2		AKZ – Ordinal Section C2 indicating the plant group.
plant section c3		AKZ – Ordinal Section C3 indicating the plant section.
equipment type c4		AKZ – Ordinal Section C4 indicating the type of machine, equipment etc...
unique number u		AKZ – Ordinal Section U indicating the unique number.
component type c6		Third level KKS breakdown.
use_pipe_size		This value should be changed from YES (default) to NO if the valve size is different to that of the pipe line it is installed in.
valve size		If use_pipe_size has been changed to NO the user must fill in the valve size.
fail_mode		A drop down list indicating the following option: The default value is blank designating not specified. FO – Fail Open FC – Fail Closed

Special Drawing Requirements

The user must draw the following valves in accordance with the sample below:

- FCV - Flow control
- PCV - Pressure control
- TCV - Temperature control
- LCV - Level control

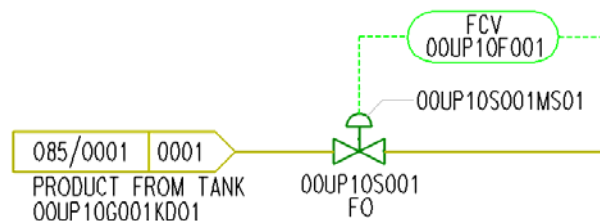

The user must ensure that the control loop contains an instrument bubble showing the type of control valve as indicated above. The instrument bubble must be created to ensure that the control valve is captured in the instrument table in the PDB.

Work Instruction for Process (P&ID, PFD, PPF and SPFD), Hydraulic and Pneumatic Drawings	Unique Identifier:	36-945
	Revision:	0
Classification: Controlled Disclosure	Page:	20 of 117

6.1.6 Control Valve Operator toolbox

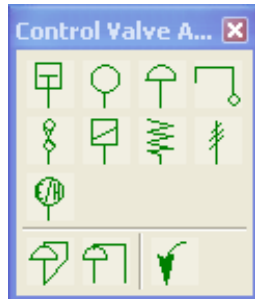

Fig. 10

The following items can be drawn using this toolbox:

- **Piston Operator**
- **Power Operated Unspecified**
- **Diaphragm Operator**
- **Float Operator**
- **Mech. Fusible Link Flame Back**
- **Solenoid Operator**
- **Spring Operator**
- **Pressure Relief or Safety**
- **Electro Hydraulic Operator**
- **Pressure Regulator Self Contained**
- **Pressure Regulator External Tap**

Tagging



Selecting a Control Valve Operator with the tag tool will open the Tag Component [Control Valve Operator] Dialog Box. This is an optional tag and only items specifically requested by Eskom should be tagged. The following values can be filled in by the user:

Field	Value	Explanation
unit number c1		AKZ – Ordinal Section C1 indicating the unit number.
plant group c2		AKZ – Ordinal Section C2 indicating the plant group.
plant section c3		AKZ – Ordinal Section C3 indicating the plant section.
equipment type c4		AKZ – Ordinal Section C4 indicating the type of machine, equipment etc...
unique number u		AKZ – Ordinal Section U indicating the unique number.
component type c6		Third level KKS breakdown.

Indicate Fail Close Position for 3 and 4 Way valves

This tool must be used to indicate the fail position of 3 or 4 way valves.

A 3 way valve will typically have one arrow whereas a 4 way valve could have 2 arrows.

Work Instruction for Process (P&ID, PFD, PPF and SPFD), Hydraulic and Pneumatic Drawings	Unique Identifier:	36-945
	Revision:	0
Classification: Controlled Disclosure	Page:	21 of 117

6.1.7 Piping Fittings, Reducers, Flanges, Couplings and Joints toolbox

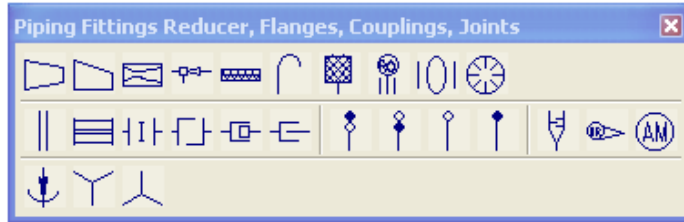

Fig. 11

The following items can be drawn using this toolbox:

- **Concentric Reducer**
- **Eccentric Reducer**

Tagging



Selecting the above Reducers with the tag tool will open the Tag Component [Fitting_Reducer] Dialog Box. The following values can be filled in by the user:

Field	Value	Explanation
size		Primary pipe size.
reducing_size		Secondary pipe size.
size_units		A drop down list indicating the following option: " - Imperial mm - Metric

- Venturi
- Ejector
- Flexible Hose
- Vent
- Vent or Filter
- Restriction Orifice
- Rubber Joint
- Pig Hatch
- Blank Flange
- Flanged Dismantling Joint
- Insulated Block Joint
- Coupling No Spec
- Flexible Hose Connection
- Sliding Expansion Joint
- Open Figure 8 Blind
- Closed Figure 8 Blind
- Spacer
- Blank
- Silencer
- Floor Washing Hose Reel
- Man Hole - Access Way
- Drain Point
- Overflow Tundish
- Bellmouth Outlet

Tagging

Selecting the above Fittings with the tag tool will open the Tag Component [Fitting] Dialog Box. This is an optional tag and only items specifically requested by Eskom should be tagged. The following values can be filled in by the user:

Work Instruction for Process (P&ID, PFD, PPF and SPFD), Hydraulic and Pneumatic Drawings	Unique Identifier:	36-945
	Revision:	0
Classification: Controlled Disclosure	Page:	22 of 117

Field	Value	Explanation
unit number c1		AKZ – Ordinal Section C1 indicating the unit number.
plant group c2		AKZ – Ordinal Section C2 indicating the plant group.
plant section c3		AKZ – Ordinal Section C3 indicating the plant section.
equipment type c4		AKZ – Ordinal Section C4 indicating the type of machine, equipment etc...
unique number u		AKZ – Ordinal Section U indicating the unique number.
component type c6		Third level KKS breakdown.

6.1.8 Fire control system toolbox



Fig. 12

The following items can be drawn using this toolbox:

- **Alarm Valve with Isolator (WET)**
- **Hydrant**
- **Multi Jet Controller**

Tagging



Selecting the above Hand Valves with the tag tool will open the Tag Component [Hand Valve] Dialog Box. The following values must be filled in by the user:

Field	Value	Explanation
valve designation		A drop down list indicating the valve designation. The following options are available: - Hand (default) - Instrument The user must change the tag to instrument if the valve is inserted into an instrument line.
unit number c1		AKZ – Ordinal Section C1 indicating the unit number.
plant group c2		AKZ – Ordinal Section C2 indicating the plant group.
plant section c3		AKZ – Ordinal Section C3 indicating the plant section.
equipment type c4		AKZ – Ordinal Section C4 indicating the type of machine, equipment etc...
unique number u		AKZ – Ordinal Section U indicating the unique number.
component type c6		Third level KKS breakdown.
use_pipe_size		This value should be changed from YES (default) to NO if the valve size is different to that of the pipe line it is installed in.
valve size		If use_pipe_size has been changed to NO the user must fill in the valve size.
Status		A drop down list indicating the following option: The default value is blank designating not specified. NO – Normally Open NC – Normally Closed LO – Locked Open LC – Locked Close

- **Deluge Valve with Isolators (Dry) Air/Water**
- **Deluge Valve with Isolators (Dry) Solenoid**
- **Differential Air Valve with Isolators (Dry)**

Work Instruction for Process (P&ID, PFD, PPF and SPFD), Hydraulic and Pneumatic Drawings	Unique Identifier:	36-945
	Revision:	0
Classification: Controlled Disclosure	Page:	23 of 117

Tagging



Selecting the above Control Valves with the tag tool will open the Tag Component [Control Valve] Dialog Box. The following values must be filled in by the user:

Field	Value	Explanation
unit number c1		AKZ – Ordinal Section C1 indicating the unit number.
plant group c2		AKZ – Ordinal Section C2 indicating the plant group.
plant section c3		AKZ – Ordinal Section C3 indicating the plant section.
equipment type c4		AKZ – Ordinal Section C4 indicating the type of machine, equipment etc...
unique number u		AKZ – Ordinal Section U indicating the unique number.
component type c6		Third level KKS breakdown.
use_pipe_size		This value should be changed from YES (default) to NO if the valve size is different to that of the pipe line it is installed in.
valve size		If use_pipe_size has been changed to NO the user must fill in the valve size.
fail_mode		A drop down list indicating the following option: The default value is blank designating not specified. FO – Fail Open FC – Fail Closed

- **Foam Air Inductor**
- **Foam Concentrate Inductor**
- **Foam Pourer**
- **High Velocity Spray Nozzle**
- **Medium Velocity Spray Nozzle**
- **Sprinkler Head with Glass Bulb**
- **Frangible Bulb Heat Detector**
- **Fire Hose Reel**
- **Water Alarm Gong**

Tagging



Selecting the above Fittings with the tag tool will open the Tag Component [Fitting] Dialog Box. This is an optional tag and only items specifically requested by Eskom should be tagged. The following values can be filled in by the user:

Field	Value	Explanation
unit number c1		AKZ – Ordinal Section C1 indicating the unit number.
plant group c2		AKZ – Ordinal Section C2 indicating the plant group.
plant section c3		AKZ – Ordinal Section C3 indicating the plant section.
equipment type c4		AKZ – Ordinal Section C4 indicating the type of machine, equipment etc...
unique number u		AKZ – Ordinal Section U indicating the unique number.
component type c6		Third level KKS breakdown.

Work Instruction for Process (P&ID, PFD, PPF and SPFD), Hydraulic and Pneumatic Drawings	Unique Identifier:	36-945
	Revision:	0
Classification: Controlled Disclosure	Page:	24 of 117

6.1.9 HVAC toolbox

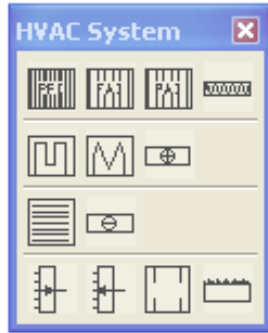

Fig. 13

The following items can be drawn using this toolbox:

- **Pre Air Filter PFI**
- **Air Filter FAI Absolute**
- **Air Filter PAI Iodine**
- **Filter Bank**



Tagging

Selecting the above Equipment types with the tag tool will open the Tag Component [Equip_Vessel] Dialog Box. The following values can be filled in by the user:

Field	Value	Explanation
unit number c1		AKZ – Ordinal Section C1 indicating the unit number.
plant group c2		AKZ – Ordinal Section C2 indicating the plant group.
plant section c3		AKZ – Ordinal Section C3 indicating the plant section.
equipment type c4		AKZ – Ordinal Section C4 indicating the type of machine, equipment etc...
unique number u		AKZ – Ordinal Section U indicating the unique number.
component type c6		Third level KKS breakdown.
equipment name1		Equipment name line 1. The user can specify the descriptive name of the equipment where applicable.
equipment name2		Equipment name line 2. The user can specify the descriptive name of the equipment where applicable.

- **Electrical Air Heater**
- **Steam Air Heater**
- **Heater Bank**
- **Cooling Coil**
- **Cooler**



Tagging

Selecting the above Equipment types with the tag tool will open the Tag Component [Equip_Exchanger] Dialog Box. The following values can be filled in by the user:

Work Instruction for Process (P&ID, PFD, PPF and SPFD), Hydraulic and Pneumatic Drawings	Unique Identifier:	36-945
	Revision:	0
Classification: Controlled Disclosure	Page:	25 of 117

Field	Value	Explanation
unit number c1		AKZ – Ordinal Section C1 indicating the unit number.
plant group c2		AKZ – Ordinal Section C2 indicating the plant group.
plant section c3		AKZ – Ordinal Section C3 indicating the plant section.
equipment type c4		AKZ – Ordinal Section C4 indicating the type of machine, equipment etc...
unique number u		AKZ – Ordinal Section U indicating the unique number.
component type c6		Third level KKS breakdown.
equipment name1		Equipment name line 1. The user can specify the descriptive name of the equipment where applicable.
equipment name2		Equipment name line 2. The user can specify the descriptive name of the equipment where applicable.

- **Air Intake**
- **Air Exhaust**
- **Sound Attenuator**
- **Humidifier**

Tagging



Selecting the above Fitting type with the tag tool will open the Tag Component [Fitting] Dialog Box. This is an optional tag and only items specifically requested by Eskom should be tagged. The following values can be filled in by the user:

Field	Value	Explanation
unit number c1		AKZ – Ordinal Section C1 indicating the unit number.
plant group c2		AKZ – Ordinal Section C2 indicating the plant group.
plant section c3		AKZ – Ordinal Section C3 indicating the plant section.
equipment type c4		AKZ – Ordinal Section C4 indicating the type of machine, equipment etc.
unique number u		AKZ – Ordinal Section U indicating the unique number.
component type c6		Third level KKS breakdown.

6.1.10 Vacuum cleaning system toolbox

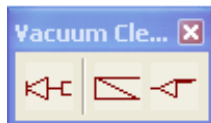

Fig. 14

The following items can be drawn using this toolbox:

- **Vacuum Lines Isolation Valve with Hose Connection**

Tagging



Selecting the above Hand Valve type with the tag tool will open the Tag Component [Hand Valve] Dialog Box. The following values must be filled in by the user:

Work Instruction for Process (P&ID, PFD, PPF and SPFD), Hydraulic and Pneumatic Drawings	Unique Identifier:	36-945
	Revision:	0
Classification: Controlled Disclosure	Page:	26 of 117

Field	Value	Explanation
valve designation		A drop down list indicating the valve designation. The following options are available: - Hand (default) - Instrument The user must change the tag to instrument if the valve is inserted into an instrument line.
unit number c1		AKZ – Ordinal Section C1 indicating the unit number.
plant group c2		AKZ – Ordinal Section C2 indicating the plant group.
plant section c3		AKZ – Ordinal Section C3 indicating the plant section.
equipment type c4		AKZ – Ordinal Section C4 indicating the type of machine, equipment etc...
unique number u		AKZ – Ordinal Section U indicating the unique number.
component type c6		Third level KKS breakdown.
use_pipe_size		This value should be changed from YES (default) to NO if the valve size is different to that of the pipe line it is installed in.
valve size		If use_pipe_size has been changed to NO the user must fill in the valve size.
Status		A drop down list indicating the following option: The default value is blank designating not specified. NO – Normally Open NC – Normally Closed LO – Locked Open LC – Locked Close

- **Vacuum Bulk Transport Connection**
- **Vacuum Standard Cleaning Connection**

Tagging



Selecting the above Fittings with the tag tool will open the Tag Component [Fitting] Dialog Box. This is an optional tag and only items specifically requested by Eskom should be tagged. The following values can be filled in by the user:

Field	Value	Explanation
unit number c1		AKZ – Ordinal Section C1 indicating the unit number.
plant group c2		AKZ – Ordinal Section C2 indicating the plant group.
plant section c3		AKZ – Ordinal Section C3 indicating the plant section.
equipment type c4		AKZ – Ordinal Section C4 indicating the type of machine, equipment etc...
unique number u		AKZ – Ordinal Section U indicating the unique number.
component type c6		Third level KKS breakdown.

Work Instruction for Process (P&ID, PFD, PPF and SPFD), Hydraulic and Pneumatic Drawings	Unique Identifier:	36-945
	Revision:	0
Classification: Controlled Disclosure	Page:	27 of 117

6.1.11 Instrumentation toolbox

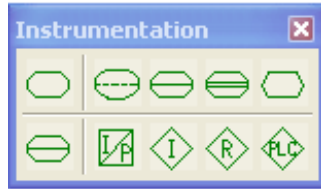

Fig. 15

The following items can be drawn using this toolbox:

- **Local Mounted Instrument**
- **Mounted on Instrument Auxiliary Panel**
- **Mounted on Instrument Panel in Control Room**
- **Mounted on Local Instrument Panel or Control Box**
- **VDU Display – Computer**
- **Future**
- **Electro-Pneumatic Converter**
- **Electrical Interface**
- **Logic Binary Control**
- **Programmable Logic Controller (PLC)**

Tagging

Selecting an Instrument Bubble with the tag tool will open the Tag Component [Instrument] Dialog Box. The following values must be filled in by the user:

Field	Value	Explanation
unit number c1		AKZ – Ordinal Section C1 indicating the unit number.
plant group c2		AKZ – Ordinal Section C2 indicating the plant group.
plant section c3		AKZ – Ordinal Section C3 indicating the plant section.
equipment type c4		AKZ – Ordinal Section C4 indicating the type of machine, equipment etc...
unique number u		AKZ – Ordinal Section U indicating the unique number.
isa abbreviation		ISA abbreviation giving the description of the type of instrument.
cable identifier		This option must only be filled in by the user where multiple alarm conditions occur and the tags can not be uniquely identified by using the C1,C2,C3,C4,U and ISA abbreviation.
modifier1		Field to provide additional information to clarify monitoring equipment. Typically for analysers the following values must be filled in by the user: TURB – Turbidity Na- Sodium SiO ₂ – Silica O ₂ – Oxygen H ₂ – Hydrogen SF ₆ – Sulphur Hexafluoride μS – Conductivity SG – Density VISC – Viscosity MOIST-Moisture
modifier2		Descriptive information field.
modifier3		Descriptive information field.

Work Instruction for Process (P&ID, PFD, PPF and SPFD), Hydraulic and Pneumatic Drawings	Unique Identifier:	36-945
	Revision:	0
Classification: Controlled Disclosure	Page:	28 of 117

Special Drawing Requirements

The draughtsperson must position tags for instrumentation bubbles as indicated below:

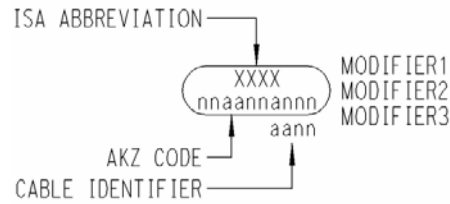

ISA abbreviations and possible modifiers are listed below. The user must concatenate Level1 followed by Level 2, 3 and 4 if applicable to build up the functionality of the require instrument (see table below).

Symbol	Level 1	Modifier	Level 2	Level 3	Level 4
A	Analysis	-	Alarm	-	-
B	Burner Flame	-	Users Choice	Users Choice	Users Choice
C	Users Choice	-	Control	Control	-
D	Users Choice	Differential	-	-	-
E	Voltage (EMF)	-	Primary Elem	-	-
F	Flow Rate	Ratio Fraction	-	-	-
G	Gauge (Dimensional)	-	Glass	-	-
H	Hand (Manual)	-	-	High	High
I	Current (Electrical)	-	Indicate	-	-
J	Power	Scan	-	-	-
K	Time or Time Schedule	Time Rate of Change	-	Control Station	-
L	Level	-	Light (Pilot)	Low	Low
M	Users Choice	Momentary	-	Middle or Intermediate	Middle or Intermediate
N	Users Choice	-	Users Choice	Users Choice	Users Choice
O	Users Choice	-	Orifice (Restriction)	-	-
P	Pressure or Vacuum	-	Point (Test Connection)	-	-
Q	Quantity or Event	Integrate or Totalise	Totalise	Totalise	-
R	Radioactivity	-	Record/Print	-	-
S	Speed or Frequency	Safety	Switch	Switch	-
T	Temperature	-	-	Transmit	-
U	Multivariable	-	Multifunction	Multifunction	Multifunction
V	Vibration	-	-	Valve, Damper or Louvre	-
W	Weight or Force	-	Well	-	-
X	Unclassified	X Axis	Unclassified	Unclassified	Unclassified
Y	Event, State or Presence	Y Axis	-	Relay or Compute	-

Work Instruction for Process (P&ID, PFD, PPF and SPFD), Hydraulic and Pneumatic Drawings	Unique Identifier:	36-945
	Revision:	0
Classification: Controlled Disclosure	Page:	29 of 117

Z	Position Dimension	Z Axis	-	Drive, Actuate or Unclassified Final Control Element	-
----------	--------------------	--------	---	--	---

6.12 Instrument Lines toolbox

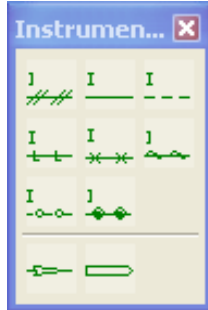

Fig. 16

The following items can be drawn using this toolbox:

- **Pneumatic Signal**
- **Instrument Supply or Connection to Process**
- **Electric Signal**
- **Hydraulic Signal**
- **Capillary Tube**
- **Electromagnetic, Sonic, Optical or Nuclear Signal**
- **Software or Data Link**
- **Mechanical Line**
- **Instrument Line Flow Arrow**
- **Off Sheet Connector for Instrument Lines**

This tool must be utilised when lines span over multiple drawings.

Selecting the Off Sheet Connector tool will open a component settings dialog box which will allow the user to select the following options for placing the off sheet connector.

- **Left In** – Off sheet connector positioned on the left side of the drawing indicating flow in from another drawing
- **Left Out** – Off sheet connector positioned on the left side of the drawing indicating flow out to another drawing
- **Left Dual** – Off sheet connector positioned on the left side of the drawing indicating flow in both directions
- **Right In** – Off sheet connector positioned on the right side of the drawing indicating flow in from another drawing
- **Right Out** – Off sheet connector positioned on the right side of the drawing indicating flow out to another drawing
- **Right Dual** – Off sheet connector positioned on the right side of the drawing indicating flow in both directions

Tagging



Selecting an Off Sheet Connector with the tag tool will open the Tag Component [Off Sheet_Connector] Dialog Box. Tagging the Off Sheet Connector can only be done once the connected drawings have been processed into the project database. The connecting drawing number and connecting line number must be available in the drop down lists in the connected_dgn and connected_line fields. The following values must be filled in by the user:

Work Instruction for Process (P&ID, PFD, PPF and SPFD), Hydraulic and Pneumatic Drawings	Unique Identifier:	36-945
	Revision:	0
Classification: Controlled Disclosure	Page:	30 of 117

Field	Value	Explanation
connected_dgn		Connecting drawing must be available in the drop down list for selection by the user.
connected_line		Connecting line must be available in the drop down list for selection by the user.
note1		Description of the connecting off sheet connector.
note2		Description of the connecting off sheet connector.

6.13 Inline instrument toolbox



Fig. 17

The following items can be drawn using this toolbox:

- **Unspecified Flow Element**
- **Annubar Flow Element**
- **Magnetic Flow Element**
- **Orifice Flow Element**
- **Pressure Recovery Tube**
- **Turbine Flow Element**
- **Ultrasonic Flow Element**
- **V-Notch Weir Flow Element**
- **Density Recorder**
- **Sight Glass**

Tagging



Selecting the above In-line Instruments with the tag tool will open the Tag Component [Instrument_Flow] Dialog Box. The following values must be filled in by the user:

Field	Value	Explanation
unit number c1		AKZ – Ordinal Section C1 indicating the unit number.
plant group c2		AKZ – Ordinal Section C2 indicating the plant group.
plant section c3		AKZ – Ordinal Section C3 indicating the plant section.
equipment type c4		AKZ – Ordinal Section C4 indicating the type of machine, equipment etc...
unique number u		AKZ – Ordinal Section U indicating the unique number.
isa abbreviation		ISA abbreviation describing the type of instrument.

Work Instruction for Process (P&ID, PFD, PPF and SPFD), Hydraulic and Pneumatic Drawings	Unique Identifier:	36-945
	Revision:	0
Classification: Controlled Disclosure	Page:	31 of 117

6.1.14 Pump toolbox



Fig. 18

The following items can be drawn using this toolbox:

- **Basic Unspecified Pump**
- **Centrifugal Pump**
- **Vacuum Pump**
- **Diaphragm Pump**
- **Gear Pump**
- **Rotary Pump**
- **Piston Pump**
- **Progressive Cavity Pump**
- **Vertical Spindle Pump**

Tagging



Selecting the above Equipment with the tag tool will open the Tag Component [Equip_Pump] Dialog Box. The following values can be filled in by the user:

Field	Value	Explanation
unit number c1		AKZ – Ordinal Section C1 indicating the unit number.
plant group c2		AKZ – Ordinal Section C2 indicating the plant group.
plant section c3		AKZ – Ordinal Section C3 indicating the plant section.
equipment type c4		AKZ – Ordinal Section C4 indicating the type of machine, equipment etc...
unique number u		AKZ – Ordinal Section U indicating the unique number.
component type c6		Third level KKS breakdown.
equipment name1		Equipment name line 1. The user can specify a descriptive name for the applicable equipment.
equipment name2		Equipment name line 2. The user can specify a descriptive name for the applicable equipment.

Work Instruction for Process (P&ID, PFD, PPF and SPFD), Hydraulic and Pneumatic Drawings	Unique Identifier:	36-945
	Revision:	0
Classification: Controlled Disclosure	Page:	32 of 117

6.1.15 Fans, Blowers and Compressors toolbox



Fig. 19

The following items can be drawn using this toolbox:

- **Centrifugal Fan**
- **Forced Draft Fan**
- **Induced Draft Fan**
- **Primary Air Fan**
- **Compressor**
- **Roots Blower**



Tagging

Selecting the above Equipment with the tag tool will open the Tag Component [Equip_Fan] Dialog Box. The following values can be filled in by the user:

Field	Value	Explanation
unit number c1		AKZ – Ordinal Section C1 indicating the unit number.
plant group c2		AKZ – Ordinal Section C2 indicating the plant group.
plant section c3		AKZ – Ordinal Section C3 indicating the plant section.
equipment type c4		AKZ – Ordinal Section C4 indicating the type of machine, equipment etc...
unique number u		AKZ – Ordinal Section U indicating the unique number.
component type c6		Third level KKS breakdown.
equipment name1		Equipment name line 1. The user can specify a descriptive name for the applicable equipment.
equipment name2		Equipment name line 2. The user can specify a descriptive name for the applicable equipment.

Work Instruction for Process (P&ID, PFD, PPF and SPFD), Hydraulic and Pneumatic Drawings	Unique Identifier:	36-945
	Revision:	0
Classification: Controlled Disclosure	Page:	33 of 117

6.1.16 Turbine toolbox



Fig. 20

The following items can be drawn using this toolbox:

- **Single Steam - Gas - Water Turbine**
- **Double Steam - Gas - Water Turbine**
- **Pump / Turbine**
- **Generator**

Tagging



Selecting the above Equipment with the tag tool will open the Tag Component [Equip_Turbine] Dialog Box. The following values can be filled in by the user:

Field	Value	Explanation
unit number c1		AKZ – Ordinal Section C1 indicating the unit number.
plant group c2		AKZ – Ordinal Section C2 indicating the plant group.
plant section c3		AKZ – Ordinal Section C3 indicating the plant section.
equipment type c4		AKZ – Ordinal Section C4 indicating the type of machine, equipment etc...
unique number u		AKZ – Ordinal Section U indicating the unique number.
component type c6		Third level KKS breakdown.
equipment name1		Equipment name line 1. The user can specify a descriptive name for the applicable equipment.
equipment name2		Equipment name line 2. The user can specify a descriptive name for the applicable equipment.

6.1.17 Drive toolbox



Fig. 21

Work Instruction for Process (P&ID, PFD, PPF and SPFD), Hydraulic and Pneumatic Drawings	Unique Identifier:	36-945
	Revision:	0
Classification: Controlled Disclosure	Page:	34 of 117

The following items can be drawn using this toolbox:

- **Electric Driver**
- **Air Driver**
- **Diesel Driver**
- **Petrol Drive**

Tagging



Selecting the above Equipment with the tag tool will open the Tag Component [Equip_Driver] Dialog Box. The following values can be filled in by the user:

Field	Value	Explanation
unit number c1		AKZ – Ordinal Section C1 indicating the unit number.
plant group c2		AKZ – Ordinal Section C2 indicating the plant group.
plant section c3		AKZ – Ordinal Section C3 indicating the plant section.
equipment type c4		AKZ – Ordinal Section C4 indicating the type of machine, equipment etc...
unique number u		AKZ – Ordinal Section U indicating the unique number.
component type c6		Third level KKS breakdown.
equipment name1		Equipment name line 1. The user can specify a descriptive name for the applicable equipment.
equipment name2		Equipment name line 2. The user can specify a descriptive name for the applicable equipment.

6.1.18 Heat Exchanger and Condensers toolbox

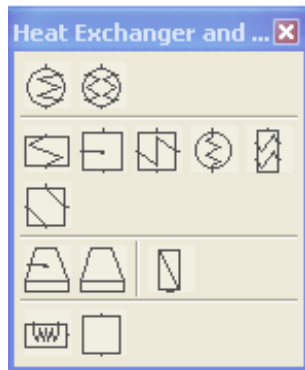

Fig. 22

The following items can be drawn using this toolbox:

- **Surface Condensers**
- **Surface Condensers Divided on Water Side**

Tagging



Selecting the above Equipment with the tag tool will open the Tag Component [Equip_Condenser] Dialog Box. The following values can be filled in by the user:

Work Instruction for Process (P&ID, PFD, PPF and SPFD), Hydraulic and Pneumatic Drawings	Unique Identifier:	36-945
	Revision:	0
Classification: Controlled Disclosure	Page:	35 of 117

Field	Value	Explanation
unit number c1		AKZ – Ordinal Section C1 indicating the unit number.
plant group c2		AKZ – Ordinal Section C2 indicating the plant group.
plant section c3		AKZ – Ordinal Section C3 indicating the plant section.
equipment type c4		AKZ – Ordinal Section C4 indicating the type of machine, equipment etc...
unique number u		AKZ – Ordinal Section U indicating the unique number.
component type c6		Third level KKS breakdown.
equipment name1		Equipment name line 1. The user can specify a descriptive name for the applicable equipment.
equipment name2		Equipment name line 2. The user can specify a descriptive name for the applicable equipment.

- **Super Heater / Reheater / Economiser**
- **Feed Water Heater**
- **Feed Water Heater, De Superheater, Attemporator or Water Cooler**
- **Sample Cooler**
- **Main Air Heaters**
- **Main Pre Heaters**
- **Wet Cooling Tower**
- **Dry Cooling Tower**
- **Evaporator**
- **General Heat Exchanger**
- **Boiler**

Tagging



Selecting the above Equipment with the tag tool will open the Tag Component [Equip_Exchanger] Dialog Box. The following values can be filled in by the user:

Field	Value	Explanation
unit number c1		AKZ – Ordinal Section C1 indicating the unit number.
plant group c2		AKZ – Ordinal Section C2 indicating the plant group.
plant section c3		AKZ – Ordinal Section C3 indicating the plant section.
equipment type c4		AKZ – Ordinal Section C4 indicating the type of machine, equipment etc...
unique number u		AKZ – Ordinal Section U indicating the unique number.
component type c6		Third level KKS breakdown.
equipment name1		Equipment name line 1. The user can give the descriptive name of the applicable equipment.
equipment name2		Equipment name line 2. The user can give the descriptive name of the applicable equipment.

Work Instruction for Process (P&ID, PFD, PPF and SPFD), Hydraulic and Pneumatic Drawings	Unique Identifier:	36-945
	Revision:	0
Classification: Controlled Disclosure	Page:	36 of 117

6.1.19 Vessels and Tanks toolbox

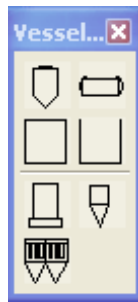

Fig. 23

The following items can be drawn using this toolbox:

- **Vertical Storage Tank Conical Bottom**
- **Horizontal Storage Tank**
- **Storage Tank Closed Top**
- **Storage Tank Open Top**
- **Air Drier**
- **Cyclone**
- **Dust Collectors – Precipitators**

Tagging



Selecting the above Equipment with the tag tool will open the Tag Component [Equip_Vessel] Dialog Box. The following values can be filled in by the user:

Field	Value	Explanation
unit number c1		AKZ – Ordinal Section C1 indicating the unit number.
plant group c2		AKZ – Ordinal Section C2 indicating the plant group.
plant section c3		AKZ – Ordinal Section C3 indicating the plant section.
equipment type c4		AKZ – Ordinal Section C4 indicating the type of machine, equipment etc...
unique number u		AKZ – Ordinal Section U indicating the unique number.
component type c6		Third level KKS breakdown.
equipment name1		Equipment name line 1. The user can give the descriptive name of the applicable equipment.
equipment name2		Equipment name line 2. The user can give the descriptive name of the applicable equipment.

Work Instruction for Process (P&ID, PFD, PPF and SPFD), Hydraulic and Pneumatic Drawings	Unique Identifier:	36-945
	Revision:	0
Classification: Controlled Disclosure	Page:	37 of 117

6.1.20 Miscellaneous Equipment toolbox

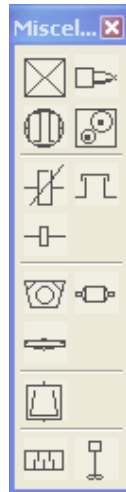

Fig. 24

The following items can be drawn using this toolbox:

- Bearing**

Tagging



Selecting the above Equipment with the tag tool will open the Tag Component [Equip_Bearing] Dialog Box. The following values can be filled in by the user:

Field	Value	Explanation
unit number c1		AKZ – Ordinal Section C1 indicating the unit number.
plant group c2		AKZ – Ordinal Section C2 indicating the plant group.
plant section c3		AKZ – Ordinal Section C3 indicating the plant section.
equipment type c4		AKZ – Ordinal Section C4 indicating the type of machine, equipment etc...
unique number u		AKZ – Ordinal Section U indicating the unique number.
component type c6		Third level KKS breakdown.
equipment name1		Equipment name line 1. The user can give the descriptive name of the applicable equipment.
equipment name2		Equipment name line 2. The user can give the descriptive name of the applicable equipment.

- Burner**

Tagging



Selecting the above Equipment with the tag tool will open the Tag Component [Equip_Burner] Dialog Box. The following values can be filled in by the user:

Work Instruction for Process (P&ID, PFD, PPF and SPFD), Hydraulic and Pneumatic Drawings	Unique Identifier:	36-945
	Revision:	0
Classification: Controlled Disclosure	Page:	38 of 117

Field	Value	Explanation
unit number c1		AKZ – Ordinal Section C1 indicating the unit number.
plant group c2		AKZ – Ordinal Section C2 indicating the plant group.
plant section c3		AKZ – Ordinal Section C3 indicating the plant section.
equipment type c4		AKZ – Ordinal Section C4 indicating the type of machine, equipment etc...
unique number u		AKZ – Ordinal Section U indicating the unique number.
component type c6		Third level KKS breakdown.
equipment name1		Equipment name line 1. The user must give the descriptive name of the applicable equipment.
equipment name2		Equipment name line 2. The user must give the descriptive name of the applicable equipment.

- **Brake**

Tagging



Selecting the above Equipment with the tag tool will open the Tag Component [Equip_Break] Dialog Box. The following values can be filled in by the user:

Field	Value	Explanation
unit number c1		AKZ – Ordinal Section C1 indicating the unit number.
plant group c2		AKZ – Ordinal Section C2 indicating the plant group.
plant section c3		AKZ – Ordinal Section C3 indicating the plant section.
equipment type c4		AKZ – Ordinal Section C4 indicating the type of machine, equipment etc...
unique number u		AKZ – Ordinal Section U indicating the unique number.
component type c6		Third level KKS breakdown.
equipment name1		Equipment name line 1. The user can give the descriptive name of the applicable equipment.
equipment name2		Equipment name line 2. The user can give the descriptive name of the applicable equipment.

Work Instruction for Process (P&ID, PFD, PPF and SPFD), Hydraulic and Pneumatic Drawings	Unique Identifier:	36-945
	Revision:	0
Classification: Controlled Disclosure	Page:	39 of 117

- **Gearbox**

Tagging



Selecting the above Equipment with the tag tool will open the Tag Component [Equip_Gearbox] Dialog Box. The following values can be filled in by the user:

Field	Value	Explanation
unit number c1		AKZ – Ordinal Section C1 indicating the unit number.
plant group c2		AKZ – Ordinal Section C2 indicating the plant group.
plant section c3		AKZ – Ordinal Section C3 indicating the plant section.
equipment type c4		AKZ – Ordinal Section C4 indicating the type of machine, equipment etc...
unique number u		AKZ – Ordinal Section U indicating the unique number.
component type c6		Third level KKS breakdown.
equipment name1		Equipment name line 1. The user can give the descriptive name of the applicable equipment.
equipment name2		Equipment name line 2. The user can give the descriptive name of the applicable equipment.

- **Variable Speed Control Coupling**
- **Clutch Coupling**
- **General Mechanical Coupling**

Tagging



Selecting equipment with the tag tool will open the Tag Component [Equip_Coupling No Spec] Dialog Box. The following values can be filled in by the user:

Field	Value	Explanation
unit number c1		AKZ – Ordinal Section C1 indicating the unit number.
plant group c2		AKZ – Ordinal Section C2 indicating the plant group.
plant section c3		AKZ – Ordinal Section C3 indicating the plant section.
equipment type c4		AKZ – Ordinal Section C4 indicating the type of machine, equipment etc...
unique number u		AKZ – Ordinal Section U indicating the unique number.
component type c6		Third level KKS breakdown.
equipment name1		Equipment name line 1. The user can give the descriptive name of the applicable equipment.
equipment name2		Equipment name line 2. The user can give the descriptive name of the applicable equipment.

- **Drum Mill**
- **General Mill**
- **Thickener**

Tagging



Selecting the above Equipment with the tag tool will open the Tag Component [Equip_Mill] Dialog Box. The following values can be filled in by the user:

Work Instruction for Process (P&ID, PFD, PPF and SPFD), Hydraulic and Pneumatic Drawings	Unique Identifier:	36-945
	Revision:	0
Classification: Controlled Disclosure	Page:	40 of 117

Field	Value	Explanation
unit number c1		AKZ – Ordinal Section C1 indicating the unit number.
plant group c2		AKZ – Ordinal Section C2 indicating the plant group.
plant section c3		AKZ – Ordinal Section C3 indicating the plant section.
equipment type c4		AKZ – Ordinal Section C4 indicating the type of machine, equipment etc...
unique number u		AKZ – Ordinal Section U indicating the unique number.
component type c6		Third level KKS breakdown.
equipment name1		Equipment name line 1. The user must give the descriptive name of the applicable equipment.
equipment name2		Equipment name line 2. The user must give the descriptive name of the applicable equipment.

- **Centrifuge**

Tagging



Selecting the above Equipment with the tag tool will open the Tag Component [Equip_Special] Dialog Box. The following values can be filled in by the user:

Field	Value	Explanation
unit number c1		AKZ – Ordinal Section C1 indicating the unit number.
plant group c2		AKZ – Ordinal Section C2 indicating the plant group.
plant section c3		AKZ – Ordinal Section C3 indicating the plant section.
equipment type c4		AKZ – Ordinal Section C4 indicating the type of machine, equipment etc...
unique number u		AKZ – Ordinal Section U indicating the unique number.
component type c6		Third level KKS breakdown.
equipment name1		Equipment name line 1. The user can give the descriptive name of the applicable equipment.
equipment name2		Equipment name line 2. The user can give the descriptive name of the applicable equipment.

- **Static Mixer**
- **Agitator**

Work Instruction for Process (P&ID, PFD, PPF and SPFD), Hydraulic and Pneumatic Drawings	Unique Identifier:	36-945
	Revision:	0
Classification: Controlled Disclosure	Page:	41 of 117

Tagging



Selecting the above Equipment with the tag tool will open the Tag Component [Equip_Mixer] Dialog Box. The following Values can be filled in by the user:

Field	Value	Explanation
unit number c1		AKZ – Ordinal Section C1 indicating the unit number.
plant group c2		AKZ – Ordinal Section C2 indicating the plant group.
plant section c3		AKZ – Ordinal Section C3 indicating the plant section.
equipment type c4		AKZ – Ordinal Section C4 indicating the type of machine, equipment etc...
unique number u		AKZ – Ordinal Section U indicating the unique number.
component type c6		Third level KKS breakdown.
equipment name1		Equipment name line 1. The user can give the descriptive name of the applicable equipment.
equipment name2		Equipment name line 2. The user can give the descriptive name of the applicable equipment.

6.1.21 Strainers, Filters, Traps, Receivers Toolbox

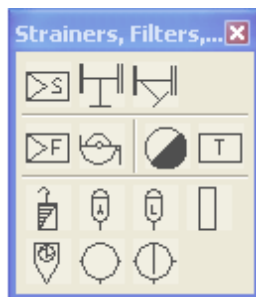

Fig. 25

The following items can be drawn using this toolbox:

- **General Strainer**
- **T-Type Strainer**
- **Y-Type Strainer**
- **General Filter**
- **Drum Filter**
- **Steam Trap**
- **Air Trap**
- **Absorber or Air Drier**
- **Accumulator**
- **Mist Lubricator**
- **Flash Box**
- **Precipitator**
- **Steam Receiver**
- **Steam Separator**

Tagging

Work Instruction for Process (P&ID, PFD, PPF and SPFD), Hydraulic and Pneumatic Drawings	Unique Identifier:	36-945
	Revision:	0
Classification: Controlled Disclosure	Page:	42 of 117



Selecting the above Equipment with the tag tool will open the Tag Component [Equip_Vessel] Dialog Box. The following values can be filled in by the user:

Field	Value	Explanation
unit number c1		AKZ – Ordinal Section C1 indicating the unit number.
plant group c2		AKZ – Ordinal Section C2 indicating the plant group.
plant section c3		AKZ – Ordinal Section C3 indicating the plant section.
equipment type c4		AKZ – Ordinal Section C4 indicating the type of machine, equipment etc...
unique number u		AKZ – Ordinal Section U indicating the unique number.
component type c6		Third level KKS breakdown.
equipment name1		Equipment name line 1. The user can give the descriptive name of the applicable equipment.
equipment name2		Equipment name line 2. The user can give the descriptive name of the applicable equipment.

6.1.22 Conveyor Toolbox



Fig. 26

The following items can be drawn using this toolbox:

- **Belt Conveyor**
- **Screw Take-up**
- **Apron Feeder**
- **Belt Filter**
- **Scraper Conveyor**
- **Tripper Conveyor**
- **Vertical Up Conveyor**
- **Bucket Elevator**
- **Screw Feeder**
- **Vibrating Feeder**
- **Table Feeder**
- **Idlers**

Work Instruction for Process (P&ID, PFD, PPF and SPFD), Hydraulic and Pneumatic Drawings	Unique Identifier:	36-945
	Revision:	0
Classification: Controlled Disclosure	Page:	43 of 117

Tagging



Selecting the above Equipment with the tag tool will open the Tag Component [Equip_Conveyor] Dialog Box. The following values can be filled in by the user:

Field	Value	Explanation
unit number c1		AKZ – Ordinal Section C1 indicating the unit number.
plant group c2		AKZ – Ordinal Section C2 indicating the plant group.
plant section c3		AKZ – Ordinal Section C3 indicating the plant section.
equipment type c4		AKZ – Ordinal Section C4 indicating the type of machine, equipment etc...
unique number u		AKZ – Ordinal Section U indicating the unique number.
component type c6		Third level KKS breakdown.
equipment name1		Equipment name line 1. The user can give the descriptive name of the applicable equipment.
equipment name2		Equipment name line 2. The user can give the descriptive name of the applicable equipment.

6.1.23 Ash and Coal General Toolbox

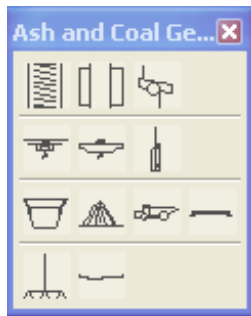

Fig. 27

The following items can be drawn using this toolbox:

- **Demagnetising Coil**
- **Magnetising Coil**
- **Grizzly Feeder**
- **Mono Rail**
- **Over Head Travelling Crane**
- **Skip Hoist**

Work Instruction for Process (P&ID, PFD, PPF and SPFD), Hydraulic and Pneumatic Drawings	Unique Identifier:	36-945
	Revision:	0
Classification: Controlled Disclosure	Page:	44 of 117

Tagging



Selecting a Mono Rail, Over Head Travelling Crane or the Skip Hoist with the tag tool will open the Tag Component [Equip_Lifting] Dialog Box. The following values can be filled in by the user:

Field	Value	Explanation
unit number c1		AKZ – Ordinal Section C1 indicating the unit number.
plant group c2		AKZ – Ordinal Section C2 indicating the plant group.
plant section c3		AKZ – Ordinal Section C3 indicating the plant section.
equipment type c4		AKZ – Ordinal Section C4 indicating the type of machine, equipment etc...
unique number u		AKZ – Ordinal Section U indicating the unique number.
component type c6		Third level KKS breakdown.
equipment name1		Equipment name line 1. The user can give the descriptive name of the applicable equipment.
equipment name2		Equipment name line 2. The user can give the descriptive name of the applicable equipment.

- **General Skip**
- **Stock Pile**
- **Rear Dump Truck**
- **Weigh Bridge**
- **Sprays**
- **Sump**

6.1.24 Hydraulic Equipment Toolbox



Fig. 28

The following items can be drawn using this toolbox:

- **Single Acting Hydraulic Actuator**
- **Double Acting Hydraulic Actuator**
- **Double Acting Hydraulic Actuator with Dif. Act Areas**
- **Actuator or Hydraulic Motor with Alt. Directions of Flow**

Work Instruction for Process (P&ID, PFD, PPF and SPFD), Hydraulic and Pneumatic Drawings	Unique Identifier:	36-945
	Revision:	0
Classification: Controlled Disclosure	Page:	45 of 117

Tagging



Selecting the above Equipment with the tag tool will open the Tag Component [Equip_Hydraulic] Dialog Box. The following values can be filled in by the user:

Field	Value	Explanation
unit number c1		AKZ – Ordinal Section C1 indicating the unit number.
plant group c2		AKZ – Ordinal Section C2 indicating the plant group.
plant section c3		AKZ – Ordinal Section C3 indicating the plant section.
equipment type c4		AKZ – Ordinal Section C4 indicating the type of machine, equipment etc...
unique number u		AKZ – Ordinal Section U indicating the unique number.
component type c6		Third level KKS breakdown.
equipment name1		Equipment name line 1. The user can give the descriptive name of the applicable equipment.
equipment name2		Equipment name line 2. The user can give the descriptive name of the applicable equipment.

6.1.25 Assemblies Toolbox

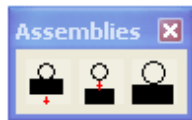

Fig. 29

The following tools can be used to group and place items that the user requires to place repetitively. The individual assembly components must be created using the standard toolboxes specified in this standard.

- **Place Component Assembly**
- **Create Component Assembly**
- **Manage Component Assemblies**

6.1.26 Component Utilities Toolbox



Fig. 30

- **Delete Component**

This tool must be utilised to delete components in PlantSpace P&ID.

Work Instruction for Process (P&ID, PFD, PPF and SPFD), Hydraulic and Pneumatic Drawings	Unique Identifier:	36-945
	Revision:	0
Classification: Controlled Disclosure	Page:	46 of 117

- **Copy Component**
This tool must be utilised to copy components in PlantSpace P&ID.
- **Move Component**
This tool must be utilised to move components in PlantSpace P&ID.
- **Tag Component**
This tool must be utilised to tag components in PlantSpace P&ID.
- **Break Line**
This tool must be utilised to break lines crossing over another line in PlantSpace P&ID. The gap that is created has been defined in PlantSpace P&ID. The user is not allowed to change this gap size.
- **Identify Component**
This tool can be utilised to identify components.

7. CHECKING OF PFD'S AND P&ID'S

7.1 Checking of PFD's and P&ID's using PlantSpace P&ID.

PlantSpace P&ID has a standard toolbox which must be used to check that all components comply with the standard text and settings manager settings once the drawing has been drawn.

7.1.1 Display Components Toolbox



Fig. 31

- **Show Valid Components**
This tool must be utilised to show the valid cells placed in a PFD or P&ID and can be used as the first check when verifying drawing content. All the items that are highlighted on selection of this tool conform to the predefined graphical attributes and settings in the settings manager of PlantSpace P&ID and are valid components.
- **Show Components Not Valid**
This tool must be utilised to show the invalid cells placed in a PFD or P&ID and can be used as the first check when verifying drawing content. All the items that are highlighted on selection of this tool do not conform to the predefined graphical attributes and settings in the settings manager of PlantSpace P&ID and are non-valid components. These components must be deleted and replaced with valid P&ID components.

Work Instruction for Process (P&ID, PFD, PPF and SPFD), Hydraulic and Pneumatic Drawings	Unique Identifier:	36-945
	Revision:	0
Classification: Controlled Disclosure	Page:	47 of 117

The following items would be acceptable non-valid components:

- Title Blocks
- All text components in the Title Block area filled in using the data fields

- **Show Tagged Elements**

This tool must be utilised to show the valid tagged items placed in a PFD or P&ID and can be used as the first check when verifying the drawing tagged items. All the items that are highlighted on selection of this tool conform to the tag settings of PlantSpace P&ID and are valid tagged components.

- **Show Un-Tagged Elements**

This tool must be utilised to show the untagged items placed in a PFD or P&ID and can be used as the first check when verifying the drawing tagged items. All the items that are highlighted on selection of this tool do not conform to the tag settings of PlantSpace P&ID and are non valid tagged components. These components must be tagged.

The following items would be acceptable un-tagged elements:

- Title Blocks
- All text components in the Title Block area filled in using the data fields

- **Show Equipment Components**

This tool can be utilised to show valid equipment items placed in a PFD or P&ID.

- **Show Instrumentation Components**

This tool can be utilised to show valid instrumentation placed in a PFD or P&ID.

- **Show Piping Components**

This tool can be utilised to show valid piping components placed in a PFD or P&ID.

- **Show Valves**

This tool can be utilised to show valid valves placed in a PFD or P&ID.

7.1.2 Processing Drawings and Checking Results

Once a PFD or P&ID has been checked in accordance with Clause 7.1.1 the drawing must be processed. The following steps must be taken to process the PFD or P&ID:

- Select "P&ID", "Process", "Process Drawing" from the menu.
- This will open the "Process Drawings" dialog box.

Work Instruction for Process (P&ID, PFD, PPF and SPFD), Hydraulic and Pneumatic Drawings	Unique Identifier:	36-945
	Revision:	0
Classification: Controlled Disclosure	Page:	48 of 117

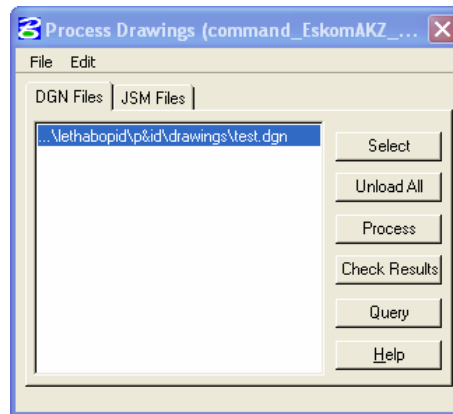

Fig. 32

- The user must select a drawing to process the drawing using the above dialog box by selecting “Process”.
- Only one drawing must be selected for processing.
- Once the drawing has been processed the user must select “Check Results” to verify if any errors were encountered.
- The errors listed in the “Query Results” dialog box must be reviewed and resolved on the PFD or P&ID
- The user must continue reprocessing the drawing and querying the results until no further errors are reported.
- The following items can be regarded as acceptable errors if they cannot be resolve by the user:
 - “Missing To”
 - “Missing From”
 - “Conflicting Flow” if after inspection the flow has been verified as being correct.
- The “Query” button can be used to view the data associated with any selected tagged item.

7.2 Checking of PFD’s and P&ID’s using paper prints

The following auditable procedure must be followed to ensure all PFD’s and P&ID’s are checked prior to being issued.

- 7.2.1 Once the draughtsperson has completed a PFD or P&ID a check print must be issued to the responsible engineer or draughtsperson. The check print must be clearly stamped “CHECK PRINT”.
- 7.2.2 The responsible engineer or draughtsperson must check the PFD or P&ID:
- using the toolboxes as specified in Clause D.7.1
 - against the relevant marked up PFD or P&ID
 - with the codification officer to ensure that all tagged items comply with the site codification system as required.
- 7.2.3 The responsible engineer or draughtsperson must verify that all the items on the PFD or P&ID have been Tagged in accordance with Clause D.6.0.

Work Instruction for Process (P&ID, PFD, PPF and SPFD), Hydraulic and Pneumatic Drawings	Unique Identifier:	36-945
	Revision:	0
Classification: Controlled Disclosure	Page:	49 of 117

- 7.2.4 Once the responsible engineer or draughtsperson has completed checking and verifying the PFD or P&ID the check print must be signed and dated and the full name of the checker must be recorded on the drawing.
- 7.2.5 The PFD or P&ID must then be returned to the responsible draughtsperson. All discrepancies or queries must be clearly marked up utilising the following colour code system and reviewed with the responsible draughtsperson.
- Red corrections
 - Yellow delete
 - Blue comments (will not be draughted)
 - Green correct
- 7.2.6 The draughtsperson will back draught the "CHECK PRINT" of the PFD or P&ID and re-issue the PFD or P&ID to the same responsible engineer or draughtsperson as a revised "CHECK PRINT" for re-checking. Once no more discrepancies are marked up on the "CHECK PRINT" by the responsible engineer or draughtsperson and he/she has signed off the PFD or P&ID the PFD or P&ID is ready for issue to Eskom.
- 7.2.7 Note all superseded paper copies of all PFD's or P&ID's must be clearly stamped "SUPERSEDED" by the responsible draughtsperson as soon as the corrections have been made.
- 7.2.8 All "SUPERSEDED" PFD's or P&ID's must be retained as part of the drawing office records.
- 7.2.9 If required PFD's or P&ID's must be issued to Eskom for "Checking" in accordance with Clause A.19.0.
- 7.2.10 Each PFD or P&ID issued to Eskom for checking must be issued together with a NCR which specifies all outstanding issues relating to the PFD or P&ID that must be resolved by Eskom. NCR's must be created for all PFD's or P&ID's whether or not they have outstanding issues.
- 7.2.11 Each PFD or P&ID issued to Eskom for checking must be clearly stamped "CHECK PRINT".
- 7.2.12 Eskom must appoint a responsible engineer or draughtsperson to check the PFD or P&ID and resolve all the items listed on the NCR.
- 7.2.13 Once the Eskom responsible engineer or draughtsperson has completed checking a PFD or P&ID the check print must be signed and dated and the full name of the checker must be recorded on the PFD or P&ID.
- 7.2.14 The PFD or P&ID must then be returned to the responsible draughtsperson or Contractor. All discrepancies or queries must be clearly marked up utilising the following colour code system and reviewed with the responsible draughtsperson.
- Red corrections
 - Yellow delete
 - Blue comments (will not be draughted)
 - Green correct
- 7.2.15 If required the PFD or P&ID must be issued to the Contractor for updating/back draughting in accordance with Clause A.14.0.
- 7.2.16 Once the checked PFD or P&ID is received from Eskom the responsible draughtsperson will review any non conformances marked up on the PFD or P&ID or recorded on the NCR with Eskom if required and revise the PFD or P&ID accordingly.
- 7.2.17 The PFD or P&ID must then be re-checked in accordance with this procedure.
- 7.2.18 Once all the PFD's or P&ID's non conformances marked up on the PFD or P&ID or recorded on the NCR have been resolved by Eskom the PFD or P&ID will be checked reviewed, authorised and approved in accordance with the applicable workflow stipulated in "ANNEXURE A".

Work Instruction for Process (P&ID, PFD, PPF and SPFD), Hydraulic and Pneumatic Drawings	Unique Identifier:	36-945
	Revision:	0
Classification: Controlled Disclosure	Page:	50 of 117

8. CREATE PROJECT DATABASE (PDB)

8.1 Prior to the PDB being created the following steps must have been completed:

- All items must comply with PlantSpace P&ID settings and symbology as referred to in Clause 7.1.1.
- The PFD or P&ID must be processed with no “Check Results” errors in accordance with Clause 7.1.2.
- The Content of the PFD or P&ID must be verified as being correct in accordance with Clause 7.2.

8.2 To create the PDB the following steps must be followed:

- Immediately after processing the drawing select “ProjDB”, “Synchronizing” from the menu or the icon as indicated below.



Fig. 33

Database Information

This tool can be used to view the PDB information relating to the selected tagged item.

Synchronize Database

This tool must be used to write data to the PDB.

Sync Tags from DB

This tool can be used to update data from the PDB to the PFD or P&ID.

- The “Synchronizing ProjDB” dialog box will open.
- Select “Update Database” and the “Run” button.

8.3 All Tagged items will be written into the PDB.

9. DATABASE VERIFICATION OF PFD's AND P&ID's

Data verification of a PFD or P&ID must be carried out once the PFD or P&ID has been created and checked.

9.1 A report must be created and printed that extracts the Tagged data per PFD or P&ID.

9.2 The report must list the following information per PFD or P&ID:

- 9.2.1 drawing number
- 9.2.2 drawing revision
- 9.2.3 drawing title
- 9.2.4 AKZ/KKS plant code

9.3 Once the draughtsperson has completed printing a report for a PFD or P&ID a check print of the drawing must be issued to the responsible engineer or draughtsperson. The check print must be clearly stamped “CHECK PRINT”.

Work Instruction for Process (P&ID, PFD, PPF and SPFD), Hydraulic and Pneumatic Drawings	Unique Identifier:	36-945
	Revision:	0
Classification: Controlled Disclosure	Page:	51 of 117

- 9.4 The responsible engineer or draughtsperson must check the PFD or P&ID against the relevant report. Verifying that all Tagged items have been captured and reported. This must be carried out by marking off each Tagged Item on the drawing and the report.
- 9.5 The PFD or P&ID must be returned to the responsible draughtsperson. All discrepancies between the report and the "CHECK PRINT" of the drawing must be clearly marked up on the "CHECK PRINT" utilising the following colour code system and reviewed with the responsible draughtsperson.
- Red corrections
 - Yellow delete
 - Blue comments (will not be draughted)
 - Green correct
- 9.6 The draughtsperson will back draught the "CHECK PRINT" of the PFD or P&ID rerun the report and re-issue the PFD or P&ID and updated report to the same responsible engineer or draughtsperson for re-checking.
- 9.7 Once no more discrepancies are found between the "CHECK PRINT" and the report by the responsible engineer or draughtsperson and he/she has signed off the PFD or P&ID the PFD or P&ID is ready for issue to Eskom for data verification.
- 9.8 Note all superseded paper copies of all PFD's or P&ID's must be clearly stamped "SUPERSEDED" by the responsible draughtsperson as soon as the corrections have been made.
- 9.9 If required the PFD or P&ID must be issued to Eskom for Data Verification. in accordance with Clause A.19.0.
- 9.10 Eskom must appoint a responsible engineer or draughtsperson to carry out Data Verification of the PFD or P&ID.
- 9.11 A report must be created and printed that extracts the Tagged data per PFD or P&ID.
- 9.12 The report must list the following information per PFD or P&ID:
- 9.12.1 drawing number
 - 9.12.2 drawing revision
 - 9.12.3 drawing title
 - 9.12.4 AKZ plant code
- 9.13 Once the draughtsperson has completed printing a report for a PFD or P&ID a check print of the drawing must be issued to the responsible engineer or draughtsperson. The check print must be clearly stamped "CHECK PRINT".
- 9.14 The responsible engineer or draughtsperson must check the PFD or P&ID against the relevant report, verifying that all Tagged items have been captured and reported. This must be carried out by marking off each Tagged Item on the PFD or P&ID and the report.
- 9.15 The PFD or P&ID must then be returned to the responsible draughtsperson. All discrepancies between the report and the "CHECK PRINT" of the PFD or P&ID must be clearly marked up on the "CHECK PRINT" utilising the following colour code system.
- Red corrections
 - Yellow delete
 - Blue comments (will not be draughted)
 - Green correct
- 9.16 If required the PFD or P&ID must be issued to the Contractor for updating/back draughting in accordance with Clause A.14.0.

Work Instruction for Process (P&ID, PFD, PPFID and SPFD), Hydraulic and Pneumatic Drawings	Unique Identifier:	36-945
	Revision:	0
Classification: Controlled Disclosure	Page:	52 of 117

- 9.17 The Contractor or draughtsperson will back draught the "CHECK PRINT" of the PFD or P&ID rerun the report and re-issue the PFD or P&ID and updated report to the same responsible engineer or draughtsperson for re-checking.
- 9.18 The PFD or P&ID must then be re-verified.
- 9.19 Once all the Text Tagged non conformances marked up on the PFD or P&ID have been resolved by Eskom the PFD or P&ID will be reviewed, authorised and approved in accordance with the applicable workflow stipulated in Annexure "A" of 36-943.

SECTION C - PFD'S AND P&ID'S IN ACCORDANCE WITH KKS STANDARD

The standard for creating and updating PFD's and P&ID's in accordance with the KKS codification system will be incorporated in a subsequent revision of this standard.

Work Instruction for Process (P&ID, PFD, PPF and SPFD), Hydraulic and Pneumatic Drawings	Unique Identifier:	36-945
	Revision:	0
Classification: Controlled Disclosure	Page:	53 of 117

SECTION D - CUSTOMISED CAD FILES

1. INSTALLATION OF CUSTOMISED CAD FILES FOR ALL DRAWINGS

The Eskom customised general CAD files must be installed prior to commencing with draughting of drawings in accordance with this standard. This is done in accordance with 36-944

2. INSTALLATION OF CUSTOMISED CAD FILES FOR P&ID's AND PFD's

In addition to the files specified in Clause F1.0 the following steps must be followed prior to commencing with draughting of P&ID's and PFD's in accordance with this standard.

- 2.1 The standard configuration files and folders must be copied from the setup disc to the Bentley installation directory as indicated below:

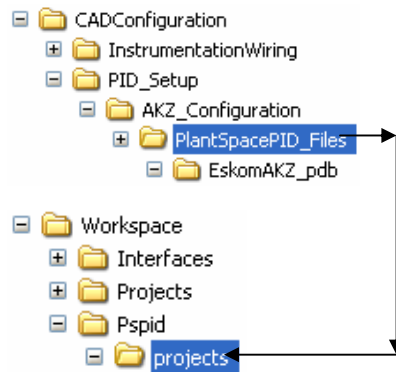

- 2.2 Edit the file "EskomAKZ_pdb.pcf" by changing the following line:
PDB_APPROJDB=To reflect the installation directory of the EskomAKZ_pdb project.

- 2.3 The standard configuration files and folders must be copied from the setup disc to the Bentley installation directory as indicated below:

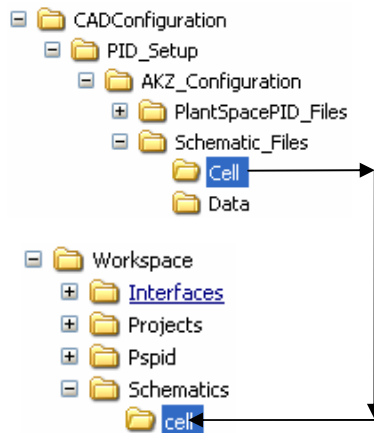

Work Instruction for Process (P&ID, PFD, PPF and SPFD), Hydraulic and Pneumatic Drawings	Unique Identifier:	36-945
	Revision:	0
Classification: Controlled Disclosure	Page:	54 of 117

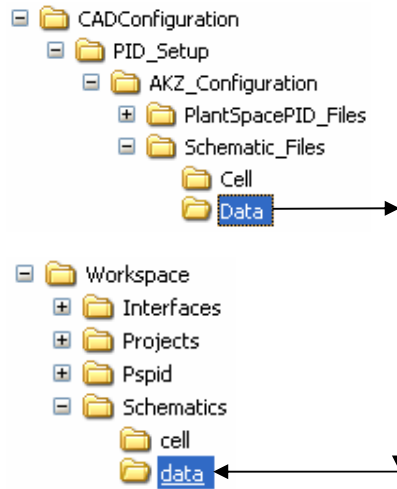

2.4 If applicable a new project must be created using I&W Project Administrator.

- Start I&W's Bentley Project Administrator.
- Select "Add Root" from the "File" menu. The "Browse For Folder" dialog box will open.
- Select "Make New Folder" to create a directory where the New Project Root Directory folder must be installed.
- Select "Project Packager" from the "Tools" menu. The Project Packager dialog box will open.
- Select the "UnPackage Project" radio button followed by the "Next" button.
- Use the "Browse" icon in "Select package zip file" to open the Eskom_PDB.zip in the following folder:

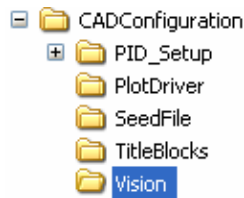

- Use the "Browse" icon in "Select location to unpackage project" to select the directory created followed by the "Next" button.
- Select Access as the "Project Database Type" from the list.
- The project will now unpack to the specified directory.
- Select the "Finish" button to complete the unpacking of the project.
- Select the refresh button to show your unpacked project directories.
- Expand the applicable directory tree until the project EskomAKZ_pdb is available for selection.
- Right click on the project and select the option "Set as Startup Project".

Work Instruction for Process (P&ID, PFD, PPF and SPFD), Hydraulic and Pneumatic Drawings	Unique Identifier:	36-945
	Revision:	0
Classification: Controlled Disclosure	Page:	55 of 117

SECTION E - HYDRAULIC AND PNEUMATIC CIRCUIT DIAGRAMS

1. INSTALLATION OF CUSTOMISED CAD FILES FOR ALL DRAWINGS

The Eskom customised general CAD files must be installed prior to commencing with draughting of drawings in accordance with this standard. This is done in accordance with 36-944

2. INSTALLATION OF CUSTOMISED CAD FILES FOR HYDRAULIC AND PNEUMATIC CIRCUIT DIAGRAMS

- 2.1 In addition to the Eskom customised general CAD files, the necessary cell libraries for Hydraulic and Pneumatic circuit Diagrams must also be installed before continuing with draughting of these drawings.
- 2.2 For Hydraulic and Pneumatic drawings/diagrams, the Eskom Standard Hydraulic/Pneumatic Symbol Cell Library, "Hydraulic.Cel" must be used.. The latest version of this cell library is obtainable from MWP Drawing Office.
- 2.3 Users may not make any changes to the standard cell library. Should additional symbols be required, the MWP Drawing Office should be notified and a formal request registered using the form in Annexure "B" of 36-943 to have the symbols added. Symbols in this cell library are depicted in Annexure B.

3. GENERAL REQUIREMENTS FOR DRAUGHTING OF HYDRAULIC AND PNEUMATIC CIRCUIT DIAGRAMS

- 3.1 Symbols on the circuit diagrams must always be depicted in de-energized state or at rest.
- 3.2 Rotation is to be shown by an arrow symbol on the shaft.
- 3.3 An arrow passing through a hydraulic/pneumatic symbol at 45° will indicate that the flow through the component can be regulated.

Work Instruction for Process (P&ID, PFD, PPF and SPFD), Hydraulic and Pneumatic Drawings	Unique Identifier:	36-945
	Revision:	0
Classification: Controlled Disclosure	Page:	56 of 117

SECTION F - ANNEXURES











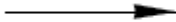





ANNEXURE A – STANDARD CELL LIBRARY FOR PLANT PROCESS DIAGRAMS

ANNEXURE B - STANDARD CELL LIBRARY FOR HYDRAULIC AND PNEUMATIC DIAGRAMS





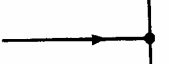
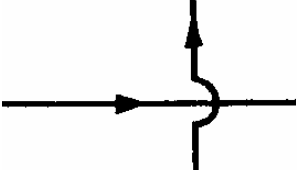







Work Instruction for Process (P&ID, PFD, PPF and SPFD), Hydraulic and Pneumatic Drawings	Unique Identifier:	36-945
	Revision:	0
Classification: Controlled Disclosure	Page:	57 of 117

ANNEXURE A

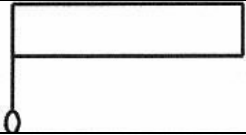
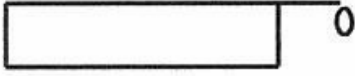
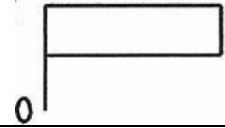
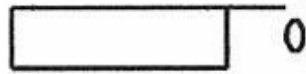







STANDARD CELL LIBRARY FOR PLANT PROCESS DIAGRAMS

CELL NAME	SYMBOL	DESCRIPTION
PIPING: MISCELLANEOUS		
		Process Pipe General (Primary and Secondary) – Can Also be insulated. Select according to requirement and per software configuration.
		Process Pipe Future/Existing (Primary and Secondary). Also used for Jacketed Primary Process Pipes and Process Pipe Ducting. Select according to requirement and per software configuration.
		Main Flow Line (Thick)
		Primary Flow Direction
		Process Line (Thin)
		Secondary Flow Direction
		Trace Heated Line (Primary
3-014		Gas Line
3-015		Compressed Gas Line
3-018		Steam
3-019		Pipelines Bigger Than 100 mm Diameter
3-020		Pipelines up to 100 mm Diameter
		Feed Stock Line (Identify by name)
		Product Line (Identify by name)
		Connecting Line
		Cross-Over Line
3-008		Off-Sheet Connector: Left In a) Flow TO/FROM Another Drawing (Sheet & Grid Indicated) b) Chemical Products (Shown Inside Flag)



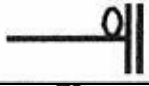

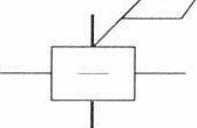
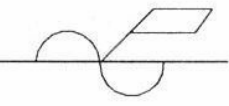
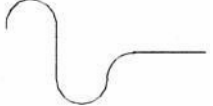

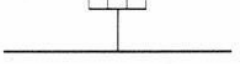
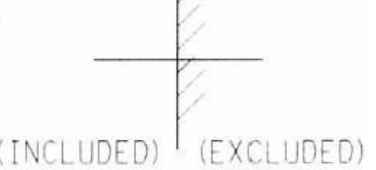
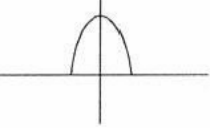
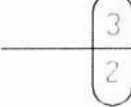

Work Instruction for Process (P&ID, PFD, PPF and SPFD), Hydraulic and Pneumatic Drawings	Unique Identifier:	36-945
	Revision:	0
Classification: Controlled Disclosure	Page:	58 of 117

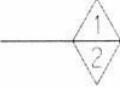
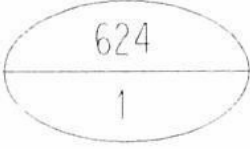
CELL NAME	SYMBOL	DESCRIPTION
		Off-Sheet Connector: Right In
		Off-Sheet Connector: Left Out
		Off-Sheet Connector: Right Out
		Off-Sheet Connector: Left Dual
		Off-Sheet Connector: Right Dual
		Line Break
227		KKS Flag for Lines (Text Height: 3.5 mm) (Text Width: 2.5 mm)
227A		KKS Flag for Lines (Text Height: 3.5 mm) (Text Width: 2.5 mm)
228		Alternative KKS Flag for Lines (Text Height: 3 mm) (Text Width: 2 mm)
228A		Alternative KKS Flag for Lines (Text Height: 3 mm) (Text Width: 2 mm)
		Battery Limit Off-Set
		Battery Limit In-Line
		Spec Break Material: In-Line
		Spec Break Material: Off-Set
		On-Page Line Jumper
		Leader Line













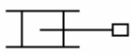

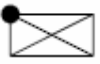

Work Instruction for Process (P&ID, PFD, PPF and SPFD), Hydraulic and Pneumatic Drawings	Unique Identifier:	36-945
	Revision:	0
Classification: Controlled Disclosure	Page:	59 of 117

CELL NAME	SYMBOL	DESCRIPTION
PIPING: MISCELLANEOUS		
		Note Reference
		Gravity Flow Symbol
		Purge Connection
		Sample Connection
		Tie-In Symbol
42		Blank Flange
250		Material Change Indication
3-001		Penetration Containment (With Reference Number)
3-002		Trace Heated Piping <ul style="list-style-type: none"> • STE – Electrical • STV – Steam • SES – Superheated Water
3-003		Loop Seal
3-004		Flexible Hose
3-005		Inspection Manhole Inspection Chamber
3-006		Limit Supply
3-007		Thermal Sleeve
3-009		Quality Classification













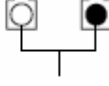

Work Instruction for Process (P&ID, PFD, PPF and SPFD), Hydraulic and Pneumatic Drawings	Unique Identifier:	36-945
	Revision:	0
Classification: Controlled Disclosure	Page:	60 of 117

CELL NAME	SYMBOL	DESCRIPTION
3-010		Safety Classification
3-011		Pipe Number
118		Level Symbol
133		Line Cut Off
148		Machine Symbol Rough
149		Machined Symbol Smooth
150		Polished Finished Symbol
130		Pipe or Shaft Rear View
131		Pipe of Shaft Side View
200	Ø10 NB	10 mm Nominal Bore Pipe
201	Ø15 NB	15 mm Nominal Bore Pipe
202	Ø20 NB	20 mm Nominal Bore Pipe
203	Ø25 NB	25 mm Nominal Bore Pipe
204	Ø32 NB	32 mm Nominal Bore Pipe
205	Ø40 NB	40 mm Nominal Bore Pipe
206	Ø50 NB	50 mm Nominal Bore Pipe
207	Ø65 NB	65 mm Nominal Bore Pipe
208	Ø80 NB	80 mm Nominal Bore Pipe
209	Ø100 NB	100 mm Nominal Bore Pipe
210	Ø125 NB	125 mm Nominal Bore Pipe
211	Ø150 NB	150 mm Nominal Bore Pipe
212	Ø200 NB	200 mm Nominal Bore Pipe
213	Ø250 NB	250 mm Nominal Bore Pipe
214	Ø300 NB	300 mm Nominal Bore Pipe
215	Ø350 NB	350 mm Nominal Bore Pipe
216	Ø400 NB	400 mm Nominal Bore Pipe
217	Ø450 NB	450 mm Nominal Bore Pipe
218	Ø500 NB	500 mm Nominal Bore Pipe
219	Ø600 NB	600 mm Nominal Bore Pipe
220	Ø700 NB	700 mm Nominal Bore Pipe
221	Ø750 NB	750 mm Nominal Bore Pipe
222	Ø800 NB	800 mm Nominal Bore Pipe
223	Ø900 NB	900 mm Nominal Bore Pipe
224	Ø1000 NB	1000 mm Nominal Bore Pipe
225	Ø1200 NB	1200 mm Nominal Bore Pipe
226	Ø1800 NB	1800 mm Nominal Bore Pipe





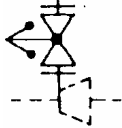





Work Instruction for Process (P&ID, PFD, PPF and SPFD), Hydraulic and Pneumatic Drawings	Unique Identifier:	36-945
	Revision:	0
Classification: Controlled Disclosure	Page:	61 of 117

CELL NAME	SYMBOL	DESCRIPTION
VALVES		
1 1-001		General Valve: Not Specified
11 1-003		Needle Valve
18		Non-Return Valve
		Sliding Gate Valve
15		Angle Valve
14		Angle Check Valve (NRV)
20		Pinch Valve
16		Non-Return Valve Foot-Type
2 1-022		Ball Valve
12		Plug Valve
17		Non-Return Foot-Type Valve With Strainer
3		Butterfly Valve
		Wedge Gate Valve
		Angle Pressure Relief Valve
25 1-046		Angle Relief Valve (Pressure) - Alternative
		Angle Relieve Valve, Vacuum Type
26		Angle Relief Valve (Vacuum) - Alternative
5		Diaphragm Valve, Bonnet Type
6		Diaphragm Valve, Manual Set Type

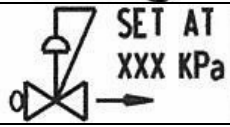



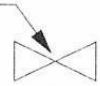
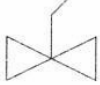
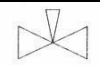

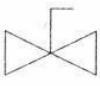
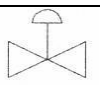
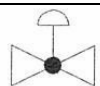
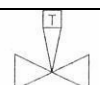
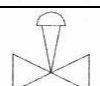



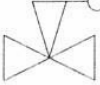







Work Instruction for Process (P&ID, PFD, PPF and SPFD), Hydraulic and Pneumatic Drawings	Unique Identifier:	36-945
	Revision:	0
Classification: Controlled Disclosure	Page:	62 of 117

CELL NAME	SYMBOL	DESCRIPTION
VALVES		
9		Gate Valve
		Slide Valve
		Spherical Valve
34		Air-Release Valve, Double Orifice
38		Dual Change-Over Selector Valve
33		Air Release Valve, Large Orifice
32		Air Release Valve, Small Orifice
10 1-002		Globe Valve
		4-Way Valve
8		4-Way Valve (Arrows Show Failure Position)
		3-Way Valve
		Turbine Inlet Valve
		Automatic Bypass Valve
		Governor Operated Valve
		Automatic Reducing Valve
		Lockshield Valve





Work Instruction for Process (P&ID, PFD, PPF and SPFD), Hydraulic and Pneumatic Drawings	Unique Identifier:	36-945
	Revision:	0
Classification: Controlled Disclosure	Page:	63 of 117

CELL NAME	SYMBOL	DESCRIPTION
		Quick Opening Valve
		Safety Valve
4		Control Valve with Manual Over-ride
7		Float Valve
22		Pressure Reducing Valve
		Volume Control Damper
		Fire Control Damper
1-004		Steam Gland Leak-Off
1-005		Stuffing Box Gland Seal
1-006		Remote Manual Valve
1-007		Manual Control Valve
1-008		Manual Globe Valve
1-009		Lever Gate Valve
1-010		Pneumatic Valve
1-011		Pneumatic Globe Valve
1-012		Piston Control Valve (Hydraulic or Pneumatic)
1-013		Pneumatic Control Valve

Work Instruction for Process (P&ID, PFD, PPF and SPFD), Hydraulic and Pneumatic Drawings	Unique Identifier:	36-945
	Revision:	0
Classification: Controlled Disclosure	Page:	64 of 117

CELL NAME	SYMBOL	DESCRIPTION
1-014		Pneumatic Globe Control Valve
1-015		Float Balance Control Valve
1-016		Inline Relief Valve
1-017		Manual Diaphragm Valve
1-018		Pneumatic Diaphragm Valve
1-019		Single-Coil Solenoid Valve
1-020		Manual Controlled Globe Valve
1-022		Ball Valve
1-023		Manual Ball Valve
1-025		Manual 3-Way Valve
1-026		Manual 3-Way Globe Valve
1-027		3-Way Pneumatic Globe Control Valve
1-028		3-Way Pneumatic Globe Valve
1-029		3-Way Single Coil Solenoid Valve
1-030		3-Way Double Coil Solenoid Valve
1-031		Non-Return Valve
1-033		Manual Butterfly Valve
1-034		Pneumatic Butterfly Valve
1-035		Air Assisted Non-Return Valve

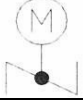
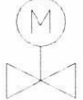
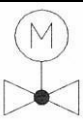
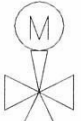
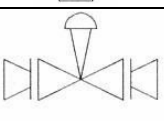
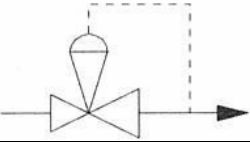
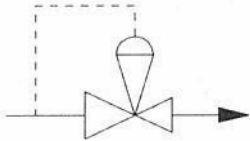
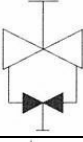
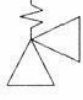

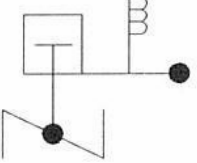
Work Instruction for Process (P&ID, PFD, PPF and SPFD), Hydraulic and Pneumatic Drawings	Unique Identifier:	36-945
	Revision:	0
	Page:	65 of 117

CELL NAME	SYMBOL	DESCRIPTION
1-036		3-Way Ball Valve
1-037		Hydraulic or Piston Non-Return Control Valve
1-038		Motorised Butterfly Valve
1-039		Motorised Valve
1-040		Motorised Globe Valve
1-041		Motorised 3-Way Control Valve
1-042		Pneumatic Control Valve Reduced Closed in Normal Operation
1-043		Pressure Reducing Valve
1-044		Back Pressure Control Valve
1-045		Manual Bypass Valve (Closed in Normal Operation)
1-046		Relief Valve
1-047		3-Way Valve
1-048		Flanged Valve
1-050		Magnetic Clutch Energised Remotely, then Motorised

Work Instruction for Process (P&ID, PFD, PPF and SPFD), Hydraulic and Pneumatic Drawings	Unique Identifier:	36-945
	Revision:	0
Classification: Controlled Disclosure	Page:	66 of 117

CELL NAME	SYMBOL	DESCRIPTION
1-051		Magnetic Clutch Energised Remotely, then Manually Operated
1-052		Vacuum Tight Valve, Normally OPEN (N/O)
1-053		Vacuum Tight Valve, Normally CLOSED (N/C)
1-054		Fire Hydrant
1-055		Vacuum Breaker
1-056		Motorised or Manual Gate Valve
DAMPERS		
7-008		Damper (General)
7-009		Low Leakage Damper
7-010		Fire Damper
7-011		Control Damper
7-012		Diverting Damper
7-013		Guillotine Damper

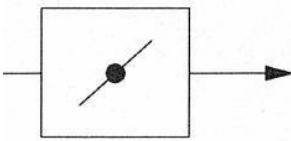
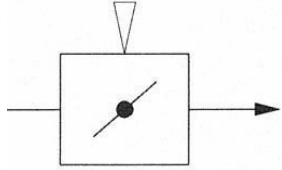
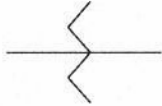
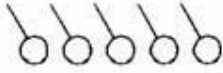











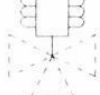

Work Instruction for Process (P&ID, PFD, PPF and SPFD), Hydraulic and Pneumatic Drawings	Unique Identifier:	36-945
	Revision:	0
Classification: Controlled Disclosure	Page:	67 of 117

CELL NAME	SYMBOL	DESCRIPTION
7-014		Smoke Vent
7-015		Control Damper
7-016		Balancing Damper
7-017		Over-Pressure Damper
7-018		Back-Draught Damper





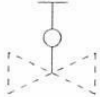
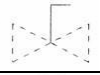













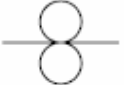

Work Instruction for Process (P&ID, PFD, PPF and SPFD), Hydraulic and Pneumatic Drawings	Unique Identifier:	36-945
	Revision:	0
Classification: Controlled Disclosure	Page:	68 of 117

CELL NAME	SYMBOL	DESCRIPTION
HAND VALVE OPERATORS		
		Hand Wheel
		Hand Wheel with Gearbox
		Lever
		Weight Assisted Operator
		Chain Wheel
		Indicate Fail-Close Position
		Piston Operator, Normal
		Piston Operator, Manual
		Diaphragm Operator, Fail Open
		Float Operator
		Electro-Hydraulic Operator
		Mechanical Fusible Link, Flameback
		Pressure Regulator, Self-Contained
		Power Operated, Unspecified
		Solenoid Operator
		Pressure Regulator, External Tap
		Diaphragm Operator, Fail Closed
		Spring Operator
		Pressure Relief or Safety



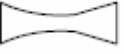





Work Instruction for Process (P&ID, PFD, PPF and SPFD), Hydraulic and Pneumatic Drawings	Unique Identifier:	36-945
	Revision:	0
Classification: Controlled Disclosure	Page:	69 of 117

CELL NAME	SYMBOL	DESCRIPTION
VALVE OPERATORS		
		Manual
		Air Operated
		Piston
		Motorised
		Single Solenoid
		Double Solenoid
		Relief/Vacuum Breaker
		Needle
		Control
		Remote Manual
		Gland Seal Supply
		Gland Leak-Off
		Float Balance Control
		Vacuum Tight
		Lever
		Motorised or Manual

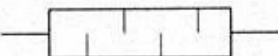
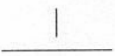
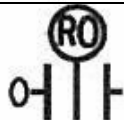
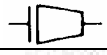

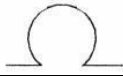
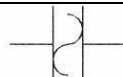
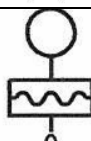
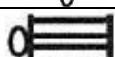



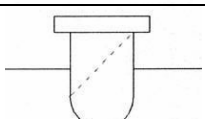
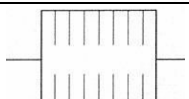

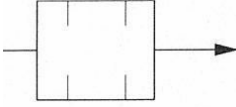
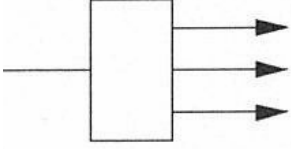
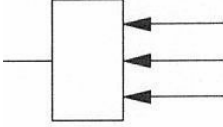
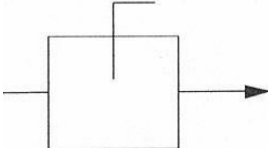
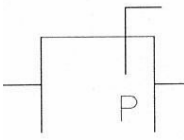

Work Instruction for Process (P&ID, PFD, PPF and SPFD), Hydraulic and Pneumatic Drawings	Unique Identifier:	36-945
	Revision:	0
Classification: Controlled Disclosure	Page:	70 of 117

CELL NAME	SYMBOL	DESCRIPTION
CONTROL VALVES		
		Pneumatic Signal
		Capillary Tube
		Instrument Supply or Connection to Process
		Electro-Magnetic, Sonic, Optical or Nuclear Signal
		Electric Signal
		Software or Data Link
		Hydraulic Signal
		Mechanical Line
		Instrument Line Flow Arrow
176		Unspecified Flow Element
174		Turbine Flow Element
170		Annubar Flow Element
		Ultrasonic Flow Element
171		Magnetic Flow Element
177		V-Notch Weir Flow Element
		Orifice Flow Element
		Density Recorder
173		Pressure Recovery Tube
60		Sight Glass
172		Orifice Plate (Meter)
175		Ultrasonic Flow Element
73		Spectacle Plate



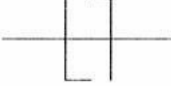





Work Instruction for Process (P&ID, PFD, PPF and SPFD), Hydraulic and Pneumatic Drawings	Unique Identifier:	36-945
	Revision:	0
	Page:	71 of 117
Classification: Controlled Disclosure		

CELL NAME	SYMBOL	DESCRIPTION
PIPE FITTINGS, REDUCERS, FLANGES AND COUPLINGS		
245 9-001		Concentric Reducer Reducer Restrictor
246 9-011		Eccentric Reducer
4-014 9-003		Orifice Flange Flow Restricting Orifice
9-004		Multi-Stage Flow Restricting Orifice
9-002		Flow Measuring Orifice
54		Restriction Orifice
		Reducing Flange
44		Compensator Bellows
4-001		Expansion Loop
4-004		Rupture Disk
45		Chemical Seal
48		Flanged Dismantling Joint
49		Flexible Hose Connection
65 7-001		Vent or Filter
47 7-004		Filter In-line Filter
7-002		Liquid Filter
7-003		Air Filter PFI = Pre-Filter FIA = Absolute Filter PIA = Iodine Filter

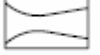
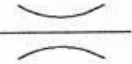
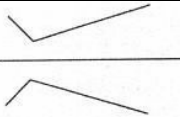
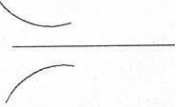

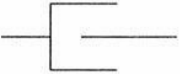
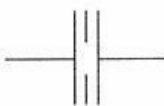

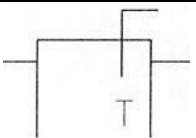
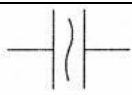
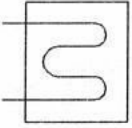

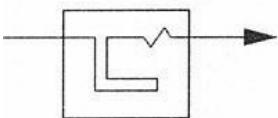



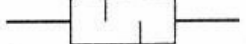

Work Instruction for Process (P&ID, PFD, PPF and SPFD), Hydraulic and Pneumatic Drawings	Unique Identifier:	36-945
	Revision:	0
	Page:	72 of 117
Classification: Controlled Disclosure		

CELL NAME	SYMBOL	DESCRIPTION
7-019		Sound Attenuator
7-020		Air Exhaust
7-021		Air Intake
7-022		Closing Device
7-023		Door
52		Insulated Block Joint
		Spacer
248		Overflow Tundish
		Restriction Orifice
46		Coupling: No Specification
4-003		Quick Disconnect Coupling
9-005		Bauhmann Coupling
9-006		Staubli
9-007		Staubli with Non-Return

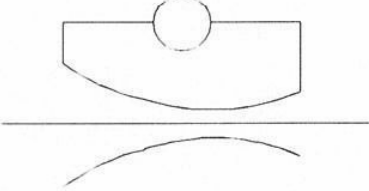
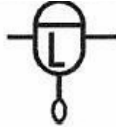
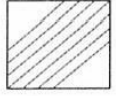

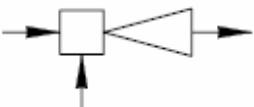
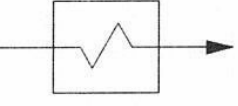









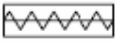





Work Instruction for Process (P&ID, PFD, PPF and SPFD), Hydraulic and Pneumatic Drawings	Unique Identifier:	36-945
	Revision:	0
Classification: Controlled Disclosure	Page:	73 of 117

CELL NAME	SYMBOL	DESCRIPTION
		Blank
247		Bell-Mouth Outlet
72		Venturi Flow Nozzle
9-009		Venturi
9-010		Tube Venturi
9-008		Nozzle Flow Restriction
		Rubber Joint
4-002		Sliding Joint
4-015		Orifice
4-016		Expansion Joint
7-024		Sliding "T"-Plate
7-025		Membrane
7-026		Chiller (Water Cooling Coil)
7-027		Steam Trap
7-028		Drain Cooler Reheater, With Condensate

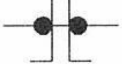











Work Instruction for Process (P&ID, PFD, PPF and SPFD), Hydraulic and Pneumatic Drawings	Unique Identifier:	36-945
	Revision:	0
Classification: Controlled Disclosure	Page:	74 of 117

CELL NAME	SYMBOL	DESCRIPTION
4-017		Flanged Expansion Joint
4-018		Bellows
4-019		Compensating Bellows
4-020		Socket (PVC Only)
4-021 7-030		Sand Trap
4-022		Quick Disconnect Coupling (Small – max diameter)
5-002		Flow Venturi
69		Mist Lubricator
7-029		Humidifier
		Flexible Hose Connection
68		Silencer
103		Ejector/Injector
7-031		Reheater Surface De-Superheater Steam Transformer
53		Pig Hatch
70		Pyrometer
61		Sliding Expansion Joint

Work Instruction for Process (P&ID, PFD, PPF and SPFD), Hydraulic and Pneumatic Drawings	Unique Identifier:	36-945
	Revision:	0
Classification: Controlled Disclosure	Page:	75 of 117

CELL NAME	SYMBOL	DESCRIPTION
55		Rubber Expansion Joint
51		Floor Washing Hose Reel
50		Flexible Hose/Tubing
42		Blank Flange
4-005		Spectacle Flange
4-006		Blind Flange (Bolted)
4-008		Flanged Connection (Bolted)
4-009		Blind Flange (Welded)
4-010		Flanged Connection (Welded)
4-011		Screwed Cap
4-012		Welded Cap
4-013		Screwed Union
4-014		Welded Coupling
		Open Figure-8 Blind
		Closed Figure-8 Blind
41		Man-Hole Access Way
71		Vent
48		Flanged Dismantling Joint
249		Drain Point



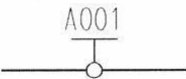
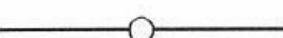



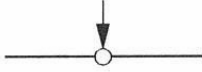
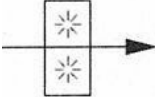
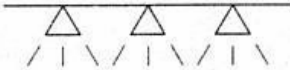
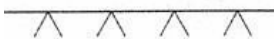
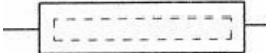
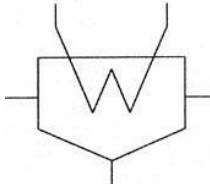
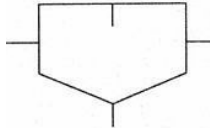
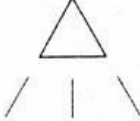



Work Instruction for Process (P&ID, PFD, PPF and SPFD), Hydraulic and Pneumatic Drawings	Unique Identifier:	36-945
	Revision:	0
	Page:	76 of 117
Classification: Controlled Disclosure		

CELL NAME	SYMBOL	DESCRIPTION
57		Sampling Point
62		Static Mixer
64		Sluice Gate
67		Trap (Air Lines)
2-001		Drain
2-002		Vent
2-003		Leak-Off Control
2-004		Sample Connection Sample Point
2-005		Pot Drain
2-006		Funnel
2-008		Capped Vent
2-009		Vent Open to Atmosphere
31-001		Manhole (001 Serial Number)
31-002		Manhole – A: Curb Drain (Sidewalk) B: Manhole with Grate Cover R: Manhole





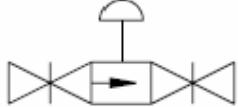
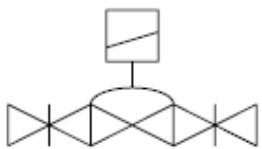
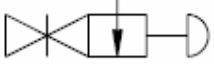







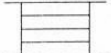
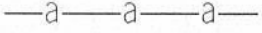
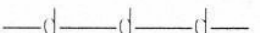
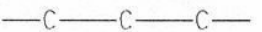
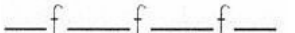

Work Instruction for Process (P&ID, PFD, PPF and SPFD), Hydraulic and Pneumatic Drawings	Unique Identifier:	36-945
	Revision:	0
Classification: Controlled Disclosure	Page:	77 of 117

CELL NAME	SYMBOL	DESCRIPTION
31-003		Manhole for Downcomer
8-001		Water Spray
8-002		Mixer Spray Nozzles
8-003		Spray Nozzles
8-004		Silencer
8-005		Separator (Sodium Vapour)
8-006		Separator (Droplet)
8-007		Eye-Wash Basin



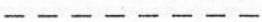

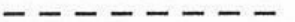

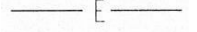
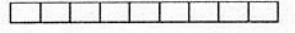









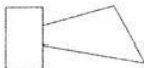

Work Instruction for Process (P&ID, PFD, PPF and SPFD), Hydraulic and Pneumatic Drawings	Unique Identifier:	36-945
	Revision:	0
Classification: Controlled Disclosure	Page:	78 of 117

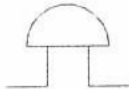
CELL NAME	SYMBOL	DESCRIPTION
FIRE CONTROL (DETECTION & PROTECTION) SYSTEMS		
190		Alarm Valve with Isolator (Wet)
199	FA 	Foam Air Inductor
198	FC 	Foam Concentrate Inductor
188		Frangible Bulb Heat Detector
195		Hydrant
194		Fire Hose Reel
189		Multi-Jet Controller
197		Foam Pourer
196		Water Turbine Alarm Gong
191		Deluge Valve with Isolators (Dry) Air/Water Operated
192		Deluge Valve with Isolators (Dry) Solenoid Operated
193		Differential Air Valve with Isolators (Dry)
186		High Velocity Spray Nozzle
187		Medium Velocity Spray Nozzle











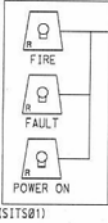



Work Instruction for Process (P&ID, PFD, PPF and SPFD), Hydraulic and Pneumatic Drawings	Unique Identifier:	36-945
	Revision:	0
Classification: Controlled Disclosure	Page:	79 of 117

CELL NAME	SYMBOL	DESCRIPTION
FIRE CONTROL (DETECTION & PROTECTION) SYSTEMS		
185		Sprinkler Head with Glass Bulb
A14		Fire Damper
A15		Line Isolator
A22		Automatic Door Closer (Complete)
A23		Door "Hold Open" Device
A24		Cat Ladder
A25		Buzzer
A26		Fire Hose Reel
FIRE CONTROL (DETECTION & PROTECTION) SYSTEMS – CABLING TYPES, CABLING, TRUNKING, DUCTING AND CABLE TRAYS		
K01		Analogue
K01		Digital
K01		Co-Axial
K01		Fibre-Optic
L01		Loose Fire Retardant Cabling
L02		Armoured Fire Detection Cabling
L03		NLW 25mm Diameter Galvanised Conduit
L04		Existing 25mm Diameter Galvanised Conduit Used
L05		Existing 25mm Diameter Galvanised Conduit for Removal
L06		Trunking (As Specified on Particular Drawings)
L07		Existing MICC to be Re-Used
L08		EGA Ducting (As Specified on Particular Drawings)
L09		Cable Trays

















Work Instruction for Process (P&ID, PFD, PPF and SPFD), Hydraulic and Pneumatic Drawings	Unique Identifier:	36-945
	Revision:	0
Classification: Controlled Disclosure	Page:	80 of 117

CELL NAME	SYMBOL	DESCRIPTION
FIRE CONTROL (DETECTION & PROTECTION) SYSTEMS		
A01		Master Fire Detection Control Panel
A02		Fire Detection Control Panel
A03		Mimic Indication Panel
A04		Remote Indicator
A05		Connecting Box
A06		Break-Glass Unit (100x100 mm Outlet Box)
A07		Break-Glass Release
A08		Horn Siren
A09		Audio Visual Alarm
A10		Speaker
A11		Flashing Beacon
A12		Bell
A13		Emergency Fire Telephone
		Flow Switch
		Pressure Switch
		Input/Output Interface Unit
		Explosive Interface/Barrier
		Extinguishing System Status Panel and Isolation Switch
		"Extinguishant Released" Indicator











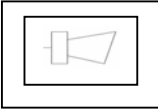

Work Instruction for Process (P&ID, PFD, PPF and SPFD), Hydraulic and Pneumatic Drawings	Unique Identifier:	36-945
	Revision:	0
	Page:	81 of 117
Classification: Controlled Disclosure		

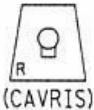
CELL NAME	SYMBOL	DESCRIPTION
FIRE CONTROL (DETECTION & PROTECTION) SYSTEMS		
1		Solenoid Operated Deluge Valve with Isolators
2		Status Indicator 3-State Hard Wired
3		Conventional Detector, Gas Flammable
4		Addressable Detector, Gas Flammable
5		Conventional Detector, Gas Toxic
6		Addressable Detector, Gas Toxic
7		Conventional Instrument Pressure Switch (Low)
8		Conventional Instrument Pressure Switch (Low-Low)
9		Conventional Instrument Pressure Switch (High)
10		Conventional Instrument Water Flow Switch
11		Conventional Callpoint Manual Alarm (Standard)
12		Addressable Callpoint Manual Alarm (Standard)
13		Conventional Callpoint Manual Alarm (Weather Proof)
14		Addressable Callpoint Manual Alarm (Weather Proof)
15		Conventional Detector Flame Combined









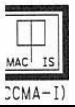

Work Instruction for Process (P&ID, PFD, PPF and SPFD), Hydraulic and Pneumatic Drawings	Unique Identifier:	36-945
	Revision:	0
Classification: Controlled Disclosure	Page:	82 of 117

CELL NAME	SYMBOL	DESCRIPTION
FIRE CONTROL (DETECTION & PROTECTION) SYSTEMS		
16		Addressable Detector Flame Combined
17		Conventional Detector Flame Infra-Red
18		Addressable Detector Flame Infra-Red
19		Conventional Detector Flame Ultra Violet
20		Addressable Detector Flame Ultra Violet
21		Conventional Detector Heat Fixed Temperature (Standard)
22		Addressable Detector Heat Fixed Temperature (Standard)
23		Conventional Detector Heat Rate of Rise (Standard)
24		Addressable Detector Heat Rate of Rise (Standard)
25		Conventional Detector Smoke Ionisation (Standard)
26		Addressable Detector Smoke Ionisation (Standard)
27		Conventional Detector Smoke Optical (Standard)
28		Addressable Detector Smoke Optical (Standard)
29		Conventional Detector Smoke Optical Beam Receiver
30		Addressable Detector Smoke Optical Beam Transmitter
31		Conventional Detector Smoke Optical Beam Unitised
32		Addressable Detector Smoke Optical Beam Unitised

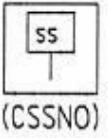
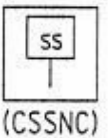



















Work Instruction for Process (P&ID, PFD, PPF and SPFD), Hydraulic and Pneumatic Drawings	Unique Identifier:	36-945
	Revision:	0
	Page:	83 of 117
Classification: Controlled Disclosure		

CELL NAME	SYMBOL	DESCRIPTION
FIRE CONTROL (DETECTION & PROTECTION) SYSTEMS		
33		Non-Specific Box Zener Barrier (Standard)
34		Addressable Zone Isolator (Standard)
35		Conventional Alarm Audible Siren (Standard)
36		Conventional Alarm Audible Siren (Weather Proof)
37		Conventional Alarm Visual Beacon, Xenon (Standard)
38		Conventional Alarm Visual Beacon, Xenon (Weather Proof)
39		Conventional Alarm Remote Indicator (Standard)
40		Conventional Alarm Remote Indicator (Weather Proof)
41		Conventional Alarm Audible Bell (Standard)
42		Conventional Alarm Audible Bell (Weather Proof)
43		Conventional Callpoint Extinguishant Release (Standard)
44		Conventional Callpoint Extinguishant Release (Weather Proof)
45		Conventional Callpoint Water Release (Standard)
46		Conventional Callpoint Water Release (Weather Proof)
47		Addressable Interface Unit, Input (Standard)















Work Instruction for Process (P&ID, PFD, PPF and SPFD), Hydraulic and Pneumatic Drawings	Unique Identifier:	36-945
	Revision:	0
Classification: Controlled Disclosure	Page:	84 of 117

CELL NAME	SYMBOL	DESCRIPTION
FIRE CONTROL (DETECTION & PROTECTION) SYSTEMS		
48		Addressable Interface Unit, Input (Weather Proof)
49		Addressable Interface Unit, Output (Standard)
50		Addressable Interface Unit, Output (Weather Proof)
51		Conventional Callpoint Manual Alarm, Intrinsically Safe
52		Conventional Detector Heat Fixed Temperature, Intrinsically Safe
53		Conventional Supervisory Switch, Normally Open
54		Conventional Supervisory Switch, Normally Closed
55		Universal Node
56		Equipment Boundary
57		Area Boundary
58		Local Repeater Panel
59		Global Repeater Panel
60		Area Alarm Panel



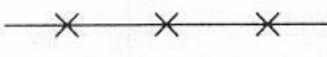

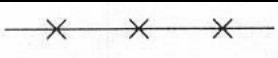
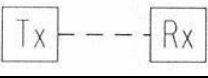



Work Instruction for Process (P&ID, PFD, PPF and SPFD), Hydraulic and Pneumatic Drawings	Unique Identifier:	36-945
	Revision:	0
Classification: Controlled Disclosure	Page:	85 of 117

CELL NAME	SYMBOL	DESCRIPTION
FIRE CONTROL (DETECTION & PROTECTION) SYSTEMS – NORMAL DETECTORS		
B01		Optical
B02		Ionisation
B03		Flame
B04		Heat Rate of Rise
B05		Heat Fixed Temperature Point
B06		Combination Fixed Temperature & Heat Rate of Rise
B07		Water
FIRE CONTROL (DETECTION & PROTECTION) SYSTEMS – CEILING DETECTORS		
C01		Optical
C02		Ionisation
C03		Flame
C04		Heat Rate Of Rise
C05		Heat Fixed Temperature Point
C06		Combination Fixed Temperature & Heat Rate of Rise
C07		Water
FIRE CONTROL (DETECTION & PROTECTION) SYSTEMS – FLOOR DETECTORS		
D01		Optical
D02		Ionisation
D03		Flame
D04		Heat Rate Of Rise
D05		Heat Fixed Temperature Point
D06		Combination Fixed Temperature & Heat Rate of Rise
D07		Water

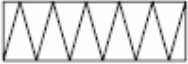
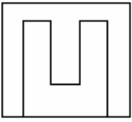

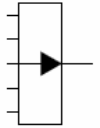
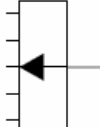

Work Instruction for Process (P&ID, PFD, PPF and SPFD), Hydraulic and Pneumatic Drawings	Unique Identifier:	36-945
	Revision:	0
Classification: Controlled Disclosure	Page:	86 of 117

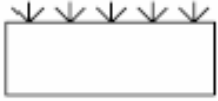
CELL NAME	SYMBOL	DESCRIPTION
FIRE CONTROL (DETECTION & PROTECTION) SYSTEMS – INTRINSICALLY SAFE DETECTORS		
E01		Optical
E02		Ionisation
E03		Flame
E04		Heat Rate Of Rise
E05		Heat Fixed Temperature Point
E06		Combination Fixed Temperature & Heat Rate of Rise
FIRE CONTROL (DETECTION & PROTECTION) SYSTEMS – SMOKE CATCHING PLATE DETECTORS		
F01		Optical
F02		Ionisation
FIRE CONTROL (DETECTION & PROTECTION) SYSTEMS – DUCT PROBE DETECTORS		
G01		Optical
G02		Ionisation
FIRE CONTROL (DETECTION & PROTECTION) SYSTEMS – HIGH SENSITIVITY AIR SAMPLING UNITS		
H01		Air Sampling Unit with Laser Sensing Technology
H02		PVC Air Sampling Tubing (Diameter of Tube and Holes to be Custom Indicated)
FIRE CONTROL (DETECTION & PROTECTION) SYSTEMS – AIR SAMPLING DEVICES (INCLUDING POINT SMOKE DETECTORS)		
I01		Air Sampling Device with Smoke Point Detectors
I02		PVC Air Sampling Tubing (Diameter of Tube and Holes to be Custom Indicated)
FIRE CONTROL (DETECTION & PROTECTION) SYSTEMS – LINEAR BEAM DETECTORS		
J01		Beam Detector Transmitter and Receiver
J02		Beam Reflector

Work Instruction for Process (P&ID, PFD, PPF and SPFD), Hydraulic and Pneumatic Drawings	Unique Identifier:	36-945
	Revision:	0
	Page:	87 of 117
Classification: Controlled Disclosure		





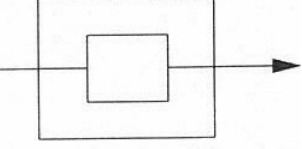









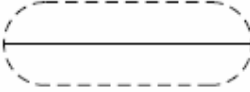

CELL NAME	SYMBOL	DESCRIPTION
HVAC SYSTEMS		
841		Pre-Air Filter PFI PRE
842		Air Filter FAI Absolute
843		Air Filter PAI Iodine
832		Filter Bank
844		Electrical Air Heater
845		Steam Air Heater
853		Heater Bank
852		Cooling Coil
848		Cooler
846 7-021		Air Intake
849 7-020		Air Exhaust
847 7-019		Sound Attenuator
851		Humidifier

Work Instruction for Process (P&ID, PFD, PPF and SPFD), Hydraulic and Pneumatic Drawings	Unique Identifier:	36-945
	Revision:	0
Classification: Controlled Disclosure	Page:	88 of 117



CELL NAME	SYMBOL	DESCRIPTION
833		Axial Fan
834		Extract Arrow
850		Fire Control Damper
854		Reheater
910-005		Cooling Tower Ventilation

CELL	SYMBOL	DESCRIPTION
-------------	---------------	--------------------



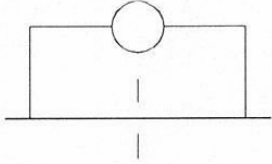

Work Instruction for Process (P&ID, PFD, PPF and SPFD), Hydraulic and Pneumatic Drawings	Unique Identifier:	36-945
	Revision:	0
Classification: Controlled Disclosure	Page:	89 of 117

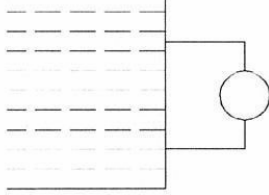
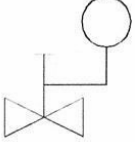
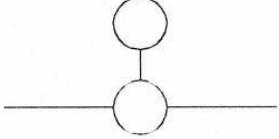
NAME		
VACUUM SYSTEM INSTRUMENTATION		
		Vacuum Lines, Isolation Valve with Hose Connection
		Vacuum Bulk Transport Connection
		Vacuum Standard Cleaning Connection
		Local Mounted Instrument
		Mounted on Instrument Auxiliary Panel
		Mounted on Instrument Panel in Control Room
		Mounted on Local Instrument Panel or Control Box
		VDU Display, Computer
		Future Instrument
		Electro-Pneumatic Converter
		Electrical interface
		Logic Binary Control
		Programmable Logic Controller (PLC)
5-004		Sensor (S = Switch)
5-005		Analogue Sensor Local Indicator (I = Indicator)
5-006		Analogue Sensor Transmitter (M = Transmitter)

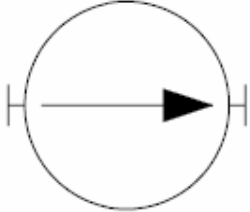
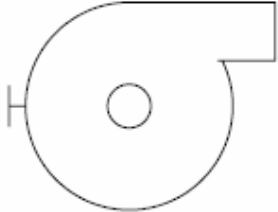

Work Instruction for Process (P&ID, PFD, PPF and SPFD), Hydraulic and Pneumatic Drawings	Unique Identifier:	36-945
	Revision:	0
Classification: Controlled Disclosure	Page:	90 of 117

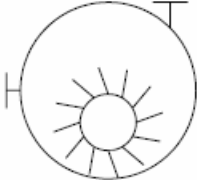
CELL NAME	SYMBOL	DESCRIPTION
5-007		Differential Pressure
5-008		Flow Meter
5-010		Ejector Injector
5-011		Level Meter
5-012		Position Detector/Limit Switch
5-013		In-Line Detector

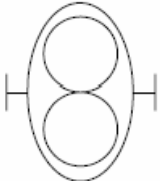

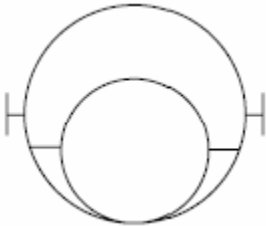
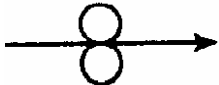
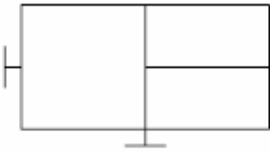
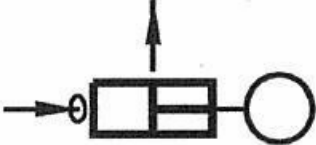
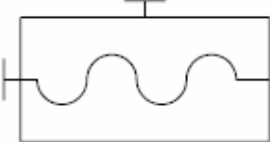
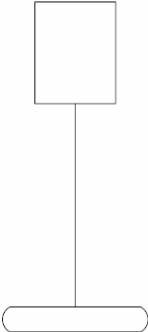

Work Instruction for Process (P&ID, PFD, PPF and SPFD), Hydraulic and Pneumatic Drawings	Unique Identifier:	36-945
	Revision:	0
Classification: Controlled Disclosure	Page:	91 of 117

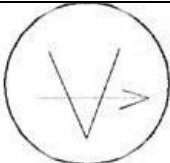
CELL NAME	SYMBOL	DESCRIPTION
PUMPS		
		Pump, Basic: Unspecified
		Centrifugal Pump
		Centrifugal Pump (Alternative)
		Reciprocating Pump
		Vacuum Pump
		Diaphragm Pump
102		Diaphragm Pump (Metering)
97		Gear Pump



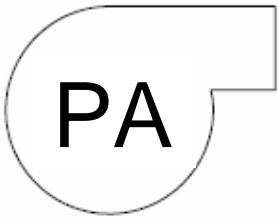

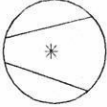
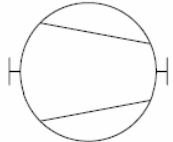
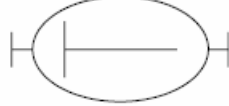
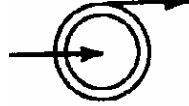
Work Instruction for Process (P&ID, PFD, PPF and SPFD), Hydraulic and Pneumatic Drawings	Unique Identifier:	36-945
	Revision:	0
Classification: Controlled Disclosure	Page:	92 of 117

CELL NAME	SYMBOL	DESCRIPTION
PUMPS		
98		Rotary Pump Liquid Ring Compressor
		Rotary Pump (Alternative)
		Piston Pump
101		Piston Pump (Metering)
100		Progressive Cavity Pump
		Vertical Spindle Pump
6-008		Vacuum Pump Ejector
6-009		Pump (Centrifugal)
6-010		Pump (Positive Displacement)



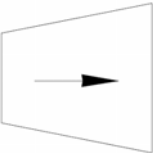

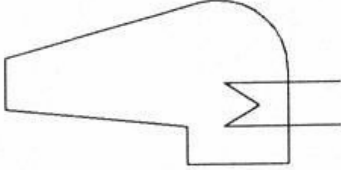
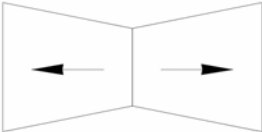
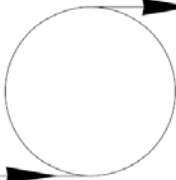



Work Instruction for Process (P&ID, PFD, PPF and SPFD), Hydraulic and Pneumatic Drawings	Unique Identifier:	36-945
	Revision:	0
Classification: Controlled Disclosure	Page:	93 of 117

CELL NAME	SYMBOL	DESCRIPTION
FANS, BLOWERS AND COMPRESSORS		
268		Centrifugal Fan
269		Primary Air Fan
271		Forced Draught Fan
270		Induced Draught Fan
6-011		Fan VC – Centrifugal VH – Helical VHC Helico Centrifugal
92 6-012		Compressor CC – Centrifugal CV - Volumetric
99		Roots Blower
		Centrifugal Fan Centrifugal Blower
285		Fan with Suction Vanes
277		Centrifuge

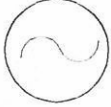

Work Instruction for Process (P&ID, PFD, PPF and SPFD), Hydraulic and Pneumatic Drawings	Unique Identifier:	36-945
	Revision:	0
Classification: Controlled Disclosure	Page:	94 of 117

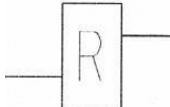
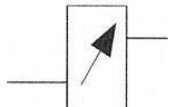
CELL NAME	SYMBOL	DESCRIPTION
TURBINES		
260		Single Stream Gas-Water Turbine
		Turbine, General
910-006		Steam Condensing Turbine
261		Double Flow Steam/Gas/Water Turbine
262		Pump/Turbine
		Generator

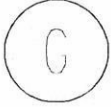

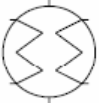

Work Instruction for Process (P&ID, PFD, PPF and SPFD), Hydraulic and Pneumatic Drawings	Unique Identifier:	36-945
	Revision:	0
Classification: Controlled Disclosure	Page:	95 of 117

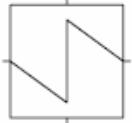
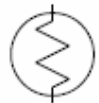
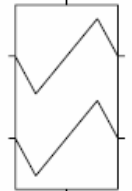
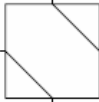
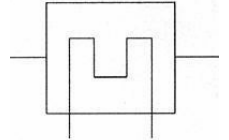
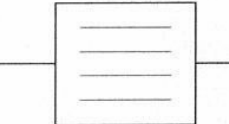
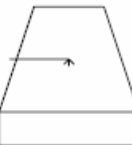
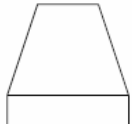
CELL NAME	SYMBOL	DESCRIPTION
DRIVERS		
95		Electric Driver
		Air Driver
94		Diesel Driver
96		Petrol Driver
6-011		Alternator
6-002		Gear Speed Multiplier
6-003		Gear Speed Reducer
6-004		Gear Speed Multiplier/Reducer with Variable Speed
6-005		Motor Electric (DC)
6-006		Motor Electric (AC)
6-007		Electric Generator

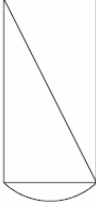

Work Instruction for Process (P&ID, PFD, PPF and SPFD), Hydraulic and Pneumatic Drawings	Unique Identifier:	36-945
	Revision:	0
Classification: Controlled Disclosure	Page:	96 of 117

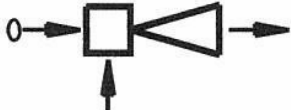
CELL NAME	SYMBOL	DESCRIPTION
HEAT EXCHANGERS		
264		Surface Condenser, Divided on Water Side
256		Superheater Reheater Economisers
275		Feed Water Heater
265		Feed Water Heater De-Superheater Attemporater Water Cooler
263		Surface Condenser Unit Sample Cooler
288		Main Air Heaters
266		Main Pre-Heaters
7-005		Electrical Air Heater
7-007		Cooler
276		Wet Cooling Tower
		Dry Cooling Tower

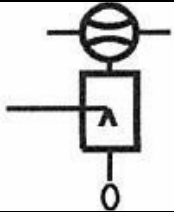
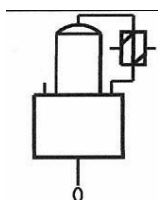
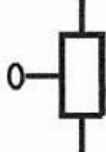
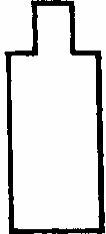

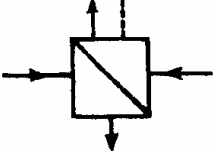
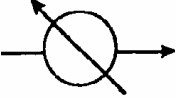
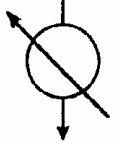
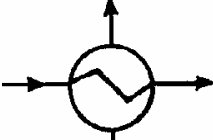

Work Instruction for Process (P&ID, PFD, PPF and SPFD), Hydraulic and Pneumatic Drawings	Unique Identifier:	36-945
	Revision:	0
Classification: Controlled Disclosure	Page:	97 of 117

CELL NAME	SYMBOL	DESCRIPTION
350		Dry Cooling Tower with Forced Draught Fan
274		Evaporator
279 7-006		General Heat Exchanger
255		Boiler
103		Ejector/Injector
273		De-Superheater or Attemporator (Spray Type)
257		De-Aerator
258		De-Aerator with Storage Tank and Vent Condenser
267		Flash Box
		Vertical Boiler

Work Instruction for Process (P&ID, PFD, PPF and SPFD), Hydraulic and Pneumatic Drawings	Unique Identifier:	36-945
	Revision:	0
Classification: Controlled Disclosure	Page:	98 of 117

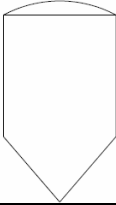



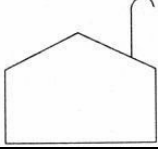
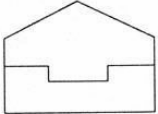
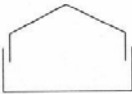
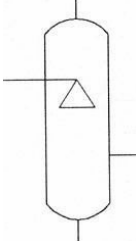
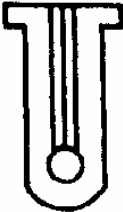
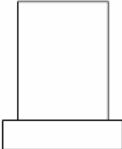

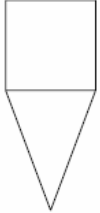
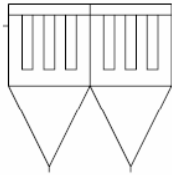
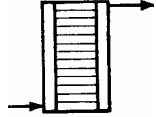
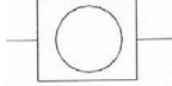
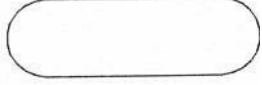
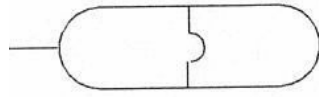
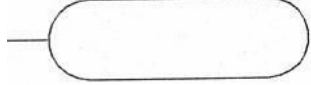
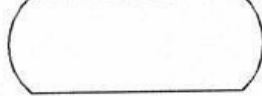
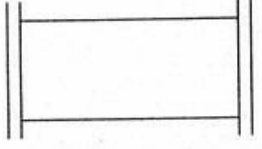
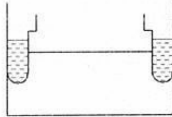
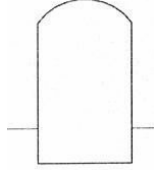



CELL NAME	SYMBOL	DESCRIPTION
		Superheater or Reheater
		Water Cooled Exchanger
		Water Cooled Condenser
		Shell & Tube Exchanger
		Cooling Tower
56		Sample Cooler

Work Instruction for Process (P&ID, PFD, PPF and SPFD), Hydraulic and Pneumatic Drawings	Unique Identifier:	36-945
	Revision:	0
Classification: Controlled Disclosure	Page:	99 of 117

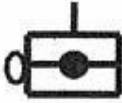
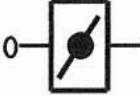

CELL NAME	SYMBOL	DESCRIPTION
VESSELS AND TANKS		
351		Vertical Storage Tank, Conical Bottom
278		Horizontal Storage Tank
280		Storage Tank, Closed Top
281		Storage Tank, Open Top
910-001		Tank Vented to Atmosphere
910-002		Atmospheric Membrane Sealed Tank
910-003		Floating Roof Tank
910-004		Blowdown Tank
		Nuclear Reactor
800		Air Drier

CELL NAME	SYMBOL	DESCRIPTION
VESSELS AND TANKS		
		Cyclone
810		Dust Collectors Precipitators
		Electrical Precipitator
910-007		Rotating Drum Screen
910-008		Pressure Vessel
910-009		Accumulator
910-010		Gas Cylinder
910-011		Tank (Type 1 Reheater)
910-012		Tank (Type 2)
910-013		Floating Roof Membrane Sealed Tank (eg REA)
910-014		Tank (Type 3)

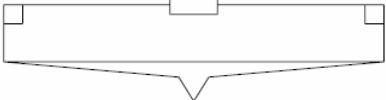



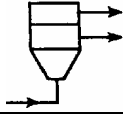

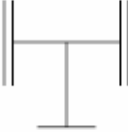

Work Instruction for Process (P&ID, PFD, PPF and SPFD), Hydraulic and Pneumatic Drawings	Unique Identifier:	36-945
	Revision:	0
Classification: Controlled Disclosure	Page:	101 of 117

CELL NAME	SYMBOL	DESCRIPTION
MISCELLANEOUS EQUIPMENT		
282		Bearing
283		Burner
284		Igniter
107		Brake
106		Gearbox
108		Blocking Device
287		Damper
105		Variable Speed Control Coupling
		Clutch Coupling
286		Drum Mill
		Ball Mill
814		General Mill
804		Classifying Cyclone
		Thickener

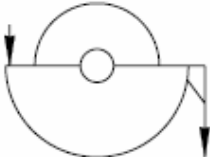

Work Instruction for Process (P&ID, PFD, PPF and SPFD), Hydraulic and Pneumatic Drawings	Unique Identifier:	36-945
	Revision:	0
Classification: Controlled Disclosure	Page:	102 of 117

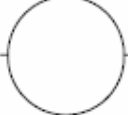
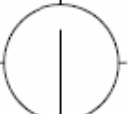
CELL NAME	SYMBOL	DESCRIPTION
MISCELLANEOUS EQUIPMENT		
		Centrifuge
		Centrifuge (Alternative)
		Static Mixer
		Agitator



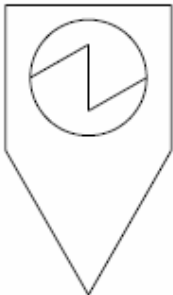

Work Instruction for Process (P&ID, PFD, PPF and SPFD), Hydraulic and Pneumatic Drawings	Unique Identifier:	36-945
	Revision:	0
Classification: Controlled Disclosure	Page:	103 of 117

CELL NAME	SYMBOL	DESCRIPTION
STRAINERS, FILTERS TRAPS AND RECEIVERS		
63		General Strainer
59		T-Type Strainers
58		Y-Type Strainer
47		General Filter
809		Drum Filter
66		Steam Trap
67		Air Trap
40		Absorber Air Drier
259		Steam Receiver
272		Steam Separator
43		Accumulator



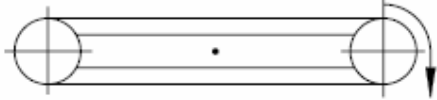

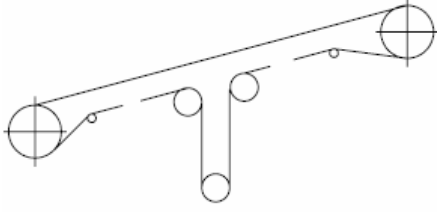
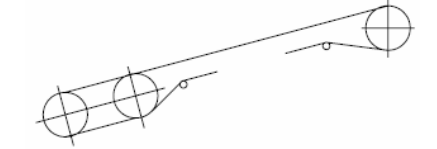

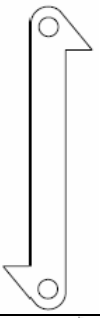
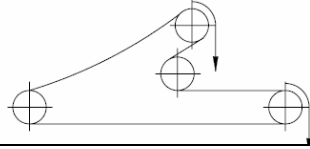
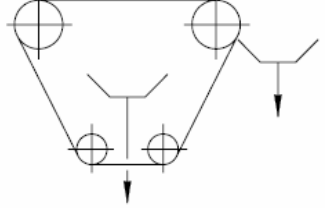

Work Instruction for Process (P&ID, PFD, PPF and SPFD), Hydraulic and Pneumatic Drawings	Unique Identifier:	36-945
	Revision:	0
Classification: Controlled Disclosure	Page:	104 of 117

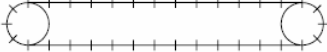
CELL NAME	SYMBOL	DESCRIPTION
		Mist Lubricator
		Flash Box
289		Electro-Static Precipitator

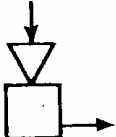

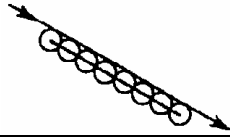
Work Instruction for Process (P&ID, PFD, PPF and SPFD), Hydraulic and Pneumatic Drawings	Unique Identifier:	36-945
	Revision:	0
Classification: Controlled Disclosure	Page:	105 of 117

CELL NAME	SYMBOL	DESCRIPTION
CONVEYORS		
801		Belt Conveyor
806		Conveyor
828		Vertical Gravity Take-Up Conveyor
820		Screw Take-up Conveyor
805		Apron Feeder
803		Bucket Elevator
827		Tripper Conveyor
802		Belt Filter





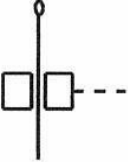
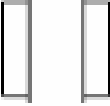
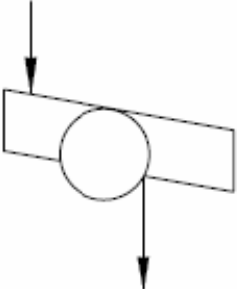
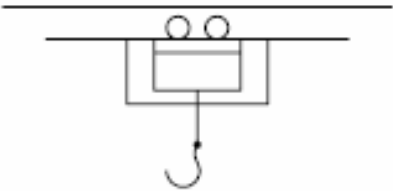
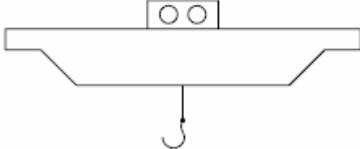

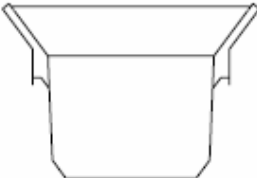
Work Instruction for Process (P&ID, PFD, PPF and SPFD), Hydraulic and Pneumatic Drawings	Unique Identifier:	36-945
	Revision:	0
Classification: Controlled Disclosure	Page:	106 of 117

CELL NAME	SYMBOL	DESCRIPTION
819		Screw Feeder
818		Scraper Conveyor
		Screw Conveyor
		Feeder & Hopper
		Rotary Feeder
		Roller Conveyor
830		Vibrating Feeder
825		Table Feeder
		Idlers

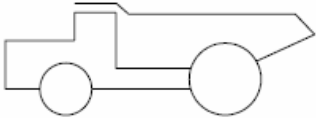

Work Instruction for Process (P&ID, PFD, PPF and SPFD), Hydraulic and Pneumatic Drawings	Unique Identifier:	36-945
	Revision:	0
Classification: Controlled Disclosure	Page:	107 of 117

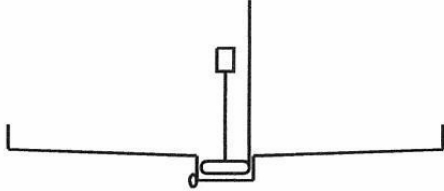
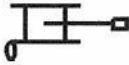
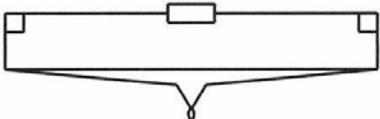
CELL NAME	SYMBOL	DESCRIPTION
ASH AND COAL PLANT GENERAL EQUIPMENT		
807		Demagnetising Coil
808		Density Recorder
813		Magnetising Coil
812		Grizzly Feeder
815		Mono Rail Hoist
816		Overhead Electric Travelling Crane
821		Skip Hoist
811		General Skip General Purpose Container

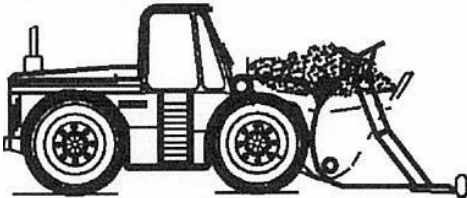
Work Instruction for Process (P&ID, PFD, PPF and SPFD), Hydraulic and Pneumatic Drawings	Unique Identifier:	36-945
	Revision:	0
Classification: Controlled Disclosure	Page:	108 of 117

CELL NAME	SYMBOL	DESCRIPTION
824		Stock Pile
817		Rear Dump Truck
831		Weighbridge
823		Sprays
		Sump
829		Vertical Spindle Sump Pump
822		Sliding Gate
826		Thickener
163		Man
153		Front End Loader



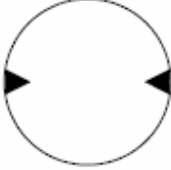



Work Instruction for Process (P&ID, PFD, PPF and SPFD), Hydraulic and Pneumatic Drawings	Unique Identifier:	36-945
	Revision:	0
Classification: Controlled Disclosure	Page:	109 of 117

CELL NAME	SYMBOL	DESCRIPTION
HYDRAULIC EQUIPMENT		
		Single Acting Hydraulic Actuator
		Double-Acting Hydraulic Actuator
		Double Acting Hydraulic Actuator with Different Actuator Areas
		Actuator or Hydraulic Motor with Alternating Directions of Flow

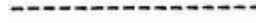
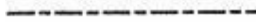



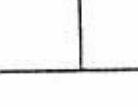
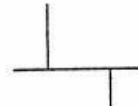
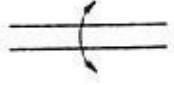
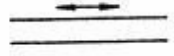

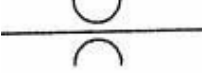

Work Instruction for Process (P&ID, PFD, PPF and SPFD), Hydraulic and Pneumatic Drawings	Unique Identifier:	36-945
	Revision:	0
Classification: Controlled Disclosure	Page:	110 of 117

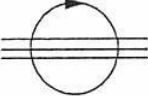
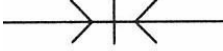
ANNEXURE B

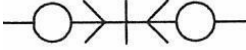
STANDARD CELL LIBRARY FOR HYDRAULIC AND PNEUMATIC DIAGRAMS

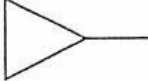
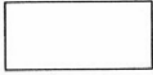
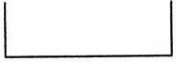
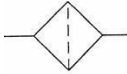
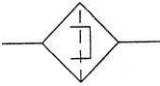
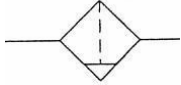
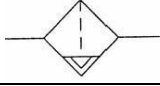

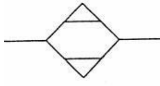
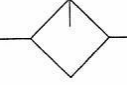
CELL NAME	SYMBOL	DESCRIPTION
HYDRAULIC LINES		
		Solid Line: Main Line Conductor or Shaft
		Dashed Line: Pilot Line to Show Connection
		Centre Line: To Define Enclosures
		Crossing Lines: To Show that lines are NOT connected
		Joining Lines (Shown either touching or with a connector)
		
		
		
		
		Rotation of Shaft
		Movemeng of Shaft/Cylinder
		Flexible Line
		Pneumatic Line with Direction Indicator
		Restricted Line

Work Instruction for Process (P&ID, PFD, PPF and SPFD), Hydraulic and Pneumatic Drawings	Unique Identifier:	36-945
	Revision:	0
Classification: Controlled Disclosure	Page:	111 of 117

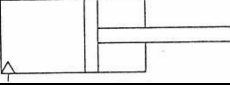
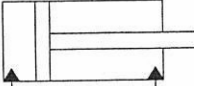
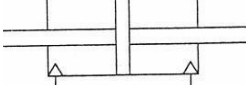
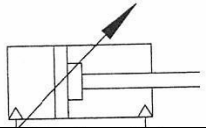
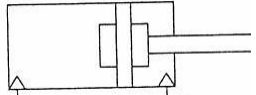
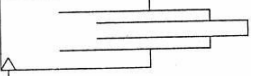
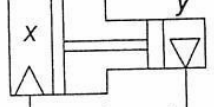

CELL NAME	SYMBOL	DESCRIPTION
HYDRAULIC COUPLINGS		
		Rotating Coupling
		Connected Conductor, No Check Valves
		Disconnected Conductor, No Check Valves
		Connected Conductor, With Check Valves
		Disconnected Conductor, With Check Valves
FLUID STORAGE AND ENERGY SOURCES		
		Air Receiver
		Energy Source
		Closed Tank Pressurised Tank
		Open Tank
FLUID CONDITIONERS		
		Filter
		Magnetic Element Filter
		Separator: Manual Drain with Filter
		Separator: Automatic Drain with Filter
		Separator: Automatic Drain without Filter
		Air Dryer
6-014		Lubricator
6-013		Air Lubricator

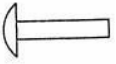
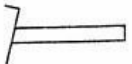
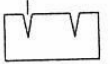
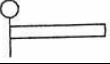

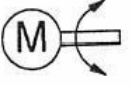

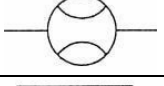
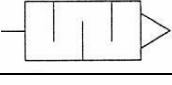
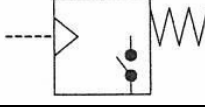
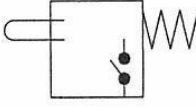
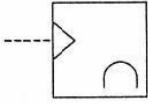

Work Instruction for Process (P&ID, PFD, PPF and SPFD), Hydraulic and Pneumatic Drawings	Unique Identifier:	36-945
	Revision:	0
Classification: Controlled Disclosure	Page:	112 of 117

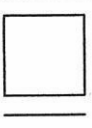
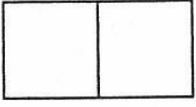
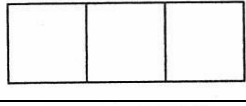
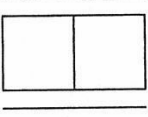
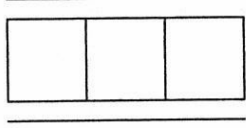
CELL NAME	SYMBOL	DESCRIPTION
CYLINDERS/LINEAR DEVICES		
		Single Acting Cylinder, Spring Operated
		Single Acting Cylinder, Pneumatically Operated
		Double Acting Cylinder, Hydraulically Operated
		Double Acting Cylinder with Double-End Rod, Pneumatically Operated
		Double Acting Cylinder, Adjustable Cushion, Advance Only, Pneumatically Operated
		Double Acting Cylinder, Fixed Cushion, Advance and Retract, Pneumatically Operated
		Telescopic Cylinder, Pneumatically Operated
		Pressure Booster Intensifier

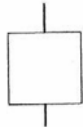
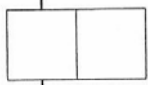

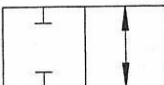
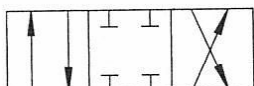
CELL NAME	SYMBOL	DESCRIPTION
ACTUATORS AND CONTROLS		
		Push Button
		Pedal Operated
		Detent
		Lever Operated
		Spring Operated
		Solenoid
		Motor Driven/Operated

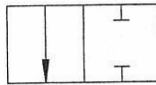
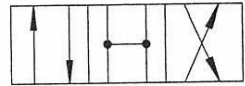
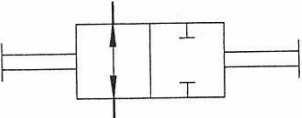
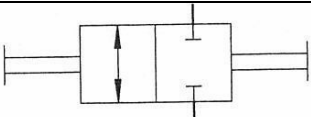
Work Instruction for Process (P&ID, PFD, PPF and SPFD), Hydraulic and Pneumatic Drawings	Unique Identifier:	36-945
	Revision:	0
Classification: Controlled Disclosure	Page:	113 of 117

CELL NAME	SYMBOL	DESCRIPTION
INSTRUMENTS AND ACCESSORIES		
		Pressure Gauge
		Flow Meter
		Silencer
		Pressure Switch, Spring Operated
		Limit Switch, Spring Operated
		Transducer
		Flow Indicator
HYDRAULIC AND PNEUMATIC VALVES		
		Single Envelope, Finite
		Single Envelope, Infinite
		Multiple Envelope, Finite
		
		Multiple Envelope, Infinite
		

CELL NAME	SYMBOL	DESCRIPTION
HYDRAULIC AND PNEUMATIC VALVES		
		
		Envelopes With Ports
		
		Ports Blocked Internally
		
		
		Ports Open Internally
		
		
		Two-Way Valve, Manual Shut-off, "On" Position
		Two-Way Valve, Manual Shut-off, "Off" Position
		Manual Valve, Normally Closed
		Manual Valve, Normally Open

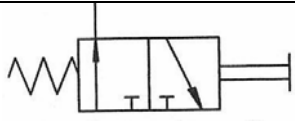
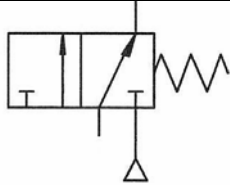
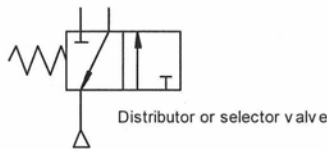
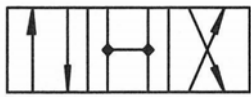
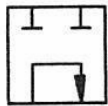
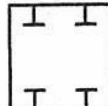
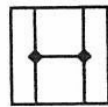
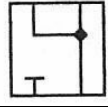
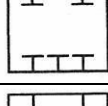
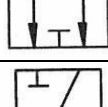
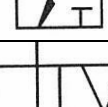
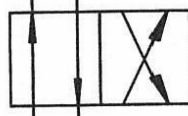
Work Instruction for Process (P&ID, PFD, PPF and SPFD), Hydraulic and Pneumatic Drawings	Unique Identifier:	36-945
	Revision:	0
	Page:	115 of 117

CELL NAME	SYMBOL	DESCRIPTION	
HYDRAULIC AND PNEUMATIC VALVES			
		Three Way Valve, Normally Open, Two-Position	
		Three Way Valve, Normally Closed, Two-Position	
		Distributor Valve Selector Valve	
		Four-Way Valve, General	
		Typical Flow Paths for Centre Positions of 4-way Valves	
			
			
			
			
			
			
			2-Position, 4-Way Valve, Normal Position
			2-Position, 5-Way Valve, Normal Position

Work Instruction for Process (P&ID, PFD, PPF and SPFD), Hydraulic and Pneumatic Drawings	Unique Identifier:	36-945
	Revision:	0
Classification: Controlled Disclosure	Page:	116 of 117

CELL NAME	SYMBOL	DESCRIPTION
HYDRAULIC AND PNEUMATIC VALVES		
		3-Position, 4-Way Valve, Normal Position
		3-Position, 4-Way Valve, Actuated Left Hand Position
		3-Position, 4-Way Valve, Actuated Right Hand Position
		Speed Control Valves

Work Instruction for Process (P&ID, PFD, PPF and SPFD), Hydraulic and Pneumatic Drawings	Unique Identifier:	36-945
	Revision:	0
Classification: Controlled Disclosure	Page:	117 of 117

Revisions Information

Date	Rev.	Remarks
September 2007	0	Revised the requirements for Generation and aligned it with latest drawing office best practice and draughting software requirements. At the same time converted the standard into the Eskom document template, as per the decision of the Generation Document Working group. This standard was previously known as GGS0991, Revision 0.