

BROADBAND INFRACO (SOC) LTD

Dear Sir/Madam,

REQUEST FOR PROPOSALS: INF/TEN: 337

INVITATION TO SUBMIT PROPOSALS FOR APPOINTMENT OF A PANEL OF SERVICE PROVIDERS FOR THE SUPPLY, DELIVERY AND INSTALLATION OF A UPS SYSTEM WITH A SOLAR AND BATTERY BACKUP FOR 340 BROADBAND INFRACO SITES.

Please take note that this is a confidential request, and you are requested to treat all information, including this Request for Proposals as confidential and you must not discuss or divulge this information to any 3rd party without our written permission.

1. BACKGROUND ON BROADBAND INFRACO

Broadband Infraco legislative mandate is set out in the Broadband Infraco Act No. 33 of 2007 (the “Act”). The main objectives as set out in the Act are to expand the availability and affordability of access to electronic communications, including but not limited to underdeveloped and under-serviced areas, in accordance with the Electronic Communications Act and commensurate with international best practice and pricing, through the provision of electronic communications network services and electronic communications services.

In addition, Broadband Infraco must comply with the Public Finance Management Act of 1999 as amended (the “PFMA”), National Treasury Regulations issued in terms of the Public Finance Management Act, and the Companies Act No. 71 of 2008 and other laws that govern the financial affairs, the stability and soundness of the financial system and manage the budget preparation process; and enforce transparency and effective management in respect of revenue and expenditure, assets and liabilities, of the Company.

2. OBJECTIVE

The objective of this Request for Proposal (RFP) is to appoint a panel of service providers for the supply, delivery and installation of a UPS system with a solar and battery backup system for 340 Broadband Infraco sites:

3. LODGING OF TENDER AND CLOSING DATE

Your response under sealed cover and endorsed.

ATTENTION: VALENTIA BALOYI

Must be delivered to **Broadband Infraco** at Sentech Technology Park 2040 Octave Road Radiokop Honeydew before **12h00 noon (RSA Time) on 30 October 2024.**

One original and one copy of the tender **must** be provided on a USB.
All information as per the hard copy proposal must be saved on the **USB.**

NB* If you wish to use courier services, driver, or any other person to deliver your bid document, kindly make sure to inform them to register the bid on the bid register as your bid will not be considered if it is not registered in the bid register.

NB* You or your driver or courier service personnel will be compelled to adhere to all Covid 19 protocols to curb the spread of the virus. The screening check will be done upon arrival. Kindly allow yourself enough time to follow these protocols as no late bids will be accepted due to late coming or late completion of Covid 19 protocols, your bid should be registered by no later than 12:00 noon on the day of closing.

Incomplete information will be rejected and Broadband Infraco will NOT accept late responses

3.1. Any questions which may arise regarding the interpretation of the RFP, or additional information required to clarify the RFP are to be submitted to:

Name: Valentia Baloyi
Address: Sentech Technology Park
2040 Octave Road Radiokop Honeydew
E-Mail: Valentia.baloyi@infraco.co.za

The bidder is requested to refer to the clause and sub-clause number(s) to which its questions relate.

3.2 Please take note that all questions or queries on this RFP must be communicated in writing to Infraco Representative at the above-stated electronic mail address.

In terms of Broadband Infraco Corporate Policy, all questions and queries received will be answered in writing. In the interests of fairness, the question together with Broadband Infraco clarification and/or response thereto will only be made available to

those *bidders* who have submitted a **Receipt of Invitation Form** indicating an intention to tender. The name of the *bidder* who requested clarification and/or posed a question will not be reflected in the clarification and/or response.

3.3 The tender documents are:

3.3.1 This RFP and the documents attached to this RFP as set out in the Document List.

3.3.2 Such addendum, responses to *bidders'* queries and clarifications as may be issued by Broadband Infraco from time to time.

3.4 The provisions of this RFP and Broadband Infraco Standard Conditions of Tender (**Annexure B**) are taken to be mutually explanatory of one another but in the event of ambiguity, discrepancy, divergence, inconsistency or omission from or in or between this RFP and Broadband Infraco Standard Conditions of Tender, the provisions of this RFP shall take precedence over the provisions of Broadband Infraco Standard Conditions of Tender.

3.5 A *bidder* is a Person, Original, Partnership, Agent, Joint Venture, Firm or Company eligible to submit a tender in response to this RFP.

3.6 Broadband Infraco deems that submission of a proposal by a *bidder* in response to this RFP constitutes the *bidder's* acceptance of the Standard Conditions of Tender and the additional terms contained in this RFP.

3.7 Broadband Infraco reservations of rights in respect of the tender:

3.7.1 *Bidders'* attention is specifically drawn to the fact that a contract in respect of the Employer's Requirements will not necessarily result from the tender responses Broadband Infraco receives in response to this RFP. Broadband Infraco reserves the right to conduct a further procurement process with or without a request for tender or to enter into negotiations with any one or more of the *bidders*, should it decide to proceed with contract award.

3.7.2 Broadband Infraco reserves the right to subject *bidders* and their facilities to assessment as part of the evaluation process or as a condition of the contract award.

3.7.3 Broadband Infraco reserves the right not to evaluate and/or consider any proposal by a *bidder* that do not comply strictly with the requirements as set out in this RFP and/or who do not meet one or more of the prerequisite tender requirements set out in the Specification (**Annexure I**).

3.7.4 Broadband Infraco reserves the right to decide on the contract award based solely on the information received in the responses to this RFP. Broadband Infraco also reserves the right to use relevant information not contained in any tender, but which is within the knowledge of any employee or Board member of Broadband Infraco or its advisors, agents or representatives for the purposes of making its decision.

3.8 Disclaimer of liability for representations, warranties or statements

Broadband Infraco believes all information contained in this RFP (and all its schedules and annexes) and all guidelines or in any other written material furnished or information orally transmitted to a potential *bidder* (including, but not limited to any opinion, information or advice that may be provided to a potential *bidder* by or on behalf of Broadband Infraco) to be correct but Broadband Infraco does not (save to the extent otherwise expressly provided for in a future written agreement with a successful *bidder*) make any representations or warranties, express or implied as to the accuracy or completeness of such information and expressly disclaims any and all liability for such representations, warranties or statements.

3.9 Broad-based Black Economic Empowerment

Broadband Infraco requires all interested parties to provide their valid Broad Based Black Economic Empowerment status from a verified agency, sworn affidavits from QSEs and EMEs.

The *Employer* is committed to Broad-Based Black Economic Empowerment principles and as such complies to the BEE Codes of Good Practice published by the Department of Trade Industry (DTI). The bidder is expected to be evaluated on these principles and must present a valid BBEE status certificate and B-BBEE Scorecard based on the DTI Interpretative Guide to the Codes of Good Practice.

<http://www.thedti.gov.za/bee/InterpretiveGuide28june07doc.pdf>

4 KEY TENDER DATES

4.1 The following key tender dates are applicable to this tender:

Table 1: Publication dates

Activity	Key Tender Dates
Tender publication date:	08 October 2024
Compulsory Briefing Session	17 October 2024 @ 11:00
Briefing Venue	Virtual Teams
Link	Microsoft Teams Need help? Join the meeting now Meeting ID: 347 678 753 297 Passcode: GzD2L4
Closing date for written clarifications	23 October 2024
Deadline for responding to questions	28 October 2024

RFP closing date	30 October 2024 @ 12:00 Noon
------------------	-------------------------------------

4.2 The validity period of the tender is one hundred and twenty (120) days from the tender closing date with the possibility of extension should it be necessary to allow the evaluation process.

4.3. Bidders Obligations

Number of copies required. A two-envelope system will be followed in which the FIRST envelope will contain all the mandatory requirements documents and the technical proposal, while the SECOND envelope will contain the financial offer / Pricing.

4.4. Required information for evaluation.

Make available all the information in the response indicating compliance and/or non-compliance with each item required by the bid.

Acknowledging that non-submission of information required to evaluate administrative and functionality will disqualify or prejudice the bidder in claiming and getting points where points are allocated.

A hard copy of each tender must be submitted as an original along with one (1) additional hard copy and one electronic copy of the complete tender on USB.

4.5. Compliance and deviations

Indicate clearly which item of the bid is not quoted for or any deviations to the scope and specification of this bid.

The bidder must ensure that the bid file consists of the following:

- Index that clearly indicates where to find which document.
- File dividers to separate each section of your file as per your index.

5. CONDITIONS OF THE CONTRACT

Broadband Infracore will only accept proposals from interested parties that are prepared to accept and comply with the contract conditions as per the NEC3 Professional Services Contracts (PSC3), as published by Thomas Telford Publishing on behalf of the Institution of Civil Engineers, United Kingdom. Copies available from Thomas Telford Ltd, 1 Heron Quay, London. (ISBN 0 7277 2634 X).

In South Africa, the published NEC can be purchased from Thomas Telford Publications, telephone number (011) 803 3008, and fax number (011) 803 3009.

6. SCOPE OF WORK

Invitation to submit proposals for the appointment a panel of service providers for the supply, delivery and installation of a UPS system with a solar and battery backup system for 340 Broadband Infracore sites.**(Please refer to Annexure I: Specification).**

7. EVALUATION CRITERIA

Bidder/s proposal/s will be evaluated in three (3) phases as follows.

- **Phase 1. Administrative requirements**

Administrative requirements of the bid (*see annexures C, for detailed administrative of the bid*).

- **Phase 2. Technical/functionality evaluation requirements (75% minimum threshold)** (*see annexures c, for detailed technical functionality requirements of the bid*). Failure to meet the minimum threshold will result in disqualification from further evaluation.

Compliance with the technical specification requirements of the bid in terms of accreditations, and submission of all required information.

- **Phase 3. Price and Specific Goals**

Points for this tender shall be awarded for price and specific goals in terms of PPR 2022.

8. INSURANCE

Provide details of local as well as international professional indemnity insurance (Not applicable).

9. JOINT VENTURES/DISTRIBUTORS/AGENTS

In the event that a proposal is submitted by a consortium/joint venture, each party, consultant and or sub-contractor of such consortium/joint venture must complete or provide each of the documents mentioned below: -

- Company Registration Document and certified ID copies of directors/partners/members
- Fully completed SBD Forms
- Valid Tax Certificate
- Tax Pin Compliance Status Letter obtainable from SARS

- CSD Report
- Company profile
- JV Agreement
- Valid consolidated B-BBEE certificate/Affidavit.

10. COMPANY INFORMATION REQUIRED

10.1 Table 2: General Data

Registered Company Name	
Postal Address	
Contact Person	
Position in the Company	
Telephone number	
E-Mail address	

10.2. SARS Certificate (for South African registered companies only)

Bidder is required to provide Broadband Infraco with the Tax compliance status verification PIN (Third party authorization) to be used by Broadband Infraco to verify the bidder's tax compliance status.

Bidder is required to provide Broadband Infraco with the Central Supplier Database Master Registration Number (MAAA number) to verify the bidder's tax compliance status.

10.3. Shareholding and Directors

The firm must indicate the nature of the shareholding of the firm and provide the names of directors of the firm, and must indicate percentage owned by Black Women, Black youth and disabled people.

10.4. National Treasury List of Restricted Service Providers

No bid will be awarded to a person or company who has been listed in the National treasury lists of restricted service provider/suppliers as updated by National treasury.

10.5. National Treasury's Central Supplier Database (NT - CSD)

With effect from 1 April 2016, accounting officers and accounting authorities may not award any bid to a supplier/service provider not registered as a prospective supplier on the National Treasury's Central Supplier Database.

Bidder is required to provide Broadband Infraco with the Central Supplier Database Master Registration Number (MAAA number) or bidder's CSD report.

11. DISCUSSIONS

Broadband Infraco reserves the right to call upon any bidder to discuss or present its proposals as and when deemed necessary at the bidder's cost.

Under no circumstances will a presentation by or negotiation with any bidder constitute an award or promise / undertaking to award the contract.

12. YOUR PROPOSAL

To submit a valid and acceptable proposal to Broadband Infraco, your proposal /offer must include the following:

- Comply with all administrative and functionality evaluation requirements.
- A cover letter on your firm's official letterhead including acceptance of the requirements of the bid and the conditions in the bid document.
- Confirmation that all the mandatory compliance and requirements of the bid have been met with all the required documents submitted.
- Provide your Central Supplier Database report (**Compulsory**).
- Provide a Valid Tax Clearance certificate (**Compulsory**).

13. SPECIAL CONDITIONS OF THIS BID

These special conditions must be read in conjunction with the general conditions and NEC3 conditions that are applicable to this bid.

- The Broadband Infraco reserves the right to suggest partnerships or joint ventures to be formed between bidders, or that the assignment must be awarded to an exclusive BEE firm.
- The Broadband Infraco reserves the right to amend any conditions, validity period, etc. in the event of material changes to the procedures, all parties will be duly notified and dealt with transparently and equitably.
- Other conditions additional to the ones mentioned above will be discussed and agreed upon between Broadband Infraco and the successful bidder/s to prior contracting.

14. SIGNED CONFIDENTIALITY AGREEMENT

The attached confidentiality agreement included in Annexure E must be signed by the person who is authorised to sign on behalf of the firm and **returned** with the response to this RFP.

15. BID APPROVAL

INVITATION TO SUBMIT PROPOSALS FOR APPOINTMENT OF A PANEL OF SERVICE PROVIDERS FOR THE SUPPLY, DELIVERY AND INSTALLATION OF A UPS SYSTEM WITH A SOLAR AND BATTERY BACKUP FOR 340 BROADBAND INFRACO SITES.



Mr. Terence Manzini

Manager – Planning and Performance

Date: 08 October 2024

ANNEXURE A

DOCUMENT LIST

- 1. RFP Document**
- 2. Annexure A : Document list.**
- 3. Annexure B : Broadband Infraco Standard Conditions of Tender.**
- 4. Annexure C : Administrative, Mandatory, and Technical Evaluation**
- 5. Annexure D : Tender Returnable.**
- 6. Annexure E : Confidentiality Agreement.**
- 7. Annexure F : Invitation to Bid (SBD 1)**
- 8. Annexure G : Declaration of Interest (SBD 4)**
- 9. Annexure H : Preferential Procurement claim form (SBD 6.1 2022)**
- 10. Annexure I : Project Scope of Work**
- 11. Annexure J : Price Schedule**
- 12. Annexure K : Receipt of the invitation**
- 13. Annexure L : Team Agreement**



ANNEXURE B

BROADBAND INFRACO SOC LIMITED STANDARD CONDITIONS OF TENDER

January 2008

GENERAL

- | | | |
|--|---|---|
| Actions | 1 | Broadband Infraco (SOC) Ltd (Infraco), Broadband Infraco <i>Representative</i> and each <i>bidder</i> submitting a tender shall act timeously as stated in these Conditions of Tender and in a manner, which is fair, equitable, transparent, competitive and cost-effective. |
| Interpretation | 2 | Terms shown in <i>italics</i> vary for each tender. The details of each term for this tender are identified in the Tender Data. Terms shown in capital initials are defined terms in the appropriate conditions of contract. |
| | 3 | Any additional or amended requirements in the Tender Data and additional requirements given in the Schedules in the tender returnable are deemed to be part of these Conditions of Tender. |
| | 4 | The Conditions of Tender and the Tender Data shall not form part of any contract arising from this invitation to tender. |
| Communication | 5 | Each communication between Broadband Infraco and a <i>bidder</i> shall be to or from Broadband Infraco <i>Representative</i> only, and in a form that can be read, copied and recorded. Communication shall be in the English language. Infraco takes no responsibility for non-receipt of communications from or by a <i>bidder</i> . |
| Broadband Infraco rights to accept or reject any tender | 6 | Broadband Infraco may accept or reject any variation, deviation, tender, or alternative tender, and may cancel the tender process and reject all tenders at any time prior to the formation of a contract. Broadband Infraco or Broadband Infraco <i>Representative</i> will not accept or incur any liability to a <i>bidder</i> for such cancellation and rejection but will give written reasons for the action upon written request to do so. Broadband Infraco reserves the right to accept the whole of any part of any tender. |

After the cancellation of the tender process or the rejection of all tenders Broadband Infraco may abandon the proposed work and services, have it performed in any other manner, or re-issue a similar invitation to tender at any time.

2 BIDDERS OBLIGATIONS

The *bidder* shall comply with the following obligations when submitting a tender and shall:

- | | | |
|---|---|---|
| Eligibility | 1 | Submit a tender only if the <i>bidder</i> complies with the <i>criteria</i> stated in the Tender Data and the <i>bidder</i> , or any of his principals, is not under any restriction to do business with Broadband Infraco. |
| Cost of tendering | 2 | Accept that Broadband Infraco will not compensate the <i>bidder</i> for any costs incurred in the preparation and submission of a tender, including the costs of any testing necessary to demonstrate that aspects of the tender satisfy the evaluation criteria. |
| Check documents | 3 | Check the <i>tender documents</i> on receipt, including pages within them, and notify Broadband Infraco <i>Representative</i> of any discrepancies or omissions using the enclosed fax-back form. |
| Confidentiality a copyright of documents | 4 | Treat as confidential all matters arising in connection with the tender. Use and copy the documents provided by Broadband Infraco only for the purpose of preparing and submitting a tender in response to this invitation. |
| Standardised specifications and other publications | 5 | Obtain, as necessary for submitting a tender, copies of the latest revision of standardised specifications and other publications, which are not attached but which are incorporated into the <i>tender documents</i> by reference. |
| Acknowledge receipt | 6 | Complete the Receipt of invitation and submit the tender fax-back form, which is attached to the Letter of Invitation, and return it within five days of receipt of the invitation. |
| | 7 | Acknowledge receipt of Addenda to the <i>tender documents</i> , which Broadband Infraco <i>Representative</i> may issue, and if necessary, apply for an extension to the <i>deadline for tender submission</i> , in order to take the Addenda into account. |

Site visit and / or clarification meeting	8	Attend a site visit and/or clarification meeting at which <i>bidders</i> may familiarise themselves with the proposed work, services or supply, location, etc. and raise questions. Details of the meeting(s) are stated in the Tender Data.
Seek clarification	9	Request clarification of the <i>tender documents</i> , if necessary, by notifying Broadband Infraco <i>Representative</i> earlier than the <i>closing time for clarification of queries</i> .
Insurance	10	Be informed that the extent (if any) of insurance provided by Broadband Infraco may not be for the full cover required in terms of the relevant category listed in Section 8 of the <i>conditions of contract</i> , the <i>bidder</i> is advised to seek qualified advice regarding insurance.
Pricing the tender	11	Include in the rates, prices, and the tendered total of the prices (if any) all duties, taxes (except VAT), and other levies payable by the successful <i>bidder</i> . Such duties, taxes and levies are those applicable 14 days prior to the <i>deadline for tender submission</i> .
	12	Show Value Added Tax (VAT) payable by Broadband Infraco separately as an addition to the tendered total of the prices.
	13	Provide rates and prices that are fixed for the duration of the contract and not subject to adjustment except as provided for in the <i>conditions of contract</i> .
	14	State the rates and Prices in South African Rand unless instructed otherwise as an additional condition in the Tender Data. The selected <i>conditions of contract</i> may provide for part payment in other currencies.
Alterations to documents	15	Not make any alterations or additions to the <i>tender documents</i> , except to comply with instructions issued by Broadband Infraco <i>Representative</i> or if necessary, to correct errors made by the <i>bidder</i> . All such alterations shall be initialled by all signatories to the tender. Corrections may not be made using correction fluid, correction tape or the like.
Alternative tenders	16	Submit alternative tenders only if a main tender, strictly in accordance with all the requirements of the <i>tender documents</i> is also submitted. The alternative tender is submitted with the main tender together with a schedule that compares the requirements

of the *tender documents* with the alternative requirements the *bidder* proposes.

- 17 Accept that an alternative tender may be based only on the criteria stated in the Tender Data and as acceptable to Broadband Infraco.
- Submitting tender** a 18 Submit a tender for providing the whole of the works, services or supply identified in the Contract Data unless stated otherwise as an additional condition in the Tender Data.
- 19 Return the *tender returnable* to Broadband Infraco, completing without exception all the forms, data and schedules included therein.
- 20 Submit the tender as an original plus the number of copies stated in the Tender Data and provide an English translation for documentation submitted in a language other than English. Tenders may not be written in pencil but must be completed in ink.
- 21 Sign the original and all copies of the tender where indicated. Broadband Infraco will hold the signatory duly authorised and liable on behalf of the *bidder*.
- 22 Seal the original and each copy of the tender as separate packages marking the packages as "ORIGINAL" and "COPY". Each package shall state on the outside Broadband Infraco address and invitation to tender number stated in the Tender Data, as well as the *bidders* name and contact address.
- 23 Seal original and copies together in an outer package that states on the outside only Broadband Infraco address and invitation to tender number as stated in the Tender Data. The outer package must be marked "CONFIDENTIAL"
- 24 Accept that Broadband Infraco will not assume any responsibility for the misplacement or premature opening of the tender if the outer package is not sealed and marked as stated.

Note:

Broadband Infraco prefers not to receive tenders by post and takes no responsibility for delays in the postal system or in transit within or between Broadband Infraco offices.

Where tenders are sent per fax, Broadband Infraco takes no responsibility for difficulties in transmission caused by line or equipment faults.

Where tenders are sent via courier, Broadband Infraco takes no responsibility for tenders delivered to any other site than the tender office.

Broadband Infraco employees are not permitted to deposit a tender into the Broadband Infraco tender box on behalf of a bidder, except those lodged by post or courier.

- Closing time** 26 Ensure that Broadband Infraco has received the tender at the address and in the tender box or fax specified in the Tender Data no later than the *deadline for tender submission*. Proof of posting will not be taken by Broadband Infraco as proof of delivery. Broadband Infraco will not accept a tender submitted telephonically, e-mail or by telegraph unless stated otherwise in the Tender Data.
- 27 Accept that, if Broadband Infraco extends the *deadline for tender submission* for any reason, the requirements of these Conditions of Tender apply equally to the extended deadline.
- Tender validity** 28 Hold the tender(s) valid for acceptance by Broadband Infraco at any time within the *validity period* after the *deadline for tender submission*.
- 29 Extend the *validity period* for a specified additional period if Broadband Infraco requests the *bidder* to extend it. A *bidder* agreeing to the request will not be required or permitted to modify a tender, except to the extent Broadband Infraco may allow for the effects of inflation over the additional period.
- Clarification of tender after submission** 30 Provide, on request from Broadband Infraco *Representative* during the evaluation of tenders, any other material that has a bearing on the tender, the bidders commercial position (including notarised joint venture agreements), preferencing arrangements or samples of materials, considered necessary by Broadband Infraco for the purpose of a full and fair risk assessment. This may include providing a breakdown of rates or Prices. No change in the total of the Prices or substance of the tender is sought, offered, or permitted except as required by Broadband Infraco *Representative* to confirm the correction of arithmetical errors discovered in the evaluation of tenders. The total of the Prices

stated by the *bidder* as corrected by Infraco *Representative* with the concurrence of the *bidder*, shall be binding upon the *bidder*

- Submit bonds, policies etc.** 31 If instructed by Broadband Infraco *Representative* (before the formation of a contract), submit for Infraco acceptance, the bonds, guarantees, policies and certificates of insurance required to be provided by the successful *bidder* in terms of the *conditions of contract*.
- 32 Undertake to check the final draft of the contract provided by Broadband Infraco *Representative* and sign the Form of Agreement all within the time required by these Conditions of Tender.
- 33 Where an agent on behalf of a principal submits a tender, an authenticated copy of the authority to act as an agent must be submitted with the tender.
- Fulfil BEE requirements** 34 Comply with Broadband Infraco requirements regarding BEE and Black Women-owned Suppliers.

3 BROADBAND INFRACO'S UNDERTAKINGS

Broadband Infraco, and Broadband Infraco Representative, shall:

- Respond to clarification** 1 Respond to a request for clarification received earlier than the *closing time for clarification of queries*. The response is notified to all *bidders*.
- Issue Addenda** 2 If necessary, issue Addenda that may amend, amplify, or add to the *tender documents*, to each *bidder*. If a *bidder* applies for an extension to the *deadline for tender submission*, in order to take Addenda into account in preparing a tender, Broadband Infraco may grant such an extension and Broadband Infraco *Representative* shall notify the extension to all *bidders*.
- Return late tenders** 3 Return tenders received after the *deadline for tender submission* unopened to the *bidder* submitting a late tender. Tenders will be deemed late if they are not on the designated fax or in the designated tender box at the date and time stipulated as the deadline for tender submission.

Non-disclosure	4	Not disclose to <i>bidders</i> , or to any other person not officially concerned with such processes, information relating to the evaluation and comparison of tenders and recommendations for the award of a contract, until after the award of the contract to the successful bidder.
Grounds for rejection	5	Consider rejecting a tender if there is any effort by a <i>bidder</i> to influence the processing of tenders or contract award.
Disqualification	6	Instantly disqualify a bidder (and his tender) if it is established that the bidder offered an inducement to any person with a view to influencing the placing of a contract arising from this invitation to tender.
Test for responsiveness	7	Determine before detailed evaluation, whether each tender properly received. meets the requirements of these Conditions of Tender, has been properly signed, and is responsive to the requirements of the <i>tender documents</i> .
	8	Judge a <i>responsive tender</i> as one which conforms to all the terms, conditions, and specifications of the <i>tender documents</i> without material deviation or qualification. A material deviation or qualification is one which, in Broadband Infraco opinion would detrimentally affect the scope, quality, or performance of the works, services or supply identified in the Contract Data, change Broadband Infraco or the <i>bidders</i> risks and responsibilities under the contract, or affect the competitive position of other <i>bidders</i> presenting responsive tenders if it were to be rectified.
Non-responsive tenders	9	Reject a non-responsive tender, and not allow it to be subsequently made responsive by correction or withdrawal of the non-conforming deviation or reservation.
Arithmetical errors	10	Check responsive tenders for arithmetical errors, correcting them as follows: Where there is a discrepancy between the amounts in figures and in words, the amount in words shall govern. If a bill of quantities applies and there is a discrepancy between the rate and the line item total, resulting from multiplying the rate by the quantity, the rate as quoted shall

govern. Where there is an obviously gross misplacement of the decimal point in the rate, the line item total as quoted shall govern, and the rate will be corrected.

Where there is an error in the total of the Prices, either as a result of other corrections required by this checking process or in the *bidder's* addition of prices, the total of the Prices, if any, will be corrected.

The corrected price will be communicated to the bidder. The bidder may withdraw the tender but may not change the tendered price.

- | | | |
|---------------------------------------|----|---|
| | 11 | Reject a tender if the <i>bidder</i> does not accept the corrected total of the Prices (if any). |
| Evaluating the tender | 12 | Evaluate responsive tenders in accordance with the <i>procedure and criteria</i> stated in the Tender Data. The evaluated tender price will be disclosed only to the relevant Infraco tender committee and will not be disclosed to <i>bidders</i> or any other person. |
| Clarification of a tender | 13 | Obtain from a <i>bidder</i> clarification of any matter in the tender which may not be clear or could give rise to ambiguity in a contract arising from this tender if the matter were not to be clarified. |
| Acceptance of tender | 14 | Notify Broadband Infraco's acceptance to the successful <i>bidder</i> before the expiry of the <i>validity period</i> or agreed additional period. Providing the notice of acceptance does not contain any qualifying statements, it will constitute the formation of a contract between Broadband Infraco and the successful <i>bidder</i> . |
| Notice to unsuccessful bidders | 15 | After the successful <i>bidder</i> has acknowledged Broadband Infraco's notice of acceptance, notify other <i>bidders</i> that their tenders have not been accepted, following Infraco's current procedures. |
| Prepare contract documents | 16 | Revise the contract documents issued by Broadband Infraco as part of the <i>tender documents</i> to take account of Addenda issued during the tender period, inclusion of some of the <i>tender returnable</i> , and |

other revisions agreed between Broadband Infraco and the successful *bidder*, before the issue of Broadband Infraco's notice of acceptance (of the tender).

The schedule of deviations attached to the form of offer and acceptance, if any.

- | | | |
|--|----|---|
| Issue final contract | 17 | Issue the final contract documents to the successful <i>bidder</i> for acceptance within one week of the date of Broadband Infraco's notice of acceptance. |
| Sign Form of Agreement | 18 | Arrange for authorised signatories of both parties to complete and sign the original and one copy of the Form of Agreement within two weeks of the date of Broadband Infraco's notice of acceptance of the tender. If either party requires the signatories to initial every page of the contract documents, the signatories for the other party comply with the request. |
| Complete Adjudicator's Contract | 19 | Unless alternative arrangements have been agreed, arrange for both parties to complete and sign the Form of Agreement and Contract Data for the NEC Adjudicator's Contract with the selected adjudicator. |
| Provide copies of the contracts | 20 | Provide to the successful <i>bidder</i> the number of copies stated in the Tender Data of the signed copy of the contracts within three weeks of the date of Broadband Infraco acceptance of the tender. |

ANNEXURE C - BID EVALUATION METHODOLOGY

1.1. The Evaluation will be conducted in three (03) phases, as follows:

Points will be allocated for the evaluation criteria as discussed in this RFP; bidders will be ranked in terms of the overall score attained in terms of the PPPFA Act.

1.2. Phase 1 –Administrative Requirements

Bidders must provide all fully, completed and signed administrative documents listed in this RFP document.

Table 3: Administrative Requirements

1.1.1 Completion and submission of SBD 1 - Annexure F	Comply	Not comply
Bidders must provide completed and signed SBD 1 – “Invitation to Bid”.		
Substantiate/Comment		
1.1.2 Completion and submission of SBD 4 - Annexure G	Comply	Not comply
Bidders must provide completed and signed SBD 4 – “Declaration of interest”.		
Substantiate/Comment		
1.1.3 Completion and submission of SBD 6.1 - Annexure H	Comply	Not comply
Bidders must provide completed and signed SBD 6.1 – “Preference Points Claim Form in terms of the preferential procurement regulations 2022”		
Substantiate/Comment <i>(Please indicate if the portion of the contract will be subcontracted and the %)</i>		
1.1.4 National Treasury Central Supplier Database (CSD)	Comply	Not comply
With effect from 1 April 2016, Accounting Officers and Accounting Authorities may not award any bid to a supplier/service provider not registered as a prospective supplier on the National Treasury’s Central Supplier Database. Please attach the full report of the Central Supplier Database (CSD) from the National Treasury to the bid response. Please provide proof of registration with National Treasury.		
Substantiate/Comment		

1.1.5 South African Revenue Services Certificate	Comply	Not comply
Bidder is required to submit an authorisation PIN as provided by the tax authority as verification information to be used by Broadband Infracore to validate SARS matters on the website.		
Substantiate/Comment		
1.1.6 TEAMING AGREEMENT	Comply	Not comply
Bidders are required to submit a teaming agreement in Annexure L(JV or Consortium)		
Substantiate/Comment		
1.1.7 Compulsory Briefing Session	Comply	Not comply
Bidders are requested to attend compulsory briefing session. NOTE: Failure to attend the compulsory briefing session will lead to automatic disqualification.		
Substantiate/Comment		

1.3. PHASE 2 – TECHNICAL EVALUATION

Technical/Functionality evaluation will be in accordance with the criteria below. Bidder/s must achieve a minimum threshold of **75** points to be considered for further evaluation.

Bidders who achieve the minimum threshold of **75** out of 100 points will be subject to site inspection.

Table 4: Functionality Evaluation Criteria

Section	Criteria	Sub Criteria	Sub Weight	Weight
Solution Overview	Service provider to supply, delivery and install of a complete UPS system with a solar and battery backup system for 340 sites on the USAASA phase 1, 2 and 3 sites in the following districts	Service provider agrees to supply a suitable UPS system with a solar and battery backup system for 340 sites	5	5
	Dr Ruth Segomotsi Mompati District 332;	Yes	0	
	Special schools – 8	No		
Solution functionality	The UPS system with a solar and battery backup system solution to be deployed, shall supports pass-through charging (being charged and discharged simultaneously).	System supports pass-through charging	3	6
		System doesn't supports Pass through charging	0	
	It should consist of dual inputs and be able to work from both inputs i.e Normal gird and a solar panel input.	System has Dual inputs	3	
		System only works from solar	0	
		System only works from Mains	0	
Mains	Mains power inputs i.e Normal AC gird shall be 230V input with a power rating of minimum 300Watts. (Brochure/datasheet to be supplied)	Mains input power rating		5
		≥300 Watts	2	

		≥400 Watts	5	
		≤300 Watts	0	
Solar Panel Input	Solar panel input on regulator shall be 300Watts minimum (Brochure/datasheet to be supplied)	Solar input power rating on regulator 300Watts	2	5
		≥450 Watts	5	
		<300 Watts	0	
Solar Panel (Brochure/datasheet to be supplied)	Solar Panel Type: Tier 1 Monocrystalline	Tier 1 Monocrystalline	3	14
		Polycrystalline or thinfilm or any other type	1	
	Solar Panel Power Output: >150W and be able to charge battery full in typical 8 hours	Rating <150W for all system	0	
		Rating ≥150W for all system	2	
		Rating ≥150W for scenario 1 and 2 and Rating ≥ 200W for scenario 3 and 4	3	
		Rating ≥ 200W for all systems	4	
		Rating ≥150W for scenario 1 and 2 Rating ≥ 250W for scenario 3 and 4	5	
		Rating ≥200W for scenario 1 and 2 Rating ≥ 250W for scenario 3 and 4	8	
	Solar Panel: 12-year warrantee. (Brochure/datasheet to be supplied)	Warrantee 12Y	3	
		Warrantee less than 12Y	0	
Type: Lithium Iron Phosphate (LiFePO4)	Battery type LiFePO4	5	16	
	Any other type	0		

Battery (Brochure/datasheet to be supplied)	Capacity: 50Ah (at 12V) Preferred \geq 75Ah battery Capacity to have a standby time of typical 8 hours	Rating \geq 12V50Ah for all system	2	
		Rating 12V50Ah for scenario 1 and 2 Rating \geq 12V75Ah for scenario 3 and 4	5	
		Smaller capacities	0	
	Cycle Life: \geq 2000 cycles with 80% depth of discharge	Cycles \geq 2000	3	
		Cycles \leq 2000	0	
	Battery: 3 year warrantee (Brochure/datasheet to be supplied)	Warrantee 3Y	3	
Warrantee less than 3Y		0		
Controller (Brochure/datasheet to be supplied)	Type: Maximum Power Point Tracking (MPPT)	MPPT charge	4	13
	Input Voltage: To be compatible with the proposed solar panel voltage as a minimum and the mains AC grid of 230V \pm 10%.	PWM charge	0	
		Output Voltage: Typically 12V – 14.5V DC with a nominal 12V. To be compatible with the proposed battery charging regime	Output voltage Nominal 12V	
	Any other voltage		0	
	Warrentee of controller to be minimum 24 months	Warrantee 2Y	3	
		Warrantee less than 2Y	0	
	Protection provided for overcharge, Over discharge, Over temperature and Short Circuit and reverse battery polarity and correct build-in Intelligent charging algorithm and battery management system for charging the battery and powering the equipment (Brochure/datasheet to be supplied)	Full compliance to protection	4	
		Some protection provided	2	
		No protection provided	0	
		Pole Mount: Adjustable for different angles	Pole and wall mount available with different angles	

Mounting Hardware or proposal to be provided)	Wall Mount: Adjustable for different angles	Pole and wall mount available with fix angle	0	
	Barbwire/lockable mesh or equivalent provided for protection against theft and vandalism. (Picture and or proposal to be provided)	Barbwire/lockable mesh or equivalent provided	3	
		Some protection provided	1	
		No protection provided	0	
Enclosure (Picture and or proposal to be provided)	System for controller and battery and connections to the solar panel to be installed in one suitable indoor wall mounted enclosure with a minimum internal size of 12U. Efficient air flow in the cabinet is required with vents at the side panels. Cabinet to be compliant to NE-NT-SP-0001	Suitable enclosure provided and lockable and miimum height of 12U, Efficient air flow in the cabinet with vents. at the side panels. Cabinet to be power coated and lockable (no glass door allowed), earth bar installed and cable entries to be at the base with removable covers. Cabinet to be compliant to NE-NT-SP-0001	3	3
	Cabinet to be power coated and lockable (no glass door allowed)	No enclosure provided	0	
	Cable entries to be at the base with removable covers			
	Earth bar installed			
	(Picture and or proposal to be provided)			
Indicators (Brochure/datasheet to be supplied)	LED/LCD Indicators for the following minimum conditions:	Correct indicators provided	4	4
	System operation OK and/or fault present;	Some indicators provided	1	
	Solar present and Mains present; and	No indicators provided	0	
	Battery Status/charging/not charging.			
Monitoring (Brochure/datasheet to be supplied)	Real-time Monitoring available: Solar power generation, battery status, load consumption, and WiFi/Remote connectivity	Real time monitoring with WIFI/Remote connectivity	5	5
		No Real time monitoring and/or WIFI/Remote connectivity	0	

Cabling	Solar flex cables to be used to connect solar panels with MC4 connectors – minimum 6mm ²	Correct cable, cable sizes provided	2	2
	Battery Cable: Suitable connectors with minimum 10mm ²	Wrong cable type used	0	
Installation	Electrical Certificate of Compliance	Electrical CoC provided for each system	4	4
		No CoC	0	
Project Management Plan	Detailed project management highlighting how the project will be managed	Project Management Plan provided	4	4
		No Project Management Plan provided	0	
Project Management Schedule	Project Management Schedule (Indicative)	Project Management Schedule provided and is less than 3 months	4	4
		Project Management Schedule provided and is less than 2 months	3	
		No Project Management Schedule provided or schedule more than 3 months	0	
Qualifications	Electrical Certificate of Compliance	Sign of the Sites – ECSA Registered or Equivalent and Installations- Master Electrician to oversee the installations	4	4
		Installations- Master Electrician to oversee the installations but no ECSA Registered or Equivalent	2	
		No ECSA Registered or Master Electrician	0	
		Total Technical Evaluation Criteria	100	
		Minimum threshold requirement	75	

1.4. PHASE 4 – PRICE AND SPECIFIC GOALS

Specific goals for the tender and points claimed are indicated per below:

Table 4: Specific Goals

Specific goals	80/20	"90/10	Acceptable Evidence
Black Owned Entity	6	3	CIPS documents + BBBEE Certificate/Certified Affidavit + Certified copy or copies of ID documents of the Owners
Woman Owned Equity	4	2	CIPS documents + BBBEE Certificate/Certified Affidavit + Certified copy or copies of ID documents of the Owners
Youth Equity Ownership	4	2	CIPS documents + BBBEE Certificate/Certified Affidavit + Certified copy or copies of ID documents of the Owners
People With Disability	3	1.5	CIPS documents + BBBEE Certificate/Certified Affidavit + Certified copy or copies of ID documents of the Owners + Medical Letter Confirming Disability
Military Veterans	3	1.5	CIPS documents + BBBEE Certificate/Certified Affidavit + Certified copy or copies of ID documents of the Owners + Certified Personal Registration (CPR) Number
Total Points	20	10	

1.4.1. PRICE EVALUATION

The 80/20 preference point systems will be applied:

A maximum of 80 points is allocated for price on the following basis:

80/20 or 90/10

$$P_s = 80 \left(1 - \frac{P_t - P_{min}}{P_{min}} \right) \text{ or } P_s = 90 \left(1 - \frac{P_t - P_{min}}{P_{min}} \right)$$

Where

P_s = Points scored for comparative price of bid under consideration
 P_t = Comparative price of bid under consideration
 P_{min} = Comparative price of lowest acceptable bid

1.4.2. Submission of Site Pricing Model

Notes: (applicable to all pricing schedules)

- Pricing must include 15% VAT.
- No optional pricing will be considered for evaluation, bids will be evaluated on the main pricing proposal.

2. Broad-Based Black Economic Empower (B-BBEE) (20)

- Broadband Infracore endeavours to conduct business with BBEE Level 1-2 service providers.
- Bidders who qualify as EMEs in terms of the B-BBEE Act must submit a certificate issued by an Accounting Officer as contemplated in the CCA or a Verification Agency accredited by SANAS or a Registered Auditor. Registered auditors do not need to meet the prerequisite for IRBA's approval for the purpose of conducting verification and issuing EMEs with B-BBEE Status Level Certificates. EMEs can also submit certified sworn affidavit as prescribed by DTI.
- Bidders other than EMEs must submit their original and valid B-BBEE status level verification certificate or a certified copy thereof, substantiating their B-BBEE rating issued by a Registered Auditor approved by IRBA or a Verification Agency accredited by SANAS.
- A trust, consortium or joint venture, will qualify for points for their B-BBEE status level as a legal entity, provided that the entity submits their consolidated B-BBEE status level certificate.
- A trust, consortium or joint venture will qualify for points for their B-BBEE status level as an unincorporated entity, provided that the entity submits their consolidated B-BBEE scorecard as if they were a group structure and that such a consolidated B-BBEE scorecard is prepared for every separate bid.
- Tertiary institutions and public entities will be required to submit their B-BBEE status level certificates in terms of the specialised scorecard contained in the B-BBEE Codes of Good Practice.
- A person awarded a contract may not sub-contract more than 25% of the value of the contract to any other enterprise that does not have an equal or higher B-BBEE status level than the person concerned, unless the contract is subcontracted to an EME that has the capability and ability to execute the contract.

ANNEXURE D - TENDER RETURNABLES CHECKLIST

Supplier:

Bid Number: **INF/TEN/337**

Table 5: Returnable documents

Item Number	DESCRIPTION	YES	NO
1	Full copy of submission and USB		
2	1 tender hard copy, (1 original, 1 copy)		
3	Pricing schedule (Annexure J)		
	General data		
4	Company profile covering all the administrative, technical and functionality requirements of the bid		
5	Signed, completed and submission of All SBD Documents		
6	Valid SARS Tax clearance certificate accompanied by a third-party authorisation PIN as provided by the tax authority to each bidder.		
7	Shareholding and Directors percentage ownership		
8	Signed confidentiality agreement		
9	Acceptance of validity of tender – 120 days from closing of bid		
10	No bid will be awarded to a person or company who has been listed in the National treasury lists of restricted service provider/suppliers as updated by the National treasury.		
11	With effect from 1 April 2016, Accounting Officers and Accounting Authorities may not award any bid to a supplier/service provider not registered as a prospective supplier in the National Treasury's Central Supplier Database. Please attach full Central Supplier Database (CSD) report from National Treasury as part of the bid response.		
12	Mandatory Requirements		
	B-BBEE		
13	Valid B-BBEE status certificate from accredited verification agencies, accounting officers or accredited auditors, Sworn affidavits for QSEs and EMEs.		
	Technical requirements		
14	Relevant industry certification documents		

ANNEXURE E

CONFIDENTIALITY AND NON-DISCLOSURE AGREEMENT

Between

BROADBAND INFRACO SOC LIMITED

And

[NAME OF OTHER PARTY]

THE PARTIES TO THIS AGREEMENT ARE: -

- I. **BROADBAND INFRACO SOC LIMITED** a company incorporated under the laws of the Republic of South Africa, having its registered office at Sentech Technology Park 2040 Octave Road Honeydew Radiokop, Republic of South Africa, with registration number 1989/001763/07 [hereinafter referred to as the “Disclosing Party”).
- II. **NAME OF OTHER PARTY** a company incorporated under the laws of [insert name of country], having its registered office at [registered address], Republic of South Africa, with registration number [insert registration number] [hereinafter referred to as the “Receiving Party”).

Hereinafter individually referred to as a “Party” and jointly as the “Parties”.

NOW THEREFORE, IT IS HEREBY AGREED AS FOLLOWS:

- 1.1 The Disclosing Party intends providing the Receiving Party with certain information relating to the Disclosing Party for tendering for – **INVITATION TO SUBMIT PROPOSALS FOR THE APPOINTMENT OF A PANEL OF SERVICE PROVIDERS FOR THE SUPPLY, DELIVERY AND INSTALLATION OF A UPS SYSTEM WITH A SOLAR AND BATTERY BACKUP FOR 340 BROADBAND INFRACO SITES.**
- 1.2 The parties wish to record the terms and conditions upon which the Disclosing Party shall disclose Confidential Information to the Receiving Party, which terms and conditions shall constitute a binding and enforceable Agreement between the parties and their agents.
- 1.3 Notwithstanding the date of signature hereof, this agreement shall be binding upon the parties with effect from the date upon which the Disclosing Party shall have disclosed any Confidential Information to the Receiving Party, whichever date is the earliest.
- 1.4 Neither this Agreement nor the exchange of information contemplated hereby shall commit either party to continue discussions or to negotiate, or to be legally bound to any potential business relationship. The parties shall only be bound to a business relationship by way of a further definitive written Agreement signed by the Parties.
- 1.5 The party disclosing the Confidential Information shall be known as the “**Disclosing Party**” and the party receiving Confidential Information shall be known as the “**Receiving Party**”.

2. THE CONFIDENTIAL INFORMATION

“**Confidential Information**” shall for the purpose of this Agreement include, without limitation, any technical, commercial or financial information, know-how, trade secrets, processes, machinery, designs, drawings, technical specifications and data relating to the Project (including, but not limited to, the information set out in 1.1 above) in whatever form, relating to the disclosing Party's business practices or the promotion of the disclosing Party's business plans, policies or practices, which information is communicated to the receiving Party, or otherwise acquired by the Receiving Party from the Disclosing Party, during the course of the Parties' commercial interactions, discussions and negotiations with one another, whether such information is formally designated as confidential or not.

3. DISCLOSURE OF CONFIDENTIAL INFORMATION

- 3.1 The Disclosing Party shall only disclose the Confidential Information to the Receiving Party to the extent deemed necessary or desirable by the Disclosing Party in its discretion.
- 3.2 The Parties acknowledge that the Confidential Information is a valuable, special and unique asset proprietary to the Disclosing Party.
- 3.3 The Receiving Party agrees that it will not, during or after the course of its relationship with the disclosing party under this agreement and/or the term of this Agreement, disclose the Confidential Information to any third party for any reason or purpose whatsoever without the prior written consent of the Disclosing Party and to the extent of such authorisation, save in accordance with the provisions of this Agreement. In this Agreement “**third party**” means any party other than the Receiving and Disclosing Parties or their Representatives.
- 3.4 Notwithstanding anything to the contrary contained in this Agreement the Parties agree that the Confidential Information may be disclosed by the Receiving Party to its respective employees, agents, officers, directors, subsidiaries, associated companies, shareholders and advisers (including but not limited to professional financial advisers, legal advisers and auditors) ("Representatives") on a need-to-know basis and for the purposes of the Project; provided that the Receiving Party takes whatever steps are necessary to procure that such Representatives agree to abide by the terms of this Agreement to prevent the unauthorized disclosure of the Confidential Information to third parties. For purposes of this clause, the Receiving Party's Representatives shall be deemed to be acting, in the event of a breach, as the Receiving Party's duly authorized agents.
- 3.5 Except as otherwise contemplated in this Agreement, the Parties agree in favor of one another not to utilize, exploit or in any other manner whatsoever use the Confidential Information disclosed pursuant to the provisions of this Agreement for any purpose

whatsoever other than the Project without the prior written consent of the Disclosing Party.

- 3.6 Accordingly, the Receiving Party agrees to indemnify, defend and hold the Disclosing Party harmless from and against any and all suits, liabilities, causes of action, claims, losses, damages, costs (including, but not limited to, cost of cover, reasonable attorneys' fees and expenses), or expenses of any kind (collectively, "Losses") incurred or suffered by the Disclosing Party and/or its Representatives arising from or in connection with the Receiving Party's unauthorized use or disclosure of the Disclosing Party's Confidential Information in violation of the Agreement.

4. TITLE

All Confidential Information disclosed by the Disclosing Party to the Receiving Party is acknowledged by the Receiving Party to be proprietary and the exclusive property of the Disclosing Party. This Agreement shall not confer any rights of ownership or license on the Receiving Party of whatever nature in the Confidential Information.

5. RESTRICTING ON DISCLOSURE AND USE OF THE CONFIDENTIAL INFORMATION

- 5.1 The Receiving Party undertakes not to use the Confidential Information for any purpose other than:

5.1.1 the Project; and

5.1.2 in accordance with the provisions of this Agreement.

6. STANDARD OF CARE

The Receiving Party agrees that it shall protect the Confidential Information disclosed pursuant to the provisions of this Agreement using the same standard of care that it applies to safeguard its own proprietary, secret or Confidential Information but no less than a reasonable standard of care, and that the Confidential Information shall be stored and handled in such a way as to prevent any unauthorised disclosure thereof.

7. RETURN OF MATERIAL CONTAINING OR PERTAINING TO THE CONFIDENTIAL INFORMATION.

- 7.1 The Disclosing Party may, at any time, and in its sole discretion request the Receiving Party to return any material and/or data in whatever form containing, pertaining to or relating to Confidential Information disclosed pursuant to the terms of this Agreement and may, in addition request the Receiving Party to furnish a written statement to the effect that, upon such return, the Receiving Party has not retained in its possession, or under its control, either directly or indirectly, any such material and/or data.

- 7.2 If it is not practically able to do so, the Receiving Party shall destroy or ensure the destruction of all material and/or data in whatever form relating to the Confidential Information disclosed pursuant to the terms of this Agreement and delete, remove or

erase or use best efforts to ensure the deletion, erasure or removal from any computer or database or document retrieval system under its or the Representatives' possession or control, all Confidential Information and all documents or files containing or reflecting any Confidential Information, in a manner that makes the deleted, removed or erased data permanently irrecoverable. The Receiving Party shall furnish the Disclosing Party with a written statement signed by one of its directors or duly authorized senior officers to the effect that all such material has been destroyed.

7.3 The Receiving Party shall comply with any request by the Disclosing Party in terms of this clause, within 7 (seven) business days of receipt of any such request.

8. EXCLUDED CONFIDENTIAL INFORMATION

The obligations of the Receiving Party pursuant to the provisions of this Agreement shall not apply to any Confidential Information that:

8.1 is known to, or in the possession of the Receiving Party prior to disclosure thereof by the Disclosing Party.

8.2 is or becomes publicly known, otherwise than as a result of a breach of this Agreement by the Receiving Party.

8.3 is developed independently of the Disclosing Party by the Receiving Party in circumstances that do not amount to a breach of the provisions of this Agreement.

8.4 is disclosed by the Receiving Party to satisfy an order of a court of competent jurisdiction or to comply with the provisions of any law or regulation in force from time to time; provided that in these circumstances, the Receiving Party shall advise the Disclosing Party to take whatever steps it deems necessary to protect its interests in this regard and provided further that the Receiving Party will disclose only that portion of the Confidential Information which it is legally required to disclose and the Receiving Party will use its reasonable endeavours to protect the confidentiality of such Confidential Information to the greatest extent possible in the circumstances;

8.5 is disclosed to a third party pursuant to the prior written authorisation and limited to the extent of such approval of the Disclosing Party.

8.6 is received from a third party in circumstances that do not result in a breach of the provisions of this Agreement.

9. TERM

This Agreement shall commence upon the date referred to in paragraph 1.3 and shall endure for a period of 2 (two) years after the date of termination of the relationship between the parties referred to herein.

10. ADDITIONAL ACTION

- 10.1 Each Party to this Agreement shall execute and deliver such other documents and do such other acts and things as may be reasonably necessary or desirable to give effect to the provisions of this Agreement.
- 10.2 Nothing contained in the Agreement shall be construed as creating an obligation on the part of either Party to refrain from entering into a business relationship with any third party. Nothing contained in the Agreement shall be construed as creating a joint venture, partnership or employment relationship between the Parties. Except as specified herein, neither Party shall have the right, power or implied authority to create any obligation or duty (express, implied or otherwise) on behalf of the other Party. For the avoidance of doubt, nothing in this Agreement shall oblige either of the Parties to enter into any agreements or transactions whatsoever.

11. BREACH

In the event that the Receiving Party should breach any of the provisions of this Agreement and fail to remedy such breach within seven (7) business days from date of a written notice to do so, then the Disclosing Party shall be entitled to invoke all remedies available to it in law including, but not limited to, the institution of urgent proceedings as well as any other way of relief appropriate under the circumstances, in any court of competent jurisdiction, in the event of breach or threatened breach of the Agreement and/or an action for damages.

12. AMENDMENTS

No amendment, interpretation or waiver of any of the provisions of this Agreement shall be effective unless reduced in writing and signed by the duly authorised representatives of both Parties.

13. ENFORCEMENT

The failure or delay by the Disclosing Party to enforce or to require the performance at any time of any of the provisions of this Agreement shall not be construed to be a waiver of such provision and shall not affect either the validity of this Agreement or any part hereof or the right of the Disclosing Party to enforce the provisions of this Agreement.

14. HEADINGS

The headings of the clauses of this Agreement are used for convenience only and shall not affect the meaning or construction of the contents of this Agreement.

15. REPRESENTATIONS & WARRANTIES

- 15.1 Each Party represents that it has authority to enter into this Agreement and to do all things necessary to procure the fulfilment of its obligations in terms of this Agreement.
- 15.2 The Disclosing Party warrants that disclosure of the Confidential Information to the Receiving Party:
- 15.2.1 will not result in a breach of any other Agreement to which it is a party; and

15.2.2 will not, to the best of its knowledge and belief, infringe the rights of any third party; and the Disclosing Party hereby indemnifies and holds the Receiving Party harmless against any liability for third party claims on such a basis.

16. ENTIRE AGREEMENT

This Agreement contains the entire agreement of the Parties with respect to the subject matter of this Agreement and supersedes all prior agreements between the Parties, whether written or oral, with respect to the subject matter of this Agreement.\

17. GOVERNING LAW

This Agreement and the relationship of the Parties in connection with the subject matter of this Agreement and each other shall be governed and determined in accordance with the laws of the Republic of South Africa.

18. DOMICILIA AND NOTICES

18.1 The Parties hereby choose *domicilium citandi et executandi* (“domicilium”) for all purposes under the Agreement the addresses set out below:

PARTY	PHYSICAL ADDRESS	POSTAL ADDRESS	TELEPHONE NO.	CONTACT PERSON
BROADBAND INFRACO STATE OWNED COMPANY LIMITED	SENTECH TECHNOLOGY PARK 2040 OCTAVE ROAD RADIOKOP HONEYDEW 2040	Postnet suite 321, private bag x26, Sunninghill, 2157	011 235-1621	VALENTIA BALOYI
INSERT PARTICULARS OF OTHER PARTY				

18.2 Any notice given by one party to the other is deemed to have been received by the addressee:

18.2.1 on the date on which the same was delivered to the addressee's address if delivered by hand; or

18.2.2 on the seventh calendar day after the date of posting if sent by pre-paid registered post to the addressee's address; or

18.2.3 on despatch, if sent to the addressee's then telefax number.

18.3 A party may change that party's address for this purpose, by notice in writing to the other party, such a change of address being effective seven days after the deemed receipt by

the addressee of such written notice, provided that the changed address must be a physical address. A notice will also be necessary in respect of new or changed telefax number.

19. SEVERABILITY

In the event of any one or more of the provisions of this Agreement being held for any reason to be invalid, illegal or unenforceable in any respect, such invalidity, illegality or unenforceability shall not affect any other provision of this Agreement, and this Agreement shall be construed as if such invalid, illegal or unenforceable provisions was not a part of this Agreement, and this Agreement shall be carried out as nearly as possible in accordance with its original terms and intent.

20. ASSIGNMENT

20.1 Neither Party may assign or otherwise transfer any of its rights or obligations under this Agreement to any third party without the prior written consent of the other Party.

20.2 This Agreement shall be binding on and shall inure for the benefit of the successors and permitted assigns and personal representatives (as the case may be of the parties).

21. PUBLICITY

Neither party will make or issue any formal or informal announcement or statement to the press or any third party in connection with this Agreement without the prior written consent of the other Party.

SIGNED by the Parties and witnessed on the following dates and at the following places respectively:

SIGNED at _____ on _____

AS WITNESS:

BROADBAND INFRACO SOC
For: **LIMITED**

DULY AUTHORISED

(NAME OF WITNESS IN PRINT)

[SPECIFY FULL NAME OF SIGNATORY]

SIGNED at _____ on _____

AS WITNESS:

For: **[NAME OF OTHER PARTY]**

DULY AUTHORISED

(NAME OF WITNESS IN PRINT)

[SPECIFY FULL NAME OF SIGNATORY]

ANNEXURE F - STANDARD BIDDING DOCUMENT (SBD 1)

PART A: INVITATION TO BID.

YOU ARE HEREBY INVITED TO BID FOR THE REQUIREMENTS OF BROADBAND INFRACO SOC LIMITED.					
BID NUMBER:	INF/TEN: 337	CLOSING DATE:	30 OCTOBER 2024	CLOSING TIME:	12H00 NOON
DESCRIPTION	INVITATION TO SUBMIT PROPOSALS FOR APPOINTMENT OF A PANEL OF SERVICE PROVIDERS FOR THE SUPPLY, DELIVERY AND INSTALLATION OF A UPS SYSTEM WITH A SOLAR AND BATTERY BACKUP FOR 340 BROADBAND INFRACO SITES.				

SUPPLIER INFORMATION					
NAME OF BIDDER					
POSTAL ADDRESS					
STREET ADDRESS					
TELEPHONE NUMBER	CODE		NUMBER		
CELLPHONE NUMBER					
FACSIMILE NUMBER	CODE		NUMBER		
E-MAIL ADDRESS					
VAT REGISTRATION NUMBER					
TAX CLEARANCE NUMBER					
	TCS PIN:		OR	CSD No:	
B-BBEE STATUS LEVEL VERIFICATION CERTIFICATE [TICK APPLICABLE BOX] IF YES, WHO WAS THE CERTIFICATE ISSUED BY?	<input type="checkbox"/> Yes <input type="checkbox"/> No		B-BBEE STATUS LEVEL SWORN AFFIDAVIT		<input type="checkbox"/> Yes <input type="checkbox"/> No
AN ACCOUNTING OFFICER AS CONTEMPLATED IN THE CLOSE CORPORATION ACT (CCA) AND NAME THE APPLICABLE IN THE TICK BOX	<input type="checkbox"/>	AN ACCOUNTING OFFICER AS CONTEMPLATED IN THE CLOSE CORPORATION ACT (CCA)			
	<input type="checkbox"/>	A VERIFICATION AGENCY ACCREDITED BY THE SOUTH AFRICAN ACCREDITATION SYSTEM (SANAS)			
	<input type="checkbox"/>	A REGISTERED AUDITOR			
		NAME:			

[A B-BBEE STATUS LEVEL VERIFICATION CERTIFICATE/SWORN AFFIDAVIT(FOR EMEs& QSEs) SHALL BE SUBMITTED IN ORDER TO QUALIFY FOR PREFERENCE POINTS FOR B-BBEE]

<p>ARE YOU THE ACCREDITED REPRESENTATIVE IN SOUTH AFRICA FOR THE GOODS /SERVICES /WORKS OFFERED?</p>	<p><input type="checkbox"/> Yes <input type="checkbox"/> No</p> <p>[IF YES ENCLOSE PROOF]</p>	<p>ARE YOU A FOREIGN BASED SUPPLIER FOR THE GOODS /SERVICES /WORKS OFFERED?</p>	<p><input type="checkbox"/> Yes <input type="checkbox"/> No</p> <p>[IF YES ANSWER PART B:3 BELOW]</p>
<p><i>SIGNATURE OF BIDDER</i></p>	<p>.....</p>	<p><i>DATE</i></p>	
<p><i>CAPACITY UNDER WHICH THIS BID IS SIGNED (Attach proof of authority to sign this bid; e.g. resolution of directors, etc.)</i></p>			

NB: FAILURE TO PROVIDE ANY OF THE ABOVE PARTICULARS MAY RENDER THE BID INVALID.

- 1. BID SUBMISSION:**
- 1.1. BIDS SHALL BE DELIVERED BY THE STIPULATED TIME TO THE CORRECT ADDRESS. LATE BIDS WILL NOT BE ACCEPTED FOR CONSIDERATION.
 - 1.2. ALL BIDS SHALL BE SUBMITTED ON THE OFFICIAL FORMS PROVIDED– (NOT TO BE RE-TYPED) OR ONLINE
 - 1.3. BIDDERS SHALL REGISTER ON THE CENTRAL SUPPLIER DATABASE (CSD) TO UPLOAD MANDATORY INFORMATION NAMELY: (BUSINESS REGISTRATION/ DIRECTORSHIP/ MEMBERSHIP/IDENTITY NUMBERS; TAX COMPLIANCE STATUS; AND BANKING INFORMATION FOR VERIFICATION PURPOSES). B-BBEE CERTIFICATE OR SWORN AFFIDAVIT FOR B-BBEE SHALL BE SUBMITTED TO BIDDING INSTITUTION.
 - 1.4. WHERE A BIDDER IS NOT REGISTERED ON THE CSD, MANDATORY INFORMATION NAMELY: (BUSINESS REGISTRATION/ DIRECTORSHIP/ MEMBERSHIP/IDENTITY NUMBERS; TAX COMPLIANCE STATUS MAY NOT BE SUBMITTED WITH THE BID DOCUMENTATION. B-BBEE CERTIFICATE OR SWORN AFFIDAVIT FOR B-BBEE SHALL BE SUBMITTED TO BIDDING INSTITUTION.
 - 1.5. THIS BID IS SUBJECT TO THE PREFERENTIAL PROCUREMENT POLICY FRAMEWORK ACT 2000 AND THE PREFERENTIAL PROCUREMENT REGULATIONS, 2017, THE GENERAL

CONDITIONS OF CONTRACT (GCC) AND, IF APPLICABLE, ANY OTHER LEGISLATION OR SPECIAL CONDITIONS OF CONTRACT.

2. TAX COMPLIANCE REQUIREMENTS

- 2.1 BIDDERS SHALL ENSURE COMPLIANCE WITH THEIR TAX OBLIGATIONS.
- 2.2 BIDDERS ARE REQUIRED TO SUBMIT THEIR UNIQUE PERSONAL IDENTIFICATION NUMBER (PIN) ISSUED BY SARS TO ENABLE THE ORGAN OF STATE TO VIEW THE TAXPAYER'S PROFILE AND TAX STATUS.
- 2.3 APPLICATION FOR TAX COMPLIANCE STATUS (TCS) OR PIN MAY ALSO BE MADE VIA E-FILING. IN ORDER TO USE THIS PROVISION, TAXPAYERS WILL NEED TO REGISTER WITH SARS AS E-FILERS THROUGH THE WEBSITE WWW.SARS.GOV.ZA.
- 2.4 BIDDERS MAY ALSO SUBMIT A PRINTED TCS TOGETHER WITH THE BID.
- 2.5 IN BIDS WHERE CONSORTIA / JOINT VENTURES / SUB-CONTRACTORS ARE INVOLVED, EACH PARTY SHALL SUBMIT A SEPARATE PROOF OF TCS / PIN / CSD NUMBER.
- 2.6 WHERE NO TCS IS AVAILABLE BUT THE BIDDER IS REGISTERED ON THE CENTRAL SUPPLIER DATABASE (CSD), A CSD NUMBER AND PROOF SHALL BE PROVIDED.

3. QUESTIONNAIRE TO BIDDING FOREIGN SUPPLIERS

- 3.1. IS THE BIDDER A RESIDENT OF THE REPUBLIC OF SOUTH AFRICA (RSA)?
 YES NO
- 3.2. DOES THE BIDDER HAVE A BRANCH IN THE RSA? YES
 NO
- 3.3. DOES THE BIDDER HAVE A PERMANENT ESTABLISHMENT IN THE RSA?
 YES NO
- 3.4. DOES THE BIDDER HAVE ANY SOURCE OF INCOME IN THE RSA?
 YES NO

IF THE ANSWER IS "NO" TO ALL OF THE ABOVE, THEN, IT IS NOT A REQUIREMENT TO OBTAIN A TAX COMPLIANCE STATUS / TAX COMPLIANCE SYSTEM PIN CODE FROM THE SOUTH AFRICAN REVENUE SERVICE (SARS) AND IF NOT REGISTER AS PER 2.3 ABOVE.

ANNEXURE F: DECLARATION OF INTEREST FOR TENDERS (SBD 4)

1. PURPOSE OF THE FORM

Any person (natural or juristic) may make an offer or offers in terms of this invitation to bid. In line with the principles of transparency, accountability, impartiality, and ethics as enshrined in the Constitution of the Republic of South Africa and further expressed in various pieces of legislation, it is required for the bidder to make this declaration in respect of the details required hereunder.

Where a person/s are listed in the Register for Tender Defaulters and / or the List of Restricted Suppliers, that person will automatically be disqualified from the bid process.

2. Bidder's declaration

2.1 Is the bidder, or any of its directors / trustees / shareholders / members / partners or any person having a controlling interest¹ in the enterprise, employed by the state? **YES/NO.**

2.1.1 If so, furnish particulars of the names, individual identity numbers, and, if applicable, state employee numbers of sole proprietor/ directors / trustees / shareholders / members/ partners or any person having a controlling interest in the enterprise, in table below.

Full Name	Identity Number	Name of State institution

2.2. Do you, or any person connected with the bidder, have a relationship with any person who is employed by the procuring institution? **YES/NO.**

2.2.1 If so, furnish particulars:

.....
.....

2.3. Does the bidder or any of its directors / trustees / shareholders / members / partners or any person having a controlling interest in the enterprise have any interest in any other related enterprise whether or not.

1 the power, by one person or a group of persons holding the majority of the equity of an enterprise, alternatively, the person/s having the deciding vote or power to influence or to direct the course and decisions of the enterprise.

they are bidding for this contract? **YES/NO**

2.3.1. If so, furnish particulars.

.....
.....

3. **DECLARATION**

I, the undersigned, (name).....
in submitting the accompanying bid, do hereby make the following statements that I certify to be true and complete in every respect:

- 3.2. I have read and I understand the contents of this disclosure;
- 3.2. I understand that the accompanying bid will be disqualified if this disclosure is found not to be true and complete in every respect;
- 3.3. The bidder has arrived at the accompanying bid independently from, and without consultation, communication, agreement or arrangement with any competitor. However, communication between partners in a joint venture or consortium will not be construed as collusive bidding.
- 3.4. In addition, there have been no consultations, communications, agreements or arrangements with any competitor regarding the quality, quantity, specifications, prices, including methods, factors or formulas used to calculate prices, market allocation, the intention or decision to submit or not to submit the bid, bidding with the intention not to win the bid and conditions or delivery particulars of the products or services to which this bid invitation relates.
- 3.5. The terms of the accompanying bid have not been, and will not be, disclosed by the bidder, directly or indirectly, to any competitor, prior to the date and time of the official bid opening or of the awarding of the contract.
- 3.6. There have been no consultations, communications, agreements or arrangements made by the bidder with any official of the procuring institution in relation to this procurement process prior to and during the bidding process except to provide clarification on the bid submitted where so required by the institution; and the bidder was not involved in the drafting of the specifications or terms of reference for this bid.

Joint venture or Consortium means an association of persons for the purpose of combining their expertise, property, capital, efforts, skill and knowledge in an activity for the execution of a contract.

3.6. I am aware that, in addition and without prejudice to any other remedy provided to combat any restrictive practices related to bids and contracts, bids that are suspicious will be reported to the Competition Commission for investigation and possible imposition of administrative penalties in terms of section 59 of the Competition Act No 89 of 1998 and or may be reported to the National Prosecuting Authority (NPA) for criminal investigation and or may be restricted from conducting business with the public sector for a period not exceeding ten (10) years in terms of the Prevention and Combating of Corrupt Activities Act No 12 of 2004 or any other applicable legislation.

I CERTIFY THAT THE INFORMATION FURNISHED IN PARAGRAPHS 1, 2 and 3 ABOVE IS CORRECT. I ACCEPT THAT THE STATE MAY REJECT THE BID OR ACT AGAINST ME IN TERMS OF PARAGRAPH 6 OF PFMA SCM INSTRUCTION 03 OF 2021/22 ON PREVENTING AND COMBATING ABUSE IN THE SUPPLY CHAIN MANAGEMENT SYSTEM SHOULD THIS DECLARATION PROVE TO BE FALSE.

Signature

Date.....

Position.....

Name of bidder.....

ANNEXURE G - SBD 6.1

PREFERENCE POINTS CLAIM FORM IN TERMS OF THE PREFERENTIAL PROCUREMENT REGULATIONS 2022

This preference form must form part of all tenders invited. It contains general information and serves as a claim form for preference points for specific goals.

NB: BEFORE COMPLETING THIS FORM, TENDERERS MUST STUDY THE GENERAL CONDITIONS, DEFINITIONS AND DIRECTIVES APPLICABLE IN RESPECT OF THE TENDER AND PREFERENTIAL PROCUREMENT REGULATIONS, 2022.

1. GENERAL CONDITIONS

1.1 The following preference point systems are applicable to invitations to tender:

- the 80/20 system for requirements with a Rand value of up to R50 000 000 (all applicable taxes included); and
- the 90/10 system for requirements with a Rand value above R50 000 000 (all applicable taxes included).

1.2 To be completed by the organ of state. *(delete whichever is not applicable for this tender).*

- a) The applicable preference point system for this tender is the **90/10** preference point system.
- b) The applicable preference point system for this tender is the **80/20** preference point system.
- c) Either the **90/10 or 80/20** preference point system will be applicable in this tender. The lowest/ highest acceptable tender will be used to determine the accurate system once tenders are received.

1.3 Points for this tender (even in the case of a tender for income-generating contracts) shall be awarded for:

- (a) Price; and
- (b) Specific Goals.

To be completed by the organ of state:

The maximum points for this tender are allocated as follows:

	POINTS
PRICE	80
SPECIFIC GOALS	20
Total points for Price and Specific Goals	100

- 1.4. Failure on the part of a tenderer to submit proof or documentation required in terms of this tender to claim points for specific goals with the tender, will be interpreted to mean that preference points for specific goals are not claimed.
- 1.5. The organ of state reserves the right to require of a tenderer, either before a tender is adjudicated or at any time subsequently, to substantiate any claim in regard to preferences, in any manner required by the organ of state.

2. DEFINITIONS

- (a) **“tender”** means a written offer in the form determined by an organ of state in response to an invitation to provide goods or services through price quotations, competitive tendering process or any other method envisaged in legislation;
- (b) **“price”** means an amount of money tendered for goods or services, and includes all applicable taxes less all unconditional discounts;
- (c) **“rand value”** means the total estimated value of a contract in Rand, calculated at the time of bid invitation, and includes all applicable taxes;
- (d) **“tender for income-generating contracts”** means a written offer in the form determined by an organ of state in response to an invitation for the origination of income-generating contracts through any method envisaged in legislation that will result in a legal agreement between the organ of state and a third party that produces revenue for the organ of state, and includes, but is not limited to, leasing and disposal of assets and concession contracts, excluding direct sales and disposal of assets through public auctions; and
- (e) **“the Act”** means the Preferential Procurement Policy Framework Act, 2000 (Act No. 5 of 2000).

3. FORMULAE FOR PROCUREMENT OF GOODS AND SERVICES

3.1. POINTS AWARDED FOR PRICE

3.1.1 THE 80/20 OR 90/10 PREFERENCE POINT SYSTEMS

A maximum of 80 or 90 points is allocated for price on the following basis:

80/20 or 90/10

$$P_s = 80 \left(1 - \frac{P_t - P_{min}}{P_{min}} \right) \quad \text{or} \quad P_s = 90 \left(1 - \frac{P_t - P_{min}}{P_{min}} \right)$$

Where

P_s = Points scored for price of tender under consideration

P_t = Price of tender under consideration

P_{min} = Price of lowest acceptable tender

3.2. FORMULAE FOR DISPOSAL OR LEASING OF STATE ASSETS AND INCOME-GENERATING PROCUREMENT.

3.2.1. POINTS AWARDED FOR PRICE

A maximum of 80 or 90 points is allocated for price on the following basis:

80/20 or **90/10**

$$P_s = 80 \left(1 + \frac{P_t - P_{max}}{P_{max}} \right) \quad \text{or} \quad P_s = 90 \left(1 + \frac{P_t - P_{max}}{P_{max}} \right)$$

Where

P_s = Points scored for price of tender under consideration

P_t = Price of tender under consideration

P_{max} = Price of highest acceptable tender

4. POINTS AWARDED FOR SPECIFIC GOALS

4.1. In terms of Regulation 4(2); 5(2); 6(2) and 7(2) of the Preferential Procurement Regulations, preference points must be awarded for specific goals stated in the tender. For the purposes of this tender the tenderer will be allocated points based on the goals stated in table 1 below as may be supported by proof/ documentation stated in the conditions of this tender:

4.2. In cases where organs of state intend to use Regulation 3(2) of the Regulations, which states that, if it is unclear whether the 80/20 or 90/10 preference point system applies, an organ of state must, in the tender documents, stipulate in the case of—

(a) an invitation for tender for income-generating contracts, that either the 80/20 or 90/10 preference point system will apply and that the highest acceptable tender will be used to determine the applicable preference point system; or

(b) any other invitation for tender, that either the 80/20 or 90/10 preference point system

will apply and that the lowest acceptable tender will be used to determine the applicable preference point system, then the organ of state must indicate the points allocated for specific goals for both the 90/10 and 80/20 preference point system.

Table 1: Specific goals for the tender and points claimed are indicated per the table below.

(Note to organs of state: Where either the 90/10 or 80/20 preference point system is applicable, corresponding points must also be indicated as such.

Note to tenderers: The tenderer must indicate how they claim points for each preference point system).

The specific goals allocated points in terms of this tender	Number of points allocated (80/20 system) (To be completed by the organ of state)	Number of points claimed (80/20 system) (To be completed by the tenderer)
Black Owned Entity	6	
Women Owned Entity	4	
Youth Equity Ownership	4	
People With Disability	3	
Military Veterans	3	

DECLARATION WITH REGARD TO COMPANY/FIRM

4.3. Name of company/firm.....

4.4. Company registration number:

4.5. TYPE OF COMPANY/ FIRM

- Partnership/Joint Venture / Consortium
- One-person business/sole propriety
- Close corporation
- Public Company
- Personal Liability Company
- (Pty) Limited
- Non-Profit Company
- State Owned Company

[TICK APPLICABLE BOX]

4.6. I, the undersigned, who is duly authorised to do so on behalf of the company/firm,

certify that the points claimed, based on the specific goals as advised in the tender, qualifies the company/ firm for the preference(s) shown and I acknowledge that:

- i) The information furnished is true and correct;
- ii) The preference points claimed are in accordance with the General Conditions as indicated in paragraph 1 of this form;
- iii) In the event of a contract being awarded as a result of points claimed as shown in paragraphs 1.4 and 4.2, the contractor may be required to furnish documentary proof to the satisfaction of the organ of state that the claims are correct;
- iv) If the specific goals have been claimed or obtained on a fraudulent basis or any of the conditions of contract have not been fulfilled, the organ of state may, in addition to any other remedy it may have –
 - (a) disqualify the person from the tendering process;
 - (b) recover costs, losses or damages it has incurred or suffered as a result of that person's conduct;
 - (c) cancel the contract and claim any damages which it has suffered as a result of having to make less favourable arrangements due to such cancellation;
 - (d) recommend that the tenderer or contractor, its shareholders and directors, or only the shareholders and directors who acted on a fraudulent basis, be restricted from obtaining business from any organ of state for a period not exceeding 10 years, after the *audi alteram partem* (hear the other side) rule has been applied; and
 - (e) forward the matter for criminal prosecution, if deemed necessary.

..... SIGNATURE(S) OF TENDERER(S)	
SURNAME AND NAME:
DATE:
ADDRESS:

ANNEXURE I: SPECIFICATION

1. BACKGROUND

Broadband Infraco as a licensed service provider has deployed 412 Broadband service in OR Tambo District Municipality in the Eastern Cape Province and Pixley ka Seme in the Northern Cape Province through contract with Universal Services and Access Agency South Africa (USAASA). The partnership with USAASA has extended to the deployment of 200 Broadband service in Nyandeni Local Municipality in the Eastern Cape Province and in Harry Gwala District Municipality in KwaZulu Natal.

USAASA Phase 3 (332) is a further extension of the USSASA project in the Dr. Ruth Segomotsi Mompati district and 8 special schools. Due to the limited, and unreliable power supply from Eskom and various local municipalities, resulting in regular downtime of WiFi connectivity at facilities where USAASA is responsible for provisioning and maintaining internet connectivity.

2. OBJECTIVE

With the provisioning of a suitable UPS solution, it will result a higher quality, higher stable and reliable WiFi connectivity at these facilities where internet connectivity has been provisioned under the USAASA project This is part of project delivery for USAASA Phase 3. Successful implementation of this project can lead to more revenue and business opportunities to Broadband Infraco.

3. SCOPE OF WORK

Appointment of a panel of Service providers for the supply, delivery and installation of a UPS system with a solar and battery backup system for the below 340 sites:

Table 5

Item	Municipality	No of Sites
1	Dr Ruth Segomotsi Mompati District	332
2	Special Schools/facilities*	8
Total		340

Table 6: Special Schools

PROVINCE	School Name	Coordinates		Area	Disability category
Eastern Cape	Vukuzenzele	29°47'40.5"E	30°50'51.5"S	Nomlacu village, Bizana	Physical disability
	Zandiswa Kilwa library (Multipurpose Centre)	-31.8340450	28.0616220	Debera location	Physical disability
Free State	Tswelang Special School	-29.15599" S	26.25308" E	C/O Belcher and Monapi Street, Bloemfontein	Physical Disability
Northern Cape	Boitumelo special school	28°42'58.4"S	24°42'07.4"E	John Daka Street, Phuthanang township, Mankurwane, Kimberley	Intellectual Disability
Mpumalanga	Osizweni special school	28.91928	-26.3743	Govan Mbeki Local Municipality,	Speech, physical & mental
Limpopo	Fulufhelo special school			Block G, Thohoyandou, Phundamaria road (R524). Next to Phangami	Various disabilities
Gauteng	Thembinkosi Special school	-25.9907320	28.2315580	582 Makhulong street, Thembisa	Autism
North West	Reatlegile special school	-26.0803270	25.8846140	Itsoseng, Unit 3, Itsoseng	Autism

4. Overview of requested UPS solution

- The UPS to be deployed shall have a solar power incorporated and shall be a compliment to normal available AC grid power (and is not engineered for an off-grid solution)
- The UPS shall consist of an AC input, Solar input, Lithium Iron Phosphate (LiFePO4) battery, DC- Output with an associated input surge protection plug/built in surge protection.
- AC Input: The UPS shall be able to operate and recharge the internal battery from a normal utility plug.
- Solar Input: The UPS shall be able to be recharged the internal battery by the solar panels.
- The UPS to be deployed must support pass-through charging (being charged and discharged simultaneously). The UPS function shall have a response time of maximum 30 milliseconds for a seamless power transition between available power (either grid and/or solar), and battery power and vice versa.
- Solar panel shall be provided with a suitable adjustable angle pole mounted bracket (some facilities may require a new pole and/or a pole mounting

bracket). The bracket is to be made of galvanised steel and shall be included in the solution (installed facing North) and shall be able to supply power to the equipment and shall still have enough excess power to charge the battery.

- Solar panels shall be protected in all cases with a secured safety grid (i.e barbed-wire and/or lockable mesh) for protection against theft and vandalism.
- Battery: The included battery should be replaceable and should be of a Lithium Iron Phosphate (LiFePO4) type battery.
- A controller/regulator shall be supplied with the system, which shall have build-in battery management and onboard display/alarms.
- A system should be provided with a suitable wall mounted cabinet to house the CPE router, battery, controller and all protection for the system.
- Certifications: The UPS shall comply with the following minimum standards: CE mark (or equivalent and all other safety and legislation requirements (SANS IEC 60950). All wiring and installations to be compliant with SANS - 10142-1.

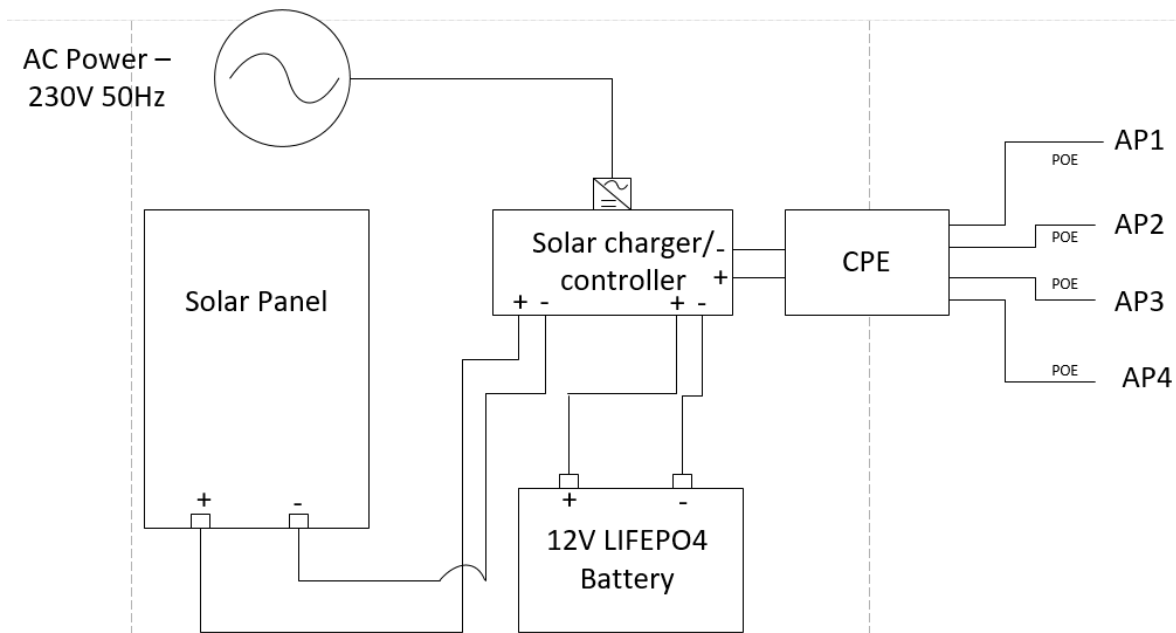

UPS solution with typical components and connections

Typical deployment and typical power consumption per site will be as follows:

Scenario 1

Equipment	Estimated Power consumption per unit	Number being deployed	Total Power Consumption
Huawei NetEngine AR651W-8P CPE	26 Watts	1	26 Watts (without any POE devices connected)
Huawei AirEngine 5762-12 (Indoor AP)	11 Watts	1	11 Watts (for 2 unit) - POE

Huawei AirEngine 5761R-11E (Outdoor AP)	20 Watts	1	20Watts-POE
		Total Power consumption per site	≈ 57 Watts

Scenario 2

Equipment	Estimated Power consumption per unit	Number being deployed	Total Power Consumption
Huawei NetEngine AR651W-8P CPE	26 Watts	1	26 Watts (without any POE devices connected)
Huawei AirEngine 5762-12 (Indoor AP)	11 Watts	2	11 Watts (for 2 unit) - POE
Huawei AirEngine 5761R-11E (Outdoor AP)	20 Watts	1	20Watts-POE
		Total Power consumption per site	≈ 68 Watts

Scenario 3

Equipment	Estimated Power consumption per unit	Number being deployed	Total Power Consumption
Huawei NetEngine AR651W-8P CPE	26 Watts	1	26 Watts (without any POE devices connected)
Huawei AirEngine 5762-12 (Indoor AP)	11 Watts	3	33 Watts (for 3 units) -POE
Huawei AirEngine 5761R-11E (Outdoor AP)	20 Watts	1	20Watts-POE
		Total Power consumption per site	≈ 79 Watts

Scenario 4

Equipment	Estimated Power consumption per unit	Number being deployed	Total Power Consumption
Huawei NetEngine AR651W-8P CPE	26 Watts	1	26 Watts (without any POE devices connected)
Huawei AirEngine 5762-12 (Indoor AP)	11 Watts	3	33 Watts (for 2 unit) - POE
Huawei AirEngine 5761R-11E (Outdoor AP)	20 Watts	1	20Watts-POE
VOIP phones*	4 Watts	3	12 Watts
		Total Power consumption per site	≈ 91 Watts

Some facilities may consume more power solution and may require a customised solution and it may be negotiated with the successful bidder.

* VOIP phones will be installed at various schools. Each school will have 3 x VOIP phones and it is estimated to draw about 4W each (Specific VOIP phone to be used still to be finalised)

The UPS/Solar back up system shall have the following minimum components and ratings:

- a. 1 x Tier 1 Monocrystalline solar panel (may consist of more than 1 solar panel in parallel as well) with a 12-year warranty. The installed solar power solution should be able to fully charge a fully depleted battery in typical 8 hours. Rating of solar panel should be a minimum 150Watts and it is preferred to use at least ≥ 200 Watt for scenario 1 and 2 and ≥ 250 W for scenario 3 and 4 sites;). The solar regulator should be rated for at least 300W minimum to cater for load and battery charging and be compatible with the proposed solar panel solution. (Brochure is to be supplied)
- b. The system should include a suitable replaceable battery and shall be of a Lithium Iron Phosphate (LiFePO₄) type. The supplied battery should have a 3-year warranty and a cycle capability of ≥ 2000 cycles with 80% depth of discharge. Battery storage required should be typical 8 hours and the rating/sizing of the battery should be minimum 12V 50Ah LiFePO₄ battery. It is preferred to use 12V 50Ah LiFePO₄ battery for scenario 1 and 2 and >12 V 75Ah LiFePO₄ battery for scenario 3 and 4; (Brochure is to be supplied).
- c. AC connection: Recharge of the battery should be able to be fully charged a fully depleted battery in typical 4 hours from the AC grid. The AC/DC converter should be rated for at least 300W minimum output to cater for load and battery charging
- d. Required controller (Brochure is to be supplied):
 1. Output Voltage Range to be typical 12V – 14.5V DC;
 2. Input voltage range should be for AC: AC Voltage of 230V+/- 10% 50Hz).
 3. Input range from Solar panel/s: To be compatible with the proposed solar panel solution's current and voltage as a minimum;
 4. Controller should have an MPPT tracker for the solar panel
 5. An onboard display should indicate the status on the system (input and output), battery status and any alarms on the system.
 6. The controller to be included to have build-in Intelligent charging algorithm and battery management system for charging the battery and powering the equipment
 7. Safety features not limited to over-charge, over-discharge, over temperature and short circuit protection; and
 8. Controller should have capability of real time reporting and viewing of the facility's status including solar power generation, battery status, load consumption, and WiFi/Remote connectivity; and
 9. Controller, protection and batteries shall be Installed in a suitable indoor wall mounted cabinet of minimum 12U. Efficient

air flow in the cabinet is required with vents at the side panels. Cabinet to be compliant to NE-NT-SP-0001. Cabinet to be power coated and lockable (no glass door allowed), earth bar installed and cable entries to be at the base with removable covers. (Picture and or proposal to be provided)

Typical solution to look as follows:



Bidders are required to bid on all 4 systems/scenarios as per above Scope of Work. (The same solution may be offered on multiple scenarios).

Note: BBI may decide, depending on the technical and commercial proposal on the different requested scenarios, to possibly to use an offered proposal on a specific scenario also on different/other scenarios as well.

ANNEXURE J: PRICING SCHEDULE

ITEM	Description	Quantity	Unit Price	Total Price
1	Scenario 1 with total Power \approx 57 Watts	85		
2	Scenario 2 with total Power \approx 68 Watts	85		
3	Scenario 3 with total Power \approx 79 Watts	85		
4	Scenario 4 with total Power \approx 91 Watts	85		
Price Excl. VAT				
VAT @15%				
Total Incl. VAT				

Note the total number of facilities/schools per each scenario is still to be finalised. For pricing purposes equal spread of facilities per scenario has been indicated as per above table

ANNEXURE K – RECEIPT OF THE INVITATION FORM

To: Broadband Infraco SOC Limited From: Name of the firm_____

Sentech Technology Park Email: _____

2040 Octave Street Tel: _____

Attention: _____

REQUEST FOR PROPOSAL: INF/TEN: 337: INVITATION TO SUBMIT PROPOSALS FOR THE APPOINTMENT OF A PANEL OF SERVICE PROVIDERS FOR THE SUPPLY, DELIVERY AND INSTALLATION OF A UPS SYSTEM WITH A SOLAR AND BATTERY BACKUP FOR 340 BROADBAND INFRACO SITES.

CLOSING DATE: 30 OCTOBER 2024 @ 12h00 noon (RSA TIME)

1 We have noted the *deadline for the RFP submission* and will be submitting our quotation before then and as instructed. We propose to submit a quotation in the name of the firm stated above.

2 We do not intend to submit a response for this service and return all of the attached documentation herewith. Our reason for not wishing to submit a quotation is as follows:

Nota Bene (NB)*

- This form must be sent back to Broadband Infraco’s contact by the deadline of question responses – **28 October 2024** to allow Broadband to send responses and for individual bidders to prepare the responses so as the closing date cannot be affected by late questions and responses.
- Submission of this form will help Broadband Infraco compile a list of interested bidders who will be directly contactable when there are scope changes, addendums and/or for any formal communication for tender **INF/TEN: 337**

Yours Faithfully

Bidders Name:_____

Date: _____