



NEC3 Engineering & Construction Contract

Between **ESKOM HOLDINGS SOC Ltd**
(Reg No. 2002/015527/30)

and
(Reg No. _____)

for The Request for Proposal and Subsequent award of a contract for a Turn-key project for the Design, Supply and installation of Solar Photovoltaic (PV), Inverter and Battery Energy Storage System (BESS) and Post Installation Maintenance for a period of 24 months for St Joseph's Solar System House Project in KZN Operating Unit.

Contents:	No of pages
Part C1 Agreements & Contract Data	[•]
Part C2 Pricing Data	[•]
Part C3 Scope of Work	[•]
Part C4 Site Information	[•]

CONTRACT No.

Part C1: Agreements & Contract Data

Contents:	No of pages
C1.1 Form of Offer and Acceptance	[•]
C1.2a Contract Data provided by the <i>Employer</i>	[•]
C1.2b Contract Data provided by the <i>Contractor</i>	[•]
C1.3 Proforma Guarantees	[•]

C1.1 Form of Offer & Acceptance

Offer

The Employer, identified in the Acceptance signature block, has solicited offers to enter into a contract for the procurement of:

The Request for Proposal and Subsequent award of a contract for a Turn-key project for the Design, Supply and installation of Solar Photovoltaic (PV), Inverter and Battery Energy Storage System (BESS) and Post Installation Maintenance for a period of 24 months for St Joseph's Solar System House Project in KZN Operating Unit.

The tenderer, identified in the Offer signature block, has examined the documents listed in the Tender Data and addenda thereto and by submitting this Offer has accepted the Conditions of Tender.

By the representative of the tenderer, deemed to be duly authorised, signing this part of this Form of Offer and Acceptance the tenderer offers to perform all of the obligations and liabilities of the *Contractor* under the contract including compliance with all its terms and conditions according to their true intent and meaning for an amount to be determined in accordance with the *conditions of contract* identified in the Contract Data.

Option A	The offered total of the Prices exclusive of VAT is	
	Sub total	
	Value Added Tax @ 15% is	
	The offered total of the amount due inclusive of VAT is ¹	

This Offer may be accepted by the Employer by signing the Acceptance part of this Form of Offer and Acceptance and returning one copy of this document including the Schedule of Deviations (if any) to the tenderer before the end of the period of validity stated in the Tender Data, or other period as agreed, whereupon the tenderer becomes the party named as the *Contractor* in the *conditions of contract* identified in the Contract Data.

Signature(s)

Name(s) _____

Capacity _____

For the tenderer:

(Insert name and address of organisation)

Name & signature of witness

Date

Tenderer's CIDB registration number (if applicable)

¹ This total is required by the *Employer* for budgeting purposes only. Actual amounts due will be assessed in terms of the *conditions of contract*.

Acceptance

By signing this part of this Form of Offer and Acceptance, the Employer identified below accepts the tenderer's Offer. In consideration thereof, the Employer shall pay the Contractor the amount due in accordance with the *conditions of contract* identified in the Contract Data. Acceptance of the tenderer's Offer shall form an agreement between the Employer and the tenderer upon the terms and conditions contained in this agreement and in the contract that is the subject of this agreement.

The terms of the contract, are contained in:

Part C1	Agreements and Contract Data, (which includes this Form of Offer and Acceptance)
Part C2	Pricing Data
Part C3	Scope of Work: Works Information
Part C4	Site Information

and drawings and documents (or parts thereof), which may be incorporated by reference into the above listed Parts.

Deviations from and amendments to the documents listed in the Tender Data and any addenda thereto listed in the Returnable Schedules as well as any changes to the terms of the Offer agreed by the tenderer and the Employer during this process of offer and acceptance, are contained in the Schedule of Deviations attached to and forming part of this Form of Offer and Acceptance. No amendments to or deviations from said documents are valid unless contained in this Schedule.

The tenderer shall within two weeks of receiving a completed copy of this agreement, including the Schedule of Deviations (if any), contact the Employer's agent (whose details are given in the Contract Data) to arrange the delivery of any securities, bonds, guarantees, proof of insurance and any other documentation to be provided in terms of the *conditions of contract* identified in the Contract Data at, or just after, the date this agreement comes into effect. Failure to fulfil any of these obligations in accordance with those terms shall constitute a repudiation of this agreement.

Notwithstanding anything contained herein, this agreement comes into effect on the date when the tenderer receives one fully completed original copy signed between them of this document, including the Schedule of Deviations (if any).

Unless the tenderer (now *Contractor*) within five working days of the date of such receipt notifies the Employer in writing of any reason why he cannot accept the contents of this agreement, this agreement shall constitute a binding contract between the Parties.

Signature(s)

Name(s)

Zetu Nciza

Capacity

Acting Senior Manager Asset Creation
- Central Easter Cluster

**for the
Employer**

ESKOM HOLDING SOC LIMITED

25 Valley View Road, New Germany, 3602

Name &
signature of
witness

Date

Note: If a tenderer wishes to submit alternative tenders, use another copy of this Form of Offer and Acceptance.

Schedule of Deviations to be completed by the Employer prior to contract award

Note:

1. This part of the Offer & Acceptance would not be required if the contract has been developed by negotiation between the Parties and is not the result of a process of competitive tendering.
2. The extent of deviations from the tender documents issued by the Employer prior to the tender closing date is limited to those permitted in terms of the Conditions of Tender.
3. A tenderer's covering letter must not be included in the final contract document. Should any matter in such letter, which constitutes a deviation as aforesaid be the subject of agreement reached during the process of Offer and Acceptance, the outcome of such agreement shall be recorded here and the final draft of the contract documents shall be revised to incorporate the effect of it.

No.	Subject	Details
1	[•]	[•]
2	[•]	[•]
3	[•]	[•]
4	[•]	[•]
5	[•]	[•]
6	[•]	[•]
7	[•]	[•]

By the duly authorised representatives signing this Schedule of Deviations below, the Employer and the tenderer agree to and accept this Schedule of Deviations as the only deviations from and amendments to the documents listed in the Tender Data and any addenda thereto listed in the Tender Schedules, as well as any confirmation, clarification or changes to the terms of the Offer agreed by the tenderer and the Employer during this process of Offer and Acceptance.

It is expressly agreed that no other matter whether in writing, oral communication or implied during the period between the issue of the tender documents and the receipt by the tenderer of a completed signed copy of this Form shall have any meaning or effect in the contract between the parties arising from this Agreement.

For the tenderer:

For the Employer

Signature _____

Name _____

Zetu Nciza

Capacity _____

Acting Senior Manager Asset Creation - (CEC)

On behalf of *(Insert name and address of organisation)* _____

25 Valley View Road, New Germany, 3602

Name & signature of witness _____

Date _____

C1.2 ECC3 Contract Data

Part one - Data provided by the *Employer*

Clause	Statement	Data
1	General	
	The <i>conditions of contract</i> are the core clauses and the clauses for main Option	
	dispute resolution Option and secondary Options	A: Priced contract with activity schedule W1: Dispute resolution procedure X1: Price adjustment for inflation X2 Changes in the law X7: Delay damages X13: Performance Bond (Provisional) X16: Retention X18: Limitation of liability
	of the NEC3 Engineering and Construction Contract, April 2013 (ECC3)	Z: Additional conditions of contract
10.1	The <i>Employer</i> is (Name):	Eskom Holdings SOC Ltd (reg no: 2002/015527/30), a state owned company incorporated in terms of the company laws of the Republic of South Africa
	Address	Registered office at Megawatt Park, Maxwell Drive, Sandton, Johannesburg
10.1	The <i>Project Manager</i> is: (Name)	Mlungisi Sibiya
	Address	3 Menston Road Westville
	Tel	031 240 7996
	Fax	Not Applicable
	e-mail	sibiyaml@eskom.co.za
11.2(13)	The <i>works</i> are	Design, Supply, Installation and Post Installation Maintenance for St Joseph's Solar System House Project

11.2(14)	The following matters will be included in the Risk Register	As per the SHE Specification <ul style="list-style-type: none"> • Site access • Design alterations • Safety compliance • Theft and vandalism • Community unrest • Weather 	
11.2(15)	The <i>boundaries of the site</i> are	St Joseph's Site	
11.2(16)	The Site Information is in	Part 4: Site Information	
11.2(19)	The Works Information is in	Part 3: Scope of Work and all documents and drawings to which it makes reference.	
12.2	The <i>law of the contract</i> is the law of	the Republic of South Africa	
13.1	The <i>language of this contract</i> is	English	
13.3	The <i>period for reply</i> is	2 weeks	
2	The Contractor's main responsibilities	Data required by this section of the core clauses is provided by the <i>Contractor</i> in Part 2 and terms in italics used in this section are identified elsewhere in this Contract Data.	
3	Time		
11.2(3)	The <i>completion date</i> for the whole of the works is	31 March 2027 – for Design, Installation & Project Close Out 31 May 2029 – for Maintenance	
11.2(9)	The <i>key dates</i> and the <i>conditions</i> to be met are:	Condition to be met 31 March 2027 – for Design, Installation & Project Close Out 31 March 2029 – for Maintenance	
30.1	The <i>access dates</i> are:	Part of the Site Access dates will be specified in the Project Agreement	As per the access to site certificate signed by the PM
31.1	The <i>Contractor</i> is to submit a first programme for acceptance within	1 weeks after kick-off meeting	

31.2	The <i>starting date</i> is	01 September 2026
------	-----------------------------	--------------------------

32.2	The <i>Contractor</i> submits revised programmes at intervals no longer than	1 week.
------	--	----------------

35.1	The <i>Employer</i> is not willing to take over the <i>works</i> before the Completion Date.	
------	--	--

4 Testing and Defects

42.2	The <i>defects date</i> is	52 weeks after Completion of the installation of the works.
------	----------------------------	--

43.2	The <i>defect correction period</i> is	2 weeks
------	--	----------------

5 Payment

50.1	The <i>assessment interval</i> is	between the 25th day of each successive month.
------	-----------------------------------	--

51.1	The <i>currency of this contract</i> is the	South African Rand.
------	---	----------------------------

51.2	The period within which payments are made is	14 or 30 days (depending on the BBEE status of the Contractor) on approval of the claim.
------	--	---

51.4	The <i>interest rate</i> is	the publicly quoted prime rate of interest (calculated on a 365 day year) charged from time to time by the Standard Bank of South Africa Limited (as certified, in the event of any dispute, by any manager of such bank, whose appointment it shall not be necessary to prove) for amounts due in Rands and
------	-----------------------------	---

(ii) the LIBOR rate applicable at the time for amounts due in other currencies. LIBOR is the 6 month London Interbank Offered Rate quoted under the caption "Money Rates" in The Wall Street Journal for the applicable currency or if no rate is quoted for the currency in question then the rate for United States Dollars, and if no such rate appears in The Wall Street Journal then the rate as quoted by the Reuters Monitor Money Rates Service (or such service as may replace the Reuters Monitor Money Rates Service) on the due date for the payment in question, adjusted *mutatis mutandis* every 6 months thereafter and as certified, in the event of any dispute, by any manager employed in the foreign exchange department of The Standard Bank of South Africa Limited, whose appointment it shall not be necessary to prove.

6	Compensation events	
60.1(13)	The place where weather is to be recorded is:	St Joseph's Site
	The <i>weather measurements</i> to be recorded for each calendar month are,	<p>the cumulative rainfall (mm)</p> <p>the number of days with rainfall more than 10 mm</p> <p>the number of days with minimum air temperature less than 0 degrees Celsius</p> <p>the number of days with snow lying at 09:00 hours South African Time</p> <p>and these measurements:</p>
	The <i>weather measurements</i> are supplied by	The Contractor
	The <i>weather data</i> are the records of past <i>weather measurements</i> for each calendar month which were recorded at:	Nearest weather station of the South African Weather Services closer to site
	and which are available from:	the South African Weather Bureau and included in Annexure A to this Contract Data provided by the <i>Employer</i>
7	Title	There is no reference to Contract Data in this section of the core clauses and terms in italics used in this section are identified elsewhere in this Contract Data.
8	Risks and insurance	There is no reference to Contract Data in this section of the core clauses and terms in italics used in this section are identified elsewhere in this Contract Data.
9	Termination	There is no reference to Contract Data in this section of the core clauses and terms in italics used in this section are identified elsewhere in this Contract Data.
10	Data for main Option clause	
A	Priced contract with activity schedule	There is no reference to Contract Data in this Option and terms in italics are identified elsewhere in this Contract Data.
11	Data for Option W1	
W1.1	The <i>Adjudicator</i> is	the person selected from the ICE-SA Division (or its successor body) of the South African Institution of Civil Engineering Panel of Adjudicators by the Party intending to refer a dispute to him. (see www.ice-sa.org.za). If the Parties do not agree on an Adjudicator the Adjudicator will be appointed by the Arbitration Foundation of Southern Africa (AFSA).

W1.2(3)	The <i>Adjudicator nominating body</i> is:	the Chairman of ICE-SA a joint Division of the South African Institution of Civil Engineering and the London Institution of Civil Engineers. (See www.ice-sa.org.za) or its successor body.
W1.4(2)	The <i>tribunal</i> is:	arbitration.
W1.4(5)	The <i>arbitration procedure</i> is	the latest edition of Rules for the Conduct of Arbitrations published by The Association of Arbitrators (Southern Africa) or its successor body.
	The place where arbitration is to be held is	KwaZulu-Natal, South Africa
	The person or organisation who will choose an arbitrator - if the Parties cannot agree a choice or if the arbitration procedure does not state who selects an arbitrator, is	the Chairman for the time being or his nominee of the Association of Arbitrators (Southern Africa) or its successor body.
12	Data for secondary Option clauses	
X2	Changes in the law	There is no reference to Contract Data in this Option and terms in italics are identified elsewhere in this Contract Data.
X7	Delay damages (but not if Option X5 is also used)	
X7.1	Delay damages for Completion of the whole of the <i>works</i> are	R2000 per day up to a limit of 10% of the estimated tendered sum
X13	Performance bond	
X13.1	The amount of the performance bond is	
X16	Retention (not used with Option F)	
X16.1	The <i>retention free amount</i> is	The value of the maintenance cost
	The <i>retention percentage</i> is	10%
X18	Limitation of liability	
X18.1	The <i>Contractor's</i> liability to the <i>Employer</i> for indirect or consequential loss is limited to:	R0.0 (zero Rand)
X18.2	For any one event, the <i>Contractor's</i> liability to the <i>Employer</i> for loss of or damage to the <i>Employer's</i> property is limited to:	the amount of the deductibles relevant to the event
X18.3	The <i>Contractor's</i> liability for Defects due to his design which are not listed on the Defects Certificate is limited to	The greater of • the total of the Prices at the Contract Date and the amounts excluded and unrecoverable from the <i>Employer's</i> assets policy for correcting the Defect (other than the resulting physical damage which is not excluded) plus the

		applicable deductible as at contract date.
X18.4	The <i>Contractor's</i> total liability to the <i>Employer</i> for all matters arising under or in connection with this contract, other than excluded matters, is limited to:	<p>the total of the Prices other than for the additional excluded matters.</p> <p>The <i>Contractor's</i> total liability for the additional excluded matters is not limited.</p> <p>The additional excluded matters are amounts for which the <i>Contractor</i> is liable under this contract for</p> <ul style="list-style-type: none"> • Defects due to his design which arise before the Defects Certificate is issued, • Defects due to manufacture and fabrication outside the Site, • loss of or damage to property (other than the <i>works</i>, Plant and Materials), • death of or injury to a person and infringement of an intellectual property right.
X18.5	The <i>end of liability date</i> is	<p>(i) Seven (7) years after the <i>defects date</i> for latent Defects and</p> <p>(ii) the date on which the liability in question prescribes in accordance with the Prescription Act No. 68 of 1969 (as amended or in terms of any replacement legislation) for any other matter.</p> <p>A latent Defect is a Defect which would not have been discovered on reasonable inspection by the <i>Employer</i> or the <i>Supervisor</i> before the <i>defects date</i>, without requiring any inspection not ordinarily carried out by the <i>Employer</i> or the <i>Supervisor</i> during that period. If the <i>Employer</i> or the <i>Supervisor</i> do undertake any inspection over and above the reasonable inspection, this does not place a greater responsibility on the <i>Employer</i> or the <i>Supervisor</i> to have discovered the Defect.</p>
Z	The <i>Additional conditions of contract</i> are	Z1 to Z15 always apply.
Z1	Cession delegation and assignment	
Z1.1	The <i>Contractor</i> does not cede, delegate or assign any of its rights or obligations to any person without the written consent of the <i>Employer</i> .	
Z1.2	Notwithstanding the above, the <i>Employer</i> may on written notice to the <i>Contractor</i> cede and delegate its rights and obligations under this contract to any of its subsidiaries or any of its present divisions or operations which may be converted into separate legal entities as a result of the restructuring of the Electricity Supply Industry.	

Z2 Joint ventures

- Z2.1 If the *Contractor* constitutes a joint venture, consortium or other unincorporated grouping of two or more persons or organisations then these persons or organisations are deemed to be jointly and severally liable to the *Employer* for the performance of this contract.
- Z2.2 Unless already notified to the *Employer*, the persons or organisations notify the *Project Manager* within two weeks of the Contract Date of the key person who has the authority to bind the *Contractor* on their behalf.
- Z2.3 The *Contractor* does not alter the composition of the joint venture, consortium or other unincorporated grouping of two or more persons without the consent of the *Employer* having been given to the *Contractor* in writing.

Z3 Change of Broad Based Black Economic Empowerment (B-BBEE) status

- Z3.1 Where a change in the *Contractor's* legal status, ownership or any other change to his business composition or business dealings results in a change to the *Contractor's* B-BBEE status, the *Contractor* notifies the *Employer* within seven days of the change.
- Z3.2 The *Contractor* is required to submit an updated verification certificate and necessary supporting documentation confirming the change in his B-BBEE status to the *Project Manager* within thirty days of the notification or as otherwise instructed by the *Project Manager*.
- Z3.3 Where, as a result, the *Contractor's* B-BBEE status has decreased since the Contract Date the *Employer* may either re-negotiate this contract or alternatively, terminate the *Contractor's* obligation to Provide the Works.
- Z3.4 Failure by the *Contractor* to notify the *Employer* of a change in its B-BBEE status may constitute a reason for termination. If the *Employer* terminates in terms of this clause, the procedures on termination are P1, P2 and P3 as stated in clause 92, and the amount due is A1 and A3 as stated in clause 93.

Z4 Confidentiality

- Z4.1 The *Contractor* does not disclose or make any information arising from or in connection with this contract available to Others. This undertaking does not, however, apply to information which at the time of disclosure or thereafter, without default on the part of the *Contractor*, enters the public domain or to information which was already in the possession of the *Contractor* at the time of disclosure (evidenced by written records in existence at that time). Should the *Contractor* disclose information to Others in terms of clause 25.1, the *Contractor* ensures that the provisions of this clause are complied with by the recipient.
- Z4.2 If the *Contractor* is uncertain about whether any such information is confidential, it is to be regarded as such until notified otherwise by the *Project Manager*.
- Z4.3 In the event that the *Contractor* is, at any time, required by law to disclose any such information which is required to be kept confidential, the *Contractor*, to the extent permitted by law prior to disclosure, notifies the *Employer* so that an appropriate protection order and/or any other action can be taken if possible, prior to any disclosure. In the event that such protective order is not, or cannot, be obtained, then the *Contractor* may disclose that portion of the information which it is required to be disclosed by law and uses reasonable efforts to obtain assurances that confidential treatment will be afforded to the information so disclosed.
- Z4.4 The taking of images (whether photographs, video footage or otherwise) of the *works* or any portion thereof, in the course of Providing the Works and after Completion, requires the prior written consent of the *Project Manager*. All rights in and to all such images vests exclusively in the *Employer*.

Z4.5 The *Contractor* ensures that all his subcontractors abide by the undertakings in this clause.

Z5 Waiver and estoppel: Add to core clause 12.3:

Z5.1 Any extension, concession, waiver or relaxation of any action stated in this contract by the Parties, the *Project Manager*, the *Supervisor*, or the *Adjudicator* does not constitute a waiver of rights, and does not give rise to an estoppel unless the Parties agree otherwise and confirm such agreement in writing.

Z6 Health, safety and the environment: Add to core clause 27.4

Z6.1 The *Contractor* undertakes to take all reasonable precautions to maintain the health and safety of persons in and about the execution of the *works*. Without limitation the *Contractor*:

- accepts that the *Employer* may appoint him as the "Principal Contractor" (as defined and provided for under the Construction Regulations 2014 (promulgated under the Occupational Health & Safety Act 85 of 1993) ("the Construction Regulations") for the Site;
- warrants that the total of the Prices as at the Contract Date includes a sufficient amount for proper compliance with the Construction Regulations, all applicable health & safety laws and regulations and the health and safety rules, guidelines and procedures provided for in this contract and generally for the proper maintenance of health & safety in and about the execution of *works*; and

undertakes, in and about the execution of the *works*, to comply with the Construction Regulations and with all applicable health & safety laws and regulations and rules, guidelines and procedures otherwise provided for under this contract and ensures that his Subcontractors, employees and others under the *Contractor's* direction and control, likewise observe and comply with the foregoing.

Z6.2 The *Contractor*, in and about the execution of the *works*, complies with all applicable environmental laws and regulations and rules, guidelines and procedures otherwise provided for under this contract and ensures that his Subcontractors, employees and others under the *Contractor's* direction and control, likewise observe and comply with the foregoing.

Z7 Provision of a Tax Invoice and interest. Add to core clause 51

Z7.1 Within one week of receiving a payment certificate from the *Project Manager* in terms of core clause 51.1, the *Contractor* provides the *Employer* with a tax invoice in accordance with the *Employer's* procedures stated in the Works Information, showing the amount due for payment equal to that stated in the payment certificate.

Z7.2 If the *Contractor* does not provide a tax invoice in the form and by the time required by this contract, the time by when the *Employer* is to make a payment is extended by a period equal in time to the delayed submission of the correct tax invoice. Interest due by the *Employer* in terms of core clause 51.2 is then calculated from the delayed date by when payment is to be made.

Z7.3 The *Contractor* (if registered in South Africa in terms of the companies Act) is required to comply with the requirements of the Value Added Tax Act, no 89 of 1991 (as amended) and to include the *Employer's* VAT number 4740101508 on each invoice he submits for payment.

Z8 Notifying compensation events

Z8.1 • Delete from the last sentence in core clause 61.3, "unless the *Project Manager* should have notified the event to the *Contractor* but did not".

Z9 Employer's limitation of liability

Z9.1 The *Employer's* liability to the *Contractor* for the *Contractor's* indirect or consequential loss is limited to R0.00 (zero Rand)

Z9.2 The *Contractor's* entitlement under the indemnity in 83.1 is provided for in 60.1(14) and the *Employer's* liability under the indemnity is limited.

Z10 Termination: Add to core clause 91.1, at the second main bullet point, fourth sub-bullet point, after the words "against it":

Z10.1 or had a business rescue order granted against it.

Z11 Addition to secondary Option X7 Delay damages (if applicable in this contract)

Z11.1 If the amount due for the *Contractor's* payment of delay damages reaches the limits stated in this Contract Data for Option X7 or Options X5 and X7 used together, the *Employer* may terminate the *Contractor's* obligation to Provide the Works using the same procedures and payment on termination as those applied for reasons R1 to R15 or R18 stated in the Termination Table.

Z12 Ethics

For the purposes of this Z-clause, the following definitions apply:

Affected Party means, as the context requires, any party, irrespective of whether it is the *Contractor* or a third party, such party's employees, agents, or Subcontractors or Subcontractor's employees, or any one or more of all of these parties' relatives or friends,

Coercive Action means to harm or threaten to harm, directly or indirectly, an Affected Party or the property of an Affected Party, or to otherwise influence or attempt to influence an Affected Party to act unlawfully or illegally,

Collusive Action means where two or more parties co-operate to achieve an unlawful or illegal purpose, including to influence an Affected Party to act unlawfully or illegally,

Committing Party means, as the context requires, the *Contractor*, or any member thereof in the case of a joint venture, or its employees, agents, or Subcontractor or the Subcontractor's employees,

Corrupt Action means the offering, giving, taking, or soliciting, directly or indirectly, of a good or service to unlawfully or illegally influence the actions of an Affected Party,

Fraudulent Action means any unlawfully or illegally intentional act or omission that misleads, or attempts to mislead, an Affected Party, in order to obtain a financial or other benefit or to avoid an obligation or incurring an obligation,

Obstructive Action means a Committing Party unlawfully or illegally destroying, falsifying, altering or concealing information or making false statements to materially impede an investigation into allegations of Prohibited Action, and

Prohibited Action means any one or more of a Coercive Action, Collusive Action Corrupt Action, Fraudulent Action or Obstructive Action.

Z12.1 A Committing Party may not take any Prohibited Action during the course of the procurement of this contract or in execution thereof.

Z12.2 The *Employer* may terminate the *Contractor's* obligation to Provide the Services if a Committing Party has taken such Prohibited Action and the *Contractor* did not take timely and appropriate action to prevent or remedy the situation, without limiting any other rights or remedies the *Employer* has. It is not required that the Committing Party had to have been found guilty, in court or in any other similar process, of such Prohibited Action before the *Employer* can terminate the *Contractor's* obligation to Provide the Services for this reason.

Z12.3 If the *Employer* terminates the *Contractor's* obligation to Provide the Services for this reason, the amounts due on termination are those intended in core clauses 92.1 and 92.2.

Z12.4 A Committing Party co-operates fully with any investigation pursuant to alleged Prohibited Action. Where the *Employer* does not have a contractual bond with the Committing Party, the *Contractor* ensures that the Committing Party co-operates fully with an investigation.

Z13 Insurance

Z 13.1 Replace core clause 84 with the following:

Insurance cover 84

84.1 When requested by a Party, the other Party provides certificates from his insurer or broker stating that the insurances required by this contract are in force.

84.2 The *Contractor* provides the insurances stated in the Insurance Table A.

84.3 The insurances provide cover for events which are at the *Contractor's* risk from the *starting date* until the earlier of Completion and the date of the termination certificate.

INSURANCE TABLE A

Insurance against	Minimum amount of cover or minimum limit of indemnity
Loss of or damage to the <i>works</i> , Plant and Materials	The replacement cost where not covered by the <i>Employer's</i> insurance The <i>Employer's</i> policy deductible, as Contract Date, where covered by the <i>Employer's</i> insurance
Loss of or damage to Equipment	The replacement cost
Liability for loss of or damage to property (except the <i>works</i> , Plant and Materials and Equipment) and liability for bodily injury to or death of a person (not an employee of the <i>Contractor</i>) caused by activity in connection with this contract	<u>Loss of or damage to property</u> <u>Employer's property</u> The replacement cost where not covered by the <i>Employer's</i> insurance The <i>Employer's</i> policy deductible, as Contract Date, where covered by the <i>Employer's</i> insurance <u>Other property</u> The replacement cost <u>Bodily injury to or death of a person</u> The amount required by applicable law
Liability for death of or bodily injury to employees of the <i>Contractor</i> arising out of and in the course of their employment in connection with this contract	The amount required by the applicable law

Z 13.2

Replace core clause 87 with the following:

The *Employer* provides the insurances stated in the Insurance Table B.

INSURANCE TABLE B

Insurance against or name of policy	Minimum amount of cover or minimum of indemnity
Assets All Risk	Per the insurance policy document
Contract Works insurance	Per the insurance policy document
Environmental Liability	Per the insurance policy document
General and Public Liability	Per the insurance policy document
Transportation (Marine)	Per the insurance policy document
Motor Fleet and Mobile Plant	Per the insurance policy document
Terrorism	Per the insurance policy document
Cyber Liability	Per the insurance policy document
Nuclear Material Damage and Business Interruption	Per the insurance policy document
Nuclear Material Damage Terrorism	Per the insurance policy document

Z14 Nuclear Liability

- Z14.1 The *Employer* is the operator of the Koeberg Nuclear Power Station (KNPS), a nuclear installation, as designated by the National Nuclear Regulator of the Republic of South Africa, and is the holder of a nuclear licence in respect of the KNPS.
- Z14.2 The *Employer* is solely responsible for and indemnifies the *Contractor* or any other person against any and all liabilities which the *Contractor* or any person may incur arising out of or resulting from nuclear damage, as defined in Act 47 of 1999, save to the extent that any liabilities are incurred due to the unlawful intent of the *Contractor* or any other person or the presence of the *Contractor* or that person or any property of the *Contractor* or such person at or in the KNPS or on the KNPS site, without the permission of the *Employer* or of a person acting on behalf of the *Employer*.
- Z14.3 Subject to clause Z14.4 below, the *Employer* waives all rights of recourse, arising from the aforesaid, save to the extent that any claims arise or liability is incurred due or attributable to the unlawful intent of the *Contractor* or any other person, or the presence of the *Contractor* or that person or any property of the *Contractor* or such person at or in the KNPS or on the KNPS site, without the permission of the *Employer* or of a person acting on behalf of the *Employer*.
- Z14.4 The *Employer* does not waive its rights provided for in section 30 (7) of Act 47 of 1999, or any replacement section dealing with the same subject matter.
- Z14.5 The protection afforded by the provisions hereof shall be in effect until the KNPS is decommissioned.

Z15 Asbestos

For the purposes of this Z-clause, the following definitions apply:

AAIA	means approved asbestos inspection authority.
ACM	means asbestos containing materials.
AL	means action level, i.e. a level of 50% of the OEL, i.e. 0.1 regulated asbestos fibres per ml of air measured over a 4 hour period. The value at which proactive actions is required in order to control asbestos exposure to prevent exceeding the OEL.
Ambient Air	means breathable air in area of work with specific reference to breathing zone, which is defined to be a virtual area within a radius of approximately 30cm from the nose inlet.
Compliance Monitoring	means compliance sampling used to assess whether or not the personal exposure of workers to regulated asbestos fibres is in compliance with the Standard's requirements for safe processing, handling, storing, disposal and phase-out of asbestos and asbestos containing material, equipment and articles.
OEL	means occupational exposure limit.
Parallel Measurements	means measurements performed in parallel, yet separately, to existing measurements to verify validity of results.
Safe Levels	means airborne asbestos exposure levels conforming to the Standard's requirements for safe processing, handling, storing, disposal and phase-out of asbestos and asbestos containing material, equipment and articles.
Standard	means the <i>Employer's</i> Asbestos Standard 32-303: Requirements for Safe Processing, Handling, Storing, Disposal and Phase-out of Asbestos and Asbestos Containing Material, Equipment and Articles.
SANAS	means the South African National Accreditation System.
TWA	means the average exposure, within a given workplace, to airborne asbestos fibres, normalised to the baseline of a 4 hour continuous period, also applicable to short term exposures, i.e. 10-minute TWA.

Z15.1 The *Employer* ensures that the *Ambient Air* in the area where the *Contractor* will Provide the Services conforms to the acceptable prescribed South African standard for asbestos, as per the regulations published in GNR 155 of 10 February 2002, under the Occupational Health and Safety Act, 1993 (Act 85 of 1993) ("Asbestos Regulations"). The OEL for asbestos is 0.2 regulated asbestos fibres per millilitre of air as a 4-hour TWA, averaged over any continuous period of four hours, and the short term exposure limit of 0.6 regulated asbestos fibres per millilitre of air as a 10-minute TWA, averaged over any 10 minutes, measured in accordance with HSG248 and monitored according to HSG173 and OESSM.

Z15.2 Upon written request by the *Contractor*, the *Employer* certifies that these conditions prevail. All measurements and reporting are effected by an independent, competent, and certified occupational hygiene inspection body, i.e. a SANAS accredited and Department of Employment and Labour approved AAIA. The *Contractor* may perform Parallel Measurements and related control measures at the *Contractor's* expense. For the purposes of compliance the results generated from Parallel Measurements are evaluated only against South African statutory limits as detailed in clause Z15.1. Control measures conform to the requirements stipulated in the AAIA-approved asbestos work plan.

- Z15.3 The *Employer* manages asbestos and ACM according to the Standard.
- Z15.4 In the event that any asbestos is identified while Providing the Services, a risk assessment is conducted and if so required, with reference to possible exposure to an airborne concentration of above the AL for asbestos, immediate control measures are implemented and relevant air monitoring conducted in order to declare the area safe.
- Z15.5 The *Contractor's* personnel are entitled to stop working and leave the contaminated area forthwith until such time that the area of concern is declared safe by either Compliance Monitoring or an AAIA approved control measure intervention, for example, per the emergency asbestos work plan, if applicable.
- Z15.6 The *Contractor* continues to Provide the Services, without additional control measures presented, on presentation of Safe Levels. The contractually agreed dates to Provide the Services, including the Completion Date, are adjusted accordingly. The contractually agreed dates are extended by the notification periods required by regulations 3 and 21 of the Asbestos Regulations, 2001.
- Z15.7 Any removal and disposal of asbestos, asbestos containing materials and waste, is done by a registered asbestos contractor, instructed by the *Employer* at the *Employer's* expense, and conducted in line with South African legislation.

Annexure A: One-in-ten-year-return weather data obtained from SA Weather Bureau for [weather station]

If any one of these *weather measurements* recorded within a calendar month, before the Completion Date for the whole of the *works* and at the place stated in this Contract Data is shown to be more adverse than the amount stated below then the *Contractor* may notify a compensation event.

Month	Weather measurement				
	Cumulative rainfall (mm)	Number of days with rain more than 10mm	Number of days with min air temp < 0 deg.C	Number of days with snow lying at 08:00 CAT	[Other measurements if applicable]
January	[•]	[•]	[•]	[•]	
February	[•]	[•]	[•]	[•]	
March	[•]	[•]	[•]	[•]	
April	[•]	[•]	[•]	[•]	
May	[•]	[•]	[•]	[•]	
June	[•]	[•]	[•]	[•]	
July	[•]	[•]	[•]	[•]	
August	[•]	[•]	[•]	[•]	
September	[•]	[•]	[•]	[•]	
October	[•]	[•]	[•]	[•]	
November	[•]	[•]	[•]	[•]	
December	[•]	[•]	[•]	[•]	

Only the difference between the more adverse recorded weather and the equivalent measurement given above is taken into account in assessing a compensation event.

C1.2 Contract Data

Part two - Data provided by the Contractor

Clause	Statement	Data
10.1	The <i>Contractor</i> is (Name): Address Tel No. Fax No.	
11.2(8)	The <i>direct fee percentage</i> is The <i>subcontracted fee percentage</i> is	% %
11.2(18)	The <i>working areas</i> are the Site and	
24.1	The <i>Contractor's</i> key persons are: 1 Name: Job: Responsibilities: Qualifications: Experience: 2 Name: Job Responsibilities: Qualifications: Experience:	
11.2(3)	The <i>completion date</i> for the whole of the <i>works</i> is	
11.2(14)	The following matters will be included in the Risk Register	
11.2(19)	The Works Information for the <i>Contractor's</i> design is in:	
31.1	The programme identified in the Contract Data is	
A	Priced contract with activity schedule	

11.2(20)	The <i>activity schedule</i> is in	South African Rands (ZAR)
11.2(30)	The tendered total of the Prices is	

C1.3 Forms of Securities

Pro formas for Bonds & Guarantees

For use with the NEC3 Engineering & Construction Contract

The *conditions of contract* stated in the Contract Data Part 1 include the following Secondary Options:

Option X13: Performance Bond

Each of these secondary Options requires a bond or guarantee "in the form set out in the Works Information". Pro forma documents for these bonds and guarantees are provided here for convenience but are to be treated as part of the Works Information.

Option X16: Retention (not used with Option F)

The *Contractor* may provide a Retention Money Guarantee in the form stated here. When the *Employer* receives and accepts a Retention Money Guarantee exactly in the form stated he will instruct the *Project Manager* not to assess any amount be retained in terms of secondary Option X16.

The *Contractor* shall guarantee his ASGI-SA Obligations by providing the *Employer* with an ASGI-SA Guarantee in the form provided here.

The organisation providing the bond / guarantee does so by copying the pro forma document onto his letterhead without any change to the text or format and completing the required details. The completed document is then given to the *Employer* within the time stated in the contract.

Pro forma Performance Bond – Demand Guarantee (for use with Option X13)

(to be reproduced exactly as shown below on the letterhead of the Contractor's Parent Company)

Eskom Holdings SOC Ltd
Megawatt Park
Maxwell Drive
Sandton
Johannesburg

Date:

Dear Sirs

Reference No. [●] [Drafting Note: Bank reference number to be inserted]

Performance Bond – Demand Guarantee: [Drafting Note: Name of Contractor to be inserted]

Project [] Contract Reference: [Drafting Note: Contractor contract reference number to be inserted]

1. In this Guarantee the following words and expressions shall have the following meanings:-
 - 1.1 "Bank" - means [●], [●] Branch, (Registration No. [●]); [Drafting Note: Name of Bank to be inserted]
 - 1.2 "Bank's Address" - means [●]; [Drafting Note: Bank's physical address to be inserted]
 - 1.3 "Contract" – means the written agreement relating to the Project, entered into between Eskom and the Contractor, on or about the [●] day of [●] 200[●] (Contract Reference No. [.]as amended, varied, restated, novated or substituted from time to time; [Drafting Note: Signature Date and Contract reference number to be inserted])
 - 1.4 "Contractor" – means [●] a company registered in accordance with the laws of [●] under Registration Number [●]. [Drafting Note: Name and details of Contractor to be inserted]
 - 1.5 "Eskom" - means Eskom Holdings SOC Ltd, a company registered in accordance with the laws of the Republic of South Africa under Registration Number 2002/015527/30].
 - 1.6 "Expiry Date" - means the date on which the Defects Certificate is issued in terms of the Contract.
 - 1.7 "Guaranteed Sum" - means the sum of R [●] ([●] Rand);
 - 1.8 "Project" - means [insert if applicable.].
2. At the instance of the Contractor, we the undersigned _____ and _____, in our respective capacities as _____ and _____ of the Bank, and duly authorized thereto, confirm that we hold the Guaranteed Sum at the disposal of Eskom, as security for the proper performance by the Contractor of all of its obligations in terms of and arising from the Contract and hereby undertake to pay to Eskom, on written demand from Eskom received prior to the Expiry Date, any sum or sums not exceeding in total the Guaranteed Sum.
3. A demand for payment under this guarantee shall be made in writing at the Bank's address and shall:
 - 3.1 be signed on behalf of Eskom by a Group Executive, Divisional Executive, Senior General Manager, General Manager or its delegate;
 - 3.2 state the amount claimed ("the Demand Amount");
 - 3.3 state that the Demand Amount is payable to Eskom in the circumstances contemplated in the Contract.

4. Notwithstanding the reference herein to the Contract the liability of the Bank in terms hereof is as principal and not as surety and the Bank's obligation/s to make payment:
 - 4.1 is and shall be absolute provided demand is made in terms of this bond in all circumstances; and
 - 4.2 is not, and shall not be construed to be, accessory or collateral on any basis whatsoever.
5. The Bank's obligations in terms of this Guarantee:
 - 5.1 shall be restricted to the payment of money only and shall be limited to the maximum of the Guaranteed Sum; and
 - 5.2 shall not be discharged and compliance with any demand for payment received by the Bank in terms hereof shall not be delayed, by the fact that a dispute may exist between Eskom and the Contractor.
6. Eskom shall be entitled to arrange its affairs with the Contractor in any manner which it sees fit, without advising us and without affecting our liability under this Guarantee. This includes, without limitation, any extensions, indulgences, release or compromise granted to the Contractor or any variation under or to the Contract.
7. Should Eskom cede its rights against the Contractor to a third party where such cession is permitted under the Contract, then Eskom shall be entitled to cede to such third party the rights of Eskom under this Guarantee on written notification to the Bank of such cession.
8. This Guarantee:
 - 8.1 shall expire on the Expiry Date until which time it is irrevocable;
 - 8.2 is, save as provided for in 7 above, personal to Eskom and is neither negotiable nor transferable;
 - 8.3 shall be returned to the Bank upon the earlier of payment of the full Guaranteed Sum or expiry hereof;
 - 8.4 shall be regarded as a liquid document for the purpose of obtaining a court order; and
 - 8.5 shall be governed by and construed in accordance with the law of the Republic of South Africa and shall be subject to the jurisdiction of the Courts of the Republic of South Africa.
 - 8.6 Any claim which arises or demand for payment received after expiry date will be invalid and unenforceable.
9. The Bank chooses domicilium citandi et executandi for all purposes in connection with this Guarantee at the Bank's Address.

Signed at _____ Date _____

For and behalf of the Bank

Bank Signatory: _____ Bank Signatory: _____

Witness: _____ Witness: _____

Bank's seal or stamp

Pro forma ASGI-SA Guarantee

(to be reproduced exactly as shown below on the letterhead of the Bank providing the Guarantee)

Eskom Holdings Limited
Megawatt Park
Maxwell Drive
Sandton
Johannesburg

Date:

Dear Sirs

Reference No. [●] [Drafting Note: Bank reference number to be inserted]

Pro-Forma ASGI-SA Guarantee: [Drafting Note: Name of Contractor to be inserted]

Project [] Contract Reference: [●] [Drafting Note: Contractor contract reference number to be inserted]

1. In this Guarantee the following words and expressions shall have the following meanings:-
 - 1.1 "Bank" - means [●], [●] Branch, (Registration No. [●]); [Drafting Note: Name of Bank to be inserted]
 - 1.2 "Bank's Address" - means [●]; [Drafting Note: Bank's physical address to be inserted]
 - 1.3 "Contract" – means the written agreement relating to the Project, entered into between the *Employer* and the *Contractor*, on or about the [●] day of [●] 200[●] (Contract Reference No. [●] as amended, varied, restated, novated or substituted from time to time; [Drafting Note: Signature Date and Contract reference number to be inserted])
 - 1.4 "*Contractor*" – means [●] a company registered in accordance with the laws of [●] under Registration Number [●]. [Drafting Note: Name and details of Contractor to be inserted]
 - 1.5 "*Contractor's ASGI-SA Obligations*" – means the *Contractor's ASGI-SA Obligations* under and as defined in the Contract.
 - 1.6 "*Employer*" - means Eskom Holdings Limited, a company registered in accordance with the laws of the Republic of South Africa under Registration Number 2002/015527/06.
 - 1.7 "Expiry Date" - means the [●] day of [●] 200[●]; [Drafting Note: anticipated date of issue of ASGI-SA Performance Certificate to be inserted.]
 - 1.8 "Guaranteed Sum" - means the sum of R [●] ([●] Rand);
 - 1.9 "Project" – means the
2. At the instance of the *Contractor*, we the undersigned _____ and _____, in our respective capacities as _____ and _____ of the Bank, and duly authorized thereto, confirm that we hold the Guaranteed Sum at the disposal of the *Employer*, as security for the proper performance by the *Contractor* of the *Contractor's ASGI-SA Obligations* and hereby undertake to pay to the *Employer*, on written demand from the *Employer* received prior to the Expiry Date, any sum or sums not exceeding in total the Guaranteed Sum.
3. A demand for payment under this guarantee shall be made in writing at the Bank's address and shall:
 - 3.1 state the amount claimed ("the Demand Amount");

- 3.2 state that the Demand Amount is payable to the *Employer* in the circumstances contemplated in the Contract.
4. Notwithstanding the reference herein to the Contract the liability of the Bank in terms hereof is as principal and not as surety and the Bank's obligation/s to make payment:
- 4.1 is and shall be absolute provided demand is made in terms of this bond in all circumstances; and
- 4.2 is not, and shall not be construed to be, accessory or collateral on any basis whatsoever.
5. The Bank's obligations in terms of this Guarantee:
- 5.1 shall be restricted to the payment of money only and shall be limited to the maximum of the Guaranteed Sum; and
- 5.2 shall not be discharged and compliance with any demand for payment received by the Bank in terms hereof shall not be delayed, by the fact that a dispute may exist between the *Employer* and the *Contractor*.
6. The *Employer* shall be entitled to arrange its affairs with the *Contractor* in any manner which it sees fit, without advising us and without affecting our liability under this Guarantee. This includes, without limitation, any extensions, indulgences, release or compromise granted to the *Contractor* or any variation under or to the Contract.
7. Should the *Employer* cede its rights against the *Contractor* to a third party where such cession is permitted under the Contract, then the *Employer* shall be entitled to cede to such third party the rights of the *Employer* under this Guarantee on written notification to the Bank of such cession.
8. This Guarantee:
- 8.1 shall expire on the Expiry Date until which time it is irrevocable;
- 8.2 is, save as provided for in 7 above, personal to the *Employer* and is neither negotiable nor transferable;
- 8.3 shall be returned to the Bank upon the earlier of payment of the full Guaranteed Sum or expiry hereof;
- 8.4 shall be regarded as a liquid document for the purpose of obtaining a court order; and
- 8.5 shall be governed by and construed in accordance with the law of the Republic of South Africa and shall be subject to the jurisdiction of the courts of the Republic of South Africa.
- 8.6 Any claim which arises or demand for payment received after expiry date will be invalid and unenforceable.
9. The Bank chooses domicilium citandi et executandi for all purposes in connection with this Guarantee at the Bank's Address.

Signed at _____

Date _____

For and behalf of the Bank

Bank Signatory: _____

Bank Signatory: _____

Witness: _____

Witness: _____

Bank's seal or stamp

PART 2: PRICING DATA

ECC3 Option A

Document reference	Title	No of pages
C2.1	Pricing assumptions: Option A	
C2.2	The <i>activity schedule</i>	

C2.1 Pricing assumptions: Option A

How work is priced and assessed for payment

Clause 11 in NEC3 Engineering and Construction Contract, (ECC3) Option A states:

Identified and defined terms 11
11.2 (20) The Activity Schedule is the *activity schedule* unless later changed in accordance with this contract.

(27) The Price for Work Done to Date is the total of the Prices for

- each group of completed activities and
- each completed activity which is not in a group.

A completed activity is one which is without Defects which would either delay or be covered by immediately following work.

(30) The Prices are the lump sum prices for each of the activities on the Activity Schedule unless later changed in accordance with this contract.

This confirms that Option A is a lump sum form of contract where the work is broken down into activities, each of which is priced by the tendering contractor as a lump sum. Only completed activities are assessed for payment at each assessment date; no part payment is made if the activity is not completed by the assessment date.

Function of the Activity Schedule

Clause 54.1 in Option A states: "Information in the Activity Schedule is not Works Information or Site Information". This confirms that specifications and descriptions of the work or any constraints on how it is to be done are not included in the Activity Schedule but in the Works Information. This is further confirmed by Clause 20.1 which states, "The *Contractor* Provides the Works in accordance with the Works Information". Hence the *Contractor* does **not** Provide the Works in accordance with the Activity Schedule. The Activity Schedule is only a pricing document.

Link to the programme

Clause 31.4 states that "The *Contractor* provides information which shows how each activity on the Activity Schedule relates to the operations on each programme which he submits for acceptance". Ideally the tendering contractor will develop a high level programme first then resource each activity and thus arrive at the lump sum price for that activity both of which can be entered into the *activity schedule*.

Preparing the *activity schedule*

Generally it is the tendering contractor who prepares the *activity schedule* by breaking down the work described within the Works Information into suitable activities which can be well defined, shown on a programme and priced as a lump sum.

The *Employer*, in his Instructions to Tenderers or in a Tender Schedule, may have listed some items that he requires the *Contractor* to include in his *activity schedule* and be priced accordingly.

It is assumed that in preparing his *activity schedule* the *Contractor*:

- Has taken account of the guidance given in the ECC3 Guidance Notes pages 19 and 20;
- Understands the function of the Activity Schedule and how work is priced and paid for;
- Is aware of the need to link the Activity Schedule to activities shown on his programme;
- Has listed and priced activities in the *activity schedule* which are inclusive of everything necessary and incidental to Providing the Works in accordance with the Works Information, as it was at the time of tender, as well as correct any Defects not caused by an *Employer's* risk;
- Has priced work he decides not to show as a separate activity within the Prices of other listed activities in order to fulfil the obligation to complete the *works* for the tendered total of the Prices.
- Understands there is no adjustment to the lump sum Activity Schedule price if the amount, or quantity, of work within that activity later turns out to be different to that which the *Contractor* estimated at time of tender. The only basis for a change to the Prices is as a result of a compensation event.

C2.2 the *activity schedule*

DETAILED ACTIVITY SCHEDULED TO BE REQUESTED FROM THE TECHNICALLY COMPLIANT TENDERERS

PART 3: SCOPE OF WORK

Document reference	Title	No of pages
	This cover page	1
C3.1	<i>Employer's Works Information</i>	
C3.2	<i>Contractor's Works Information</i>	
	Total number of pages	

C3.1: EMPLOYER’S WORKS INFORMATION

Contents

Part 3: Scope of Work	4
C3.1: Employer’s works Information	5
1 Description of the <i>works</i>	7
1.1 Executive overview	7
1.2 <i>Employer’s</i> objectives and purpose of the <i>works</i>	8
1.3 Interpretation and terminology	8
2 Management and start up.	11
2.1 Management meetings	11
2.2 Documentation control	12
2.3 Health and safety risk management	13
2.4 Environmental constraints and management	14
2.5 Quality assurance requirements	15
2.6 Programming constraints	17
2.7 <i>Contractor’s</i> management, supervision and key people	18
2.8 Invoicing and payment	18
2.9 Insurance provided by the <i>Employer</i>	19
2.10 Contract change management	19
2.11 Provision of bonds and guarantees	19
2.12 Records of Defined Cost, payments & assessments of compensation events to be kept by the <i>Contractor</i>	
2.13 Training workshops and technology transfer	20
3 Engineering and the <i>Contractor’s</i> design	21
3.1 <i>Employer’s</i> design	
3.2 Parts of the <i>works</i> which the <i>Contractor</i> is to design	24
3.3 Procedure for submission and acceptance of <i>Contractor’s</i> design	
3.4 Other requirements of the <i>Contractor’s</i> design	
3.5 Use of <i>Contractor’s</i> design	
3.6 Design of Equipment	
3.7 Equipment required to be included in the <i>works</i>	
3.8 As-built drawings, operating manuals and maintenance schedules	24
4 Procurement	25
4.1 People	25
4.1.1 Minimum requirements of people employed on the Site	25
4.1.2 BBEE and preferencing scheme	26
4.1.3 Accelerated Shared Growth Initiative – South Africa (ASGI-SA)	
4.2 Subcontracting	27
4.2.1 Preferred subcontractors	27
4.2.2 Subcontract documentation, and assessment of subcontract tenders	28
4.2.3 Limitations on subcontracting	
4.2.4 Attendance on subcontractors	
4.3 Plant and Materials	28
4.3.1 Quality	28
4.3.2 Plant & Materials provided “free issue” by the <i>Employer</i>	28
4.3.3 <i>Contractor’s</i> procurement of Plant and Materials	29
4.3.4 Spares and consumables	29
4.4 Tests and inspections before delivery	29
4.5 Marking Plant and Materials outside the Working Areas	30
4.6 <i>Contractor’s</i> Equipment (including temporary works)	30
4.7 Cataloguing requirements	30
5 Construction	31
5.1 Temporary works, Site services & construction constraints	31

5.1.1	<i>Employer's</i> Site entry and security control, permits, and Site regulations	31
5.1.2	Restrictions to access on Site, roads, walkways and barricades	31
5.1.3	People restrictions on Site; hours of work, conduct and records	31
5.1.4	Health and safety facilities on Site	31
5.1.5	Environmental controls, fauna & flora, dealing with objects of historical interest	32
5.1.6	Title to materials from demolition and excavation	32
5.1.7	Cooperating with and obtaining acceptance of Others	32
5.1.8	Publicity and progress photographs	32
5.1.9	<i>Contractor's</i> Equipment	32
5.1.10	Equipment provided by the <i>Employer</i>	
5.1.11	Site services and facilities	
5.1.12	Facilities provided by the <i>Contractor</i>	33
5.1.13	Existing premises, inspection of adjoining properties and checking work of Others	33
5.1.14	Survey control and setting out of the <i>works</i>	
5.1.15	Excavations and associated water control	33
5.1.16	Underground services, other existing services, cable and pipe trenches and covers	33
5.1.17	Control of noise, dust, water and waste	33
5.1.18	Sequences of construction or installation	34
5.1.19	Giving notice of work to be covered up	34
5.1.20	Hook ups to existing works	34
5.2	Completion, testing, commissioning and correction of Defects	34
5.2.1	Work to be done by the Completion Date	34
5.2.2	Use of the <i>works</i> before Completion has been certified	
5.2.3	Materials facilities and samples for tests and inspections	34
5.2.4	Commissioning	34
5.2.5	Start-up procedures required to put the <i>works</i> into operation	35
5.2.6	Take over procedures	35
5.2.7	Access given by the <i>Employer</i> for correction of Defects	35
5.2.8	Performance tests after Completion	35
5.2.9	Training and technology transfer	35
5.2.10	Operational maintenance after Completion	35
6	Plant and Materials standards and workmanship	36
6.1	Investigation, survey and Site clearance	36
6.2	Building works	36
6.3	Civil engineering and structural works	36
6.4	Electrical & mechanical engineering works	37
6.5	Process control and IT works	37
6.6	Other [as required]	
7	List of drawings	37
7.1	Drawings issued by the <i>Employer</i>	37
C3.2	<i>Contractor's</i> Works Information	38

Description of the works

Executive overview

The appointed engineering entity is required to design and install 22 PV systems at 22 customers premises. The installation to be done outside the customer's houses. The size of the PV system for each premise is shown on the table above.

The SSEG system to be configured so that the battery discharges during the morning (5-9am) and evening peak periods (5-9pm), when irradiance is low. During the day, the PV array recharges the battery and supplies the household load. The installation to be grid-tied; any surplus PV generation will be exported to the grid.

In addition, the appointed entity is required to undertake maintenance work for the duration of 2 years.

Detailed Scope of Work

Design and install 22 PV solar systems at 22 customer's premises. The systems shall be as follows:

18 X 3 kW PV Systems with a minimum of 5 panels each

4 X 5 kW PV Systems with a minimum of 9 panels each

Details of the PV mounting structure shall be provided for an outdoor-only, platform-mounted PV array that accommodates a dedicated IP65-rated kiosk enclosure. The platform and racking system shall be engineered to support the PV modules and provide sufficient space and access for the kiosk housing the battery system, inverter(s), and all supporting balance-of-system equipment (including protection, isolation, metering, communications and cabling). The submission shall include the installation methodology/procedure, structural support details, and associated engineering drawings.

Details of the outdoor IP65 kiosk enclosure for the inverter and battery system shall be provided. The kiosk shall be suitable for external environmental exposure and shall include all required internal mounting arrangements, ventilation/thermal management where applicable, gland plates/cable entries, and access provisions. The submission shall include the mounting/installation method or procedure, kiosk layout and general arrangement drawings, and technical data sheets for the kiosk and all installed equipment.

A solution for the reconfiguration, segregation, and outdoor enclosure of the existing service connection shall be provided. This shall include an IP65-rated outdoor enclosure arrangement integrated into, or suitably positioned adjacent to, the platform/kiosk installation. The submission shall include the mounting/installation method or procedure, single-line integration approach, and associated drawings showing the final service connection configuration and interfaces to the PV, inverter, battery and kiosk equipment.

Theft mitigation measures to be included in the design.

Employer's objectives and purpose of the works



Interpretation and terminology









The following abbreviations are used in this Works Information:

Abbreviation	Meaning given to the abbreviation
AFC	Approved for construction
OBL	Outside battery limits
ERA	Execution Release Approval
COW	Clerk of Works
PM	Programme Manager
PC	Project Co-ordinator
NED	Network Engineering Design
FDP	Final Design Package
DDP	Detailed Design Package
DoE	Department of Energy
SMS	Short Message Service
S&I	Standards and Implementations
CPE	Consultant Project Engineer
Dx	Eskom Distribution Division
CNC	Customer Network Centre
KZN OU	Kwazulu-Natal Operating Unit
TBA	To be announced
PM	Project Manager
QS	Quantity Surveyor
BBBEE	Broad Based Black Economic Empowerment
PPPFA	Procurement Preferential Policy Framework Act
KZN	Kwa Zulu Natal Operating Unit

Acceptance of Eskom SHEQ Policies and Procedures

The attached documents form part of this legal binding contract, the *Contractor* confirms that he has familiarized himself with all the embedded documents from 1 to 25 as indicated

No	UNIQUE IDENTIFIER	REVISION	DOCUMENT TITLE
1	32 - 727	0	SAFETY, HEALTH, ENVIRONMENT AND QUALITY (SHEQ) POLICY 32-727
2	32 - 136	0	CONSTRUCTION SAFETY HEALTH AND ENVIRONMENTAL MANAGEMENT
3	ESKOM LIFE SAVING RULES	1	ESKOM LIFE SAVING RULES 240-62196227
4	CONSTRUCTION REG 3		NOTIFICATION OF CONSTRUCTION WORK TO DEPARTMENT OF LABOUR
5	CONSTRUCTION REG 4 & 5		APPOINTMENT LETTERS FOR CLIENT REPRESENTATIVE, PRINCIPAL CONTRACTOR & CONTRACTOR
6 & 7	OHS ACT	1	WRITTEN AGREEMENT ON OHS ACT SECTION 37(2) & STANDARD CLAUSE
8 & 9	34 - 1063	0	<p>EXPANDED PUBLIC WORKS REPORT 34-1063.</p> <div style="display: flex; justify-content: space-around;"> <div style="text-align: center;">  10_34-1063 EPWP Works Instruction.pd </div> <div style="text-align: center;">  11_EPWP Guidelines Second edition 2005. </div> </div> <div style="text-align: center; margin-top: 20px;">  Eskom EPWP report template rev 7.xlsx </div>
10	DST 34-961	0	LEGAL APPOINTMENTS AND AUTHORIZATIONS

			 13_Legal Appointments and Au
11	TPC 41-55		TRANSPORTING PERSONS ON BACK OF VEHICLES  14_Transporting of Passengers on the ba
12	LTIR	MASTER	LOST TIME INJURY REPORT  LTIR Master.xls
13	Contractor Performance Evaluation	MASTER	 Single Evaluator Template for Contrac
14	Supplier Contract Quality Requirements	MASTER	
15	Hard Hat Specifications OHS 01/12/	MASTER	 OHS 01 12 Hard Hat Specifications.pdf
16	Identifying, Analysing, Documenting and Observing Tasks according to Criticality.	REV 1	 DPC_34-380.pdf
17	Health & Safety Representatives inspection reports and guidelines	REV 1	 DPC_34-228Health_ Safety_REp.pdf
18	Work at Heights Procedure	REV 1	 32-418 Work at Height Procedure.pdf
19	SHE Requirements for the Eskom Commercial Process	REV 1	

20	COVID-19 OCCUPATIONAL HEALTH AND SAFETY MEASURES IN WORKPLACES COVID-19 (C19 OHS), 2020		
21	Vehicle Safety	REV 0	
22	1.32-95 Environmental Occupational Health and Safety Incident Management Procedure	REV 5	
23	Risk Audit System Template	REV 0	 Audit Input Form Contractor RM 29 Sep

Acknowledgement by Contractor

I/WE, DO HEREBY ACKNOWLEDGE HAVING READ AND UNDERSTOOD THE ABOVE ANNEXED DOCUMENTS FROM 1 TO 25 IN SECTION 1.3.2 OF THIS CONTRACT.

I/WE UNDERTAKE TO STUDY AND ABIDE BY THESE REQUIREMENTS AT ALL TIME.

SIGNED AT: ON THE DAY OF20.....

Note: Please return the above pages with the other tender returnables to the Eskom office that issued this enquiry after complying with the above.

Management and start up.

Management meetings

Regular meetings of a general nature may be convened and chaired by the *Project Manager* as follows:

Title and purpose	Approximate time & interval	Location	Attendance by:
Kick off meetings		On site	PM, QS, Site Supervisor, Safety and Environmental Representatives and the Contractor.
Risk Register and compensation events	Weekly	On site	PM, QS, Site Supervisor, Safety and Environmental Representatives and the Contractor.
Overall contract progress and feedback	Weekly	On site	PM, QS, Site Supervisor, Safety and Environmental Representatives and the Contractor
Site meetings	Monthly	On site	PM, QS, Site Supervisor, Safety

			and Environmental Representatives and the Contractor
Health and safety meetings	Monthly	On site	<i>PM, QS, Site Supervisor, Safety and Environmental Representatives and the Contractor</i>
Community based meeting	Beginning of the project	On site	<i>PM, QS, Site Supervisor, Safety and Environmental Representatives and the Contractor</i>
assessment	Daily before work begins.	Site	<i>Contractor and Site Supervisor.</i>
Risk register and compensation events	As necessary.	Site	<i>PM, Contractor and Site supervisor</i>
Performance appraisal meeting	At project completion	On site and office	<i>PM, QS, Site Supervisor, Safety and Environmental Representatives and the Contractor</i>
Pre- outage meeting	When there are outages	On site	<i>PM, QS, Site Supervisor, Safety and Environmental Representatives and the Contractor</i>
Public safety meeting	Beginning of the project	On site	Project stakeholders

Meetings of a specialist nature may be convened as specified elsewhere in this Works Information or if not so specified by persons and at times and locations to suit the Parties, the nature and the progress of the *works*. Records of these meetings shall be submitted to the *Project Manager* by the person convening the meeting within five days of the meeting.

All meetings shall be recorded using minutes or a register prepared and circulated by the person who convened the meeting. Such minutes or register shall not be used for the purpose of confirming actions or instructions under the contract as these shall be done separately by the person identified in the *conditions of contract* to carry out such actions or instructions.

Documentation control

All contractual documents must have relevant contract number and purchase order number of reference The Contractor to ensure that all documentation relating to this contract is filed and kept on site for viewing by the Project Manager at any time. The Contractor must ensure that all documents are also kept in soft copy and backed up on a hard drive which must be handed to the Service Manager at the end of the contract. Files are to be neatly labelled and indexed.

All correspondence shall be dated and sequentially numbered and distributed in accordance with a procedure as agreed and accepted by the Project Manager.

Eskom will periodically request detailed reports from the Contract. All contractual documentation must have relevant contract number and Purchase Order Number as reference as per Eskom Holdings SOC Limited Standards (List). Contractual communications will be in the form of properly compiled letters, letters attached to emails, emails and NEC standard templates as outlined on core clause 13 of the NEC3 ECC.

The use of emails does not override the use of applicable and relevant NEC3 ECC standard templates, forms and Eskom Holdings SOC Limited procedures.

Note: It is the contractor responsibility to acquire and familiarise themselves with the NEC3 ECC.

Health and safety risk management

The Contractor shall control his activities and processes in accordance with the Occupational Health & Safety Act, No. 85 of 1993 and Eskom's Construction Safety, Health and Environmental Management 32-136 (with the provided SHE Specification), Safety, Health, Environment and Quality Policy, EPC32-727 and SHE Requirements for the Eskom Commercial Process, ST32-726. The Contractor shall comply with the health and safety requirements contained in Section 1.3.2 of this Works Information.

The Contractors Project SHEQ File is to be updated on a continuous basis. The Contractor is to ensure that all relevant documentation and authorisations are contained in the file pertaining to the project. Upon completion of the project, the Contractor is to convert all documentation contained in the SHEQ file into electronic format and save it as a PDF File. The file name should contain the name of the Contractor and the project. The file should then be saved onto a disk or removal storage device and handed over to the Project Coordinator or Project Manager upon completion of the project.

The Contractor should adhere to the Life Saving Rules at all times.

Due to the importance to safe life's and apparatus of Eskom it is recommended that if a contractor abuse any Life Saving Rules, all work allocated to the contractor will immediately put on hold until final outcome with investigation. Safety is the combined responsibility of the team and therefore team leader or team will be punished together. There are five cardinal rules that may not be broken by the Team Leader and his/her team.

The six Eskom Life Saving Rules are as follows:

Rule 1:*Open, Isolate, test, earth, and create an equipotential zone before touch*

Rule 2:*Hook up at height*

Rule 3:*Buckle Up*

Rule 4:*Be Sober*

Rule 5:*Ensure that you have a permit to work*

Rule 6:*Ensure Safe Live Working*

The Contractor shall comply with the following health and safety requirements to this Works Information.

32-727	1	Eskom SHEQS Policy	Y
32-95	4	Eskom Procedure for the effective management of Safety, Health and Environmental related incidents	Y
240-72597722	1	Eskom Procedure Environmental Impact Assessment For Distribution Activities	Y
32-247	1	Eskom Procedure For Vegetation Clearance And Maintenance Within Overhead Powerline Servitudes And Eskom-Owned Land	Y
EPC 32-245		Eskom's Waste Management Procedure	Y
RAS	Feb. 2014	Eskom Risk Auditing System Checklist for Contractors	Y
Act 108 of 1996		Constitution of the Republic of South Africa	N
Act 107 of 1998		National Environmental Management Act	N
Act 84 Of 1998		National Forest Act	N
Act 73 Of 1989		Environment Conservation Act	N

Act 25 Of 1999		National Heritage Resources Act	N
Act 36 Of 1998		National Water Act	N
Act 59 Of 2008		National Environmental Management: Waste Act	N
<p>ADDITIONAL LEGISLATION ADDITIONAL LEGISLATION</p> <p>Conservation of Agricultural Resources Act (Act 43 Of 1983)</p> <p>Fertilisers, Farm Feeds, Agricultural Remedies and Stock Remedies Act (Act 36 of 1947)</p> <p>Game Theft Act (Act 105 Of 1991)</p> <p>National Veld and Forest Fire Act (Act 101 Of 1998)</p> <p>National Parks Act (Act 57 Of 1976)</p> <p>National Roads Act (Act 7 Of 1998)</p> <p>Advertising on Roads and Ribbon Development Act (Act 21 Of 1940)</p> <p>National Environmental Management: Protected Areas Act (Act 57 of 2003)</p> <p>National Environmental Management: Air Quality Act (Act 39 of 2004)</p> <p>National Environmental Management: Biodiversity Act (Act 10 of 2004)</p> <p>Occupational Health and Safety Act (Act 85 Of 1993)</p> <p>Fencing Act (Act 31 Of 1963)</p> <p>PROVINCIAL ORDINANCES MUNICIPALITY BYLAWS</p>			

Environmental constraints and management

The Contractor shall comply with the environmental criteria and constraints contained in the FDP and attached in Annexure B to this Works Information and consist of the following documentation to comply with:

- TQTGS011 Rev0 Environmental Legal Compliance for KZN OU Projects with DESD's signed.
- TQTGP056 DESD Process for KZN OU.
- 240-71555318 Distribution generic EMP for operations Maintenance Standard
- DPC_34-926 doc incorporating Water use issues draft 1 (3) (Repaired) draft 0A

In addition, the *Contractor* is required to ensure that all goods, services or works supplied in terms of this *Works Information* also conform to all applicable environment legislation(s), Safety, Health, Environment and Quality Policy, EPC32-727; SHE Requirements for the Eskom Commercial Process, ST32-726; (and additional requirements). The *Contractor* shall comply with the environmental criteria and constraints stated in Section 1.3.2.

When required, the *Contractor* must ensure that all *Subcontractors'* EMP comply with legal and other requirements and also includes all the environmental risks associated with the scope of work. The *Main*

(Principal) Contractor shall define the specific risks applicable to the Subcontractor's scope of work or supply of kiosks.

The Contractor is to send a flash report for any environmental incidents that have occurred on site as soon as possible or within 24 hours to the Eskom Environmental Representative and Project Manager clearly stating any impact to the environment.

No environmental records shall be destroyed or discarded by the Contractor. Eskom as the Employer and the Contractor shall agree that the Contractor retains certain environmental records. Waste generated during the course of the project must be disposed at a registered site and the Contractor shall retain records of disposal.

Deviations from these requirements will be regarded as a non-conformance. Should there be concerns regarding environmental performance and non-conformance to environmental requirements, management engagements and interventions will be introduced to determine a means to addressing the shortfalls. Once these interventions have been explored and exhausted, then the Eskom Supplier Disciplinary Process will be followed.

The cost to the Contractor to obtain permits should it become necessary to cut a protected tree, ensure that waste is disposed of on a permitted, legal waste site and all relevant costs payable to dumping site as well as safe storage of all equipment which will be removed and replaced from site which will be transported upon instruction to the nearest designated disposal site within the KZN Operating Unit

Notes and Requirements for Environmental Compliance

- Contractors must be aware of environmental specifications in contracts and comply with them;
- Contractors building new lines and substations, and performing maintenance on existing infrastructure to attend environmental law course;
- Legal contraventions involving contractors to be communicated to all other contractors to avoid recurrence;
- Contractors to follow and comply with EMP's provided;
- Contractors building new assets or maintaining existing assets to always have a copy of the EMP, EA and any other permits (tree, water, heritage) available on site where such documents exist;
- Contractors assisting with self-build projects for third parties to attend the DESD course;
- Contractors assisting with self-build projects for third parties to ensure that the relevant documentation including the DESD is handed over to and approved by the Land Development section. Such contractors take
- liability for the completion of the DESD;
- All environmental incidents to be brought under the attention of the Eskom Holdings SOC Limited representative within 24 hours;
- Contractors must demand/request a copy of the DESD for their projects);
- Read and understand the DESD and EMP;
- (K) Ensure all relevant staff are aware of the conditions of the DESD and EMP;
- Review DESD and EMP before tendering;
- Authorisations are only issued for specific projects after submissions of the Basic Assessment

Quality assurance requirements

Quality Assessment Criteria, Forms A of the QM-58 specification will be selected and completed by Eskom Representative who will identify the applicable Contractor quality requirements to be met. Form A of the QM-58 specification shall be signed by the Contractor responding to an Eskom Enquiry.

2.5.1 Contractor Quality Management System Requirements

The Contractor shall have formal Quality Management System in place in accordance with the requirements of the QM-58 specification.

Such formal system shall consist of the appropriate documentations such as work procedures, work instructions, method statements, work flow documentation etc. as the case may be. This requirement constitutes the most basic Quality Management System requirements.

Unless specifically excluded in the Quality Assessment Criteria, as per the Level of Quality Requirements (Level 1, 2, 3 or 4). The *Contractor* shall have a fully documented, implemented and maintained Quality Management System that complies with ISO-9001 standard. In the event that the *Contractor* invariably requires the assistance of some *Subcontractor* in order to realise its own supply obligations.

The aforementioned requirement applies equally in all cases where any such *Subcontractor's* scope of responsibility includes the provision of any of the following activities viz. Design & Development, Manufacturing, Testing, Storage, Delivery, Installation, Commissioning, and Project Management.

Unless specifically excluded in Quality Assessment Criteria, such Quality Management System shall carry valid ISO-9001 certification from an accredited certification body, as indicated in the applicable Eskom invitation (This requirement applies equally to both the *Contractor* and any/all manufacturing third party organizations mentioned above).

Eskom reserves the right to request and perform necessary assessments at *Subcontractor* facilities. The *Contractor* shall be responsible for defining the specific quality control elements applicable to the respective *Subcontractor's* scope of work/supply, and ensure that their *Subcontractor(s)* quality programmes support Eskom requirements

The *Contractor* shall inform Eskom of any proposed changes to the Quality Management System or staff that will affect the Quality System prior to implementation of these changes.

2.5.2 Quality Plan

The information in this section constitutes the minimum requirements for a Quality Plan:

- All individual products and processes shall have a documented, implemented and maintained Contract Quality Plan and/or Quality Control Plan (Inspection and Test Plan).
- All production and/or service provision shall be carried out in accordance with documented Contract Quality Plan (CQP) and/ or Quality Control Plan (QCP)/ Inspection and Test Plan (ITP).
- The *Contractor* shall plan for the required Quality related activities and interfaces within the *Contractor's* Quality system, in order to demonstrate its ability towards both controlling and meeting specified Eskom requirements

2.5.3 Contract Quality Plan

Contractor shall require *Subcontractors* to submit Contract Quality Plan (CQP) and associated documentation in accordance with requirements of Project Quality Management System processes applicable to *Subcontractor* Scope of Work.

Contractor shall, where applicable based on Scope of Work Criticality, ensure Procurement documents clearly and unambiguously require *Subcontractor* submission of a *Subcontractor* CQP for *Contractor* and Eskom review.

Contractor and *Subcontractor* CQP shall comply with Eskom "Quality Requirements Specifications" and shall be submitted prior to the initial Scope of Work Kick-off or initial Pre-fabrication meeting and prior to commencement of manufacturing, whichever is earlier

2.5.4 Quality Control Plan

Contractor shall develop and implement processes and procedures which efficiently and effectively monitor, verify and document Quality of Scope of Work deliverables. *Contractor* shall ensure that *Subcontractor* QCP/ITP's are prepared at a level of detail sufficient to address all Quality Control related activities in chronological order, from contract review through materials verification, manufacturing, fabrication, assembly, final testing, documentation, and certification.

Where activities subject to Inspection and Test procedures are to be undertaken by a *Subcontractor*, the QCP/ITP shall make reference to this fact and shall include descriptive details of *Subcontractors* involvement. A separate QCP/ITP shall be required for each *Subcontractor* Scope of Work.

Contractor may authorise use of *Subcontractor* QCP/ITP format providing it is in compliance with the above. *Contractor* shall be ultimately responsible for the development and proper implementation of all *Subcontractor* QCP/ITPs, including those reviewed or developed by *Subcontractors*.

Eskom reserves the right to select witness and hold points within all developed *Subcontractor* QCP/ITPs for Eskom oversight of selected functions and to perform surveillance or audits of the Work.

Contractor shall establish processes and procedures for formal assessment of *Subcontractor* inspection and testing programs. These shall include review of *Subcontractor* inspection reports and other Quality Control documentation. Additional formal assessment of manufacturing, fabrication and assembly facility operations shall be conducted by *Contractor* to ensure continuing suitability, adequacy and effectiveness of the *Subcontractor* inspection and testing programs. Assessment frequency shall be established in consideration of *Subcontractor* Scope of Work, Criticality of Scope of Work deliverables and performance information. Assessment scope and schedule shall be developed in consultation with Eskom.

Mandatory pre-inspection meetings will be convened by Eskom or its Inspection Agency or AIA to be attended by the *Contractor* and *Subcontractors* representatives, including their Quality representatives who will be involved with the Works and records to be kept.

Eskom reserves the right to appoint resident quality inspectors that can be based at the *Contractor* or *Subcontractor's* premises and on site where the work is being performed. The *Contractor* is expected to provide work space at no cost to Eskom, for the inspector as required.

Programming constraints

A comprehensive and fully detailed programme is to be submitted within the seven (7) days after the introductory meeting and should indicate all milestones and critical dates. This programme must first be approved by the *Project Manager* and must be updated on an as and when required basis by the *Project Manager*.

The following dates shall be clearly reflected on the programme:

- Starting and completion dates for all activities as well as relevant key dates for hold or witness points. All relevant significant activities shall be shown in order to monitor the progress in the factory/workshop.
- The programme shall also reflect a 2-week period for inspection and correcting of Defects before the completion date.

Updated programmes must be available at all meetings reflecting progress to date and the date when delivery will take place through the use of task orders.

FORMAT OF THE PROGRAM

- The *Contractor* shall submit his construction program in terms of the conditions of contract.
- The *Contractor* is to submit a revised programme for acceptance at each site meeting.
- This program shall be in the form of an approved Gantt Chart containing the following information:
- All construction activities, including milestones, initial tasks, critical path, required Outages, and target *Dates*. All potential risk activities should be clearly indicated on the critical path.
- Every activity on the programme will be clearly linked to labour resources and equipment required to perform the specific activity.
- Projected weekly progress on *site* for the entire duration of the contract.
- Completion and hand-over *Dates* for formal inspection by the site supervisor must be indicated.
- A column showing the daily tempo of all the construction activities must be indicated next to the activity on the programme.
- Project expenditure on a monthly basis for the entire duration of the contract.
- The following project phases and activities are minimum requirements for the programme:

- Site Establishment and Material Delivery – Lead times to be specified.
- Preparation work – Work that can be completed without the necessity of power outages
- Outage work – Work that must be completed under outage conditions
- Planned outages to be included in the programme
- *Contractors* float to be included in the programme
- The Contract Program will be on display in the *Contractors Site Offices* and will be updated weekly. In addition to the maintaining of this programme, the *Contractor* will report progress to the *Project Manager* at each site meeting or at request of the *Project Manager*.
- The *Contractor* shall also provide an organisation chart showing the personnel to be employed for the *works*, along with a detailed CV of all key personnel.
- Should any deviations to the program be found the *Contractor* shall submit a revised program to the *Project Manager* within one week of such deviations being brought to the *Contractor's* attention.
- The Outages must be arranged with *Employer* via the Outage arrangement procedures, as a pre-requisite for the acceptance of the programme by the *Project Manager*.
- Acceptance of any program by the *Project Manager* shall have no contractual status other than an indication that the *Project Manager* is satisfied as to the order in which the work is to be carried out, and that the *Contractor* undertakes to perform all work in accordance with the accepted program.
- The *Project Manager* retains the right to alter the accepted program should circumstances on *site* necessitate such a change.

OTHER INFORMATION TO BE SHOWN ON THE PROGRAM.

THE FOLLOWING STATUTORY NON-WORKING DAYS ARE INCLUDED WITHIN THE CONTRACT PERIOD:

- All Public Holidays for the duration of the contract.
- The programme must clearly indicate the non-working days for the entire construction period

Contractor's management, supervision and key people

The *Contractor* is to submit an organogram showing all key people involved in the contract 7 days after contract award. All key personnel must be appointed in writing, must be current for the specific site and area of work and must be kept on file. This would be essential if the *Contractor* is a Joint Venture.

The *Contractor* shall also provide a detailed organisation chart showing the personnel to be employed for the works, along with Training certificates of all key personnel. *Contractors* to submit proof to Eskom that their *Contracts manager* or delegated employee representative has NEC ECC training. A full definition of ONE team shall form part of the organisation chart per project and identity number shall form part of this document.

Invoicing and payment

Within one week of receiving a payment certificate from the *Project Manager* in terms of core clause 51.1, the *Contractor* provides the *Employer* with a tax invoice showing the amount due for payment equal to that stated in the *Project Manager's* payment certificate.

The *Contractor* shall address the tax invoice to Eskom Holdings SOC Ltd and include on each invoice the following information:

- Name and address of the *Contractor* and the *Project Manager*;
- The contract number and title;
- *Contractor's* VAT registration number;
- The *Employer's* VAT registration number 4740101508;
- Description of service provided for each item invoiced based on the Price List;
- Total amount invoiced excluding VAT, the VAT and the invoiced amount including VAT;

Procedures for Invoice Submission and Payment (e. g. Electronic Payment Instructions) General Information
- No Pro-forma Invoice
- Check Vendor number against the Address and name on Tax invoice
- Insert the Vendor number on Tax invoice (Top right hand corner)
- Bank details must be on the invoice or on a attach sheet, but it does not require a bank stamp just a letter)
- Check banking details on invoice against SAP system. If more than one banking account check bank account against banking details on invoice. If banking details not on invoice, write the bank code next to the vendor account (bank code 0002)
- Check Vendor VAT number against the vendor master. (FK03) If VAT number not on master records, prepare a list and forward to Vendor Management to check and update the vendor master records
- No fax copies of Tax invoices allowed
No copies of Tax invoices allowed unless originally printed by the Vendor if a photocopy tax invoice, it must be an original "certified copy" (i.e. not a copy of a "certified copy" invoice) from the vendor and check in system if not previously be paid. Put stamp "not previously paid" on invoice and sign.
- Ensure that date received stamp is clear on invoice
- Stamp all Invoices with the Vat stamp, complete and sign (only when VAT is applicable)
The stamp should not be stamped over any written information
- When scanning invoice, check the quality before linking in SAP (inboxes)
With Reference Invoices
- Goods receipt must be done (payment with reference)
- Ensure that the SAP purchase order number is clear and correct on the invoice
- GR number to be written on the Invoices
- If multiple lines on invoice write the line number of the order against the line to ensure that the processors match the correct lines (to ensure that 191100 is matched correctly)

Insurance provided by the *Employer*

Annual Contractors All Risks Insurance Policy ESK2019/20 ACAR

Contract change management

As per NEC ECC section 6 and applicable Z clauses

Provision of bonds and guarantees

The form in which a bond or guarantee required by the *conditions of contract* (if any) is to be provided by the *Contractor* is given in Part 1 Agreements and Contract Data, document C1.3, Sureties.

The *Employer* may withhold payment of amounts due to the *Contractor* until the bond or guarantee required in terms of this contract has been received and accepted by the person notified to the *Contractor* by the *Project Manager* to receive and accept such bond or guarantee. Such withholding of payment due to the *Contractor* does not affect the *Employer's* right to termination stated in this contract.

Training workshops and technology transfer

Describe type and frequency of on job training workshops, as well as any obligation for technology transfer being included as part of the contract on Completion of the *works*.

Engineering and the *Contractor's* design

The contractor shall execute the works as per the Approved Final Design Package (FDP)

The Contractor is to comply with the specifications as stated in the table below:

Specifications

Title	Date or revision	Tick if publicly available
General Specifications:		
Health and Safety requirements	Latest	
Environmental requirements	Latest	
Site regulations and access control	Latest	
Eskom Distribution Standard Copies available from Eskom Power Delivery Engineering, Simmerpan, Technical Administrator, Telephone 011-871 2214. Important Note: where material options (i.e coastal and inland) are available only the coastal option will be applicable for all such material used in Eskom's KZN Operating Unit .	Latest	
Engineering Instructions As issued by Eskom's Power Delivery Engineering-Simmer pan and Standards Implementation KZN OU Department, New Germany. Copies of the relevant Engineering Instructions are available on request.	Latest	
Technical Bulletins As issued by Eskom's Power Delivery Engineering, Simmer pan and Standards Implementation KZN OU-New Germany Copies of the relevant Bulletins are available on request.	Latest	
As-Built Drawings Specifications for As-Built Drawings Micro station Data Levels Standard MicroStation Design File Settings As-Built Drawing	Latest	
Environmental Management Environmental Management Programme (EMP) Procedure Environmental Management Policy. Copies of the relevant documents are available on request.	Latest	
Quality Replace with QM-58 Suppliers Contract Quality Requirement Specification. Copies of the relevant documents are available on request.	Latest	

Safety Occupational Health and Safety Requirements to be met by Contractors and Subcontractors Employed by Eskom. Co-ordination of Safety on Capital Projects Standard applicable to Contractors working in Close Proximity to Live Apparatus	Latest	Health & Safety Documents
Management of Substance Abuse. Copies of the relevant documents are available on request.	Latest	
Business Conduct Suspending Suppliers from Eskom's Supplier Lists Eskom Business Conduct Policy and Guidelines Declaration of Conflict of Interest Copies of the abovementioned documents are not attached but are available from Eskom's Tender Advise Centre on (031) 710 5429	Latest	
Standards Implementation-KZN OU Engineering Instruction : Generic Stubby Line-available on request from Standards Implementation Document Controller on 031-7105143.	Latest	
Authorisation of contractors / Eskom staff	Latest	TDQES001
Standard for a fall arrest system Procedure for using a fall arrest system Specification for a fall arrest system Copies of the relevant documents are available on request.	Latest	
Checklist of Eskom Qualified Suppliers List of Eskom Qualified Suppliers-available on request	Latest	

The Eskom Holdings SOC Limited Website has all Distribution Procedures, Standards and Drawings as listed.

All contractors must make sure that they can access Eskom Web page at any given time to get the latest drawings and specifications before commencement of any task. Web Access applications can be done through the assistance of the Design, Tools and Systems Department @ 011 629 5111.

General Specification

- The latest DDT Eskom Standards, Technical Bulletins and Engineering Instructions are to be used.
- The quality of work is to be audited by the contractor, before being inspected by the Project Manager or his representative.
- The contractor will provide a suitable site store and office as required by Eskom.
- Supply and erection of all LV & associated equipment as per the Schedule of Quantities.
- Supply & install structure labels & danger labels as per the Eskom Standard.
- Supply & install new stay assemblies as per the latest DDT0312 & 0313.
- Supply & install anti-climbing devices as per 05TI-09 and remove existing spikes as per 03-TB08. Where MV & LV Earths are on the same structure install UV protected black PVC pipe - 1.2m on each earth down-wire, cutting the top and bottom of the pipe at 45, split the pipe so as to insert the MV/LV earth and installing clout nails at the bottom and top.
- Supply & insulate jumpers correctly to the latest Eskom T&Q standards. All jumpers to links and transformers to be installed with HDPE, UV Stabilized PVC black pipe. Include crimps.
- Supply & install Road Crossing kits where road crossings exist.
- Ensure that the minimum 400mm required clearance between jumpers and any earthed points are met and is as specified by the relevant Eskom MV standards & OHS Act.
- All insulators must be of 31mm/kV creepage.
- Allow lead time for customer notification by the TSC before the outage, with an outage request form being filled out and an alternate date being set. Ensure sufficient trained teams are present to work under outage conditions with trained and experienced Supervisors.

- "Holes" that are caused as a result of the repositioning of hardware must be plugged & creosoted by the Contractor as per DDT3219. If the pole is deemed to be unsafe the pole must be replaced during the outage or another outage scheduled due to the safety risk of the pole snapping.
- Sag & Tension sheets and attachment of the existing MV Line as per the Eskom & OHS Standards. Dynamometer must be calibrated every 3 months as per the Eskom Standards.
- All crimping must comply with the latest Eskom standard.
- Contractor to ensure that the correct ties are used on lines. (i.e. twin/top etc)
- Jumpers to auxiliary devices must not be greater than 2m due to the risk of clashing conductors.
- Due to the break and build nature of the project and associated the limited time frames, regarding outage duration, an adequately qualified & trained safety officer must be present at all times. Work will be required in close proximity to live conductors and hence the Contractor must ensure full safety compliance at all times.
- The contractor is to ensure minimum requirements regarding registrations Wireman's License, Electricity Contactors Board registration, Operating Regulations for High Voltage, Mersey Training Accreditation, fully qualified and experienced supervisors.
- All materials supplied/offered are to conform to the Eskom Buyers Guide Part 9 and are to be procured from Eskom Qualified Suppliers, and shall be new and of the best quality. Any deviation or variance to this must be approved by the consultant & Eskom S&I Department, after a written request, prior to implementation. Where specific site circumstances require non-standard material and/or due to shortcomings of the standard package, the designer/contractor shall develop "ad hoc" packages and submit these to Eskom T&Q Department for approval before implementation.
- Excavations: Contractors must make themselves fully aware of the soil conditions during the tender process.
- All old material must be removed, loaded, transported, offloaded and safely & neatly stacked rolled up in cable drums in the Site Camp and then to the Eskom Asset Disposal Officer at New Germany. A Return to Stores form must be signed & forwarded to the Consultant.
- The relevant safety procedures must be followed regarding staff /personal and animals. No metal or foreign objects must be left after completion of the relevant structure. The contractor must not damage the surrounding environment and vegetation. Local farmers and landowners must be consulted before entering private property.
- During the site audit poles were identified that could possibly be rotten or in a bad condition. Such poles must be replaced and the soil compacted, as per the Eskom DDT Standard. All wooden poles, cross-arms, conductor and metal parts must be approached with extreme caution and deemed to be rotten or corroded and thus always suitably supported and analyzed prior to work being conducted on them.
- Phasing is the contractors' responsibility before and after task completion. Reverse phasing and incorrect connection of conductors will be for the Contractors account. Voltages must be verified prior to switch on. Any damage for contractors account.
- Any damage to customer equipment is for the contractors account.
- The Contractor must analyse drawings and recommended alternative solutions prior to the outage or during the tender process, if required. Any anticipated problems must be clearly detailed and priced under "additional items required" in the Bill of Quantities. The alternatives will be checked and if found technically and financially acceptable, approved for construction by the Consultant.
- Payment is only made for installed material and hence adequate Construction program is of vital importance.
- The Contractor must ensure that all persons on site have PPE at all times.
- Any damage to existing services shall be made good by the Contractor at his own expense and to the approval of the Project Manager.
- The supply and installation of 15m of 3/3.35x1100MPa steel wire for a BIL for each pole structure as per Eskom specification, including bonding of existing X-arms. Existing MV structures not to the present BIL standard must be brought up to standard. Refer to DDT0310 – and 03TB034 regarding insulation co-ordination and bonding for wooden poles.
- No mechanical drilling of excavations may be carried out under live MV / LV unless approved in writing by Eskom.

The attached documents form part of this legal binding contract, the Contractor confirms that he has familiarized himself with all the embedded documents from 1 to 12 as indicated.

Parts of the works which the Contractor is to design

As per the technical criteria of the advertised enquiry

As-built drawings, operating manuals and maintenance schedules

The Contractor completes as-built drawings and as-built schedule of quantities per transformer zone handed over as completed. The Contractor submits these as-built drawings and as-built schedule of quantities as part of the hand-over documentation in line with the completion dates indicated on the approved construction programme.

As-built service cable quantities:

The Contractor submits as-built service connection cable quantities in cable length (metre) per service connection completed. This information must be indicated on the as-built drawings and must be submitted as part of the as-built documentation as specified in item 15. Should the contractor fails to submit the service cable quantities with clear references to the Electrical Address and As-built drawing, an average service cable quantity of 40 m per connection will be accepted as the default length on payment will be certified.

Commissioning tests will included the insulation impedance testing on LV feeders, and voltage level readings for both off load and load conditions per LV feeder terminal.

The works are to be performed under competent supervision as defined by the OHS Act and as required by Eskom in terms of the HV Regulations. All safety related standards and specifications as specified under Annexure A to be strictly adhered to. Where line stringing in parallel to existing live lines take place, working earths are to be applied at all times in accordance with the specifications.

The Works are to be executed in phases in order to achieve the *Sectional Completion* targets.

Conflict between specifications and drawings

Should there be conflict between the specification and drawings, then documentation shall be considered in the order of priority set out below:

- Tender Correspondence/Minutes/Site Instructions
- Approved Sample Line
- Works Information & Final Design Package
- Drawings
- *Power Delivery Engineering* Standard
- Should the Contractor note any inconsistency between the specification and drawings he shall notify the *Project Manager* and obtain clarification or instructions prior to collecting and installing materials and plant for the work.

Procurement

People

Minimum requirements of people employed on the Site

All people employed by the *Contractor* to perform supervision of installation and commissioning should have Police Clearance before work can commence. The *Contractor's* employees shall be sober when carrying out their duties and may be subjected to random breathalyser tests

Extended Public Works Programme (EPWP) shall be applicable on all projects. The EPWP report template is included as supporting documentation and forms part of this Contract.

To be compiled by the Contractor:

- Base indicators to be collated on all EPWP projects (Table 1)

Table 1: Base indicators to be collected on all EPWP projects

B1 Number	Project level Indicator to be used in monitoring system	Comments
1	Number of people ("Different warm bodies") employed on relevant project	Will be assumed to be equivalent to number of job opportunities created. Will measure the number of people to benefit directly from the EPWP
2	Person-days of employment created	Total number of person days created will be divided by 230 to convert to person years of employment created
3	Minimum wage rate	Since local public bodies may set the wage rate as part of the EPWP to wage rate on a particular project will need to be reported
4	Number of training days provided	Since all workers are entitled to training it is important to ensure that actual training is delivered
5	Overall spending on the project	Will give an indication of how much is actually spent on EPWP projects
6	Demographics of workers on EPWP Projects	The percentages of women, youth and disabled to be reported on.

- KPI to be used for the EPWP (Table 2)

Table 2: KPI's to be used for the EPWP

KPI	KPI	Method for calculation	Comment
1	Number of Job opportunities created	Assumed to be equal to number of warm bodies employed per project	Will give an indication as to how many unemployed people benefit directly from the EPWP
2	Person years of employment created	Divide the total number of person days of all projects by 230 (Agreed upon number of person days of employment per year)	Indicator that shows the equivalent number of full-time jobs created
3	Number of training days provided	Total sum from all projects	Measure total amount of training provided
4	Overall spending on EPWP projects	Total sum from all projects	Measure total government spending on the EPWP
5	Demographics of workers on EPWP projects	Total sums of the project totals of women, youth and disabled employed	Measures the demographics of the people benefiting from the EPWP

6	Average length of employment created	Divide person years of employment created (KPI 2) by number of job opportunities (KPI 1)	Also allows comparison between sectors and types of projects
6	Total income paid out to previously unemployed workers	Multiply number of person-days (BI 2) by the minimum wage (BI 3)	
7	Average income of EPWP worker	Divide Total income (KPI 6) by Number of job opportunities (KPI 1)	
8	Average duration of training provided	Divide total number of training days (KPI 3) by number of job opportunities (KPI 1)	Provides an indication of the level of skills build in the programme
9	Percentage of spending paid out to EPWP workers	Divide total income paid out (KPI 6) by Overall spending on EPWP (KPI 4)	Measure the labour intensity of the EPWP

BBBEE and preferencing scheme

Special Conditions of Contract (Application of other criteria in terms of Section 2(1)(f) of PPPFA)

The objective criteria as follow:

Transformation of this sector by the appointment of a Black Owned Firm(s) that meet the functionality requirements;
Development of Black Owned steel fabrication companies;
Appointment of companies located within the Republic of South Africa.

NB: The joint Venture may be

Black Owned and Black Owned Company;
Black Owned Company (Majority Shareholder) and Non-Black Owned Company;
Black Women Owned Company and Black Owned Company, and;
Black Women Owned (Majority Shareholder) and Non-Black Owned Company.

A 51% or more Black Owned Companies or Joint Venture where the lead company has 51% or more black ownership.

Procurement Preference Hierarchy

Preference for awarding this contract and/or subcontracting is in the following order:

Companies with more than 51% Black Ownership
Enterprises Owned by Black People Living with Disability (BPLwD)
Black Youth Owned Enterprises (BYO)
Black Women-Owned Enterprises (BWO)
Black Owned Enterprises (BO)

Supplier Development & Localisation (SD&L) compliance

The *Contractor* complies with and fulfils the *Contractor's* obligations in respect of the Supplier Development & Localisation in accordance with the matrix and as provided for in the *Contractor's* SD&L matrix stated below:

Skills development

Tenderers are required to submit proposals in a table below for developing the skills of unemployed candidates in the country. Skills development is intended to address Eskom’s core, scarce and critical skills and the scarce and critical skills. These skills are also included in a 2020 list of occupations in high demand as stipulated in the Government Gazette 43937. Candidates shall be from the Kwa Zulu Natal **area**, and their composition shall be representative of the population demographics of South Africa.

Skill type / Occupation	Eskom target
Solar PV Installer Course	1

The *Contractor* shall keep accurate records, that is the implementation schedule of the SD&L targets and provide the *SD&L Advisor/Project Manager* with the implementation schedule on the *Contractor’s* actual delivery against the above stated SD&L criteria. The implementation schedule must be submitted every three months.

The *Contractor’s* failure to comply with his SD&L obligations constitutes substantial failure on the part of the *Contractor* to comply with his obligations under this contract.

The contractor will be expected to comply with other developmental initiatives that may be provided by the SD&L Department during the execution of the contract.

Expanded Public Work Programme (EPWP)

- The *Contractor* must report all local/temporary labourers employed in a project
- The *Contractor* MUST submit a report on a monthly basis
- The *Contractor* must NOT wait until the end of a project in order to submit reports
- The *contractor* must submit the REV 7 report together with the assessment claim for payment.
- The *contractor* is responsible for assisting ESKOM in reporting all work done.
- Eskom’s report feeds back to Parliament and non-reporting of *contractors* affects this report.
- No payment will be certified without the required report being submitted.

i. Lost Time Injury Report (LTIR)

- The *Contractor* must submit this report monthly with each payment assessment claim
- No payment will be certified unless this report is submitted

Subcontracting

Preferred subcontractors

The *Contractor* to submit the names of each proposed subcontractor to the *Employer* for acceptance. The *Contractor* does not appoint a subcontractor until the *Employer* has accepted such subcontractor.

Subcontractor	Section of Work to be Subcontracted	Vendor No.(If Applicable)

Sub-Contracting shall be in accordance to the NEC3 Sub-Contracting Contract.

Subcontract documentation, and assessment of subcontract tenders

The *Contractor* to indicate the proposed subcontractors together with their BBBEE statuses, and the sources of assets, goods or services when local content and production criteria are applicable. The proposed target will form part of the contractual obligation. The NEC system is compulsory for all subcontract documentation.

Subcontracting is mandatory on contracts above R30 million and is a condition for contract award. If feasible tenderers shall subcontract a minimum of 15% of the contract value to the following designated groups:

- an EME or QSE which is at least 51% owned by black people;
- an EME or QSE which is at least 51% owned by black people who are youth;
- an EME or QSE which is at least 51% owned by black people who are women;
- an EME or QSE which is at least 51% owned by black people with disabilities;
- an EME or QSE which is 51% owned by black people living in rural or underdeveloped area or townships;
- a cooperative which is at least 51% owned by black people;
- a EME or QSE which is at least 51% owned by black people who are military veterans

NOTE 1: Tenderers shall submit the following returnables for Subcontracting

- Subcontracting agreement signed by both parties **or**
- Copies of signed letters from the tenderer to the sub-contractors stating the intent to sub-contract
- Subcontractors' Company registration documents
- Subcontractor's valid BBBEE certificate issued by a SANAS accredited verification agency or valid sworn affidavit or valid BBBEE Certificate issued by CIPC for EME companies

Potential scope to be subcontracted and/or outsourced:

- **Not Applicable**

Subcontracting, in this instance, will be treated as a condition for contract award. A supplier awarded a contract may not subcontract more than 25% of the value of the contract to any other entity that does not have an equal or higher B-BBEE status level of a contributor than the supplier concerned unless the contract is subcontracted to an EME that has the capability and ability to execute the subcontract.

Plant and Materials

Quality

The *Contractor* shall control his activities and processes in accordance with Eskom's Quality Requirements for Procurement of Assets, Goods & Services, QM-58 and ISO-9001.

Please note the contractor is accountable for all the material for the Project

Plant & Materials provided "free issue" by the *Employer*

- 5m Wooden poles
- 6mmsq Airdac
- Split meters
- Ready boards

The Dispatch Controller and the Contractor shall sign the Goods Issue Document at collection as a declaration that;

- The quantities are correct as specified on the Good Issue Document
- The quality of material is acceptable
- Any discrepancies found shall be noted in the remarks column and co-signed by the Despatch Controller and the Contractor

Refer to the following link for Standards:

http://tescod.eskom.co.za/prt09BG/BUYERS_GUIDE_3000.htm

http://tescod.eskom.co.za/prt09BG/BUYERS_GUIDE_2000.htm

http://tescod.eskom.co.za/prt09BG/BUYERS_GUIDE_0000.htm

Contractor's procurement of Plant and Materials

All material is to comply with the latest Eskom Power Delivery Engineering-List of Approved products (LAP), and KZN OU approved suppliers / Eastern Cape OU by the Eskom Standards and Implementations Department. All conductors accept ABC and concentric conductor are to carry Eskom Holdings SOC Limited's identification markings. Approval for any non-standard material items shall be obtained from the Standards Implementation Department KZN OU prior to it being used on the project. Contractor to do acceptance sampling on receipt of material on site in order to inspect the outward condition of the material item and whether it is an Eskom approved product.

In exceptional cases which require materials and/or techniques which are not contemplated in the various Distribution standards shall be approved by the provincial Standards Implementation Department. The written approval shall be submitted together with the tender.

The contractor will be required to arrange a material sample inspection on site according to the requirements supplied by the project Engineer. At this inspection materials will be recorded and approved per item by the Project Engineer and the provincial S&I Department.

The *Employer* requires warranties from the *Contractor* to be in favour of the *Employer* and not just to the *Contractor* during the life of the contract.

Spares and consumables

All hardware to be supplied by Contractors is to be as per Eskom Standards limited to Eskom's approval. All hardware and cost thereof shall be within the mandate that has been Eskom approved.

Tests and inspections before delivery

The contractor is required to confirm, that for contractor supplied material, at the time of purchase, materials comply to Eskom specifications and that the relevant test certification is available for inspection and verification.

The *Contractor* will be required to supply the following:

- Material Inspection & Approval by provincial Standards and Implementations Department.
- Plant Data sheets per Transformer area.
- Transformer Earth Resistance Test.
 - Re-closer Earth Resistance Tests.
 - Handovers for each transformer installation.
- Meter Movement form per house connection.

- Compaction Test

The Designer will be required to supply the following:

- Soil resistivity tests
- Suitably designed earth electrodes

Marking Plant and Materials outside the Working Areas

Where applicable. Subject to approval of the Clerk of Works.

Contractor's Equipment (including temporary works).

The *Contractor* is to provide equipment necessary to complete the *Works* safely and by the *completion date*. Prior Approval of the Project Manager is required

Cataloguing requirements by the Contractor

State whether cataloguing is applicable, if it is, reference the requirements for cataloguing that need to be satisfied by the *Contractor* (consult Procurement Instruction Number 1 of 2018 – Incorporating Cataloguing into the Procurement Environment, Unique Identifier 240-1289988974).

Construction

Temporary works, Site services & construction constraints

Employer's Site entry and security control, permits, and Site regulations

4.1.1 Employer's Site entry and security control, permits, and Site regulations

4.1.2 The contractor provides a secure and accessible area for the Site Camp, which includes secure storage facilities and areas, etc. The location of the site camp shall be determined in consultation with the Project Manager, local communities, and the relevant authorities.

On completion of the contract, the contractor removes the site camp and offices, and the area will be left in its original state to the satisfaction of the employer's representative.

Site Establishment Costs

The *Contractor* shall take note that the total cost involved in establishing site services, facilities, and temporary works shall be incorporated in the Activity Schedule.

In situations where private roads must be used for construction purposes, the condition of the said roads shall be recorded (e.g. Photographed) prior to the use thereof and be agreed upon by the *Employer*, the *Landowner* and the *Contractor*. The *Contractor*, at all times at his expense, shall maintain all private roads used as access to the site of work by the *Contractor*. Upon completion of the work the road shall be left in at least the condition it was prior to the commencement of the construction activities.

The Contractor should adhere to the Life Saving Rules at all times.

Due to the importance to safe life's and apparatus of Eskom it is recommended that if a contractor abuse any Life Saving Rules, all work allocated to the contractor will immediately put on hold until final outcome with investigation. Safety is the combined responsibility of the team and therefore team leader or team will be punished together. There are five cardinal rules that may not be broken by the Team Leader and his/her team.

Restrictions to access on Site, roads, walkways and barricades

Where possible, access along the power line must be established by utilizing existing tracks. Access roads shall only be constructed and maintained where necessary at watercourses, steep slopes or where boulders and rocks prohibit vehicular traffic. No access roads shall be constructed in and/or outside the power line servitude without the written instructions from the *Project Manager*

People restrictions on Site; hours of work, conduct and records

Restrictions and hours of work may apply on some Sites. It is very important that the Contractor keeps records of his people on Site, including those of his Subcontractors which the Project Manager or Supervisor have access to at any time. These records may be needed when assessing compensation events

Health and safety facilities on Site

The *Contractor* shall at all times adhere to the **Health & Safety General Specification** attached in the Annexure of the contract document.

Daily safety tailgate talks shall be held to discuss the safety aspects and risks involved in the day's work to ensure safe operation throughout the contract period. A health & safety risk analysis must be completed per outage area scope of work.

The *Contractor* shall **not work on any "live" structure, whether it is MV or LV** without authorisation.

Machinery that can encroach on the safe working clearances with regard to live lines, are not to be operated within nine metres of live reticulation lines, without the direct supervision of a qualified supervisor under the *Employer's* HV Regulations and the OHS Act.

Precautions against Damage

The contractor shall take precautions for the protection of life and property on, or about, or in connection with the contract. The contractor shall be held liable for any damage arising from negligence on the part of himself and his employees. The contractor will ensure that excavations are done carefully as no plans of existing services are normally available of the rural areas. The damages occurring during any required excavations will be for the contractor's risk, and must therefore be repaired by the contractor.

Protection of the environment should at all times be adhered to.

Customer & Client liaison

The contractor will ensure that all required outages be communicated to the *Project Manager* and that the necessary outage requests are tabled for approval at the Monthly Outage meetings of the applicable area.

Environmental controls, fauna & flora, dealing with objects of historical interest

The Contractor shall at all times adhere to the Environmental Management Programme (EMP) and all referenced documents referred to in Section 2.4.

No fences, gates or locks may be damaged to obtain access onto a line route. Arrangements must be made in advance to obtain permission for access.

Use of private roads must be arranged in advance. Any damage to private roads must be repaired at the contractor's expense and to the satisfaction of the landowner.

No fires may be lit on private property. If fires are lit on Eskom's property or in the construction camp, provision must be made that no accidental fires are started. No firewood may be collected in the veld.

No trees may be cut or removed without prior permission from the landowner. Permits shall be obtained for protected trees (protected trees shall be dealt with in special conditions)

Title to materials from demolition and excavation

The *Contractor* has no such title.

Cooperating with and obtaining acceptance of Others

The *Contractor* is responsible to ensure that the landowners and/or local authority have been informed before any work is carried out on site.

Publicity and progress photographs

Photographs can be captured to provide evidence with supporting documentation where applicable. These photographs shall have date and time stamps to be eligible for use.

Contractor's Equipment

The Contractor is to provide equipment and machinery necessary to complete the Works safely and by the completion date. An equipment and Machinery asset register is to be kept on site.

Facilities provided by the *Contractor*

The *Contractor* shall provide on Site a minimum of one well illuminated, insulated and ventilated site office for utilisation by the Employer / Project Manager or their representatives. This site office shall have as a minimum the following:

- Suitable water supply and sanitary facilities (chemical toilet).
- Telecommunication facilities (down loading of electronic communications and printing of it) e.g.: Fax, Telephone/Cell phone facilities.
- Access to Eskom website to download latest information.
- 1 x Table, 6 x chairs and drawing/filing cabinet.
- Site diary
- The *Contractor* provides an area for the construction offices, stores, yards, etc. to the approval of the Employer's Agent In addition, the *Contractor* shall make available a desk to be used by Employer's Agent / Employer's Representative.
- The *Contractor* erects a 1,8m fence around his construction site and fits a lockable gate
- The *Contractor* provides a construction supply at their site camp and anywhere else as may be required
- The *Contractor* provides the necessary connecting cables and distribution board(s) from the electricity supply source to the points of demand. The *Contractor* provides all the necessary connection to the electricity supply and maintains and secures all cable, etc.
- The *Contractor* is to provide all necessary water and sewage connections
- The *Contractor* provides facilities and resources for first aid, firefighting and emergency repair services in accordance with the Occupational Health and Safety Act and the local authority regulations and requirements.

Existing premises, inspection of adjoining properties and checking work of Others

To be negotiated and agreed with the approval of the community liaison officer where applicable

Excavations and associated water control

No excavations should be left open or unattended. If the *Contractor* encounters any rock during excavation, he/she must inform the Clerk of Works first to come and verify before he/she can use a mechanical boring device, drilling or blasting and requires the approval of associated costs from the Quantity Surveyor.

Underground services, other existing services, cable and pipe trenches and covers

The *Contractor* shall be held liable for any damages caused during construction to existing services such as, underground water pipes, electrical cables, telecommunication cables, overhead lines, storm water pipes and existing roads.

It is the responsibility of the *Contractor* to contact the landowner and/or local authority to determine the position of such services to prevent any damages.

Control of noise, dust, water and waste

The *Contractor* shall within reason try and keep noise levels, dust and wastage to a minimum

Sequences of construction or installation

As per the approved construction programme and in conjunction with the Quality Control Plan

Giving notice of work to be covered up

The Project Manager/Clerk of Works shall always be notified

Hook ups to existing works

All safety requirements shall be observed

Completion, testing, commissioning and correction of Defects

Work to be done by the Completion Date

On or before the Completion Date the *Contractor* shall have done everything required to Provide the Works except for the work listed below which may be done after the Completion Date but in any case before the dates stated. The *Project Manager* cannot certify Completion until all the work except that listed below has been done and is also free of Defects which would have, in his opinion, prevented the *Employer* from using the *works* and Others from doing their work.

	Item of work	To be completed by
	As built drawings of	Within days after Completion
	Performance testing of the <i>works</i> in use as specified in paragraph of this Works Information.	See performance testing requirements.

The whole of the *Works* as described by the *Works Information* of this contract and in the Final Design package shall be completed on or before the *Completion Date*. Completion includes the completion and submission of hand-over documentation, as-built drawings, and completed defect lists. The *Contractor* pays delay damages for late completion in terms of the *Conditions of Contract*. Should the Contractor receive 3 non-conformances, preventative actions and corrective actions, Eskom reserves the right to terminate the Contract.

Materials facilities and samples for tests and inspections

State what materials facilities and samples for tests and inspections the *Contractor* and the *Employer* are to provide, per core clause 40.2.

Commissioning

Required mainly for contracts including mechanical and electrical work. Would typically refer to detailed commissioning procedure attached as an Annexure. Confirm whether commissioning is to be done before or after Completion. If after Completion, include this item of work in the list in sub-paragraph 0 above.

Start-up procedures required to put the *works* into operation

Where applicable, arrangements shall be made with the relevant departments within Eskom

Take over procedures

Take-over is after or at the same time as Completion. The *Contractor* is to arrange an inspection before completion of the installation to inspect and identify any outstanding or any defects. The *Project Manager* may require the *Contractor* to provide assistance, on an as and when required basis

Access given by the *Employer* for correction of Defects

The *Project Manager* arranges access for the *Contractor* to use a part of the *works* which has been taken over if needed to correct any Defects. After the *works* have been put into operation, the *Employer* may require the *Contractor* to undertake certain procedures before such access can be granted. The *Contractor* will be responsible for ensuring that the area to be worked in is barricaded before correcting any defects.

Performance tests after Completion

The *Contractor* will perform all tests required to bring the asset to service

Training and technology transfer

The *Contractor* may be required to provide training of Eskom employees, such arrangement will be made where applicable.

Operational maintenance after Completion

The *Employer* may require the *Contractor* before the *defects date* to perform certain duties after Completion and take over which relate to maintenance of the *works*.

Plant and Materials standards and workmanship

This section of the Works Information contains all the specifications for the work which is left behind; the permanent works. It is likely to be the largest section by far and may even be compiled in volumes, e. g. Section 6 Volume 1: Civil Engineering Works. In design and construct contracts, it may be compiled in accordance with systems within the *works*; e. g. Section 6 Volume 4: Crushers.

Because practice varies widely between employers it is not practical in a general template such as this to deal with all arrangements. Only the discipline based section subheadings are provided below in the order the *works* are likely to be constructed together with some notes of a general nature.

Investigation, survey and Site clearance

Some contracts may require the *Contractor* to carry out further investigation of existing facilities or of the Site before commencing final design. There could be constraints on Site clearance especially in pipeline or transmission grid servitudes.

Building works

Reference could be made to the latest Model Trade Preambles published by the Association of South African Quantity Surveyors. However these have been developed for use with the JBCC series of contracts and an approach where description of the work is made part of the bill of quantities, which is not the case in other forms of contract. Only parts of the Model Trade Preambles could be referenced by an ECC contract, with a covering note dealing with the changes in terminology. Further changes are required depending on which parts are to be selected.

This subsection would typically comprise

- a) Particular specifications provided by the *Employer*
- b) List of standardised specifications applicable to the *works* and
- c) Variations to the standardised specifications

Civil engineering and structural works

Reference could be made to the SANS1200 series of specifications developed and published by South African National Standards. However these are now very out of date and originally developed for use with SAICE general conditions of contract for works of civil engineering which have themselves been superseded twice.

All SANS 1200 specifications are in the process of being updated to make them more compatible with a wider range of contracts, including NEC, and users should check availability of the new SANS 2000 series of specifications.

Sections 3, 4 and 5 of SANS1200A are probably already covered in section 5 of this Works Information.

This subsection would typically comprise

- a) Particular specifications provided by the *Employer*
- b) List of standardised specifications applicable to the *works* and
- c) Variations to the standardised specifications

If use is made of the 1200 series, users should include a covering note dealing with the changes in terminology, such as the one provided below. Further changes are required depending on which specifications in the 1200 series are selected.

C3.2 CONTRACTOR'S WORKS INFORMATION

This section of the Works Information will always be contract specific depending on the nature of the *works*. It is most likely to be required for design and construct contracts where the tendering contractor will have proposed specifications and schedules for items of Plant and Materials and workmanship, which once accepted by the *Employer* prior to award of contract now become obligations of the *Contractor* per core clause 20.1.

Typical sub headings could be

- a) *Contractor's* design
- b) Plant and Materials specifications and schedules
- c) Other

This section could also be compiled as a separate file.

PART 4: SITE INFORMATION

Document reference	Title	No of pages
C4	This cover page Site Information	1
	Total number of pages	

PART 4: SITE INFORMATION

Core clause 11.2(16) states

“Site Information is information which

- describes the Site and its surroundings and
- is in the documents which the Contract Data states it is in.”

In Contract Data, reference has been made to this Part 4 of the contract for the location of Site Information.

The DD as well as the geographical layout is included below.

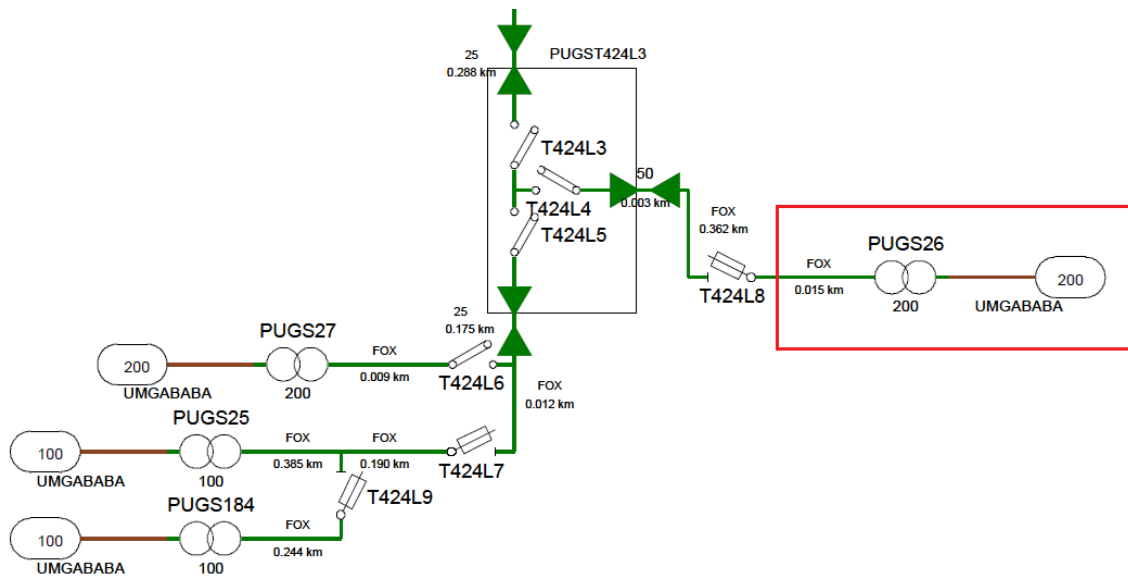

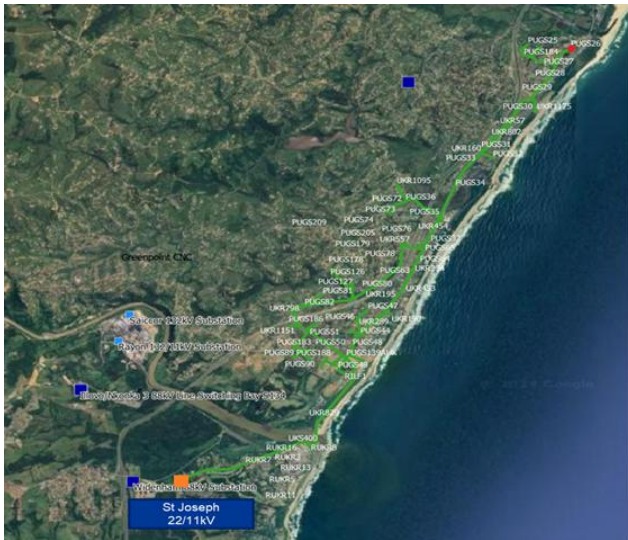

- ◆ PUGS26
- St Joseph Substation 22/11kV