

	Standard	National Transmission Company South Africa
---	-----------------	---

Title: TECHNICAL STANDARD FOR PERMANENTLY FIXED AND PORTABLE GAS ANALYSER FOR APPLICATION IN POWER TRANSFORMERS AND REACTORS

Document Identifier: **240-64917195**
 Alternative Reference Number: **N/A**
 Area of Applicability: **Eskom**
 Functional Area: **Engineering**
 Revision: **2**
 Total Pages: **46**
 Next Review Date: **February 2030**
 Disclosure Classification: **Controlled Disclosure**

<p>Compiled by</p>  <p>Sanele Miya Engineer: - Transformers and Reactors</p> <p>Date: 20/02/2025</p>	<p>Approved by</p>  <p>Sidwell Mtetwa Corporate Specialist: - Transformers and Reactors</p> <p>Date: 20/02/2025</p>	<p>Authorized by</p>  <p>Bheki Ntshangase Senior Manager: - SE&D</p> <p>Date: 20/02/2025</p>
---	--	---

	<p>Supported by SCOT/SC</p>  <p>Bheki Ntshangase: - SCOT PE TC Chairperson</p> <p>Date: 20/02/2025</p>
--	---

Content

Page

1. Introduction.....	4
2. Supporting Clauses	4
2.1 Scope.....	4
2.1.1 Purpose.....	4
2.1.2 Applicability	4
2.2 Normative/Informative References	4
2.2.1 Normative.....	4
2.2.2 Informative.....	5
2.3 Definitions	5
2.4 Abbreviations	5
2.5 Roles and Responsibilities	6
2.6 Process for Monitoring.....	6
2.7 Related/Supporting Documents.....	6
3. Requirements	6
3.1 Basic Requirements	6
3.1.1 Permanent fixed Online DGA	6
3.1.2 Portable DGA	7
3.2 Self - Calibration.....	7
3.3 Outputs	7
3.4 Solution and Communication Architecture	9
3.5 Software for Device Configuration	10
3.6 External Sensor Inputs	10
3.7 Enclosure and Electrical Terminations.....	11
3.8 Communication Medium and Hardware.....	12
3.9 Oil Interface.....	15
3.10 Application.....	16
3.11 Environmental, Electrical and Mechanical Requirements	16
3.11.1 Site Condition	16
3.11.2 Electrical.....	17
3.11.3 Power Supply	17
3.11.4 Mechanical Shock and Vibration.....	17
3.12 Safety Compliance	18
3.13 Technical Specifications	18
4. Scope of Supply	18
5. General	19
6. Implementation	20
6.1 Specific Tasks and Responsibilities of the Contractor.....	20
6.2 Quality Control.....	21

CONTROLLED DISCLOSURE

7. Service Life and Life Cycle Costing	21
8. Supportability and Maintainability	22
8.1 Reliability, Availability and Maintainability (RAM Programme)	22
8.2 Maintenance Philosophy	22
9. Training	22
10. Documentation	23
11. Acceptance.....	24
12. Revisions.....	24
13. Development Team	24
14. Acknowledgements	24
Annex A.....	25
Annex B.....	44

Figures

Figure 1: Data Acquisition Architecture	10
Figure 2: Typical layout and cabling of analyser, transformer patch panel and control room patch panel for a three-phase transformer.....	14
Figure 3: Typical layout and cabling of analyser, transformer patch panel and control room patch panel for three single phase transformers. This layout would also be used when power transformers are within 10 metres to one-another.....	15

Tables

Table 1: Requirements for relays used for alarms	9
Table 2: The minimum specific requirements of fault gas and moisture detection	18

CONTROLLED DISCLOSURE

1. Introduction

This standard describes the requirement for a system that shall continuously, automatically monitor and provide indication of fault gases dissolved in transformer oil, while the transformer is in service. It may be based on the headspace or carrier gas principles. The system shall also provide a continuous indication of dissolved water in the oil. The system shall provide local and remote indication of the measured parameters, trend the data and be able to provide alarm indications locally and remotely (through SCADA and via software).

This specification covers multi-gas (minimum 8 gas; insulating oil fault gases) with moisture monitoring systems; the specific schedule where the requirements are tabled and where the vendor will indicate what they can offer appears in the AB Schedules, A schedule is Eskom's specific requirement and B schedule is the suppliers offer, in Annexure A (permanently fixed DGA) & in Annexure B (portable DGA).

2. Supporting Clauses

2.1 Scope

This specification details the requirements for an permanently fixed online and portable dissolved gas analyser system including the supply, installation, testing and commissioning of the gas analyser, its required supporting hardware and software for presentation of data and transformer condition, communicating software as well as pipework connections to the oil interface of the transformer and connections to other sensors and peripherals. The analyser should have on board intelligence which evaluates transformer condition. This standard shall cater for all transformer online gas analyser-based systems to be used throughout Eskom. The analyser must be able to operate in mineral oil, natural and synthetic ester, and silicon mediums.

2.1.1 Purpose

The purpose of this document is to outline the requirements for the supply, installation, testing, commissioning and training of the gas analyser devices and accompanying system in Eskom/NTCSA for use in the substation and power station environments.

2.1.2 Applicability

This document shall apply throughout Eskom/NTCSA Holdings Limited Divisions / National Transmission Company South Africa SOC Ltd Reg No 2021/539129/30.

2.2 Normative/Informative References

Parties using this document shall apply the most recent edition of the documents listed in the following paragraphs.

2.2.1 Normative

- [1] IEEE 1613-2009 - IEEE Standard for environmental and testing requirements for communications networking devices installed in electric power substations.

CONTROLLED DISCLOSURE

- [2] IEC 61850 Ed 1 - Parts 1-14, Standard for Communication networks and systems in substations
- [3] IEC 61850-7 - Basic communication structure for substation and feeder equipment
- [4] IEC 61850-8-1 - Mappings to MMS (ISO/IEC9506-1 and ISO/IEC 9506-2) - Ed.2
- [5] IEC TS 61000-6-5:2001 - Electromagnetic compatibility (EMC) Part 6-5: Generic standards. Immunity for power station and substation environments
- [6] IEC 60721-3-3 Classification of environmental conditions
- [7] IEC 60296 - Mineral Insulating oils for transformers & switchgear
- [8] IEC 60599 - Mineral oil impregnated electrical equipment in service, guide to the interpretation of dissolved and free gas analysis.
- [9] IEC 60567 - Oil filled equipment – sampling of gases and analysis of free and dissolved gases

2.2.2 Informative

None

2.3 Definitions

2.4 Abbreviations

Abbreviation	Explanation
APN	Access Point Name
CSD	Circuit Switched Data
CT	Current Transformer
DGA	Dissolved Gas Analysis
DNP3	Distributed Network Protocol
EDGE	Enhanced Data Rates for GSM Evolution
EMI	Electromagnetic Interference
CSD	Circuit Switched Data
CT	Current Transformer
FTP	File Transfer Protocol
GaAs	Gallium Arsenide
GPRS	General Packet Radio Service
GSM	Global System for Mobile Communications
GUI	Graphical User Interface
HDPE	High Density Polyethylene
HTTP	Hyper Text Transfer Protocol
IP(56)	Ingress Protection
IP	Internet Protocol
ITP	Inspection and Test Plan
LCD	Liquid Crystal Display

CONTROLLED DISCLOSURE

Abbreviation	Explanation
LED	Light Emitting Diode
Mbps	Mega Bits Per Second
MM	Multi-Mode
MMS (IEC61850)	Manufacturing Message Specification
NTCSA	National Transmission Company of South Africa
NTP	Network Time
PQP	Production Quality Plan
PSTN	Public Switched Telephone Network
PTM&C	Protection Telecommunications Metering and Control
PVC	Polyvinyl Chloride

2.5 Roles and Responsibilities

The relevant SCOT Care Group chairpersons shall ensure that this document is kept valid and relevant.

2.6 Process for Monitoring

This document shall undergo formal review process, and its validity shall be tracked through the official document management system.

2.7 Related/Supporting Documents

Not applicable.

3. Requirements

3.1 Basic Requirements

3.1.1 Permanent fixed Online DGA

The basic functional requirements of the system are that it shall be self-contained, field robust and measure more than 6 fault gases (as specified by the AB schedules in Annexure A) and dissolved water in the oil of a transformer and indicate this locally and remotely via IEC 61850 communication protocol (as defined in section 3.4 below). The system shall provide a continuous (on-line) monitoring function with automatic data acquisition (and pushing of data see section 3.3 - 3.4) with a user identified option of reducing the data collection period to hourly levels. On-board data storage of the system shall be more than one year at the highest sample rate. The system should contain on board intelligence capable of analysis and triggering of alarms for fault conditions both against set alarm thresholds and against international standards, see 4.2.6. The facility to include other inputs (such as transformer load current measured via an external CT, transformer oil temperature and ambient air temperature) shall be provided by the system.

CONTROLLED DISCLOSURE

3.1.2 Portable DGA

The portable gas analyser must deliver accurate, reliable, and on-the-spot oil analysis results. It must be compatible with both mineral insulating oils and newer ester-based fluids (natural and synthetic). A thermal printer should be integrated into the product design, allowing the operator to produce hard copy records of all tested samples. Additionally, the product must feature an HMI touchscreen interface and include internal storage capacity for record-keeping. A USB connection is required to enable communication with an external computer, allowing databases to be downloaded to a PC. The device must be portable and weigh no more than 9kg.

3.2 Self - Calibration

While Eskom/NTCSA is not prescriptive of the gas separation and indication techniques employed, some form of self-calibration or verification facility for gas and moisture shall be included as an integral part of the system. This shall be against the accuracies and repeatability required by this standard set out in **Table 2**. In addition, there shall be some form of self-diagnostics integral to the system, which shall flag through a service alarm (through a SCADA alarm and on an LED indicator as well as internally in the software logs) any analyser system error or malfunction, see section 3.2 below.

3.3 Outputs

The analyser is to output certain (defined below) alarm states as well as detailed gas data for analysis. The gas and monitoring data will be stored and monitored based with a solution architecture in line with the standard 240-64038621 Remote Device Communication Standard for Data Retrieval and Remote Access.

The states and alarm notifications shall be discussed herein:

The main states that the analyser shall have, to be used for alarming and notifications are:

1. **Analyser Normal state (Green)**, the analyser is powered up correctly and all self-diagnosis parameters are within limits and gas data is valid and within limits.
2. **Analyser Service Notification (Blue)** – The analyser itself is producing results that are compromised and void based on its internal diagnostics and verification. Servicing and maintenance attention is required.
3. **Gassing Caution Notification (Orange)** - The analyser is in a caution state in terms of analyser results as per setup criteria. See section 3.2.6 below.
4. **Gassing Alarm Notification (Red)** – The analyser is in an alarm state in terms of analyser results as per setup criteria. See section 3.2.6 below.

These main states/notifications shall be communicated to users by the following means:

3.2.1 LED colour indicators on the device, to be clearly visible in daylight, indicating the above four states by means of defined colours as above.

CONTROLLED DISCLOSURE

3.2.2 SCADA alarms are to be implemented using one of the required protocols the device must support (as defined in the AB schedules, to alarm for points 1 to 4). These are to be implemented in line with the architecture in section 3.3. Normally, alarms shall be sent from the device over IEC 61850 MMS server to the station SCADA gateway or data concentrator. In the case where a data concentrator or gateway is not used then alarming via IEC 101 or DNP 3.0 protocols shall be used. From the Eskom/NTCSA SCADA SMS and email notifications will be generated from the central SCADA system to the necessary field engineers, and operators. The gassing notifications shall include the gas concentration value that is being exceeded as well as the previous measurement value, see section 3.2.6 below. The service notification shall include a high-level description of the malfunction, the service logs of the device would then be accessed thereafter following such a notification for diagnostic purposes.

3.2.3 SCADA alarms implemented by relays as discussed in 3.2.7 below for notification points 1 to 4 must also be included.

3.2.4 Direct SMS notifications (to at least two Eskom/NTCSA personnel to be user defined) from the device by means of a GSM modem shall also always be operational in case reporting via SCADA is not available for a specific installation. These notifications must include the gas concentration value that is being exceeded as well as the previous measurement values of all 8 gases. See section 3.2.6 below. They must also provide detailed error codes in the case of reporting device failures/service errors.

3.2.5 Local indication shall consist of an LCD screen on the device where the concentrations of gas and moisture as well as other external inputs can be viewed and graphed. The alarm states and accompanying gas concentration shall be flagged appropriately on the GUI.

The remote indication of data shall be implemented with the solution architecture as described in section 3.3-3.4 and 240-64038621. Remote data indication shall be possible using standard protocols interfacing with Eskom/NTCSA wide tools for analysis and presentation. Within the data Registers of the analyser when an alarm threshold is breached it should flag which gas and what corresponding value triggered an alarm for easy tracking.

3.2.6 Gas Alarming

Section 3.2 has stated that notifications and alarms for gassing are central to the gas analyser system.

The alarm levels would be user defined and operate in the ranges and accuracies (and repeatability) as defined in Table 2: The minimum specific requirements of fault gas and moisture detection. A caution and alarm notification shall be configured based on two certain concentration values and/or certain user defined rate of changes.

The rate of change must be configurable in terms of average increase over a number of days i.e. line of best fit calculation.

The actual levels and rate of changes (the user configured ones) shall be defined by Eskom/NTCSA using an alarm setting sheet for each analyser.

The caution and alarms should also be triggered by on board intelligence against international norms alongside those triggered by user defined alarm levels. Thus a 'caution' or 'alarm' should either be from a user set parameter or an on-board intelligent parameter.

System reliability depends heavily on the reliability of voltage transformers. Breakdowns of this equipment prevent information flow to protective relays, leaving the power system unprotected. Thus, this equipment must withstand all types of system conditions including transient over-voltages and harmonics.

3.2.7 Relay Outputs

CONTROLLED DISCLOSURE

As mentioned in section 3.2.3 the analyser must have potential free digital relay outputs for alarms to interface to the SCADA system which shall have four relays for the four states as defined in section 4.2. The relays shall be specified as detailed in Schedule AB and conforming to the requirements of ESP 32-333 and **Table 1** below.

Table 1: Requirements for relays used for alarms

Make and carry current	1 A @ 250dc
Carry Continuously	1 A
Break (Inductive L/R=40ms)	10 W @ 250 V dc

3.2.7.1 The analyser device shall contain spring loaded terminal blocks to facilitate all copper wire interfaces between the analysers and PTM+C plant. See section 3.7.

3.2.7.2 The contact and input ratings must be capable of switching 110/220 V dc without modification.

3.2.7.3 All cabling to enable SCADA Alarm connections from the system to the transformer marshalling kiosk or if required to the local control room shall be provided by the Vendor.

3.2.7.4 Only UV stable, heat- and oil-resistant PVC SWA (Steel Wire Armouring) cable shall be used. Only corrosion resistant cable glands for armoured cables shall be used. Plastic compression type cable glands shall not be used on armoured cables. Heat, oil and UV resistant cable shrouds shall be fitted to all cable glands.

3.2.7.5 All cable terminations shall be provided with cable numbers fitted to the cables on both ends. Only permanently engraved, non-corrodible, UV, oil- and heat-resistant material shall be used for cable numbering. These labels shall be permanently fixed to the cable ends just before the glands on the outside of the terminal box.

3.2.8 Cable Labelling

All labelling and markings shall be permanently engraved labels. The colour of the labels shall be silver with black lettering. The labels shall be manufactured from UV stabilised PVC that is oil and heat resistant. Stamped copper labels are preferred. Labels must be attached to cables with stainless steel cable-ties.

3.4 Solution and Communication Architecture

The data acquisition architecture shall align with the Eskom/NTCSA smart grid strategy and is detailed in the Eskom/NTCSA standard **240-64038621** Remote Device Communication Standard for Data Retrieval and Remote Access. The Analyser's communication philosophy shall conform to the requirements of 240-64038621, for which the role-based access shall be in line with that of the architecture displayed in Figure 1. Notwithstanding the AB schedules in annexure A list the protocols that shall be supported.

CONTROLLED DISCLOSURE

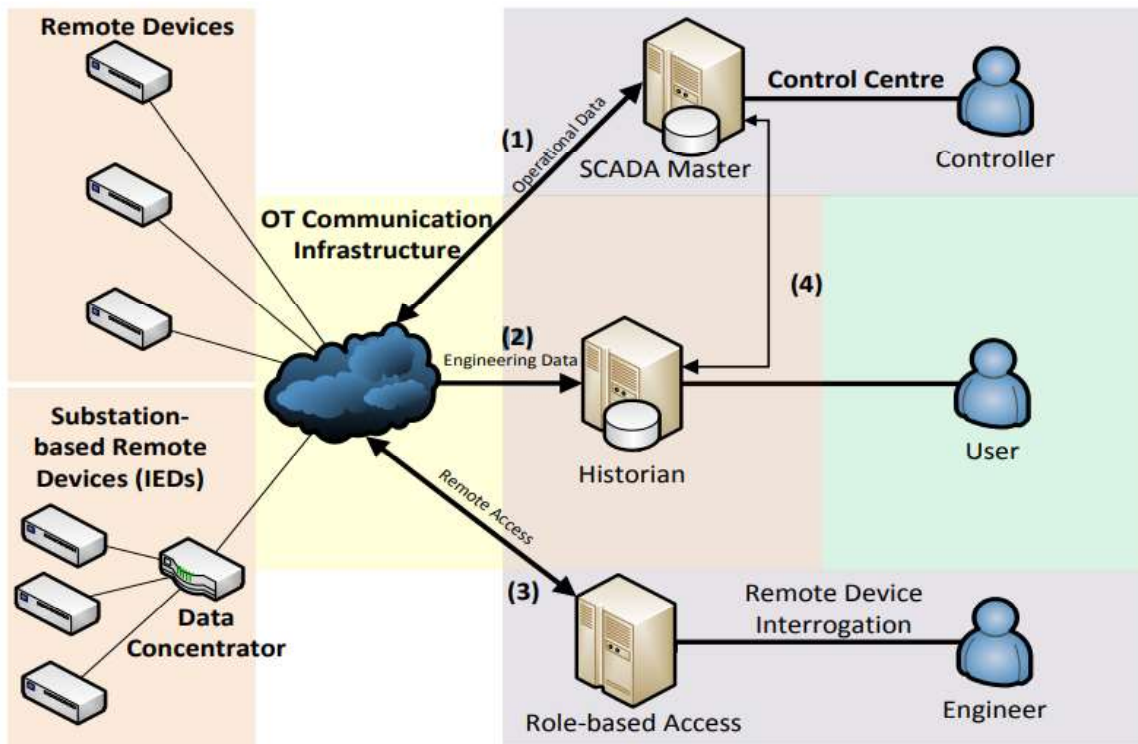

Figure 1: Data Acquisition Architecture

3.5 Software for Device Configuration

The required communication architecture as described by Section 3.3 and the standard 240-64038621 results in the availability of all the devices registers and thus the gas and sensor data shall be available to be used and analysis software packages.

Notwithstanding, software shall be provided detailed configuration (setting of alarms, sampling frequencies) and diagnostics of the analyser. It is preferred that the remote configuration of the device shall also be possible using a native web-interface running on the Analyser, this allows configuration of the device through HTTP/S protocols and would not require proprietary software for configuration of the device. The configuration in either case would only occur from one central secure location within the Eskom/NTCSA network by dedicated controllers to conform to Information Management security requirements.

3.6 External Sensor Inputs

3.5.1 A clip on Load CT, if requested, to measure the load on the transformers in question must be provided with the installation and must interface directly with the analyser. This must be fitted to the LV side white phase.

CONTROLLED DISCLOSURE

3.5.2 Many of Eskom's power transformers and reactors contain fibre optic hot spot temperature probes within the winding. It is required, as an option, that these signals can be input directly to the analyser and integrate with its data registers as required. At present two technologies are used namely Neoptix Gas based probes and Lumasense (Luxtron) Fluoroptic technology-based probes. It is required that an option must be available to order a signal conditioner (which is installed within the same system and fully integrated internally) with the analyser (2 channels to be used on the 2 hottest temperature probes from the winding see Schedule AB) for either probe type which includes the supply and installation of the suitable extension cables from the probes termination at the power transformer.

3.5.3 It is required that the analysers have the provision to interface an oil temperature probe signal to it, and for this signal to be integrated in its data registers accordingly. The temperature probe shall connect via a 4 – 20 mA connection. Connection to RTU must also be possible. Although the probe itself would not be supplied by the Vendor the option for it to be wired and connected to the analyser as part of installation and commissioning must be offered.

3.5.4 Eskom/NTCSA has its own internally developed partial discharge detection equipment. The output of this equipment will normally be over IP format. It shall be an option to integrate this detector into the analyser. This shall interface physically by RJ45 100BaseTX or LC MM 100BaseFX connection with the analysers network switch, see schedule AB in Annexure A.

3.5.5 It shall be possible to use the analyser as a central data marshalling point for data from other transformer condition monitoring equipment and be integrated etc. also using IP format via one of the spare network ports as specified in the AB schedule.

3.5.6 To cater for miscellaneous and future sensor integration with the device the analyser board must come with a number of spare analogue 4 - 20 mA terminals as well as spare RS485 serial interfaces, the required numbers of each spare terminal are specified in the AB schedule. The intention would be for other sensors data to be appended on the data registers of the analyser.

In the AB schedule the exact particulars of interface from external sensors are tabled for the above clauses.

3.7 Enclosure and Electrical Terminations

3.6.1 The entire system shall be contained in a weather-proof, corrosion resistant enclosure with a minimum of IP56 rating with a peaked roof. It is required that the system be mounted on an independent corrosion resistant stand, which is permanently bolted to the concrete plinth around the transformer. The system shall be firmly bolted with stainless steel bolts to the stand. The enclosure, stand, pipe work, fasteners, valves, and conduits are to be manufactured from Stainless Steel (Grade 316).

3.6.2 Sun or heatshields that are firmly affixed to the system are required.

3.6.3 A suitable water-tight and weather resistant electrical-conduit threaded cable entry shall be provided. These shall further be protected by rubber sleeves. Unless otherwise specified, cables, including optic fibre cables, shall enter the system from vertically below. Where cable stands are provided, these shall be equipped with suitable corrosion proof cable saddles vertically aligned with the cable gland positions on the system and spaced to suit the cable manufacturer's recommendations.

3.6.4 The stand is to be firm and be earthed with a rigid earth that has been treated for corrosion and permanently connected to the station earth mat.

CONTROLLED DISCLOSURE

3.6.5 A separate cabinet to be used to house a local fibre optic patch panel for the gas analyser(s) adjacent to a three phase or set of single-phase transformers (which are in proximity) must be provided as an option. This must be used for the termination and interface between fibre optic cables destined to the transformer gas analyser(s) from the control room. This cabinet must be rated IP56 and be affixed on a stainless steel 316 stand adjacent to the analyser in question and have a peaked roof. This cabinet and patch panels within must be suitably sized to interface with the prescribed number of interfaces as per schedules AB in Annexures A. All fibre optic interfaces will be with LC connectors. See section 3.7 below for the details of the fibre optic interfaces.

3.6.6 A rail mounted screw clamp/spring loaded insertion type terminal block suitable for the reception of hooked blade type wiring lugs shall be provided. The terminal blocks shall be of the type which compresses the terminations between two plates by means of terminal screws. Terminals shall also be spring loaded such that the action of the spring is independent of the action of the terminal screw.

3.6.7 Terminal screws shall be captive within the mouldings and the heads shall not project above the moulding when fully released. Each terminal shall accept up to two hooked blade type terminations. Terminal entries shall be shrouded such that no current carrying metal is exposed when hooked blade terminations are fitted.

3.6.8 All terminals and connectors shall comply with the specifications and international standards as detailed in Eskom/NTCSA Specification: EST32-333 (Standard for Electronic Protection and Fault Monitoring Equipment for Power Systems).

3.6.9 All terminals and cables are to be clearly labelled in the system and on corresponding drawings and diagrams. Cables may not enter the system cabinet from the top or side, as bottom entry is required.

3.8 Communication Medium and Hardware

The primary data connection will be made through Fibre optic cable and accompanying network switches. The specification 240-46264031 (Fibre-Optic Design standard – Part 2: Substations) and 240-46263618 (Labelling of Fibre-optic cables) must be adhered to where applicable.

3.7.1 100BaseTx and 100BaseFX (Multimode) support for Ethernet interface is required for the main communication ports. The Fibre ports shall have LC connectors, and 2 channels shall be available. RJ45 Copper interfaces shall also be available (2 channels) to be used as alternatives for networking connections. The Ethernet ports may also be used to input other devices that communicate with Ethernet (see section 3.5) (see schedules AB in Annexure A for specific requirements). The networking switch must meet all requirements of IEC 61850 and IEEE 1613.

3.7.2 The cabling infrastructure between the analyser unit and the control room (for interface with the data concentrator or main network switch in control room) shall be the responsibility of the vendor at the request of Eskom/NTCSA for any installation.

This shall include:

- The Fibre optic switch within the analyser system as described in 3.7.1 (this shall be standard with all analysers).
- The supply and installation of all the required the Fibre optic cable (Heavy Duty Duct cable in HDPE duct, 50/125 um), conforming to specification 240-46264031, with number of cores as required in the AB schedules.
- The laying of the cable in the cable trenches and suitable cable paths between the control room and the transformer bay(s).

CONTROLLED DISCLOSURE

- The installation and wiring of a suitable patch panel and cabinet, as in 3.6.5 (mounted on stainless steel 316L stand and in IP56 cabinet with a peaked roof) in the near vicinity of the analyser unit(s) to be connected and the splicing of the cables with suitable multimode LC connectors.
- Termination of all Fibre optic cables on the transformer gas analyser and transformer monitoring marshalling panel side in control room.
- The cabling of each analyser's switch to the transformer patch panel with LC connectors on either side.
- The termination of the Fibre optic cable in the control room in a patch panel terminating with LC connectors.

The philosophy of the Fibre optic cabling and connections between the analysers is as follows:

In a substation environment there are instances where a number of gas analysers might be in proximity with one-another. This is common in single phase transformer units. Thus, the cabling shall consist of a multi-core Fibre cable to a patch panel, which shall be housed in a cabinet adjacent to one of the analysers, centrally located. From there smaller core cables would be cabled from the patch panel to the other analysers. In addition, spare Fibre cores and interfaces need to be provisioned for other equipment and chance for addition of other analysers in the future.

There are two typical cases of this:

- Three phase transformers

As shown in figure 2, the most common setup would be a three-phase transformer with one analyser. This would require a patch panel for interfacing the Fibre cables. This patch panel would be placed adjacent to the analyser and provide spare LC connectors (see Schedule AB in annexure A) for other equipment or future analysers as well.

CONTROLLED DISCLOSURE

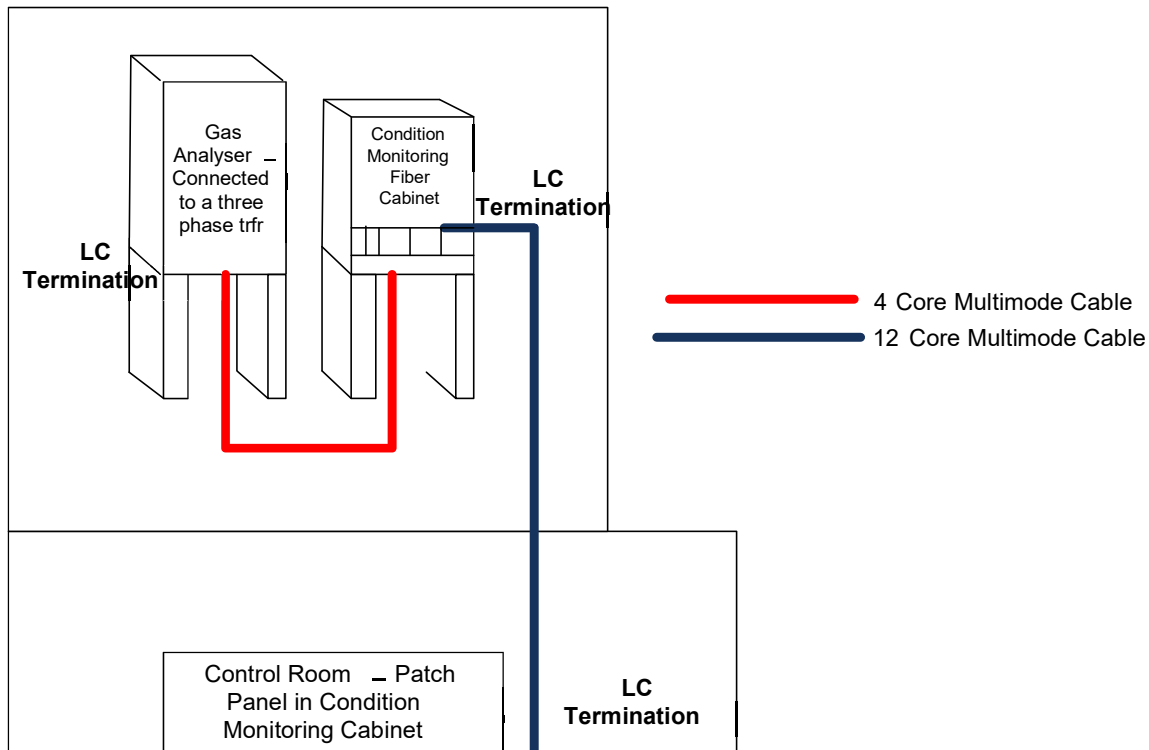

Figure 2: Typical layout and cabling of analyser, transformer patch panel and control room patch panel for a three-phase transformer.

- 3 x single phase transformers

The other case is three single phase transformers adjacent to one another this would consist of three analysers. Thus, as shown in figure 3 below only the central analyser would have a fibre optic patch panel, and the others would connect via that interface point. See schedule AB for the number of interfaces.

Spare cores are provisioned as standard for the possibility of future equipment at the transformer bays as well as for redundancy. The number of cores for the fibre cables is as per figure 2 and 3 unless otherwise specified on AB schedule.

CONTROLLED DISCLOSURE

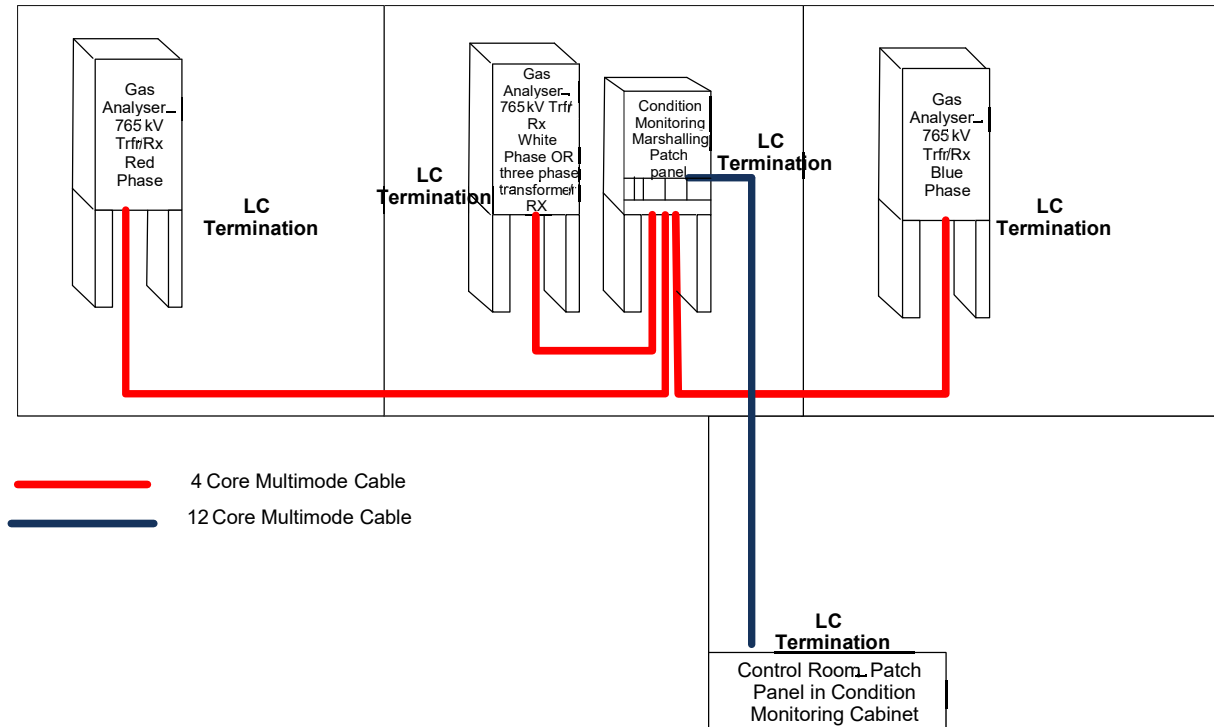

Figure 3: Typical layout and cabling of analyser, transformer patch panel and control room patch panel for three single phase transformers. This layout would also be used when power transformers are within 10 metres to one-another.

3.7.3 The Fibre optic system, switches and cables shall be multimode 50/125 um, this assumes a networking speed of 100Mbps. As a result, as detailed in the AB schedule, multimode equipment must be standard.

3.7.4 The capability to locally (manually) download data from the online DGA via a universal serial bus (USB) port, using Microsoft Excel or CSV file formats without any encryptions and must be password protected.

3.7.5 The analyser shall also offer Telephone line (PSTN) and GSM Circuit Switched Data (CSD) as well as GPRS/EDGE (fully compatible with APN solutions) modem connectivity to be used as alternative and legacy connection mediums.

3.7.6 All external wiring to the system except fibre optic cables which must be in an HDPE duct as per specification 240-46264031, shall be installed in galvanised steel conduit which is firmly affixed to the ground or wall surfaces of the surrounding civil structures.

3.9 Oil Interface

3.8.1 The system shall be provided with oil from the transformer via standard valves, which may be provided by Eskom/NTCSA on most of its transformers. Where these valves are not pre-installed, the Vendor shall make provision for these which must be stainless steel 316L T-pieces with flange dimensions the same as the transformer interface point and a flange-to-flange distance of 100mm must be maintained. In those cases, these must be submitted for evaluation and approval by Eskom. Systems with continuous oil flow from the transformer, through the system and returned to the transformer are preferred.

CONTROLLED DISCLOSURE

3.8.2 The vendor must provide acceptable pipe fittings and flanges such that adequate support and bracing is available for connecting pipes oriented vertically adjacent to tank or part of the transformer.

3.8.3 Transformer oil take-off and return may be via 50 mm or 25 mm diameter double-flange valves situated on the transformer. The standard oil sampling points on the transformer shall not be dispensed with.

3.8.4 An additional oil sampling point, as close as possible to the analyser, shall be provided on the incoming oil line to the monitoring system.

3.8.5 The analyser should be able to detect oil leaks within its oil circuit valves and alarm accordingly.

3.8.6 It is preferable that oil for the monitoring system be obtained as high up on the main transformer tank as possible and an available valve be used for this purpose, where practical. Oil from a cooling loop valve is also acceptable as the input to the system. A modified flange on the main drain valve of the transformer is preferred as the return port for oil from the system back to the transformer. A means of eliminating any air-in-oil return to the transformer is compulsory, for use especially during commissioning of the system. The supplier must train Eskom/NTCSA staff on this item.

3.8.7 The return oil to the transformer shall not be contaminated in any way, this include pumping any air into the transformer. Suitable in-line oil filters are to be included in the system.

3.8.8 It must be possible to isolate the analyser from the transformer and adequately bleed the analyser without the air evacuation route being through the transformer in any way. Proof of this using oil circuit diagrams must be submitted at tender stage for evaluation.

3.8.9 The system is to be capable of giving accurate and reliable results for all oil types and conditions, i.e. both new and aged in-service oils.

3.8.10 During the commissioning stage all oil lines and connections are to be guaranteed oil tight and leak free. These must be leak tested prior to connecting.

3.10 Application

3.9.1 The system may be installed on any oil-filled power transformer or reactor of any size or rating in Eskom/NTCSA at a power station, transmission sub-station or distribution station. The one pre-requisite is that the transformer has two suitable oil access valves installed.

3.9.2 All oil piping to and from the system shall be suitably sized, of stainless-steel material and have a minimum of joints along their lengths and be mechanically protected over their full length.

3.11 Environmental, Electrical and Mechanical Requirements

The device shall be substation hardened or ruggedized to be able to withstand the following, without the performance being out of limits, reliability being compromised, or the life cycle being shortened.

3.11.1 Site Condition

- Outdoor installation
- Altitude above sea level – 1800m
- Ambient temperatures
- Maximum + 55°C
- Monthly average +28°C
- Yearly average + 25°C

CONTROLLED DISCLOSURE

- Minimum - 10°C
- Average humidity of 95%.
- Solar radiation 2500Wh/m²
- Atmospheric UV radiation = High
- Seismic conditions at a minimum of 0.3g.
- Pollution level: Very Heavy (C5-M)
- Dry Heat - IEC 60068-2-2 Standard - 16 hours tolerance at +55 °C /+ 70 °C (control room / outdoor application)
- The device shall provide error-free operation when exposed to EMI stress and electrical surges, as per Class 2 requirements of IEEE 1613.

3.11.2 Electrical

The device shall:

- Operate within a Class IV (Severe) electrical interference environment [refer to TST41-1062, Table 3].
- Not be affected by other device frequencies.
- Not generate any interference, which could hinder its own performance or the performance of the other equipment in its vicinity.

3.11.3 Power Supply

- The standard power supply voltage shall be 240 Vac.
- The alternative voltage supply options, as in the AB schedule in Annexures A, shall be: 48-, 110- and 220-volts D.C.
- The voltage tolerances shall be as per TST41-1062, Table 2b
- Dual, redundant power supplies shall be provided with separate inputs per power supply to be able to draw from separate power sources, as an option.
- Power Cabling - Only UV stable, heat- and oil-resistant PVC SWA (Steel Wire Armouring) cable shall be used. Only corrosion resistant cable glands for armoured cables shall be used. Plastic compression type cable glands shall not be used on armoured cables. Heat, oil and UV resistant cable shrouds shall be fitted to all cable glands.
- All cable terminations shall be provided with cable numbers fitted to the cables on both ends. Only permanently engraved, non-corrodible, UV, oil- and heat-resistant material shall be used for cable numbering. These labels shall be permanently fixed to the cable ends just before the glands on the outside of the terminal box.
- The expected power consumption of the entire system is to be declared, see the Schedule AB.

3.11.4 Mechanical Shock and Vibration

Mechanical shock and vibration shall not affect the functioning of the device or the life cycle of at least 20 years.

- IEEE 1613-2009, IEEE Standard for environmental and testing requirements for communications networking devices installed in electric power substations.

CONTROLLED DISCLOSURE

3.12 Safety Compliance

The system shall comply with all the necessary Safety and Environmental Requirements of Eskom. An up-to-date safety file must be supplied to the Eskom/NTCSA site responsible person before any work can commence.

3.13 Technical Specifications

These Technical Specifications make provision for the Vendor to supply a multi-gas (8 gas) with moisture monitoring system as required by the Tender Document (Refer also to the Schedules A & B in Annexure A for 8 fault gases).

The Vendor supplies systems which comply with the above and following minimum requirements. If any of the applicable specifications or requirements cannot be met, the Vendor must submit a list of these deviations at the tender stage.

The AB schedule in Annexures A lists the particulars of the system with supply details and refers to the body of the specification for the detailed specification.

3.12.1 The gas and moisture capabilities of the analyser will be as per Table 2.

3.12.2 The gas analyser system shall be based on either the head space or carrier gas principles.

Table 2: The minimum specific requirements of fault gas and moisture detection

	Range: (ppm)	Accuracy:		Repeatability: (%)
		(%)	or (ppm)	
Hydrogen	5 ~ 3000	5	5	5
Methane	5 ~ 3000	5	5	5
Ethane	5 ~ 3000	5	5	5
Ethylene	5 ~ 3000	5	5	5
Acetylene	1 ~ 3000	5	2	5
Carbon monoxide	20 ~ 30000	10	20	5
Carbon dioxide	20 ~ 30000	10	20	5
Oxygen	50 ~ 10000	10	20	5
TDCG		10	20	5
Water in Oil	2 ppm 2~100%RS	5	2	5

4. Scope of Supply

The scope of supply by the Vendor shall include:

4.1 Supply of a system, as described in the above sections and specifics tabled in the AB schedules in Annexures A, for the local and remote intelligent fault gas and moisture monitoring of oil filled power transformers. This includes the supply of the analyser unit, including mounting stand, interfaces, communication, fibre optic cabling, patch panels, software, and licences.

CONTROLLED DISCLOSURE

4.2 Installation, commissioning and testing of the system on Eskom/NTCSA remote sites and installation, setup/configuration and testing of data interfaces (alongside Eskom/NTCSA primary and secondary plant personnel) with the relevant data historians/servers and SCADA systems as well as installation and setup of the servicing and end user software/configuration software (at central monitoring facilities(s) and/or remote sites) as required.

4.3 Installation and termination of all power cabling, fibre optic communication cabling, patch panels (on the transformer side and on the control room side), SCADA relay alarm cables (final connections to Eskom/NTCSA protection panels to be done by Eskom), as well as the wiring to and connection of the other sensors as per AB schedule in annexure A namely the Load CT, the Fibre Optic hot spot sensors, and the oil temperature probes. For external devices interacting via Ethernet with the analyser, the Vendor will facilitate any required networking related setups. In the AB schedule it is specified if installation of a certain part of the system is standard or shall be specifically ordered as an option.

4.4 Calibration and verification of the system at installation. This will include the taking of lab sample used as verification of the analysers reading to the Eskom/NTCSA oil laboratory for cross analysis against the values from the analysers after commissioning on site.

4.5 Full documentation describing the system, enabling operating, visualisation of the data and maintenance requirements, drawings, including manuals and compact discs with all procedures for installation, commissioning, and verification. Copies of most recent Calibration Certificates. All must be approved by Eskom. Full documentation describing the system, enabling operating, visualisation of the data and maintenance requirements, drawings, including manuals and compact discs with all procedures for installation, commissioning, and verification. Copies of most recent Calibration Certificates. All must be approved by Eskom.

4.6 Quality control documents also need to be submitted before each installation for review and acceptance by Eskom/NTCSA (Inspection and Test Plan with witness, hold and review points).

4.7 System maintenance including upgrades over the specified life span of the equipment.

4.8 Training of Eskom/NTCSA staff to operate the system, bleed the system after transformer maintenance, and configure the system.

4.9 Post installation technical support for all firmware, software and hardware related issues, spare parts, maintenance plan, intervals and strategy, and system upgrades.

5. General

Any consumable items or maintenance requirements, considering the Eskom/NTCSA drive to reduce maintenance costs, must be identified, listed, and presented at the tender stage, together with a list of all costs anticipated for the system to be fully functional over a 10-year period. This will be used in the adjudication of tenders.

- The system shall have a high operating life expectancy. Typically, more than 10 years at permanent hourly sampling rate.
- The system hardware must have a high degree of environmental protection of IP56 or better.
- A capability of self-calibration of the accuracy of results must be available.
- There shall be no effect to the long-term health of the transformer e.g. no introduction of air or any substance into the transformer oil.
- There shall be an ability to easily isolate the system from the transformer using the dedicated valves (see section 3.8.8)

CONTROLLED DISCLOSURE

- Design Review; after tender stage there shall be a design review stage where Eskom/NTCSA and the supplier will go through the details of the system for Eskom/NTCSA to be able to influence the design as appropriate.
- As per the tender documentation, there may be pilot tests (trial units) and/or a factory assessment for Eskom/NTCSA to assess the level of expertise the supplier has for the product. Eskom/NTCSA reserves the right to request this in its tenders.
- The analyser must have the facility to have samples started and stopped (safely) both locally (physically interacting with device) and remotely.

6. Implementation

The following clauses pertain to the installation and commissioning of the systems (analysers) on site and are brought to the attention of the Vendor prior to the Tender Application.

6.1 Specific Tasks and Responsibilities of the Contractor

- The Vendor will assess the site and ensure that the supplied analysers will function properly as required for the required duration and that they will not interfere with any existing plant. There will be no incompatibilities between the new equipment and the existing plant unless those accepted by the Eskom/NTCSA Project Manager in writing.
- The Vendor installs and erects all new equipment and cabling without aid from Eskom, unless otherwise agreed. During commissioning, as in the case of connection of sensors and power supplies, Eskom/NTCSA Secondary Plant and grid personnel will need to participate and must be arranged up front before work commences with the project manager. The Vendor will prepare any wiring to be connected to Eskom/NTCSA marshalling/protection panels but will not physically connect to any Eskom/NTCSA panels without direct supervision of Secondary plant personnel and using an official drawing.
- As discussed in section 3.7, the fibre optic communication infrastructure is included in the scope of the Vendor, as an order option (see Schedule AB). The Vendor must submit with the tender costs for cabling in a per/metre per analyser format. This is because cable lengths will vary from site to site.
- The vendor supplies and installs and configures all software as required by Eskom. The vendor is also responsible to facilitate the correct interfacing and configuration of the gas analyser system with Eskom/NTCSA servers/historians/SCADA systems as required. All networking configurations and cable interfaces with Eskom/NTCSA panels/systems must be done under the direct supervision of Eskom/NTCSA Secondary plant and grid personnel.
- All labour whether permanent, non-permanent, part-time or sub-contracted, is the Vendors responsibility in terms of supervision, control and safety.
- The Vendor will work according to Eskom's approval-to-work-system. No work will commence by the Vendor unless the Eskom/NTCSA Representative has given permission to do so. Permission to work will be applicable per each analyser installation.
- In cases where existing analysers are to be replaced, the Vendor will remove all the parts and material that is to be replaced or refurbished, from the existing installations. Any remnant equipment will be returned to Eskom.
- After installation and commissioning, the Vendor will demonstrate that all the installations are in a fully functional state and ready for commercial operation. This will be done by means of agreed tests and quality checks that are to be presented to the Eskom/NTCSA Representative for acceptance.

CONTROLLED DISCLOSURE

- All drawings are to be finalised and approved by the relevant engineering bodies to be submitted to the Eskom/NTCSA Project Manager to facilitate this approval.
- The Vendor supplies all tools, materials and any other resources required to complete the works.
- No modifications are to be affected on any part of the existing installation, which is to remain, or any other part of the plant, unless agreed in writing by the Eskom/NTCSA Representative.
- No work will commence unless the required quality assurance documentation has been accepted by the Eskom/NTCSA Representative.

6.2 Quality Control

The Vendor provides all the controls, checks and supervision to ensure quality of all aspects of the works. This includes any check sheets and paper work for acceptance of new equipment and material, control of the work, workmanship, tests and commissioning.

The Vendor compiles Process Quality Plans (PQPs) to cover the following processes:

- Assessment phase
- Material acceptance
- Removal of existing analysers (If applicable)
- Installation
- Testing and commissioning
- Hand over

The Eskom/NTCSA Representative reserves the right to conduct surveillance and periodic inspections, including testing, as work progresses. The Vendor submits his PQP's to the Eskom/NTCSA Project Manager for acceptance before any work commences. Eskom/NTCSA shall evaluate the Vendors manufacturing and test facilities, as well as the local agents' facilities for maintenance, repair and spares handling.

All the requirements of QM58 also apply.

The concept design and, where possible, equipment shall be standardized across all installations of the system.

7. Service Life and Life Cycle Costing

- The service life of the system is to be at least 10 years and ideally be maintenance free. It shall be indicated how the vendor intends to achieve this service life from their product. Further, the vendor must indicate at time of tender the expected maintenance, upgrade, and any replenishment costs of the system for the full 10-year period. These costs include, but are not exclusive to:
 - Replacement parts and labour associated with normal wear and tear of the system.
 - Replenishment of any consumables (e.g. carrier gas, gas separation columns, sensors, calibration gas etc.) including any associated labour charges.
 - Call-out charges for items not covered in the standard warranty of the system.
- All hardware and software (for the OEMs suite of software available for use with the device offered) upgrades shall be free of charge for the first 5 years of service of the systems.

CONTROLLED DISCLOSURE

8. Supportability and Maintainability

Full maintenance and support for the system shall be provided by a company based in South Africa. The company shall provide a locally available spares holding sufficient to maintain at least 5% of the fleet installed in Eskom/NTCSA at any time. Support shall be provided on a reasonable turn-around time, taking into consideration mainly the risk in the operations, the distance between site and service provider's base location, and the access requirements to site.

8.1 Reliability, Availability and Maintainability (RAM Programme)

While under guarantee and/or for units with maintenance contract the vendor/supplier must provide Eskom/NTCSA (the Contracts Manager, Project Manager, and Engineering department) a RAM report at 2 months, 6 months, 2 years, and 3 years for every unit that is installed from the date of installation.

- This report must clearly include the statistics of:
- The data availability (including the communication and software components of the system).
- The gas sampling and analysis functions of the system (this must include a list of all errors the system encountered as well as number of samples out of the total which had to be aborted or were erroneous).
- The number of times the supplier/vendor had to intervene under warranty and the cost to them for those repairs.
- The training certificates for the persons in Eskom/NTCSA trained for those specific units.

Furthermore, during operation of the analyser, Eskom/NTCSA will, when a gas alarm is encountered (at its discretion) also take an oil sample(s) for laboratory analysis, and if the analysers results are not concurrent with the labs results, a non-conformance report (under RAM) will be issued to the supplier. In these cases, the supplier will need to explain why this is the case and the occurrence will be added to the RAM programme statistics for erroneous/misleading samples.

Eskom/NTCSA will use the RAM Programme for future tender evaluations for returning suppliers. Failure to submit any of the above-mentioned RAM reports will result in commercial penalties.

8.2 Maintenance Philosophy

The gas analyser OEM must provide a detailed maintenance philosophy (what and when) for the instrument's lifetime. It is required that the details of the maintenance plan and related cost be part of the bid submissions. Eskom/NTCSA will enter into agreements of maintenance plans at its own discretion.

9. Training

A formal training program for Eskom/NTCSA staff shall be provided by the vendor. This shall make provision for the training of groups of the relevant Eskom/NTCSA station staff. A 'standard' training should be performed for around 6 individuals per installation. The training shall cover the following aspects:

- Principles of operation of the system
- System installation and commissioning
- System setup and communication

CONTROLLED DISCLOSURE

- How to operate/test the system under all operating conditions these should include but are not limited to:
 - When an analyser is connected to live transformer and in operation
 - When an analyser needs to be disconnected from its transformer due to analyser malfunction
 - When an analyser needs to be disconnected from its transformer due to transformer maintenance (see points below)
 - When an analysers alarm (including the hardwired relay alarms, SMS alarms and SCADA messages) need to be tested
 - When an urgent sample needs to be started (both manually and remotely)
 - When service logs need to be downloaded (both manually and remotely) and sent to the OEM for analysis
- System parameter configuration (both local and remote)
- Network Switch/Modem/Firmware/Communication testing and setup
- System software functions
- Troubleshooting
- Disconnection and reconnection of the system (including but not limited to the procedures for opening and closing of oil pipe valves, bleeding procedure etc.) before and after maintenance of the power transformer or reactor in question.

There shall also be 6 monthly centralised (Johannesburg and surrounds) training during the contract validity period, with no additional cost to Eskom, where all the above and additional advanced topics must be lectured upon. These interventions would also be the expected forum for the introduction and training thereof of software/firmware updates and system enhancements.

Certification of Eskom/NTCSA staff for both training types must be provided with a hard copy and soft copy certificate. At tender stage, the training material, example accreditation, schedules etc. should be submitted, this will be used in the tender adjudication.

10. Documentation

The system including all hardware and software, shall be documented in such a way that Eskom/NTCSA may be able to allow working on the system by any suitably qualified person. This documentation shall also include all installation, operating settings, and interfacing instructions in a clear set of information. All manuals shall be made available electronically (to the Grid/Substation Senior Advisor, the Contracts Manager, Project Manager, and Engineering department) in addition to at least five hardcopies being supplied once off (at contract award stage to the contracts manager) and 2 sets of hardcopy manuals to be provided to the site (given to the site supervisor) in question per installation. Any changes in the versions of the hardware or software shall reflect in the documentation.

The bound folders/files shall contain as a minimum:

- Description of the system
- Drawings to give precise indication of oil flow, isolations and all major components required for maintenance and operating purposes

CONTROLLED DISCLOSURE

- Drawings to show connection to the transformer and any sensors, power supply or auxiliaries that are installed
- Generic Drawings of all the cabinets, enclosures, stands, antennas, patch and communication panels, relay interfaces and cabling interfaces
- Maintenance intervals, spares, descriptions, and operating requirements and instructions
- Software user instructions
- Calibration certificates
- All data sheets of constituent devices (such as media converters, modems, fibre optic devices)

11. Acceptance

This document has been seen and accepted by:

Name	Designation
Bheki Ntshangase	Senior Manager – SCOT Plant Study Committee Chair
Sidwell Mtetwa	Corporate Specialist – SCOT Transformer CG Chair
Khayakazi Dioka	Corporate Specialist – Transformers & Reactors
Mantsie Hlakudi	Chief Engineer – Transformers & Reactors
Mashilo Moabelo	Chief Engineer – Dx Transformers
Lionel Jordaan	Snr Consultant – Gx Transformers
Nad Moodley	Middle Manager – Gx Peaking Transformers
Matome Matlhadisa	Corporate Specialist – Grids
Bongani Qwabe	Chief Technologist – Secondary Plant

12. Revisions

Date	Rev.	Compiler	Remarks
June 2013	1	C. Wolmarans	First Issue
February 2025	2	S. Miya	<ul style="list-style-type: none">• New document template and inclusion of NTCSA• Added Portable DGA• Removed 4 multi-gases requirements

13. Development Team

The following people were involved in the development of this document:

- Sanele Miya
- Sidwell Mtetwa

14. Acknowledgements

Not applicable.

CONTROLLED DISCLOSURE

**TECHNICAL STANDARD FOR PERMANENTLY FIXED AND PORTABLE
GAS ANALYSER FOR APPLICATION IN POWER TRANSFORMERS AND
REACTORS**

Unique Identifier: 240-64917195

Revision: 2

Page: 25 of 46

Annex A – Permanent Online Dissolve Gas Analyser AB Schedule

SCHEDULE AB: Eskom/NTCSA Specific Requirements

Item	Related Clause	Description	Supply Requirement	Schedule [A]	Schedule [B]
1	Gas Detection		Standard	Comply with table 2 for all gases and moisture.	
1.1	Hydrogen	3.12, Table 2	Standard	Range: 5 – 3000 ppm Accuracy: 5 ppm	
1.2	Methane	3.12, Table 2	Standard	Range: 5 – 3000 ppm Accuracy: 5 ppm	
1.3	Ethane	3.12, Table 2	Standard	Range: 5 – 3000 ppm Accuracy: 5 ppm	
1.4	Ethylene	3.12, Table 2	Standard	Range: 5 -3000 ppm Accuracy: 5 ppm	
1.5	Acetylene	3.12, Table 2	Standard	Range: 1 – 3000 ppm Accuracy: 2 ppm	
1.6	Carbon monoxide	3.12, Table 2	Standard	Range: 20 - 30000 ppm Accuracy : 20 ppm	
1.7	Carbon dioxide	3.12, Table 2	Standard	Range: 20 – 30000 ppm Accuracy: 20 ppm	
1.8	Oxygen	3.12, Table 2	Standard	Range: 50 – 10000 ppm Accuracy : 20 ppm	

CONTROLLED DISCLOSURE

**TECHNICAL STANDARD FOR PERMANENTLY FIXED AND PORTABLE
GAS ANALYSER FOR APPLICATION IN POWER TRANSFORMERS AND
REACTORS**

Unique Identifier: **240-64917195**

Revision: **2**

Page: **26 of 46**

1.9	TDCG	3.12, Table 2		Standard	Accuracy: 20 ppm	
2	Moisture detection Water in oil	3.12, Table 2		Standard	Range 2 – 100% Relative Saturation or 2 ppm Accuracy: 2 ppm	
3	Sampling					
3.1	Measurement frequency (min)			Standard	1 Hours	
3.2	Measurement frequency (max)			Standard	24 Hours	
3.3	On Board data storage	3.1	At highest sample rate , capacity shall be sufficient for min. 1 year	Standard	Minimum 1 year, at highest sample rate	
3.4	Auto and self- Calibration or verification	3.1.1 4.4	System shall flag when results differ from requirements in table 2 for all gases and water.	Standard	Required, Please provide documents reflecting evidence	
4	Alarm Outputs	3.2				
4.1	LED Indicators	3.2.1	4 colours, Normal green, Service – Blue, Gassing Caution - Orange, Gassing Alarm - Red (see section 4.2)	Standard	Required, bright LED must be clearly visible in daylight	

CONTROLLED DISCLOSURE

When downloaded from the document management system, this document is uncontrolled and the responsibility rests with the user to ensure it is in line with the authorized version on the system. No part of this document may be reproduced in any manner or form by third parties without the written consent of National Transmission Company South Africa SOC Ltd
Reg No 2021/539129/30

**TECHNICAL STANDARD FOR PERMANENTLY FIXED AND PORTABLE
GAS ANALYSER FOR APPLICATION IN POWER TRANSFORMERS AND
REACTORS**

Unique Identifier: **240-64917195**

Revision: **2**

Page: **27 of 46**

4.2	SCADA alarms via communication protocols	3.2.2 3.2.3 3.2.4	Alarming to Eskom/NTCSA SCADA server via IEC 61850/IEC 101/DNP 3.0 for a normal or abnormal state, service, gassing caution and alarm. Concentration/ROC value causing alarm shall also be part of the notification.	Standard	Required, must meet requirements of clauses 4.2.2, 4.2.3, 4.2.4 and 4.4	
4.3	SCADA alarms with relays	3.2.3 3.2.7	Alarming with 4 relays for ab/normal state, service, gassing caution and gassing alarm.	Standard	4 relays , one for each state/alarm	
4.4	Relay general ratings	3.2.7 ESP 32-333	Dry contact relays, Switching voltage	Standard	110/220 Vdc without modification. Dry contact, NO/NC ESP 32-333	
4.5		Table 1	Make and carry current Carry continuously Break (Inductive L/R = 40ms)	Standard	1 A @ 250 Vdc 1A 10 W @ 250 Vdc And ESP 32-333	
4.6	Terminal Blocks	ESP 32-333, 3.7	All terminal blocks must be spring loaded	Standard	Spring loaded, must conform to ESP 32-333	

CONTROLLED DISCLOSURE

When downloaded from the document management system, this document is uncontrolled and the responsibility rests with the user to ensure it is in line with the authorized version on the system. No part of this document may be reproduced in any manner or form by third parties without the written consent of National Transmission Company South Africa SOC Ltd
Reg No 2021/539129/30

**TECHNICAL STANDARD FOR PERMANENTLY FIXED AND PORTABLE
GAS ANALYSER FOR APPLICATION IN POWER TRANSFORMERS AND
REACTORS**

Unique Identifier: **240-64917195**

Revision: **2**

Page: **28 of 46**

4.7	Relay cabling	3.2.7	PVC SWA cable, between analyser relays and transformer MIB or control room as required	Cables to MIB must be standard. Cables between MIB and control room, supply and installation thereof, must appear as an option with a per metre price.	PVC SWA, Must meet requirements of clause 3.2.7.4	
4.8	Direct SMS notification	3.2.2 3.2.4	SMS notifications for the alarms from GSM modem of for abnormal state, service, gassing caution and alarm. Concentration/ROC value causing alarm shall also be part of the notification.	Standard	SMS notifications to 5 points	
4.9	Local Indication and control	3.2.5	LCD screen on device for data and alarm log viewing and graphing. Must be able to start samples, stop samples and interrogate device (system status and gas values) manually	Standard	Required, LCD Screen, Requirements of 4.2.1.5	
4.10	Gas Alarming calculations and settings	3.2.6	Caution and Alarm thresholds for gassing and parameters shall be concentration and/or Rate Of Change based (ROC) over a set period for each gas and moisture.	Standard	Required, Concentration and ROC based Alarms shall be set for each gas & moisture over full range.	

CONTROLLED DISCLOSURE

When downloaded from the document management system, this document is uncontrolled and the responsibility rests with the user to ensure it is in line with the authorized version on the system. No part of this document may be reproduced in any manner or form by third parties without the written consent of National Transmission Company South Africa SOC Ltd
Reg No 2021/539129/30

**TECHNICAL STANDARD FOR PERMANENTLY FIXED AND PORTABLE
GAS ANALYSER FOR APPLICATION IN POWER TRANSFORMERS AND
REACTORS**

Unique Identifier: 240-64917195

Revision: 2

Page: 29 of 46

			Ranges and accuracies for gases and moisture as per table 2 shall be in line with the alarm setting resolutions and ranges.			
5	Communication and protocols					
5.1	General	Eskom/N TCSA standard 2406403 8621, 3.3, 3.4	Must confirm to the Eskom/NTCSA standard for data retrieval and remote access	Standard	Meet all requirements of 240-64038621	
5.2	IEC 61850 IEC 101	Eskom/N TCSA standard 2406403 8621	For use in substation environment	standard	IEC 61850 AND IEC 101, Meet requirements of 240-64038621	
5.3	IEC 61850-8-1 MMS Server	Eskom/N TCSA standard 2406403 8621	For use in substation environment, must conform to requirements	standard	Meet requirements of 240-64038621	
5.4	DNP 3	Eskom/N TCSA standard 2406403 8621	For use in non-substation environment	standard	DNP 3.0, Meet requirements of 240-64038621	

CONTROLLED DISCLOSURE

When downloaded from the document management system, this document is uncontrolled and the responsibility rests with the user to ensure it is in line with the authorized version on the system. No part of this document may be reproduced in any manner or form by third parties without the written consent of National Transmission Company South Africa SOC Ltd
Reg No 2021/539129/30

**TECHNICAL STANDARD FOR PERMANENTLY FIXED AND PORTABLE
GAS ANALYSER FOR APPLICATION IN POWER TRANSFORMERS AND
REACTORS**

Unique Identifier: 240-64917195

Revision: 2

Page: 30 of 46

5.5	File transfer	Eskom/N TCSA standard 2406403 8621	Decoupled from OEM tool Support HTTP and FTP Push files IEC 61850-8-1 MMS File Services	Standard	Decoupled, HTTP and FTP, Push support IEC 61850-8-1 MMS	
5.6	Remote access support	Eskom/N TCSA standard 2406403 8621, 3.4	Remote access using configuration tools/software must support IEC 61850 and HTTP	standard	Yes, Using IEC 61850 and HTTP	
6	Configuration Software	3.4				
6.1	Configuration and diagnostics	3.4	Using protocols and communication as defined above	Standard	Required, configurations via web interface from web server running on device	
6.4	User License	3.4	All software licenses for related software for device.	Standard	Eskom/NTCSA wide license with no limit on	
6.5	Operating system	3.4	Software compatible with Windows server 2003, 2008 and 2012 and Windows 7 and Windows XP. Web interfaces must be compatible with IE 8 and above.	Standard	Win XP, Win 7, Win Server 2003, 2008 , 2012 , IE8 and above (Web interfaces) Provide detailed list of OS support.	

CONTROLLED DISCLOSURE

When downloaded from the document management system, this document is uncontrolled and the responsibility rests with the user to ensure it is in line with the authorized version on the system. No part of this document may be reproduced in any manner or form by third parties without the written consent of National Transmission Company South Africa SOC Ltd
Reg No 2021/539129/30

**TECHNICAL STANDARD FOR PERMANENTLY FIXED AND PORTABLE
GAS ANALYSER FOR APPLICATION IN POWER TRANSFORMERS AND
REACTORS**

Unique Identifier: **240-64917195**

Revision: **2**

Page: **31 of 46**

7	External Sensors - inputs	3.6					
7.1	Load CT	3.6.1	Analogue clip on load CT, Nominal 0 - 5A	Optional, including installation	Required, 0-5 A range. Provide datasheet.		
7.2	Transformer winding temperature - Fibre Optic Hot Spot sensors	3.6.2	Hot spot temperature probes either Luma-sense (Luxtron) or Neoptix signal conditioner (2 channel min.) , wiring and connection to transformers probes	Optional, including signal conditioner, extension cables to transformer probe connections and installation thereof.	2 channel minimum Neoptix or Lumasense (Luxtron)		
7.3	Oil temp probe input	3.6.3	Interface with an oil temperature signal on 420mA or RTD	Interface Standard, wiring between probe and analyser shall be optional	Required via 4-20 mA or RTD		
7.4	Eskom/NTCSA Partial Discharge unit interface input	3.6.4	Eskom/NTCSA PD system interface via IP network ports either via RJ45 100BaseTX or LC MM 100BaseFX	Standard	Required, will use the interfaces as below 9.1.		
7.5	4-20 mA inputs	3.6.6	4 X Spare inputs for other devices	Standard	Required, 4 x Spare 4-20mA inputs		
7.6	Serial RS485 inputs	3.6.6	2 X Spare inputs for other devices	Standard	Required 2 x RS485 inputs		
8	Enclosure and electrical terminations	3.7					

CONTROLLED DISCLOSURE

When downloaded from the document management system, this document is uncontrolled and the responsibility rests with the user to ensure it is in line with the authorized version on the system. No part of this document may be reproduced in any manner or form by third parties without the written consent of National Transmission Company South Africa SOC Ltd
Reg No 2021/539129/30

**TECHNICAL STANDARD FOR PERMANENTLY FIXED AND PORTABLE
GAS ANALYSER FOR APPLICATION IN POWER TRANSFORMERS AND
REACTORS**

Unique Identifier: **240-64917195**

Revision: **2**

Page: **32 of 46**

8.1	Main unit enclosure	3.7.1	Weather proof IP 56 stainless steel grade 316	Standard	Requirements of 3.7.1, enclosure rated IP 56 and stainless steel 316	
8.2	Shock mount	3.7.1	Shock mounting as optional	Optional	Shock mounting, provide proposed drawings	
8.3	Stands , pipes, fasteners and valves	3.7.1 3.7.3	Stainless Steel Grade 316 and Stand firmly mounted and stand and system (bonded) earthed to earth mat	Required	Stainless steel 316L, requirements of 4.7.1.1 Stand and system earthed to earth mat Device Viewing height on stand 1200 - 1500mm	
8.4	Sun / heat shields	4.7.1.1.1	Sun or heat shields to prevent UV damage	Optional	Required	
8.5	Cable entry	4.7.1.1.2	Water tight and weather resistant , entry from vertically below	Standard	Requirements of	
8.6	Terminal blocks	3.7.5 3.7.7	Rail mounted terminals, spring loaded terminals and terminal screws with two hooked blades. All requirements of EST 32-333 for all terminals.	Standard	Requirements of 3.7.5 and 3.7.7 And EST 32-333	
8.7	Terminal and cable labelling	3.7.8	All terminals and cables to be clearly labelled and numbering corresponding on drawings to be submitted	Standard	Requirements of 3.7.8, all drawings to be submitted	

CONTROLLED DISCLOSURE

When downloaded from the document management system, this document is uncontrolled and the responsibility rests with the user to ensure it is in line with the authorized version on the system. No part of this document may be reproduced in any manner or form by third parties without the written consent of National Transmission Company South Africa SOC Ltd
Reg No 2021/539129/30

**TECHNICAL STANDARD FOR PERMANENTLY FIXED AND PORTABLE
GAS ANALYSER FOR APPLICATION IN POWER TRANSFORMERS AND
REACTORS**

Unique Identifier: 240-64917195

Revision: 2

Page: 33 of 46

9	Communication hardware	3.8		Standard		
9.1	Primary communication – Ethernet network ports	3.8.1 3.8.3	Ethernet interface for primary communication and for connecting other network devices if required (see 4.6.1.4). 100 Base TX 2 x RJ 45 and 100 Base FX Multimode 2 x LC connectors (50/125 um)		2 x 100 Base TX RJ45 and 2 x LC 100 Base FX MM On device. Requirements of 3.8.1 and IEC 61850 and IEEE 1613	
9.2	Communication Cabinet and patch panel for Fibre optic communication (Transformer/Analyser Side)	3.7.4 3.8.2	Cabinet to house patch panel for fibre optic cable connections to be terminated, adjacent to analyser(s). To contain the spliced incoming cables from control room to labelled LC connectors for connection to cable/leads going to analyser(s). Details to be clarified at tender stage and thereafter detailed for each order.	As an option, to include installation. Cost per cabinet and patch panels shall be provided itemised.	Requirements of 3.7.4, IP56 enclosure, to be mounted on stainless steel 316L stand, contain patch panel to have 6 LC connections. Proposed drawings to be provided.	
9.3	Fibre optic cabling and cables	3.8.2 3.8.3	Includes supply and installation (including splicing and termination) of all required fibre optic cables as per section 4.8. Cables between control room and analyser	Optional, including supply and installation. Cost of Cable and installation of cable	Cabling to Comply with 240-46264031 and 240-46263618 Cables between control room and analyser communication cabinet patch panel shall be 12 core.	

CONTROLLED DISCLOSURE

**TECHNICAL STANDARD FOR PERMANENTLY FIXED AND PORTABLE
GAS ANALYSER FOR APPLICATION IN POWER TRANSFORMERS AND
REACTORS**

Unique Identifier: 240-64917195

Revision: 2

Page: 34 of 46

			communication cabinet and leads/cable (as required) between cabinet and analyser to be provided and installed. All cabling to be confirmed at tender stage and at orders thereafter.	must be quoted per metre.	Cables between transformers patch panel and analyser units shall be 4 core. Multimode 50/125um. Heavy Duty Duct Cable All Fibre in HDPE ducts. LC terminations. Provide datasheets.	
9.4	Fibre optic Patch panel in control room	3.8.2	Cables must be terminated with clearly labelled LC connectors in a patch panel in the control room. Details to be clarified at tender stage and thereafter detailed for each order	Optional, including supply installation	Cables terminated in a Patch panel with 12 x LC connectors in control room.	
9.5	Local USB connection	3.8.4	Local connection shall be possible via USB and shall have password protection	Standard	Required	
	Alternative communication					
9.10	PSTN Modem	3.8.5	POTS, Backup/Legacy communication via modem	Option	Required, PSTN	
9.11	GSM, GPRS, EDGE, UMTS and CSD Modem	3.8.5	Backup /Legacy communication via GSM modem. GPRS/EDGE/UMTS support fully compatible	Standard	Required, SMS capability also required High gain antenna must be included. Provide datasheet	

CONTROLLED DISCLOSURE

**TECHNICAL STANDARD FOR PERMANENTLY FIXED AND PORTABLE
GAS ANALYSER FOR APPLICATION IN POWER TRANSFORMERS AND
REACTORS**

Unique Identifier: **240-64917195**

Revision: **2**

Page: **35 of 46**

			with Private APN architecture required			
10	External cabling/wiring	3.8.6	All external wiring and cabling to be in steel conduit. Fibres in HDPE duct.	Standard	Required, must conform to 4.8.1.6	
11	Oil Interface	3.9				
11.1	Main inlet and outlet Valves	3.9.1	If dedicated valves for monitor not on transformer, vendor to provide. System must have continuous oil flow. All valves to be Stainless Steel Grade 316.	Standard	Required, Stainless steel 316 L, requirements of 3.9.1 and 3.7.1	
11.2	Oil lines/pipes	3.9.1	All pipes and lines to be provided stainless steel	Standard	Stainless steel 316 L Oil lines/pipes	
11.3	Pipe fittings and flanges	3.9.2	Vendor must provide adequate pipe fittings and flanges so pipes have adequate support both horizontally and vertically.	Standard	Pipe fittings and flanges as per 3.9.2 and 3.7.1 Stainless steel 316	
11.4	Oil take off and	3.9.3	Oil take off and return valves, standard oil sampling points on transformer not to be used or dispensed with.	Standard	50 mm or 25 mm diameter double flange valves, stainless steel 316, requirements of 3.7.1 and 3.9.3	

CONTROLLED DISCLOSURE

When downloaded from the document management system, this document is uncontrolled and the responsibility rests with the user to ensure it is in line with the authorized version on the system. No part of this document may be reproduced in any manner or form by third parties without the written consent of National Transmission Company South Africa SOC Ltd
Reg No 2021/539129/30

**TECHNICAL STANDARD FOR PERMANENTLY FIXED AND PORTABLE
GAS ANALYSER FOR APPLICATION IN POWER TRANSFORMERS AND
REACTORS**

Unique Identifier: 240-64917195

Revision: 2

Page: 36 of 46

11.5	Oil sample valve (inlet line to system)	3.9.4	Sampling point valve close to analyser on incoming oil line to analyser to be provided	Standard	Required, requirements of 3.9.4	
11.6	Oil loop	3.9.5	Oil intake and outlet points on transformer	Standard	Requirements of 3.9.5	
11.7	Removal of air-in-oil return	3.9.5	Means for eliminating any air-in-oil return to transformer	Standard	Required, provide evidence of system/mechanism	
11.8	No oil contamination	3.9.6	Return oil to transformer to be free from any contaminants caused by analyser	Standard	Required, provide evidence	
11.9	In line oil filters	3.9.6	In line oil filters to be part of system	Standard	Required, provide details	
11.10	Independent valves on oil lines	3.9.7	System requires integral independent valves on inlet and outlet oil lines.	Standard	Required, requirements of 3.7.1. Stainless steel 316.	
11.11	Oil types and conditions	3.9.8	System must be capable of giving accurate and reliable results for all oil types and conditions i.e. new and in service aged oils.	Standard	All types of oil and oil condition please provide detailed oil compatibility information.	
11.12	Commissioning of oil lines and interfaces	3.9.9	During commissioning all lines and interfaces to be guaranteed oil tight and leak free	Standard	Required, leak tests required during commissioning, provide detail of proposed tests and procedures.	

CONTROLLED DISCLOSURE

**TECHNICAL STANDARD FOR PERMANENTLY FIXED AND PORTABLE
GAS ANALYSER FOR APPLICATION IN POWER TRANSFORMERS AND
REACTORS**

Unique Identifier: 240-64917195

Revision: 2

Page: 37 of 46

11.13	Oil pressure withstand		The device as a minimum shall withstand 3 bar oil pressure	Standard	Required, 3 Bar minimum	
11.14	Anti- Cavitation pumps		Anti-cavitation pumps required	Standard	Required, provide detail	
11.15	Oil Air Bleed facility		Oil air bleeding facility for commissioning required	Standard	Required , Oil air bleeding facility	
12	Application	3.10.1	System may be installed on any oil filled power transformer or reactor of any size or rating.	Standard	Requirements of 3.10.1, any oil filled power transformer of any size or rating with access valves present.	
12.1	Oil piping to and from system	3.10.2	Stainless steel 316 piping, suitably sized for application, has minimum joints along length and be mechanically protected over full length.	Standard	Stainless steel 316 piping. Mechanical protection over full length (steel conduit or equivalent protection)	
13	Environmental, Electrical and Mechanical	3.11				
13.1	System hardware		Environmental protection	Standard	Minimum IP 56 rating	
13.2	Operating Temperature range		Operating temperature range of system and constituent hardware	Standard	-10 to 50 °C with passive cooling	
13.3	Operating oil temperature range		Operating oil temperature range	Standard	0 to 120 °C outdoors	

CONTROLLED DISCLOSURE

When downloaded from the document management system, this document is uncontrolled and the responsibility rests with the user to ensure it is in line with the authorized version on the system. No part of this document may be reproduced in any manner or form by third parties without the written consent of National Transmission Company South Africa SOC Ltd
Reg No 2021/539129/30

**TECHNICAL STANDARD FOR PERMANENTLY FIXED AND PORTABLE
GAS ANALYSER FOR APPLICATION IN POWER TRANSFORMERS AND
REACTORS**

Unique Identifier: **240-64917195**

Revision: **2**

Page: **38 of 46**

13.4	Operating humidity range		Operating humidity range	Standard	0 to 100% outdoors	
13.5	Environmental Class		Environmental class as per IEC 60721-3-3	Standard	Class 3K7 as per IEC 60721-3-3	
13.6	Operating altitude		Operating altitude range	Standard	0 to 2500m	
13.7	EMI immunity		System and hardware to have Error-free operation under EMI and electrical surges as per class 2 of IEEE 1613	Standard	Class 2 of IEEE 1613	
13.8	Electrical Environment		Device shall operate in a class IV severe electrical interference environment, see TST 41-1062 table 3	Standard	Device must operate in class IV severe electrical environment I as per TST 41-1062 table 3	
13.9	EMI/EMC		Device shall not be affected by other device frequencies. Device shall not generate any EM interference.	Standard	Device not affected by other frequencies. Device shall not generate any EMI. Provide details of EMC.	
14	Power Supply	3.10.3				

CONTROLLED DISCLOSURE

When downloaded from the document management system, this document is uncontrolled and the responsibility rests with the user to ensure it is in line with the authorized version on the system. No part of this document may be reproduced in any manner or form by third parties without the written consent of National Transmission Company South Africa SOC Ltd
Reg No 2021/539129/30

**TECHNICAL STANDARD FOR PERMANENTLY FIXED AND PORTABLE
GAS ANALYSER FOR APPLICATION IN POWER TRANSFORMERS AND
REACTORS**

Unique Identifier: **240-64917195**

Revision: **2**

Page: **39 of 46**

14.1	Standard supply	Standard supply voltage 230 Vac with tolerances as per TST 41-1062 Table 2b.	Standard	230 Vac with tolerances as per TST 41-1062 Table 2b.	
14.2	Supply protection	Power supply shall have transient protection and thermal cut out fuses	Standard	Required, provide details and evidence of transient protection and thermal cut out fuses.	
14.3	Alternative supply(s)	Other supply voltages as required to be specified at order. Tolerances as per TST 41-1062 Table 2b.	Optional, as required, quote for each as an additional item.	48V DC 110V DC 220V DC	
14.4	Dual redundant supplies	Supply to be dual redundant with separate supplies	Optional	Dual redundant supply	
14.5	Power consumption	Expected power consumption of entire system on supply		Provide details, and detail in schedule B. Max current	
14.6	Power cabling	PVC SWA cable to be used meeting requirements of 3.11.6	Standard	Required, PVC SWA cable	
14.7	Mechanical Shock and vibration	Mechanical shock and vibration shall not affect the functioning of the device	Standard	Required, must comply with IEC TS 61000-6-5:2001 and IEEEE 16132009	

CONTROLLED DISCLOSURE

When downloaded from the document management system, this document is uncontrolled and the responsibility rests with the user to ensure it is in line with the authorized version on the system. No part of this document may be reproduced in any manner or form by third parties without the written consent of National Transmission Company South Africa SOC Ltd
Reg No 2021/539129/30

**TECHNICAL STANDARD FOR PERMANENTLY FIXED AND PORTABLE
GAS ANALYSER FOR APPLICATION IN POWER TRANSFORMERS AND
REACTORS**

Unique Identifier: 240-64917195

Revision: 2

Page: 40 of 46

15	Safety	3.12	Device and installation and contractors to meet Eskom/NTCSA safety requirements	Standard	Required, Contractor responsible for Safety file approvals by Eskom/NTCSA	
16	Scope of Supply	4				
16.1	Installation and commissioning		Installation, commissioning and testing of system including cables and hardware as tabled in the specification and this schedule, and supply requirement column as either standard or an option to appear on contract.	Standard	Required, Installation, testing, and commissioning.	
16.2	Calibration and verification at installation and commissioning		Cross checking of calibration of device and gas and moisture readings against Eskom/NTCSA lab sample.	Standard	Required, Vendor responsibility to cross check Eskom/NTCSA lab sample with device on commissioning.	
16.3	Quality documents and processes		Submission of ITP/PQP documents for Eskom/NTCSA approval.	Standard	Required, must meet requirements of QM 58.	
16.4	System maintenance and upgrades		All maintenance and upgrades over declared lifespan of equipment period of analyser to be included.	Standard but Service and maintenance costing to be itemised.	Required, Including maintenance and upgrades over lifespan.	

CONTROLLED DISCLOSURE

When downloaded from the document management system, this document is uncontrolled and the responsibility rests with the user to ensure it is in line with the authorized version on the system. No part of this document may be reproduced in any manner or form by third parties without the written consent of National Transmission Company South Africa SOC Ltd
Reg No 2021/539129/30

**TECHNICAL STANDARD FOR PERMANENTLY FIXED AND PORTABLE
GAS ANALYSER FOR APPLICATION IN POWER TRANSFORMERS AND
REACTORS**

Unique Identifier: 240-64917195

Revision: 2

Page: 41 of 46

16.5	Technical support		Technical support post installation on all hardware software and communication interfaces.	Standard	24/7 telephonic and email support.	
17	General	5				
17.1	Life expectancy		Device life at maximum sampling frequency	Required	15 years, with maintenance	
18	Implementation	6				
18.1	Site assessing, installation, cabling and wiring		Vendor will assess site, equipment compatibility checked. Installation of all hardware and cabling.	Required	Requirements of 7.1.1.1 and 7.1.1.2	
18.2	Software and system interface setup		Software installation, system configuration with Eskom/NTCSA historians and SCADA system.	Required	Vendor installs and configures all software and System interfaces as required. Requirements of 7.1.1.4	
18.3	Labor and subcontractors		All labour and subcontractors	Required	Vendor's responsibility.	
18.4	Work permits		Eskom/NTCSA approval to work system	Required	Vendors responsibility, requirements of 7.1.1.6	
18.5	Quality control		Quality documents (ITP and PQP) control, checks and supervision requirement	Required	Requirements of 7.2, and QM 58.	

CONTROLLED DISCLOSURE

When downloaded from the document management system, this document is uncontrolled and the responsibility rests with the user to ensure it is in line with the authorized version on the system. No part of this document may be reproduced in any manner or form by third parties without the written consent of National Transmission Company South Africa SOC Ltd
Reg No 2021/539129/30

**TECHNICAL STANDARD FOR PERMANENTLY FIXED AND PORTABLE
GAS ANALYSER FOR APPLICATION IN POWER TRANSFORMERS AND
REACTORS**

Unique Identifier: **240-64917195**

Revision: **2**

Page: **42 of 46**

18.6	Standardization	Standardisation of system across Eskom/NTCSA	Required	Design and equipment across Eskom/NTCSA to be standardized
19	Service life and lifecycle costing	9		
19.1	Maintenance and consumable costs	The specifications and costs of any consumables or maintenance required over 20 year period must be provided.	Costs to be provided for itemised parts/servicing, call out charges and consumables	Requirements of section 9. Provide specifications and costs of consumables and maintenance requirements
19.2	Warranty	Warranty for 5 years. All consumables, hardware, firmware, software upgrades shall be free of charge until the end of useful life of the analyser	Required	5 years, on all equipment. All Upgrades, Consumables, included for 5 years.
19.3	Local maintenance support	Maintenance and support to be provided by local company in South Africa. 5 % local spares holding required.	Required	Maintenance and support to be local. 5 % spares holding of Eskom's systems. Technical Support within one working day.
19.4	Spares turnaround		Required	Required, spares within one working day. Provide spare lead time information.

CONTROLLED DISCLOSURE

**TECHNICAL STANDARD FOR PERMANENTLY FIXED AND PORTABLE
GAS ANALYSER FOR APPLICATION IN POWER TRANSFORMERS AND
REACTORS**

Unique Identifier: **240-64917195**

Revision: **2**

Page: **43 of 46**

19.5	Training	9	Formal training to be included. Curriculum as in section 11.	Required, training to occur per installation for 6 people.	Requirements of section 11, submit training content and programs	
20	Documentation	10	All manuals, drawings, operating and maintenance procedures, datasheets to be submitted.	Required	Documentation to be submitted as per section 10. Soft copy on CD to be submitted. 5 Hardcopies of manuals and documentation to be supplied one-off. Additional, 2 Hardcopy's per installation.	

CONTROLLED DISCLOSURE

When downloaded from the document management system, this document is uncontrolled and the responsibility rests with the user to ensure it is in line with the authorized version on the system. No part of this document may be reproduced in any manner or form by third parties without the written consent of National Transmission Company South Africa SOC Ltd
Reg No 2021/539129/30

Annex B – Portable Dissolve Gas Analyser AB Schedule

Item	Schedule [A]	Schedule [B]
1 Gas Detection 3.12, Table 2	Comply with table 2 for all gases and moisture.	
1.1 Hydrogen 3.12, Table 2	Range: 5 – 3000 ppm Accuracy: 5 ppm	
1.2 Methane 3.12, Table 2	Range: 5 – 3000 ppm Accuracy: 5 ppm	
1.3 Ethane 3.12, Table 2	Range: 5 – 3000 ppm Accuracy: 5 ppm	
1.4 Ethylene 3.12, Table 2	Range: 5 -3000 ppm Accuracy: 5 ppm	
1.5 Acetylene 3.12, Table 2	Range: 1 – 3000 ppm Accuracy: 2 ppm	
1.6 Carbon monoxide 3.12, Table 2	Range: 20 - 30000 ppm Accuracy : 20 ppm	
1.7 Carbon dioxide 3.12, Table 2	Range: 20 – 30000 ppm Accuracy: 20 ppm	

CONTROLLED DISCLOSURE

**TECHNICAL STANDARD FOR PERMANENTLY FIXED AND PORTABLE
GAS ANALYSER FOR APPLICATION IN POWER TRANSFORMERS AND
REACTORS**

Unique Identifier: **240-64917195**

Revision: **2**

Page: **45 of 46**

1.8	Oxygen 3.12, Table 2	Range: 50 – 10000 ppm Accuracy : 20 ppm	
1.9	TDCG 3.12, Table 2	Accuracy: 20 ppm	
2	Moisture detection Water in oil 3.12, Table 2	Range 2 – 100% Relative Saturation or 2 ppm Accuracy: 2 ppm	
3	On Board internal data storage	Storage capacity, minimum 10 000 records	
4	Auto and self-Calibration or verification	Required, Please provide documents reflecting evidence	
5	Configuration Software		
5.1	User License All software licenses for related software for device	Eskom/NTCSA wide license with no limit on	
5.2	Operating system Software compatible with Windows.		
6	Enclosure and electrical terminations		
6.1	Main unit enclosure	Requirements of 3.7.1, enclosure rated IP 56	

CONTROLLED DISCLOSURE

**TECHNICAL STANDARD FOR PERMANENTLY FIXED AND PORTABLE
GAS ANALYSER FOR APPLICATION IN POWER TRANSFORMERS AND
REACTORS**

Unique Identifier: 240-64917195

Revision: 2

Page: 46 of 46

	Weather proof IP 56		
7	Hardware		
7.1	Computer Interface	USB	
7.2	Printing	Thermal printer	
7.3	LCD	Required	
7.4	Weight	Not more than 9kg	

CONTROLLED DISCLOSURE

When downloaded from the document management system, this document is uncontrolled and the responsibility rests with the user to ensure it is in line with the authorized version on the system. No part of this document may be reproduced in any manner or form by third parties without the written consent of National Transmission Company South Africa SOC Ltd
Reg No 2021/539129/30