



agriculture

Department:  
Agriculture  
PROVINCE OF THE EASTERN CAPE

## EASTERN CAPE PROVINCIAL GOVERNMENT

### DEPARTMENT OF AGRICULTURE

#### BID FOR THE SUPPLY AND DELIVERY OF FENCING MATERIAL TO TENTERGATE IRRIGATION SCHEME IN THE ENOCH MGIJIMA LOCAL MUNICIPALITY OF THE CHRIS HANI DISTRICT.

**SCMU8-26/27-0029**

**LOCATION: TENTERGATE VILLAGE, NTABETHEMBA**

<b>Directorate: Supply Chain Management</b> <b>DEPARTMENT OF AGRICULTURE</b> <b>Chris Hani District</b> Block H Bathandwa Ndondo Office Park Komani, 5319  Contact: Name: Ms. N. Mquqwana Telephone: 045 807 7000/ 073 434 6177 Email: Nokude.Mquqwana@ecagriculture.gov.za	<b>Directorate: Engineering Services</b> <b>DEPARTMENT OF AGRICULTURE</b> <b>Chris Hani District</b> Block H Bathandwa Ndondo Office Park Komani, 5319  Contact: Name: Z. Nhantsi Telephone: 045 807 7080/083 262 2633 Email: Zimasa.Nhantsi@ecagriculture.gov.za
<b>Closing Date:</b> 11 MAY 2026	<b>Time:</b> 11H00
<b>Tenderer:</b> _____	
<b>CSD Number:</b> _____	
<b>LOGIS Number:</b> _____	
<b>Preference Points Claimed:</b> _____	
<b>Proposed Period for Completion:</b> _____	
<b>Total of the prices inclusive of applicable taxes: R</b> _____	

# The Tender

**EASTERN CAPE PROVINCIAL GOVERNMENT  
DEPARTMENT OF AGRICULTURE**

**BID FOR THE SUPPLY AND DELIVERY OF FENCING MATERIAL TO  
TENTERGATE IRRIGATION SCHEME IN THE ENOCH MGIJIMA LOCAL  
MUNICIPALITY OF THE CHRIS HANI DISTRICT.**

## **Contents**

**Number** | **Heading**

### **The Tender**

#### **Part 1: Tendering procedures**

- 1.1 | Tender Notice and Invitation to Tender
- 1.2 | Bid Rules

#### **Part 2: Returnable documents**

- 2.1 | List of Returnable Documents

### **The Contract**

#### **Part 1: Agreement and Contract Data**

- 1.1 | Form of Offer and Acceptance
- 1.2 | Form of Guarantee

#### **Part 2: Pricing data**

- 2.1 | Pricing Instructions
- 2.2 | Bills of Quantities

#### **Part 3: Specifications**

- 3.1 | Specifications of Fencing Material and Tools

#### **Part 4: Conditions of Contract**

- 4.1 | Conditions of Contract and Special Conditions of Contract

# **PART 1: TENDERING PROCEDURES**

# 1.1

## Tender Notice and Invitation to Tender

# EASTERN CAPE PROVINCIAL GOVERNMENT

## DEPARTMENT OF AGRICULTURE

### BID FOR THE SUPPLY AND DELIVERY OF FENCING MATERIAL TO TENTERGATE IRRIGATION SCHEME IN THE ENOCH MGIJIMA LOCAL MUNICIPALITY OF THE CHRIS HANI DISTRICT.

#### T1.1 Tender Notice and Invitation to Tender

1.	<p>The Department of Agriculture, Eastern Cape Provincial Government, invites tenders for Supply and delivery of fencing material.</p> <p>The works shall include the following:</p> <ul style="list-style-type: none"><li>• Supply and deliver fencing material as per bill of quantities to the site at TENTERGATE VILLAGE, ENOCH MGIJIMA LOCAL MUNICIPALITY</li><li>• Farm Co-ordinates: TENTERGATE IRRIGATION SCHEME – <b>32°04'11.00" S</b> <b>26°27'52.41" E</b></li><li>• Material for: 18 000m long x 1.2m high x 9 Strands Stock-proof fencing</li></ul>
2.	<p>Tender documents will be available during office hours as from <b>02 April 2026</b> from the Supply Chain Office in electronic format or can be sent via email on request.</p>
3.	<p>No clarification meeting will be held. It is the responsibility of prospective tenderers to familiarize themselves with the conditions of the roads and site, as coordinates have been provided. Prospective tenderers are welcome to contact the technician responsible for the project on any information required. The technician's details are indicated at point 20 below.</p>
4.	<p>The completed tender document and any supporting documentation shall be placed in a single sealed envelope clearly marked "<b>CONTRACT NO: CH-25/26-0000: BID FOR THE SUPPLY AND DELIVERY OF FENCING MATERIAL TO TENTERGATE IRRIGATION SCHEME IN THE ENOCH MGIJIMA LOCAL MUNICIPALITY OF THE CHRIS HANI DISTRICT.</b>" And deposited in the tender box at: Supply Chain Management, Block H, Komani Office Park, Komani Hospital, Queenstown 5320, not later than <b>11:00 on 11 May 2026</b> when the tender box will close.</p> <p>Tenderers should ensure that tender documents are delivered timeously to the correct address. If the tender is late, it will not be accepted for consideration.</p>
5.	<p><b><i>Tenders will be opened in public immediately after closing time where the name of the tenderer, the financial offer, preference points claimed and proposed period for completion will be read out loud.</i></b></p>
6.	<p><b>All submitted certificates must be valid for 90 days after the Tender Closing Date.</b></p>
7.	<p>In terms of Preferential Procurement Regulation of 2022, the 80/20 preference point system is applicable.</p>

8.	<p>The Department is targeting specific goals in accordance with the Supply Chain Management Policy 2023 with reference to the Preferential Procurement Regulations 2022 The tenderers must submit verification documentation in proof of the preferential points claimed on SDB 6.1, according to table below:</p> <table border="1" data-bbox="260 315 1485 1178"> <thead> <tr> <th data-bbox="260 315 323 465">No</th> <th data-bbox="323 315 603 465">Specific Goals</th> <th data-bbox="603 315 775 465">Preference Points allocated out of the 20</th> <th data-bbox="775 315 1485 465">Documentation to be submitted by bidders to validate their claim for points</th> </tr> </thead> <tbody> <tr> <td data-bbox="260 465 323 595">1</td> <td data-bbox="323 465 603 595">An EME or QSE which is at least 51% owned by black people</td> <td data-bbox="603 465 775 595">5</td> <td data-bbox="775 465 1485 595"> <ul style="list-style-type: none"> <li>• ID Copy</li> <li>• CIPC (Company registration)</li> <li>• CSD report (the ownership status of the 2 documents must correspond in order to be awarded points)</li> </ul> </td> </tr> <tr> <td data-bbox="260 595 323 696">2</td> <td data-bbox="323 595 603 696">Located in the Province where the services will be rendered/item delivered.</td> <td data-bbox="603 595 775 696">2</td> <td data-bbox="775 595 1485 696"> <ul style="list-style-type: none"> <li>• Municipal rates account OR</li> <li>• Letter from councilor confirming residence OR</li> <li>• Lease Agreement</li> </ul> </td> </tr> <tr> <td data-bbox="260 696 323 826">3</td> <td data-bbox="323 696 603 826">An EME or QSE which is at least 51% owned by women</td> <td data-bbox="603 696 775 826">7</td> <td data-bbox="775 696 1485 826"> <ul style="list-style-type: none"> <li>• ID Copy</li> <li>• CIPC (Company registration)</li> <li>• CSD report (the ownership status of the 2 documents must correspond in order to be awarded points)</li> </ul> </td> </tr> <tr> <td data-bbox="260 826 323 956">4</td> <td data-bbox="323 826 603 956">An EME or QSE which is at least 51% owned by youth (up to 35 years of age)</td> <td data-bbox="603 826 775 956">4</td> <td data-bbox="775 826 1485 956"> <ul style="list-style-type: none"> <li>• ID Copy</li> <li>• CIPC (Company registration)</li> <li>• CSD report (the ownership status of the 2 documents must correspond in order to be awarded points)</li> </ul> </td> </tr> <tr> <td data-bbox="260 956 323 1178">5</td> <td data-bbox="323 956 603 1178">An EME or QSE which is at least 51% owned by people with disability</td> <td data-bbox="603 956 775 1178">2</td> <td data-bbox="775 956 1485 1178"> <ul style="list-style-type: none"> <li>• ID Copy</li> <li>• CIPC (Company registration)</li> <li>• CSD report (the ownership status of the 2 documents must correspond in order to be awarded points)</li> <li>• Medical certificate</li> <li>• SASSA registration or confirmation of disability from a relevant authority.</li> </ul> </td> </tr> </tbody> </table> <p>A trust, consortium or joint venture must obtain and submit documented proof for each party of such trust, consortium or joint venture.</p>	No	Specific Goals	Preference Points allocated out of the 20	Documentation to be submitted by bidders to validate their claim for points	1	An EME or QSE which is at least 51% owned by black people	5	<ul style="list-style-type: none"> <li>• ID Copy</li> <li>• CIPC (Company registration)</li> <li>• CSD report (the ownership status of the 2 documents must correspond in order to be awarded points)</li> </ul>	2	Located in the Province where the services will be rendered/item delivered.	2	<ul style="list-style-type: none"> <li>• Municipal rates account OR</li> <li>• Letter from councilor confirming residence OR</li> <li>• Lease Agreement</li> </ul>	3	An EME or QSE which is at least 51% owned by women	7	<ul style="list-style-type: none"> <li>• ID Copy</li> <li>• CIPC (Company registration)</li> <li>• CSD report (the ownership status of the 2 documents must correspond in order to be awarded points)</li> </ul>	4	An EME or QSE which is at least 51% owned by youth (up to 35 years of age)	4	<ul style="list-style-type: none"> <li>• ID Copy</li> <li>• CIPC (Company registration)</li> <li>• CSD report (the ownership status of the 2 documents must correspond in order to be awarded points)</li> </ul>	5	An EME or QSE which is at least 51% owned by people with disability	2	<ul style="list-style-type: none"> <li>• ID Copy</li> <li>• CIPC (Company registration)</li> <li>• CSD report (the ownership status of the 2 documents must correspond in order to be awarded points)</li> <li>• Medical certificate</li> <li>• SASSA registration or confirmation of disability from a relevant authority.</li> </ul>
No	Specific Goals	Preference Points allocated out of the 20	Documentation to be submitted by bidders to validate their claim for points																						
1	An EME or QSE which is at least 51% owned by black people	5	<ul style="list-style-type: none"> <li>• ID Copy</li> <li>• CIPC (Company registration)</li> <li>• CSD report (the ownership status of the 2 documents must correspond in order to be awarded points)</li> </ul>																						
2	Located in the Province where the services will be rendered/item delivered.	2	<ul style="list-style-type: none"> <li>• Municipal rates account OR</li> <li>• Letter from councilor confirming residence OR</li> <li>• Lease Agreement</li> </ul>																						
3	An EME or QSE which is at least 51% owned by women	7	<ul style="list-style-type: none"> <li>• ID Copy</li> <li>• CIPC (Company registration)</li> <li>• CSD report (the ownership status of the 2 documents must correspond in order to be awarded points)</li> </ul>																						
4	An EME or QSE which is at least 51% owned by youth (up to 35 years of age)	4	<ul style="list-style-type: none"> <li>• ID Copy</li> <li>• CIPC (Company registration)</li> <li>• CSD report (the ownership status of the 2 documents must correspond in order to be awarded points)</li> </ul>																						
5	An EME or QSE which is at least 51% owned by people with disability	2	<ul style="list-style-type: none"> <li>• ID Copy</li> <li>• CIPC (Company registration)</li> <li>• CSD report (the ownership status of the 2 documents must correspond in order to be awarded points)</li> <li>• Medical certificate</li> <li>• SASSA registration or confirmation of disability from a relevant authority.</li> </ul>																						
9.	<p>All tenderers must be registered on the National Treasury Centralized Suppliers Data Base, before the closing date of tenders and provide the information.</p> <p><b><u>Invalid or non-submission of the following documents will render the Bidder disqualified:</u></b></p> <ul style="list-style-type: none"> <li>➤ <b><u>Tax compliance status and company directors of bidders will be verified on CSD for all price quotations and bids. Hard copies of Tax Clearance Certificate and CK documents are therefore no longer needed to be attached in the bid.</u></b></li> <li>➤ <b>Company Profile</b></li> <li>➤ <b>JV Agreement (if Applicable)</b></li> <li>➤ <b>Proof of CSD registration (active &amp; recently updated)</b></li> </ul>																								
10.	Part of the works cannot be subcontracted without prior approval from the Engineer.																								
11.	The tender with the lowest price or any tender offer will not necessarily be accepted.																								
12.	<b>For a project to the value of R 3.0 million and more, a Bidder/Contractor who is not from the Eastern Cape Province, must sub-contract 25% of the contract value to a Bidder/Contractor within the Eastern Cape Province.</b>																								

13.	All tenders must be submitted on the official forms – (not to be re-typed). Telephonic, telegraphic, e-mail or facsimile will not be accepted.
14.	Failure to supply all supplementary information, certificates and documentation may result in the tender being rendered non-responsive.
15.	This tender is subject to the National Treasury General Conditions of Contract (July 2010) and, if applicable, any other Special Conditions of Contract (SCC).
16.	Bidders must submit in terms of point 14 above, the following with the bid submission: i) Proof of the CSD registration of the subcontractor(s). ii) Provide details of which items in the bill of quantities will be part of the subcontracting agreement.
17.	<b>Important:</b> <ul style="list-style-type: none"> <li>• <b>Failure to submit a fully completed and signed bid document such as Bill of Quantities, work program etc. will result in the bid not being further considered.</b></li> <li>• <b>Gross calculation errors, and omissions in the Bill of Quantities, will render the bid non-responsive.</b></li> <li>• <b>Gross under and overpricing will also render the bid as non-responsive.</b></li> </ul>
18.	<b>NB: Bidders should note that this forms part of a batch of tenders included into the DOA infrastructure program within the Eastern Cape; the employer reserves the right not to award more than TWO projects to be executed simultaneously within the province. The department as a procuring entity will conduct a risk assessment based on amounts and nature of the commodity for the final decision vs the bidder's capacity.</b>
19.	Administrative enquiries should be directed to:  Name: Ms. K. Mbuqwa Telephone: 045 807 7019/ 083 382 9352 Email: Khutala.Mbuqwa@ecagriculture.gov.za
20.	Technical enquiries should be directed to:  Name: Ms. N. Mgudlwa Telephone: 082 778 8321 Email: Nolubabalo.Mgudlwa@ecagriculture.gov.za

<b>YOU ARE HEREBY INVITED TO BID FOR REQUIREMENTS OF THE (DEPARTMENT OF AGRICULTURE)</b>					
BID NUMBER:	<b>SCMU8-26/27-0029</b>	CLOSING DATE:	<b>11May 2026</b>	CLOSING TIME:	<b>11:00</b>
DESCRIPTION	<b>BID FOR THE SUPPLY AND DELIVERY OF FENCING MATERIAL TO TENTERGATE IRRIGATION SCHEME IN THE ENOCH MGJIMA LOCAL MUNICIPALITY OF THE CHRIS HANI DISTRICT.</b>				
<b>BID RESPONSE DOCUMENTS MAY BE DEPOSITED IN THE BID BOX SITUATED AT (STREET ADDRESS)</b>					
<b>DEPARTMENT OF AGRICULTURE</b>					
<b>SUPPLY CHAIN MANAGEMENT OFFICES, Block H, Bathandwa Ndondo Office Park</b>					
<b>Komani, 5319</b>					
<b>BIDDING PROCEDURE ENQUIRIES MAY BE DIRECTED TO</b>			<b>TECHNICAL ENQUIRIES MAY BE DIRECTED TO:</b>		
CONTACT PERSON	Ms. K. Mbuqwa		CONTACT PERSON	Ms. N. Mgudlwa	
TELEPHONE NUMBER	045 807 7019/ 083 382 9352		TELEPHONE NUMBER	082 778 8321	
FACSIMILE NUMBER	045 807 7058		FACSIMILE NUMBER		
E-MAIL ADDRESS	Khutala.mbuqwa@ecagriculture.gov.za		E-MAIL ADDRESS	<a href="mailto:Nolubabalo.Mgudlwa@ecagriculture.gov.za">Nolubabalo.Mgudlwa@ecagriculture.gov.za</a>	
<b>SUPPLIER INFORMATION</b>					
NAME OF BIDDER					
POSTAL ADDRESS					
STREET ADDRESS					
TELEPHONE NUMBER	CODE		NUMBER		
CELL PHONE NUMBER					
FACSIMILE NUMBER	CODE		NUMBER		
E-MAIL ADDRESS					
VAT REGISTRATION NUMBER					
SUPPLIER COMPLIANCE STATUS	TAX COMPLIANCE SYSTEM PIN:		OR	CENTRAL SUPPLIER DATABASE No:	MAAA _____
SPECIFIC GOALS CLAIMED	TICK APPLICABLE BOX] <input type="checkbox"/> Yes <input type="checkbox"/> No		ALL SUPPORTING DOCUMENTATION FOR THE GOALS CLAIMED ATTACHED	[TICK APPLICABLE BOX] <input type="checkbox"/> Yes <input type="checkbox"/> No	
<b>[ALL DOCUMENTATION REQUIRED FOR THE CLAIM OF PREFERENCE POINTS AS PER THE SPECIFIC GOALS DETAILED IN THE EVALUATION CRITERIA.]</b>					
1.1 ARE YOU THE ACCREDITED REPRESENTATIVE IN SOUTH AFRICA FOR THE GOODS /SERVICES /WORKS OFFERED?	<input type="checkbox"/> Yes <input type="checkbox"/> No [IF YES ENCLOSE PROOF]		1.2 ARE YOU A FOREIGN BASED SUPPLIER FOR THE GOODS /SERVICES /WORKS OFFERED?	<input type="checkbox"/> Yes <input type="checkbox"/> No [IF YES, ANSWER PART B:3]	
<b>QUESTIONNAIRE TO BIDDING FOREIGN SUPPLIERS</b>					
IS THE ENTITY A RESIDENT OF THE REPUBLIC OF SOUTH AFRICA (RSA)?				<input type="checkbox"/> YES	<input type="checkbox"/> NO
DOES THE ENTITY HAVE A BRANCH IN THE RSA?				<input type="checkbox"/> YES	<input type="checkbox"/> NO

DOES THE ENTITY HAVE A PERMANENT ESTABLISHMENT IN THE RSA?

YES

NO

DOES THE ENTITY HAVE ANY SOURCE OF INCOME IN THE RSA?

YES

NO

IS THE ENTITY LIABLE IN THE RSA FOR ANY FORM OF TAXATION?

YES

NO

**IF THE ANSWER IS "NO" TO ALL OF THE ABOVE, THEN IT IS NOT A REQUIREMENT TO REGISTER FOR A TAX COMPLIANCE STATUS SYSTEM PIN CODE FROM THE SOUTH AFRICAN REVENUE SERVICE (SARS) AND IF NOT REGISTER AS PER 2.3 BELOW.**

## PART B TERMS AND CONDITIONS FOR BIDDING

<b>1. BID SUBMISSION:</b>
<p>1.1. BIDS MUST BE DELIVERED BY THE STIPULATED TIME TO THE CORRECT ADDRESS. LATE BIDS WILL NOT BE ACCEPTED FOR CONSIDERATION.</p> <p>1.2. <b>ALL BIDS MUST BE SUBMITTED ON THE OFFICIAL FORMS PROVIDED (NOT TO BE RE-TYPED) OR IN THE MANNER PRESCRIBED IN THE BID DOCUMENT.</b></p> <p>1.3. THIS BID IS SUBJECT TO THE PREFERENTIAL PROCUREMENT POLICY FRAMEWORK ACT, 2000 AND THE PREFERENTIAL PROCUREMENT REGULATIONS, THE GENERAL CONDITIONS OF CONTRACT (GCC) AND, IF APPLICABLE, ANY OTHER SPECIAL CONDITIONS OF CONTRACT.</p> <p>1.4. <b>THE SUCCESSFUL BIDDER WILL BE REQUIRED TO FILL IN AND SIGN A WRITTEN CONTRACT FORM (SBD7).</b></p>
<b>2. TAX COMPLIANCE REQUIREMENTS</b>
<p>2.1 BIDDERS MUST ENSURE COMPLIANCE WITH THEIR TAX OBLIGATIONS.</p> <p>2.2 BIDDERS ARE REQUIRED TO SUBMIT THEIR UNIQUE PERSONAL IDENTIFICATION NUMBER (PIN) ISSUED BY SARS TO ENABLE THE ORGAN OF STATE TO VERIFY THE TAXPAYER'S PROFILE AND TAX STATUS.</p> <p>2.3 APPLICATION FOR TAX COMPLIANCE STATUS (TCS) PIN MAY BE MADE VIA E-FILING THROUGH THE SARS WEBSITE WWW.SARS.GOV.ZA.</p> <p>2.4 BIDDERS MAY ALSO SUBMIT A PRINTED TCS CERTIFICATE TOGETHER WITH THE BID.</p> <p>2.5 IN BIDS WHERE CONSORTIA / JOINT VENTURES / SUB-CONTRACTORS ARE INVOLVED; EACH PARTY MUST SUBMIT A SEPARATE TCS CERTIFICATE / PIN / CSD NUMBER.</p> <p>2.6 WHERE NO TCS PIN IS AVAILABLE BUT THE BIDDER IS REGISTERED ON THE CENTRAL SUPPLIER DATABASE (CSD), A CSD NUMBER MUST BE PROVIDED.</p> <p>2.7 NO BIDS WILL BE CONSIDERED FROM PERSONS IN THE SERVICE OF THE STATE, COMPANIES WITH DIRECTORS WHO ARE PERSONS IN THE SERVICE OF THE STATE, OR CLOSE CORPORATIONS WITH MEMBERS PERSONS IN THE SERVICE OF THE STATE."</p>

**NB: FAILURE TO PROVIDE / OR COMPLY WITH ANY OF THE ABOVE PARTICULARS MAY RENDER THE BID INVALID.**

SIGNATURE OF BIDDER:

.....

CAPACITY UNDER WHICH THIS BID IS SIGNED:

.....

(Proof of authority must be submitted e.g. company resolution)

DATE:

.....

# 1.2

## Bid Rules

**EASTERN CAPE PROVINCIAL GOVERNMENT  
DEPARTMENT OF AGRICULTURE**

**BID FOR THE SUPPLY AND DELIVERY OF FENCING MATERIAL TO  
TENTERGATE IRRIGATION SCHEME IN THE ENOCH MGIJIMA LOCAL  
MUNICIPALITY OF THE CHRIS HANI DISTRICT.**

## **1.1 Tender Notice and Invitation to Tender**

### **1.1.1 Tender Notice**

The Department of AGRICULTURE, Eastern Cape Provincial Government, invites tenders for Supply and delivery of fencing material.

The works shall include the following:

- Supply and deliver fencing material as per bill of quantities to the site at **TENTERGATE VILLAGE, ENOCH MGIJIMA LOCAL MUNICIPALITY**
- Farm Co-ordinates:
- TENTERGATE IRRIGATION SCHEME – **32°04'11.00" S  
26°27'52.41" E**

### **TENDER RULES AND REQUIREMENTS:**

#### **1. Bid Documents**

The Bidder shall satisfy himself that the documents received are correct, complete and sufficient to be the basis of a *bona fide* tender. Bidders shall check the numbers of the pages and satisfy themselves that none are missing or duplicated. No liability shall be accepted in regard to claims arising from the fact that pages are missing or duplicated. Should a Bidder not accept that the documents issued can form the basis of a *bona fide* bid, the Deputy Director SCM shall be requested to correct the discrepancy, ambiguity, missing or illegible information prior to the submission of bids? The submission of a *bona fide* bid shall absolve the Employer, Deputy Director SCM, from any liability whatsoever for any error in a bid due to the foregoing.

**Furthermore, no request for the revision of the Bid Sum as a result of such error shall be considered by the Employer after the closing date and time set for the submission of bids.**

#### **2. Submission of Bids**

Clearly marked bids in sealed envelopes shall be submitted at the place and **before the closing time** stated in the Bid Notice.

Electronic, faxed, or telegraphic bids will not be accepted.

#### **3. Deposit on Documents**

The deposit on bid documents will not be refunded.

#### **4. Notice to Bidders**

Should any additions or alterations to the documents as issued to bidders be deemed necessary prior to the date for submission of bids, these will be issued to bidders in the form of Notices to Bidders and these will form part of the bid document.

The Notices to Bidders shall be completed where applicable by bidders, signed, dated and returned with the bid documents.

## 5. Completion of Bid Documents

Bidders will only be considered on receipt of this bid document correctly completed with all insertions in black ink.

Bidders are required to complete and sign, where applicable, all forms to be completed by bidder.

**Bidders are required to indicate the details of their offer at the space provided in the PRICING SCHEDULE (SBD 3.1) and Contract Form (SBD 7.1) included in this document.**

No unauthorized alteration shall be made to the document. Mistakes made by the bidder in the completion of the **SERVICES PARTICULAR SPECIFICATIONS OR PRICING SCHEDULE**, forms, etc. shall not be erased nor erasing fluid used. A line shall be drawn through the incorrect entry and the correct entry shall be written above and the correction initialed by the bidder.

All information is to be provided on the forms provided in Bid Document. Should the provided space be insufficient, additional information should be attached to the back of the appropriate forms.

Failure to comply with any of the foregoing clauses may invalidate the bid.

Bids may also be rejected if they show any additional items not originally included in the bid documents, irregularities of any kind in either the bid form or other documents, or if the amounts tendered in the bid form are obviously unbalanced and the bidder, after having been called upon to adjust same in a reasonable manner, **fails to do so within a period of seven days of having received notification to that effect.**

## 6. Signing of Bids

The bid must be signed by a person duly authorized to do so. In the case of a bid being submitted on behalf of a Company, Close Corporation, Partnership or Joint Venture, such bid shall be accompanied by a certified copy of a resolution of the Board of Directors of such Company, Close Corporation or other suitable authority in the case of a Partnership or Joint Venture, in terms of which the nominee is authorised to sign on behalf of the business entity.

A bid submitted by a corporation must bear the seal of the corporation and be attested by its CEO. Bidders submitted by joint ventures of two or more firms must be accompanied by the document of formation of the joint venture, authenticated by a notary public or other official deputed to witness sworn statements, in which is defined precisely the conditions under which the joint venture will function, its period of duration, the persons authorized to represent and obligate it, the participation of the several firms forming the joint venture, and any other information necessary to permit a full appraisal of its functioning.

The joint venture documentation is also to clearly state that all its parties will remain severally and jointly bound for the duration of the defects liability period, as well as setting out how matters will be dealt with that may arise as latent defects once the joint venture has dissolved. If due to any unforeseen reasons the joint venture dissolves during the defects liability period, the agreement must clearly state how the liability will be dealt with in terms of honoring all the responsibilities it may still have with regards to the due performance of all contractual issues that could arise.

## 7. ALLOWANCE FOR CONTRACT PRICE ADJUSTMENT

There will be **no allowance for Contract Price Adjustment.**

## 8. SCHEDULE OF QUANTITIES

Bidders shall note that all quantities in the schedule are provisional and substantial alterations to individual quantities could occur.

Should the bidder be in doubt as to the description of any items, or the meaning of any measurement or payment clause, clarification shall be obtained in writing from the Chief Engineer and this correspondence shall be submitted with the bid.

The Chief Engineer will not consider claims submitted on the basis of misunderstanding of or omissions from the description of scheduled items or measurement or payment clauses.

#### **9. BID ALL INCLUSIVE**

Include in the rates, prices, and the tendered total of the prices (if any) all duties, taxes (except Value Added Tax (VAT), and other levies payable by the successful tenderer, such duties, taxes and levies being those applicable 14 days before the closing time stated in the tender data. Bidders are not entitled add VAT to the tender price, nor to claim the VAT if they are not VAT registered vendors.

#### **10. PERIOD OF VALIDITY OF BIDS**

The period of validity of bids shall be **90 days** from the closing date for submission of bids.

Should the bidder withdraw or retract his bid within the period of validity, or should the bidder fail to take up the Contract when notified in accordance with the General Conditions of Contract, or fail to furnish approved sureties or insurances within the period specified, then he shall pay either the difference between his bid and a less favourable bid accepted, or if the Employer decides to invite fresh bids, all additional expenses which the Employer has to incur in this regard, as well as any difference between his bid and the accepted new bid. The Employer may, however, fully or partly exempt a bidder from the provisions of this sub rule if he is of the opinion that the circumstances justify the exemption.

#### **11. EVIDENCE OF SUPPLIERS / CONTRACTORS / CONSULTANTS EXPERIENCE**

Bidders shall fill in details of goods and services supplied or work previously and successfully executed by them of a similar nature to that for which this bid is being submitted in the Form provided in this document. In the case of joint ventures or consortiums, the work experience of each firm is to be submitted.

Failure to provide this information may deem the bid as being submitted by an inexperienced bidder and it may be rejected for such reason. If the Bidder having been called upon to provide information in a reasonable manner, **fails to do so within a period of seven (7) days of having received notification to that effect.**

#### **12. INSURANCES**

In accordance with Clause 7 of the General Conditions of Contract and Special conditions of Contract, the successful bidder will be required to provide to the satisfaction of the employer a copy of the insurance documentation showing that the insurance policies required in terms of the General Conditions of Contract have been taken out and provide proof of payment of the premiums for the insurances required.

#### **13. DECLARATION OF GOOD STANDING REGARDING TAX**

Bidders are not required to submit an original Tax Clearance Certificate with their bid as this will be verified on CSD.

#### **14. FINANCIAL INVESTIGATION**

The Employer reserves the right to appoint an accountant to report on the financial resources of any bidder. The bidder shall provide all reasonable help in such investigation and ensure that the necessary documentation is provided within seven days of being called upon to do so.

## **15. AMENDMENTS TO BID BY EMPLOYER**

### **15.1 Arithmetical Errors**

The Employer reserves the right to correct arithmetical or other errors in the extension of rates and totals in the bid. The bidder will be informed about the effect of any corrections on his bid sum prior to acceptance of the bid. **In no case will the BID SUM be adjusted when such errors are corrected.**

### **15.2 Imbalance in Tender Rates**

In the event of there being any rate or rates which are declared to be unacceptable by the Employer for reasons which the Employer will indicate, the bidder will be requested -

- (a) to justify any specific rate or rates, i.e. to give a financial breakdown of how such rate or rates were obtained,
- (b) and subsequently to consider amending and adjusting such rate or rates while retaining the bid sum derived under sub-clause 15.1 unchanged and fixed. It must be understood that in the event of the **bidder refusing to adjust any rate or rates to the satisfaction of the Employer, such refusal may prejudice his bid.**

#### **Important:**

- **Gross calculation errors, and omissions in the Bill of Quantities, will render the bid non-responsive.**
- **Gross under and overpricing will also render the bid as non-responsive.**

## **16. COST OF BID**

Any expenses or losses, which may be incurred by the bidders in the preparation and submission of their bids, shall be for the account of the bidders.

## **18. DISQUALIFICATION OF BID**

The bid of any bidder who has not conformed to these Bid Rules and the instructions reflected in the official Bid Notice or pricing instruction may be disqualified at the discretion of the Employer.

## **19. DELEGATION OF AUTHORITY BY EMPLOYER**

The Employer may delegate any power vested in him by virtue of these Bid Rules to an officer or employee of the Employer.

## **20. BID RULES ARE BINDING**

The bid rules as well as the instructions given in the official Bid Notice, Scope of works and Pricing Instruction, shall be binding on all bidders submitting bids for the services stated in the bid documents.

## **21. BID ACCEPTANCE**

The Employer does not bind himself to accept the lowest or any bid. The Employer may award different items to different bidders.

## 22. ADJUDICATION OF BIDS

### 22.1 Bidders Qualifying for Adjudication

Only bidders meeting the following requirements will be eligible for adjudication in terms of the preference point system:

- (i) Bidder has complied with all the bid rules.
- (ii) The tender offer is signed by a person authorized to sign on behalf of the Tenderer.
- (iii) The Tenderer or a competent authorised representative of the Service provider/ Consultant/Contractor who submitted the tender has attended the compulsory clarification meeting and site verification inspection.
- (iv) Bidder has compiled all the declarations. (SBD 4 & 6.1);
- (v) The Tenderer or any of its directors is not listed on the Register of Tender Defaulters in terms of the Prevention and Combating of Corrupt Activities Act of 2004 as a person prohibited from doing business with the public sector;
- (vi) The Tenderer has not:
  - abused the Employer's Supply Chain Management System;
  - or failed to perform on any previous contract and has been given a written notice to this effect;
- (vii) Bidder has adequate resources available with regards to financial resources and personnel;
- (viii) The Bidder has completed the Compulsory Enterprise Questionnaire and there are no conflicts of interest which may impact on the tenderer's ability to perform the contract in the best interests of the employer or potentially compromise the tender process;
- (ix) Having completed and attached the agreement form with a manufacturer / supplier / importer / contractor to deal, repair equipment and execute services.
- (x) Having submitted a balanced bid with respect to unit rates and sums.
- (xi) Any bidder from **outside the Province, must sub-contract a minimum of 25% of the work contract value to a nominated Local Service provider. The bidder must procure input materials from Local Suppliers where possible and appoint unskilled labour from within the locality of the project if labour is needed.**
- (xii) Bidders must attach documentation to proof preferential points claimed.

In order to ensure that the procurement point allocation for the financial components is not distorted by unreasonably low prices and to protect the integrity of the process, only bids that is considered to be reasonable, will be evaluated.

### 22.2 Procurement Points System

Bids will be adjudicated using the 80/20- or 90/10-point's formula.

- the 80/20 system for requirements with a Rand value of up to R 50 000 000 (all applicable taxes included); and
- the 90/10 system for requirements with a Rand value above R 50 000 000 (all applicable taxes included).

### 22.3 Financial Components Max 80 points (80/20 formula) Max 90 points (90/10 formula)

The points scored for the financial component will be calculated using the formula as set out in SBD 6.1

### 22.4 Targeted Specific Goals Max 20 points (80/20 formula) Max 10 points (90/10 formula)

The Department is targeting specific goals in accordance with the Supply Chain Management Policy 2023 with reference to the Preferential Procurement Regulations 2022. The tenderers must submit verification documentation in proof of the preferential points claimed on SDB 6.1, according to table below:

**Bidders must submit documentation to proof preferential points claimed.**

**A trust, consortium or joint venture must obtain and submit documented proof for each party of such trust, consortium or joint venture.**

### **23. PROJECT COMPLETION TIME FRAME**

The Bidder shall complete the works within **31 days** after the receipt of order.

### **24. PENALTY**

The Bidder's attention is drawn to the forms which contain a declaration statement.

The Employer reserves the right to take legal action against bidders who tendered information that are later found to be incorrect.

If the Bidder fails to deliver any Services/works within the period specified in the contract, or within any extension thereof granted by the Employer, the purchaser shall, without prejudice to its other remedies under the contract, deduct from the contract price, as a penalty, a sum calculated on the delivered price of the delayed goods or unperformed services using the current prime interest rate calculated for each day of the delay until actual delivery or performance. The purchaser may also consider termination of the contract pursuant to GCC Clause 23.

### **25. LEGAL ASPECTS**

If, after the date of the Contract Agreement, the cost or duration of the services is altered as a result of changes in, or additions to any statute, regulation or by-law, or in the requirements of any authority having jurisdiction over any matter in respect of the Contract, then the agreed remuneration and time for completion shall be adjusted in order to reflect the impact of those changes.



# PART 2 RETURNABLE DOCUMENTS

## EASTERN CAPE PROVINCIAL GOVERNMENT DEPARTMENT OF AGRICULTURE

### BID FOR THE SUPPLY AND DELIVERY OF FENCING MATERIAL TO TENTERGATE IRRIGATION SCHEME IN THE ENOCH MGIJIMA LOCAL MUNICIPALITY OF THE CHRIS HANI DISTRICT.

#### 2.1 List of Returnable Documents

The tenderer must complete the following returnable documents:

##### 1 Returnable Schedules required only for tender evaluation purposes.

- Certificate of authority for joint ventures (where applicable)
- Compulsory Enterprise Questionnaire
- Record of Addenda to Tender Documents
- Schedule of the Tenderer's Experience

##### 2 Other documents required only for tender evaluation purposes.

- Proof of registration on the CSD and copy of active and updated certificate attached.
- Documented proof of points claimed for Specific goals.

##### 3 Returnable Schedules that will be incorporated into the contract.

- Preferencing Schedule SBD 6.1

#### **4 Other documents that will be incorporated into the contract.**

- Declaration of validity of information.
- Declaration of Interest - SBD 4.
- Certificate of tenderer's visit to clarification/site meeting.
- Tenderer's Banking detail confirmation.
- Surety and Bank details (if needed).
- Certificate: Confirmation of supply arrangements between the bidder and his/her supplier
- POPI Consent Form

#### **5 The offer portion of the C1.1 Offer and Acceptance**

#### **6 Bills of quantities**

# Certificate of Authority for Joint Ventures

This Returnable Schedule is to be completed by joint ventures.

We, the undersigned, are submitting this tender offer in Joint Venture and hereby authorise Mr/Ms \_\_\_\_\_ authorised signatory of the company \_\_\_\_\_, acting in the capacity of lead partner, to sign all documents in connection with the tender offer and any contract resulting from it on our behalf.

NAME OF FIRM	ADDRESS	DULY AUTHORISED SIGNATORY
Lead partner		Signature. .... Name. .... Designation. ....
		Signature. .... Name. .... Designation. ....
		Signature. .... Name. .... Designation. ....
		Signature. .... Name. .... Designation. ....

# Compulsory Enterprise Questionnaire

The following particulars must be furnished. In the case of a joint venture, **separate** enterprise questionnaires in respect of each partner must be completed and submitted.

**Section 1: Name of enterprise:** .....

**SECTION 3: VAT registration number, if any:**  
.....

**Section 3: CIDB registration number, if any:** .....

**Section 4: Particulars of sole proprietors and partners in partnerships**

Name*	Identity number*	Personal income tax number*

\* Complete only if sole proprietor or partnership and attach separate page if more than 3 partners

**Section 5: Particulars of companies and close corporations**

Company registration number. ....  
 Close corporation number. ....  
 Tax reference number. ....

**Section 6: Record in the service of the state**

Indicate by marking the relevant boxes with a cross, if any sole proprietor, partner in a partnership or director, manager, principal shareholder or stakeholder in a company or close corporation is currently or has been within the last 12 months in the service of any of the following:

- |  |   |
|--|---|
| <input type="checkbox"/> a member of any municipal council<br><input type="checkbox"/> a member of any provincial legislature<br><input type="checkbox"/> a member of the National Assembly or the National Council of Province<br><input type="checkbox"/> a member of the board of directors of any municipal entity<br><input type="checkbox"/> an official of any municipality or municipal entity | <input type="checkbox"/> an employee of any provincial department, national or provincial public entity or constitutional institution within the meaning of the Public Finance Management Act, 1999 (Act 1 of 1999)<br><input type="checkbox"/> a member of an accounting authority of any national or provincial public entity<br><input type="checkbox"/> an employee of Parliament or a provincial legislature |
|--|---|

**If any of the above boxes are marked, disclose the following:**

Name of sole proprietor, partner, director, manager, principal shareholder or stakeholder	Name of institution, public office, board or organ of state and position held	Status of service (tick appropriate column)	
		Current	Within last 12 months

\*insert separate page if necessary

**Section 7: Record of spouses, children and parents in the service of the state**

Indicate by marking the relevant boxes with a cross, if any spouse, child or parent of a sole proprietor, partner in a partnership or director, manager, principal shareholder or stakeholder in a company or close corporation is currently or has been within the last 12 months been in the service of any of the following:

- a member of any municipal council
- a member of any provincial legislature
- a member of the National Assembly or the National Council of Province
- a member of the board of directors of any municipal entity
- an official of any municipality or municipal entity
- an employee of any provincial department, national or provincial public entity or constitutional institution within the meaning of the Public Finance Management Act, 1999 (Act 1 of 1999)
- a member of an accounting authority of any national or provincial public entity
- an employee of Parliament or a provincial legislature

Name of spouse, child or parent	Name of institution, public office, board or organ of state and position held	Status of service (tick appropriate column)	
		Current	Within last 12 months

\*insert separate page if necessary

The undersigned, who warrants that he / she is duly authorised to do so on behalf of the enterprise:

- i) authorizes the Employer to obtain a tax clearance certificate from the South African Revenue Services that my / our tax matters are in order;
- ii) confirms that the neither the name of the enterprise or the name of any partner, manager, director or other person, who wholly or partly exercises, or may exercise, control over the enterprise appears on the Register of Tender Defaulters established in terms of the Prevention and Combating of Corrupt Activities Act of 2004;
- iii) confirms that no partner, member, director or other person, who wholly or partly exercises, or may exercise, control over the enterprise appears, has within the last five years been convicted of fraud or corruption;
- iv) confirms that I / we are not associated, linked or involved with any other tendering entities submitting tender offers and have no other relationship with any of the tenderers or those responsible for compiling the scope of work that could cause or be interpreted as a conflict of interest; and
- v) confirms that the contents of this questionnaire are within my personal knowledge and are to the best of my belief both true and correct.

Signed \_\_\_\_\_ Date \_\_\_\_\_

Name \_\_\_\_\_ Position \_\_\_\_\_

Enterprise name \_\_\_\_\_

# Proposed amendments and qualifications

The Tenderer should record any deviations or qualifications he may wish to make to the tender documents in this Returnable Schedule. Alternatively, a tenderer may state such deviations and qualifications in a covering letter to his tender and reference such letter in this schedule.

The Tenderer's attention is drawn to clause C.3.8 of the Standard Conditions of Tender referenced in the Tender Data regarding the employer's handling of material deviations and qualifications.

Page	Clause or item	Proposal

Signed ..... Date .....

Name ..... Position .....

Tenderer .....

## Schedule of The Tenderer's Experience: Completed Projects

The following is a statement of similar work successfully executed by myself / ourselves over the past five (5) years:

Employer, contact person and telephone number.	Description of contract	Value of work inclusive of VAT (Rand)	Date contract started	Date contract completed

Signed .....

Date .....

Name .....

Position .....

Tenderer \_\_\_\_\_

## Schedule of The Tenderer’s Experience: – Current Projects

Tenderers must submit a max of one-page description of projects under execution/ on hold/ or just awarded/ or towards completion (if they exist). **Attach an Appointment letter for each of the projects provided.**

The description of each project must include the following information:

1. Essential introductory information:
  - 1.1 Name of project.
  - 1.2 Name of client.
  - 1.3 Contact details of client. (including telephone numbers and email addresses) of currently contactable references.
  - 1.4 The period during which the project was performed, and also, if this is different.
  - 1.5 Cost of supply and delivery and/or contract value (making it clear in broad terms what this cost/value purchased, and to what extent (if any) this cost/value was part of a larger project).

NO.	NAME OF PROJECT.	NAME OF CLIENT.	CONTACT DETAILS OF CLIENT.	PROJECT VALUE	STAGE OF PROJECT
1					
2					
3					

The undersigned, who warrants that she/ he is duly authorised to do so on behalf of the enterprise, confirms that the content of this schedule that presented by the tenderer are within my personal knowledge and are to the best of my knowledge both true and correct.

**SIGNATURE OF TENDERER:** .....  
*(of person authorised to sign on behalf of the Tenderer)*

**DATE:** .....

## **Contractors Certificate of registration on CSD**

*[The tenderer shall submit the Contractor's Certificate of Registration on the CSD. Failure to submit the certificate with the tender document will lead to the conclusion that the tenderer is not registered on the National Treasury Central Suppliers Database and therefore not eligible to tender].*

**PREFERENCE POINTS CLAIM FORM IN TERMS OF THE PREFERENTIAL PROCUREMENT REGULATIONS 2022**

This preference form must form part of all tenders invited. It contains general information and serves as a claim form for preference points for specific goals.

**NB: BEFORE COMPLETING THIS FORM, TENDERERS MUST STUDY THE GENERAL CONDITIONS, DEFINITIONS AND DIRECTIVES APPLICABLE IN RESPECT OF THE TENDER AND PREFERENTIAL PROCUREMENT REGULATIONS, 2022**

**1. GENERAL CONDITIONS**

1.1 The following preference point systems are applicable to invitations to tender:

- the 80/20 system for requirements with a Rand value of up to R50 000 000 (all applicable taxes included); and
- the 90/10 system for requirements with a Rand value above R50 000 000 (all applicable taxes included).

**1.2 To be completed by the organ of state**

*(delete whichever is not applicable for this tender).*

The applicable preference point system for this tender is the **80/20** preference point system.

1.3 Points for this tender (even in the case of a tender for income-generating contracts) shall be awarded for:

- (a) Price; and
- (b) Specific Goals.

**1.4 To be completed by the organ of state:**

The maximum points for this tender are allocated as follows:

	POINTS
<b>PRICE</b>	80
<b>SPECIFIC GOALS</b>	20
<b>Total points for Price and SPECIFIC GOALS</b>	<b>100</b>

1.5 Failure on the part of a tenderer to submit proof or documentation required in terms of this tender to claim points for specific goals with the tender, will be interpreted to mean that preference points for specific goals are not claimed.

1.6 The organ of state reserves the right to require of a tenderer, either before a tender is adjudicated or at any time subsequently, to substantiate any claim in regard to preferences, in any manner required by the organ of state.

**2. DEFINITIONS**

- (a) **“tender”** means a written offer in the form determined by an organ of state in response to an invitation to provide goods or services through price quotations, competitive tendering process or any other method envisaged in legislation;
- (b) **“price”** means an amount of money tendered for goods or services, and includes all applicable taxes less all unconditional discounts;
- (c) **“rand value”** means the total estimated value of a contract in Rand, calculated at the time of bid invitation, and includes all applicable taxes;
- (d) **“tender for income-generating contracts”** means a written offer in the form determined by an organ of state in response to an invitation for the origination of income-generating contracts through any method envisaged in legislation that will result in a legal agreement between the organ of state and a third party that produces revenue for the organ of state, and includes, but is not limited to, leasing and disposal of assets and concession contracts, excluding direct sales and disposal of assets through public auctions; and
- (e) **“the Act”** means the Preferential Procurement Policy Framework Act, 2000 (Act No. 5 of 2000).

### 3. FORMULAE FOR PROCUREMENT OF GOODS AND SERVICES

#### 3.1. POINTS AWARDED FOR PRICE

##### 3.1.1 THE 80/20 OR 90/10 PREFERENCE POINT SYSTEMS

A maximum of 80 or 90 points is allocated for price on the following basis:

$$\begin{array}{ccc}
 \mathbf{80/20} & \mathbf{or} & \mathbf{90/10} \\
 \\
 \mathbf{Ps} = \mathbf{80} \left( \mathbf{1} - \frac{\mathbf{Pt} - \mathbf{Pmin}}{\mathbf{Pmin}} \right) & \mathbf{or} & \mathbf{Ps} = \mathbf{90} \left( \mathbf{1} - \frac{\mathbf{Pt} - \mathbf{Pmin}}{\mathbf{Pmin}} \right)
 \end{array}$$

Where

- Ps = Points scored for price of tender under consideration
- Pt = Price of tender under consideration
- Pmin = Price of lowest acceptable tender

#### 3.2. FORMULAE FOR DISPOSAL OR LEASING OF STATE ASSETS AND INCOME GENERATING PROCUREMENT

##### 3.2.1. POINTS AWARDED FOR PRICE

A maximum of 80 or 90 points is allocated for price on the following basis:

$$\begin{array}{ccc}
 \mathbf{80/20} & \mathbf{or} & \mathbf{90/10} \\
 \\
 \mathbf{Ps} = \mathbf{80} \left( \mathbf{1} + \frac{\mathbf{Pt} - \mathbf{Pmax}}{\mathbf{Pmax}} \right) & \mathbf{or} & \mathbf{Ps} = \mathbf{90} \left( \mathbf{1} + \frac{\mathbf{Pt} - \mathbf{Pmax}}{\mathbf{Pmax}} \right)
 \end{array}$$

Where

- Ps = Points scored for price of tender under consideration
- Pt = Price of tender under consideration
- Pmax = Price of highest acceptable tender

#### 4. POINTS AWARDED FOR SPECIFIC GOALS

4.1. In terms of Regulation 4(2); 5(2); 6(2) and 7(2) of the Preferential Procurement Regulations, preference points must be awarded for specific goals stated in the tender. For the purposes of this tender the tenderer will be allocated points based on the goals stated in table 1 below as may be supported by proof/ documentation stated in the conditions of this tender:

4.2. In cases where organs of state intend to use Regulation 3(2) of the Regulations, which states that, if it is unclear whether the 80/20 or 90/10 preference point system applies, an organ of state must, in the tender documents, stipulate in the case of—

(a) an invitation for tender for income-generating contracts, that either the 80/20 or 90/10 preference point system will apply and that the highest acceptable tender will be used to determine the applicable preference point system; or

(b) any other invitation for tender, that either the 80/20 or 90/10 preference point system will apply and that the lowest acceptable tender will be used to determine the applicable preference point system,

then the organ of state must indicate the points allocated for specific goals for both the 90/10 and 80/20 preference point system.

**Table 1: Specific goals for the tender and points claimed are indicated per the table below.**

*(Note to organs of state: Where either the 90/10 or 80/20 preference point system is applicable, corresponding points must also be indicated as such.)*

*Note to tenderers: The tenderer must indicate how they claim points for each preference point system.)*

The specific goals allocated points in terms of this tender	Number of points allocated (90/10 system) (To be completed by the organ of state)	Number of points allocated (80/20 system) (To be completed by the organ of state)	Number of points claimed (90/10 system) (To be completed by the tenderer)	Number of points claimed (80/20 system) (To be completed by the tenderer)
An EME or QSE which is at least 51% owned by <b>black people</b>	N.A.	5		
<b>Located</b> in the Province where the services will be rendered/item delivered.	N.A.	2		
An EME or QSE which is at least 51% owned by <b>women</b>	N.A.	7		
An EME or QSE which is at least 51% owned by <b>youth (up to 35 years of age)</b>	N.A.	4		
An EME or QSE which is at least 51% owned by people with <b>disability</b>	N.A.	2		
<b>Total</b>	N.A.	20		

**DECLARATION WITH REGARD TO COMPANY/FIRM**

4.3. Name of company/firm.....

4.4. Company registration number: .....

4.5. TYPE OF COMPANY/ FIRM

- Partnership/Joint Venture / Consortium
- One-person business/sole propriety
- Close corporation
- Public Company
- Personal Liability Company
- (Pty) Limited
- Non-Profit Company
- State Owned Company

[TICK APPLICABLE BOX]

4.6. I, the undersigned, who is duly authorised to do so on behalf of the company/firm, certify that the points claimed, based on the specific goals as advised in the tender, qualifies the company/ firm for the preference(s) shown and I acknowledge that:

- i) The information furnished is true and correct;
- ii) The preference points claimed are in accordance with the General Conditions as indicated in paragraph 1 of this form;
- iii) In the event of a contract being awarded as a result of points claimed as shown in paragraphs 1.4 and 4.2, the contractor may be required to furnish documentary proof to the satisfaction of the organ of state that the claims are correct;
- iv) If the specific goals have been claimed or obtained on a fraudulent basis or any of the conditions of contract have not been fulfilled, the organ of state may, in addition to any other remedy it may have –
  - (a) disqualify the person from the tendering process;
  - (b) recover costs, losses or damages it has incurred or suffered as a result of that person’s conduct;
  - (c) cancel the contract and claim any damages which it has suffered as a result of having to make less favourable arrangements due to such cancellation;
  - (d) recommend that the tenderer or contractor, its shareholders and directors, or only the shareholders and directors who acted on a fraudulent basis, be restricted from obtaining business from any organ of state for a period not exceeding 10 years, after the *audi alteram partem* (hear the other side) rule has been applied; and
  - (e) forward the matter for criminal prosecution, if deemed necessary.

.....  
**SIGNATURE(S) OF TENDERER(S)**

**SURNAME AND NAME:** .....

**DATE:** .....

**ADDRESS:** .....

.....

.....

.....

The Tenderer's Reference

## Declaration (Validity of Information Provided)

I ..... declare that the information provided is true and correct, the signature to the tender document is duly authorised and documentary proof regarding any tendering issue will, when required, be submitted to the satisfaction of the Department of AGRICULTURE.

DATE . ..... SIGNATURE OF DECLARER .....

POSITION OF DECLARER .....

NAME OF COMPANY OR TENDERER .....

Should the tenderer have, in the opinion of the Department of AGRICULTURE, acted fraudulently illegally, in bad faith or in any improper manner, misrepresented itself with regard to the tender, then the Department of AGRICULTURE may, in its sole discretion:

- \* Ignore any tenders without advising the tenderer thereof
- \* Cancel the contract without prejudice to any legal rights the Department of AGRICULTURE may have

**Should the tenderer disregard this or conduct affairs in a way that transgresses from good business practices, this could seriously impair future business relations between the Department of AGRICULTURE and such tenderer.**

**BIDDER’S DISCLOSURE**

**1. PURPOSE OF THE FORM**

Any person (natural or juristic) may make an offer or offers in terms of this invitation to bid. In line with the principles of transparency, accountability, impartiality, and ethics as enshrined in the Constitution of the Republic of South Africa and further expressed in various pieces of legislation, it is required for the bidder to make this declaration in respect of the details required hereunder.

Where a person/s are listed in the Register for Tender Defaulters and / or the List of Restricted Suppliers, that person will automatically be disqualified from the bid process.

**2. Bidder’s declaration**

2.1 Is the bidder, or any of its directors / trustees / shareholders / members / partners or any person having a controlling interest<sup>1</sup> in the enterprise, employed by the state? **YES/NO**

2.1.1 If so, furnish particulars of the names, individual identity numbers, and, if applicable, state employee numbers of sole proprietor/ directors / trustees / shareholders / members/ partners or any person having a controlling interest in the enterprise, in table below.

Full Name	Identity Number	Name of State institution

---

<sup>1</sup> the power, by one person or a group of persons holding the majority of the equity of an enterprise, alternatively, the person/s having the deciding vote or power to influence or to direct the course and decisions of the enterprise.

1.2 Do you, or any person connected with the bidder, have a relationship with any person who is employed by the procuring institution? **YES/NO**

2.2.1 If so, furnish particulars:  
.....  
.....

2.3 Does the bidder or any of its directors / trustees / shareholders / members / partners or any person having a controlling interest in the enterprise have any interest in any other related enterprise whether or not they are bidding for this contract? **YES/NO**

2.3.1 If so, furnish particulars:  
.....  
.....

**3 DECLARATION**

I, the undersigned, (name)..... in submitting the accompanying bid, do hereby make the following statements that I certify to be true and complete in every respect:

- 3.1 I have read and I understand the contents of this disclosure;
- 3.2 I understand that the accompanying bid will be disqualified if this disclosure is found not to be true and complete in every respect;
- 3.3 The bidder has arrived at the accompanying bid independently from, and without consultation, communication, agreement or arrangement with any competitor. However, communication between partners in a joint venture or consortium<sup>2</sup> will not be construed as collusive bidding.
- 3.4 In addition, there have been no consultations, communications, agreements or arrangements with any competitor regarding the quality, quantity, specifications, prices, including methods, factors or formulas used to calculate prices, market allocation, the intention or decision to submit or not to submit the bid, bidding with the intention not to win the bid and conditions or delivery particulars of the products or services to which this bid invitation relates.
- 3.4 The terms of the accompanying bid have not been, and will not be, disclosed by the bidder, directly or indirectly, to any competitor, prior to the date and time of the official bid opening or of the awarding of the contract.

<sup>2</sup> Joint venture or Consortium means an association of persons for the purpose of combining their expertise, property, capital, efforts, skill and knowledge in an activity for the execution of a contract.

3.5 There have been no consultations, communications, agreements or arrangements made by the bidder with any official of the procuring institution in relation to this procurement process prior to and during the bidding process except to provide clarification on the bid submitted where so required by the institution; and the bidder was not involved in the drafting of the specifications or terms of reference for this bid.

3.6 I am aware that, in addition and without prejudice to any other remedy provided to combat any restrictive practices related to bids and contracts, bids that are suspicious will be reported to the Competition Commission for investigation and possible imposition of administrative penalties in terms of section 59 of the Competition Act No 89 of 1998 and or may be reported to the National Prosecuting Authority (NPA) for criminal investigation and or may be restricted from conducting business with the public sector for a period not exceeding ten (10) years in terms of the Prevention and Combating of Corrupt Activities Act No 12 of 2004 or any other applicable legislation.

I CERTIFY THAT THE INFORMATION FURNISHED IN PARAGRAPHS 1, 2 and 3 ABOVE IS CORRECT.  
I ACCEPT THAT THE STATE MAY REJECT THE BID OR ACT AGAINST ME IN TERMS OF PARAGRAPH 6 OF PFMA SCM INSTRUCTION 03 OF 2021/22 ON PREVENTING AND COMBATING ABUSE IN THE SUPPLY CHAIN MANAGEMENT SYSTEM SHOULD THIS DECLARATION PROVE TO BE FALSE.

.....	.....
Signature	Date
.....	.....
Position	Name of bidder

DEPARTMENT OF AGRICULTURE

BID FOR THE SUPPLY AND DELIVERY OF FENCING MATERIAL TO TENTERGATE IRRIGATION SCHEME IN THE ENOCH MGIJIMA LOCAL MUNICIPALITY OF THE CHRIS HANI DISTRICT.

SUPPLY ARRANGEMENTS BETWEEN THE BIDDER AND HIS/HER SUPPLIER

CERTIFICATE: CONFIRMATION OF SUPPLY ARRANGEMENTS BETWEEN THE BIDDER AND HIS/HER SUPPLIER

NB: This certificate should be completed by the bidder’s supplier(s) and signed by both parties in full and signed in ink by the bidder and his/her supplier. All the required information should be provided. Failure to adhere to these requirements will automatically invalidate the bid.

If more than one supplier is involved, the bidder must submit separate forms, completed by each of his/her suppliers.

Only original or an original certified copy of the certificate will be accepted.

CONTRACT NO. SCMU8-26/27-0029

BID FOR THE SUPPLY AND DELIVERY OF FENCING MATERIAL TO TENTERGATE IRRIGATION SCHEME IN THE ENOCH MGIJIMA LOCAL MUNICIPALITY OF THE CHRIS HANI DISTRICT.

\_\_\_\_\_ has an agreement,
(Name of Bidder Supplier(s))
with \_\_\_\_\_
(Name of Bidder)

to supply of the following items as specified in the bid should they secure a contract in this regard:

Table with 2 columns: Item No., Item Description as per Bid Number. Row 1: 1. As per Bill of Quantities in Pricing Schedule

(N.B. list may be attached)

(To be completed by Bidder’s Supplier)

I hereby confirm that I have familiarised myself with the item(s)\* /description(s) /specification(s) and the conditions of the abovementioned bid.

(\*Delete whichever is not applicable)

\*YES \*NO

I hereby also confirm that \*I am the manufacturer of the item(s) or \*I am a dealer who normally keeps stock of the item(s).

(\*Delete whichever is not applicable)

I also confirm that payment arrangements between the two enterprises have been agreed upon.

(\*Delete whichever is not applicable)

\*YES \*NO

The abovementioned can be confirmed with my company at the following address:

\_\_\_\_\_

Tel number: (\_\_\_\_) \_\_\_\_\_

\_\_\_\_\_

Cell Number: \_\_\_\_\_

\_\_\_\_\_

Fax Number: (\_\_\_\_) \_\_\_\_\_

Address

Contact Person: \_\_\_\_\_

I hereby declare that I am duly authorised in my capacity as \_\_\_\_\_ to issue this certificate, and that the agreement between the parties involved does not constitute fronting.

Signed at \_\_\_\_\_ on this \_\_\_\_\_ of \_\_\_\_\_ 20\_\_\_\_  
(Place) (Day) (Month) (Year)

---



**To be completed by the Bidder's Supplier**

**To be completed by the Bidder**

\_\_\_\_\_  
**Signature (Bidder's Supplier)**

\_\_\_\_\_  
**Signature (Bidder)**

\_\_\_\_\_  
**Name in Print (Bidder's Supplier)**

\_\_\_\_\_  
**Name in Print**

\_\_\_\_\_  
**ID Number Bidder Supplier**

\_\_\_\_\_  
**ID Number Bidder**



agriculture

Department:  
Agriculture  
PROVINCE OF THE EASTERN CAPE

## PROTECTION OF PERSONAL INFORMATION ACT 4 OF 2013

### CLIENT CONSENT

I / We the undersigned: \_\_\_\_\_

Hereby acknowledge that my / our personal and in certain circumstances special personal information is required by the Department of Agriculture in order to process the support which the Department of Agriculture has been mandated to provide and I / we agree to provide such information requested from Department of Agriculture on the express understanding that:

1. This constitutes my consent as required in terms of Section 11 (1) (a) of the POPIA 2013.
2. The Department of Agriculture officials will access my / our personal information which has been furnished to them for the purposes of the support to be provided and matters ancillary thereto.
3. The Department of Agriculture is authorised to release my / our personal information to the South African Revenue Services, other state departments and designated service providers relevant to the support to be provided.
4. Department of Agriculture does not intend to share my / our personal information for financial gain.
5. I / we acknowledge that my / our contact details will be added to the Producer Farmer Register.
6. The Department of Agriculture will store my / our information in accordance with the POPIA prescripts.
7. The Department of Agriculture have implemented proper Data Privacy rules in respect of management of client information as well as proper internet usage rules and cyber security principles in order to minimize the risk of my / our information being exposed to cyber risks. I acknowledge that I have the opportunity to read through the rules and policies as published on the Department of Agriculture's website and understand that it is my own responsibility to protect my own internet and email connections against interceptions and viruses.
8. I / we confirm that:
  - I / we have had the opportunity to review the POPIA policies and rules of the Department of Agriculture.
  - I/ we have had the opportunity to ask questions regarding my / our information, why it is collected and how it is processed and where it is stored and with whom it is shared.
  - I / we consent to the collection, processing and necessary sharing of my / our information by DOA to fulfil its mandate to render agricultural support to me / us.

\_\_\_\_\_  
SIGNATURE

\_\_\_\_\_  
DATE

PROTECTION OF PERSONAL INFORMATION ACT 4 OF 2013 CONSENT – DOA

# The Contract

# **PART C1: AGREEMENT AND CONTRACT DATA**

**EASTERN CAPE PROVINCIAL GOVERNMENT**

**DEPARTMENT OF AGRICULTURE**

**BID FOR THE SUPPLY AND DELIVERY OF FENCING MATERIAL TO TENTERGATE IRRIGATION SCHEME IN THE ENOCH MGJIMA LOCAL MUNICIPALITY OF THE CHRIS HANI DISTRICT.**

**CONTRACT FORM - PURCHASE OF GOODS/WORKS**

**THIS FORM MUST BE FILLED IN DUPLICATE BY BOTH THE SUCCESSFUL BIDDER (PART 1) AND THE PURCHASER (PART 2). BOTH FORMS MUST BE SIGNED IN THE ORIGINAL SO THAT THE SUCCESSFUL BIDDER AND THE PURCHASER WOULD BE IN POSSESSION OF ORIGINALLY SIGNED CONTRACTS FOR THEIR RESPECTIVE RECORDS.**

**PART 1 (TO BE FILLED IN BY THE BIDDER)**

1. I hereby undertake to supply all or any of the goods and/or works described in the attached bidding documents to (name of institution)..... in accordance with the requirements and specifications stipulated in bid number..... at the price/s quoted. My offer/s remain binding upon me and open for acceptance by the purchaser during the validity period indicated and calculated from the closing time of bid.
2. The following documents shall be deemed to form and be read and construed as part of this agreement:
  - (i) Bidding documents, viz
    - Invitation to bid;
    - Proof of tax compliance status;
    - Pricing schedule(s);
    - Technical Specification(s);
    - Preference claim form for Preferential Procurement in terms of the Preferential Procurement Regulations;
    - Bidder’s Disclosure form;
    - Special Conditions of Contract;
  - (ii) General Conditions of Contract; and
  - (iii) Other (specify)
3. I confirm that I have satisfied myself as to the correctness and validity of my bid; that the price(s) and rate(s) quoted cover all the goods and/or works specified in the bidding documents; that the price(s) and rate(s) cover all my obligations and I accept that any mistakes regarding price(s) and rate(s) and calculations will be at my own risk.
4. I accept full responsibility for the proper execution and fulfilment of all obligations and conditions devolving on me under this agreement as the principal liable for the due fulfillment of this contract.
5. I declare that I have no participation in any collusive practices with any bidder or any other person regarding this or any other bid.
6. I confirm that I am duly authorised to sign this contract.

NAME (PRINT) .....

CAPACITY .....

SIGNATURE .....

NAME OF FIRM .....

DATE .....

WITNESSES	
1	.....
2.	.....
DATE:	.....

**CONTRACT FORM - PURCHASE OF GOODS/WORKS**

**PART 2 (TO BE FILLED IN BY THE PURCHASER)**

1. I..... in my capacity as..... accept your bid under reference number .....dated.....for the supply of goods/works indicated hereunder and/or further specified in the annexure(s).
2. An official order indicating delivery instructions is forthcoming.
3. I undertake to make payment for the goods/works delivered in accordance with the terms and conditions of the contract, within 30 (thirty) days after receipt of an invoice accompanied by the delivery note.

<b>ITEM NO.</b>	<b>PRICE (ALL APPLICABLE TAXES INCLUDED)</b>	<b>BRAND</b>	<b>DELIVERY PERIOD</b>	<b>TOTAL PREFERENCE POINTS CLAIMED</b>	<b>POINTS CLAIMED FOR EACH SPECIFIC GOAL</b>

4. I confirm that I am duly authorised to sign this contract.

SIGNED AT .....ON.....

NAME (PRINT) .....

SIGNATURE .....

OFFICIAL STAMP 

WITNESSES  
 1. ....  
 2. ....  
 DATE .....

# **PART C2 – PRICING DATA**

# **C 2.1**

## **Pricing Instructions**

# EASTERN CAPE PROVINCIAL GOVERNMENT

## DEPARTMENT OF AGRICULTURE

### BID FOR THE SUPPLY AND DELIVERY OF FENCING MATERIAL TO TENTERGATE IRRIGATION SCHEME IN THE ENOCH MGIJIMA LOCAL MUNICIPALITY OF THE CHRIS HANI DISTRICT.

#### C2.1 Pricing Instructions

##### 1. GENERAL

The Bill of Quantities forms part of the Contract Documents and must be read and priced in conjunction with all the other documents comprising the Contract Documents, which include the Conditions of Tender, Conditions of Contract, and the Specifications (Particular Specifications).

##### 2. DESCRIPTION OF ITEMS IN THE SCHEDULE

The Bill of Quantities has been drawn up in accordance with the requirements of the equipment needed.

The short descriptions of the items in the Bill of Quantities are for identification purposes only and the measurement and payment clause of the Standardized Specifications and the Particular Specifications, read together with the relevant clauses of the Project Specification, set out what ancillary or associated work and activities are included in the rates for the items specified.

##### 3. QUANTITIES REFLECTED IN THE SCHEDULE

The Works as finally completed in accordance with the Contract shall be measured and paid for as specified in the Bill of Quantities and in accordance with the General and Special Conditions of Contract, the Specifications and Project Specifications. Unless otherwise stated, items are measured net in accordance with the specifications, and no allowance has been made for waste.

The validity of the contract will in no way be affected by differences between the quantities in the Bill of Quantities and the quantities finally certified for payment.

##### 4. PRICING OF THE BILL OF QUANTITIES

The prices and rates to be inserted by the tenderer in the Bill of Quantities shall be the full inclusive prices to be paid by the Employer for the work described under the several items, and shall include full compensation for all costs and expenses that may be required in and for the completion of all the work described and as shown as well as all overheads, profits, incidentals and the cost of all general risks, liabilities and obligations set forth or implied in the documents on which the tender is based.

Each item shall be priced and extended to the "Total" column by the tenderer, with the exception of the items for which only rates are required, or items which already have Prime Cost or Provisional Sums affixed thereto. If the tenderer omits to price any items in the Bill of Quantities, then these items will be considered to have a nil rate or price.

An item against which no price is entered will be considered to be covered by the other prices or rates in the Bills of Quantities. No additional payment or correction will be allowed after closing of tender.

All items for which terminology such as "inclusive" or "not applicable" have been added by the tenderer will be regarded as having a nil rate which shall be valid irrespective of any change in quantities during the execution of the Contract.

The tenderer shall fill in rates for all items where the words "rate only" appears in the "Total" column. "Rate Only" items have been included where:

- (a) an alternative item or material is contemplated.
- (b) variations of specified components in the make-up of a pay item may be expected; and
- (c) no work under the item is foreseen at tender stage but the possibility that such work may be required is not excluded.

For "Rate Only" items no quantities are given in the "Quantity" column but the quoted rate shall apply in the event of work under this item being required. The tenderer shall however note that in terms of the Tender Data the tenderer may be asked to reconsider any such rates which the Employer may regard as unbalanced.

All rates and amounts quoted in the Bill of Quantities shall be in rand and cents and shall include all levies and taxes (other than VAT). VAT will be added in the summary of the Bill of Quantities.

A price or rate is to be entered, in **BLACK INK**, against each item in the Bill of Quantities.

## 5. CORRECTION OF ENTRIES

Incorrect entries shall not be erased or obliterated with correction fluid but must be crossed out neatly. The correct figures must be entered above or adjacent to the deleted entry, and the alteration must be initialed by the tenderer.

## 6. ARITHMETICAL ERRORS

Arithmetical errors found in the Bill of Quantities because of faulty multiplication or addition, will be corrected by the Engineer at the tender evaluation stage, as set out in the Tender Data.

### Important:

- **Gross calculation errors, and omissions in the Bill of Quantities, will render the bid non-responsive.**
- **Gross under and over pricing will also render the bid as non-responsive.**

## 7. UNITS OF MEASUREMENT

The units of measurement described in the Bill of Quantities are metric units for which the standard international abbreviations are used. Non-standard abbreviations that may appear in the Bill of Quantities are as follows:

The units of measurement described in the Bills of Quantities are metric units. Abbreviations used in these Bills of Quantities are as follows:

%	=	percent
Dia	=	diameter
h	=	hour
ha	=	hectare
kg	=	kilogram
kl	=	kiloliter
km	=	kilometer
l	=	liter
m	=	meter
mm	=	millimeter
m <sup>2</sup>	=	square meter
m <sup>3</sup>	=	cubic meter
No.	=	number
Prov sum	=	Provisional sum
PC sum	=	Prime Cost sum
R/only	=	Rate only
sum	=	lump sum
t	=	ton (1000 kg)

# **C 2.2**

## **Bill of Quantities**

PRICING SCHEDULE – FIRM PRICES

(PURCHASES)

NOTE: ONLY FIRM PRICES WILL BE ACCEPTED. NON-FIRM PRICES (INCLUDING PRICES SUBJECT TO RATES OF EXCHANGE VARIATIONS) WILL NOT BE CONSIDERED

NAME OF BIDDER: \_\_\_\_\_

BID FOR THE SUPPLY AND DELIVERY OF FENCING MATERIAL TO TENTERGATE IRRIGATION SCHEME IN THE ENOCH MGIJIMA LOCAL MUNICIPALITY OF THE CHRIS HANI DISTRICT.

SUMMARY OF PRICING SCHEDULE

Item 1: Supply and delivery of Fencing Material to TENTERGATE As per Bill of Quantities	R _____
Sub Total	R _____
15% Value Added Tax	R _____
Total Bid Amount	R _____

Total Bid Amount in Words: \_\_\_\_\_

- Does the offer comply with the specification(s)? \*YES/NO
- If not to specification, indicate deviation(s) .....
- Period required for delivery .....
- Delivery basis .....  
\*Delivery: Firm/not firm

SIGNED: \_\_\_\_\_ NAME OF SIGNATORY (IN CAPITALS): \_\_\_\_\_

SIGNED ON THIS THE \_\_\_\_\_ DAY OF \_\_\_\_\_ OF THE YEAR 20\_\_\_\_\_

ON BEHALF OF \_\_\_\_\_

TELEPHO

NE NUMBER: (\_\_\_\_\_) \_\_\_\_\_ FAX NUMBER: (\_\_\_\_\_) \_\_\_\_\_

I/we choose domicilium citandi et executandi at \_\_\_\_\_  
\_\_\_\_\_ in the Republic of  
South Africa.

## **PAYMENT**

- Part Payment will be made available after the full delivery of all materials for each site as per items as specified in the Bill of Quantities are verified according to specifications of each site.
- Payment will only be affected after the Employer's Representative in the District has verified compliance as correct according to specifications.

The bid price shall include full compensation for supply, delivery, off-loading and staging of the fencing material at the mentioned sites.

**BILL OF QUANTITIES  
DEPARTMENT OF AGRICULTURE**

**BID FOR THE SUPPLY AND DELIVERY OF FENCING MATERIAL TO TENTERGATE  
IRRIGATION SCHEME IN THE ENOCH MGIJIMA LOCAL MUNICIPALITY OF THE CHRIS HANI  
DISTRICT.**

**CONTRACT NO. SCMU8-26/27-0029**

Having examined all the documents, I/we bid as follows:

**ITEM 1: TENTERGATE (18KM)**

ITEM NO	DESCRIPTION	UNIT	QTY	RATE	AMOUNT
1	<b>CORNER/STRAINING POLES</b> 125 – 150mm x 2,1m Treated SANS Timber Poles	No	280		
2	<b>BRACE POLES</b> 120 – 125mm x 1,8m Treated SANS Timber Poles	No	180		
3	<b>Y-STANDARDS</b> Standards steel Y-SECTION 3.0kg/m x 1850mm	No	1500		
4	<b>RIDGEBACK DROPPERS</b> Droppers steel 0.56kg/m x 1200mm	No	2500		
5	<b>WIRE BARBED</b> Lightly Galv mild steel barbed wire, uni-coil 2 x 2,0mm (50kg Rolls)	No	248		
6	<b>WIRE BINDING</b> Lightly Galv mild steel wire 2,0mm (50kg Rolls)	No	18		
7	<b>WIRE ANCHOR</b> Lightly Galv mild steel wire 4,0mm (50kg Rolls)	No	18		
8	<b>HEAVY DUTY FARM GATES: DIAMETER 42 X 2mm</b> 3,6 x 1,2m gates with bolt and chain	No	20		
9	<b>WIRE NETTING</b> Lightly Galvanized netting wire 900 x 90 x 1,8mm (50m roll)	No	18		
10	<b>DELIVERY</b> Delivery to TENTERGATE IRRIGATION SCHEME 60km from Komani, delivery price must include remuneration of local labour for offloading.	Lump Sum	=====	=====	
11	<b>FENCING TRAINING</b>	Lump Sum	=====	=====	R 5 000.00
12	<b>FENCING TOOLS</b> Wire stretcher Bobbejaan big chain	No	5		
	Tension indicator	No	5		
	D shackles 6mm dia (connect tension indicator and stretcher)	No	10		
	Digging Spade all steel	No	15		
	Crow-bar 32 x 1800mm	No	12		
	Fencing pliers 300 mm	No	10		
	Scotch eyed auger bit 19 mm dia Grey color 450mm	No	6		
	Steel T bar auger handles	No	6		
	Steel hand held post driver	No	6		
	Chrome Leather Welding Double Palm Gloves (Pairs)	No	25		
	<b>TOTAL CARRIED TO SUMMARY OF PRICING SCHEDULE (Carry over to Summary)</b>				

# **C 3.1**

## **Specifications**

# PARTICULAR SPECIFICATIONS – FENCING MATERIAL

## PPS STOCK FENCING (SF)

### PPS SF 1 MATERIALS AND DIMENSIONS

#### PPS SF 1.1 APPROVAL OF MATERIALS

The Contractor / Tenderer shall supply in good time to the Engineer, for his approval, samples of the following:

- Samples of all materials to be delivered.

#### PPS SF 1.2 LOCAL CONTENT

The Department of Agriculture supports local production.

#### PPS SF 1.3 CORNER-, STRAINING-, ANCHOR-, GATE POSTS, POSTS, DROPPERS AND BRACES

Corner-, Straining-, Anchor-, Gate Posts and Braces shall be wooden poles and of quality suitable for fencing and to the size indicated on the drawings.

Posts, Braces and droppers shall be treated and bearing the SANS mark. SANS 1288 (Copper-chrome arsenate treated timber) or SANS 05 (Creosote treated timber).

Corner-, Straining-, Anchor- and Gate Posts shall have a length of 2100 mm and a top diameter of between 125 to 150mm.

Timber posts shall have a length of 1800 mm and top diameter of between 75 to 100mm.

Timber droppers shall have a length of 1200 mm and top diameter of between 32 to 50 mm.

Braces shall have a length of minimum 1800 mm and a top diameter of between 100 to 125 mm.

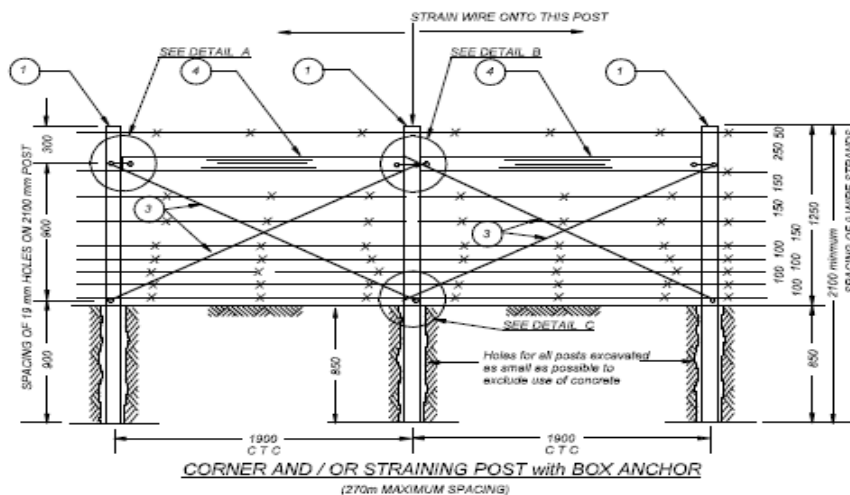

#### PPS SF 1.4 Y- STANDARDS

Standards shall be Y-section iron standards that has a mass of 2,0 kg/m and total length of 1850mm, that is a total mass of 3,7 kg for a 1850 mm length standard. The standards should be provided with notches and holes 50mm apart. Standards shall be according to ISCOR Specifications SPE 261.

#### PPS SF 1.5 DROPPERS

Droppers shall be the Ridgeback iron droppers that has a mass of 0,56 kg/m and total length of 1250 mm. Droppers shall be according to ISCOR Specifications SPE 261

**PPS SF 1.6 WIRES**

(i) Barbed wire

Barbed wire shall comply with the requirements of SANS 675 and shall be of the following type:

Mild-steel-grade lightly galvanized zinc-coated double-strand uni-directional twist wire, each strand 2,00 mm in diameter, for use at any height above ground.

Barbs shall be manufactured from 1,6mm lightly galvanized zinc-coated mild steel wire and shall be spaced at not more than 150 mm.

(ii) Smooth wire

The wire shall be Class A galvanized and comply with the requirements of SANS 675 and shall be of the type specified below:

Anchor wire shall be 4,00 mm diameter lightly galvanized zinc-coated mild steel wire.

Tying wire shall be 2,00 mm diameter mild-steel lightly galvanized zinc-coated wire for tying fencing wire to standards and droppers and 1,6 mm mild-steel lightly galvanized zinc-coated wire for tying netting and mesh wire to the fencing wire.

**PPS SF 1.7 WIRE NETTING**

Wire netting shall be lightly galvanized mild-steel wire with a minimum diameter of 1,8 mm, with 900 x 90 mm hexagonal mesh. Length of each roll must be 50m.

The width shall be as shown on the Bill of Quantities/drawings.

**PPS SF 1.8 MANUFACTURING TOLERANCES FOR WIRES**

The actual diameter of wire supplied shall equal the specified diameter subject to the appropriate tolerance given in SANS 675.

**PPS SF 1.9 GATES**

Gates shall be manufactured to the dimensions and details shown on the Bill of Quantities/Drawings. Gates shall be manufactured of mild steel tubing having continuously welded seams.

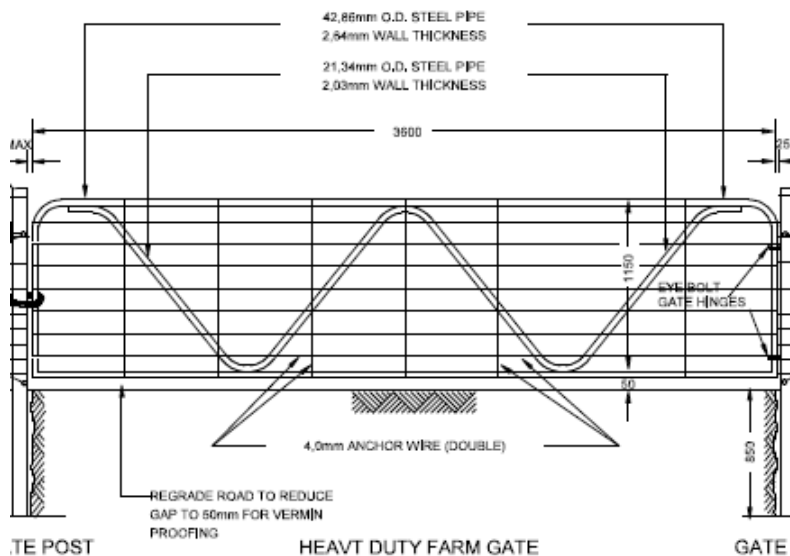

The frame shall be of tubing of bore 42 mm and wall thickness of 2,0 mm in the case of main frame members, and of a bore 22 mm and wall thickness of 2,0 mm in the case of bracing members. The width of each gate shall be as shown on the drawings.

Gates shall be complete in every respect, including hinges, washers, bolts and locking chains attached to the gate.

Gates shall be painted with 2 x coats rust preventative paint and finished with 2 x coats of Silver Shine Aluminum paint.

#### **PPS SF 1.10 TIMBER POSTS FOR WIRE MATS**

Timber posts for holding down wire mats where the fence crosses streams shall comply with the requirements of SANS 457 minimum diameter of 150 mm.

#### **PPS SF 1.11 FENCING TOOLS**

The fencing tools shall be as prescribed in the Bill of Quantities and as per the drawings on the next page.

#### **PPS SF 1.12 FENCING TRAINING**

a The supplier must present a 1 day fencing construction training course for a minimum of 10 delegates to the relevant community as identified by the extension officer of the Department of Agriculture - Chris Hani District.

b The supplier must be a qualified fencing trainer or the supplier's nominee, and the accreditation of the trainee, must be pre-approved by the Engineer.

"The supplier may reserve the right to sub-contract the training, but must obtain the approval of the department, on the nominated sub-contractor."

c The training must take place according to the specifications as per the departmental "Specification of construction materials and methods to be used in Agricultural Infrastructure, Second edition, December 2022", which is downloadable from the Departmental web-site.

d The supplier must supply the trainees with the relevant certificates within two weeks of the delivery of the material.

e Material must be delivered within 31 days of receipt of order.

f The practical training must span a distance of no less than 100m and must include the following:

- 2x Box anchors
- Distance between iron standards
- Distance between droppers
- Straining box
- Number and configuration of strands according to laid down specifications.
- Binding of wire to anchors, iron standards and droppers.

This training span should take place close to the delivery site and should be available to be inspected by the Chief Engineer or representative thereof.

\* Provisional sum: A Provisional sum means that the supplier must supply the department with a quotation for the training as specified, within 7 days after being awarded the contract. The engineer will then scrutinize the quotation, and the accreditation of the trainer, upon which a written approval will be issued, if found satisfactory.

**PPS SF 2 MEASUREMENT AND PAYMENT:**

**Item** **Unit**

**PPS MEASUREMENT AND PAYMENT**

**PPS 1 Poles**

Wooden, Creosote treated, 2,1m x (125-150mm) .....Unit: No

The rates tendered shall cover the cost of supply and it will be measured in numbers.

**PPS 2 Poles**

Wooden, Creosote treated, 1.8m x (100-125mm) .....Unit: No

The rates tendered shall cover the cost of supply and it will be measured in numbers.

**PPS 3 Y-Standards**

3.0kg/m x 1.85m .....Unit: No

The rates tendered shall cover the cost of supply and it will be measured in numbers.

**PPS 4 Ridgeback Droppers**

0.56kg/m x 1200mm ..... Unit: No

The rates tendered shall cover the cost of supply and it will be measured in numbers.

**PPS 5 Wire barbed.**

2 x 2mm, lightly galvanized .....Unit: No

The rates tendered shall cover the cost of supply and it will be measured in numbers.

**PPS 6 Wire binding**

2,5mm mild steel, lightly galvanized..... Unit: No

The rates tendered shall cover the cost of supply and it will be measured in numbers.

**PPS 7 Wire Anchor**

4mm mild steel, lightly galvanized..... Unit: No

The rates tendered shall cover the cost of supply and it will be measured in numbers.

**PPS 8 Gates**

Farm gate heavy duty ..... Unit: No

The rates tendered shall cover the cost of supply and it will be measured in numbers.

**PPS 9 Wire netting**

Lightly galvanised 1200 x 90mm ..... Unit: No

The rates tendered shall cover the cost of supply and it will be measured in numbers.

**PPS 10 Fencing Material Delivery**

Fencing Material Delivery..... Unit: Lump Sum

The unit of measurement for the Fencing material delivery shall be the Lump Sum of items delivered as per Bill of Quantities.

**PPS 11 Fencing Training**

Training ..... Unit: Prov. Sum

Fencing training will be paid under provisional sum.

**PPS 12 Fencing Tools**

Fencing Tools .....Unit: No

The rates tendered shall cover the cost of supply and it will be measured in numbers.

**The tendered rates shall include full compensation for supply fencing materials, delivery fencing materials to the site, offloading and proper staging the fencing materials for ease of counting and checking at the specific site.**

FENCING TOOLS

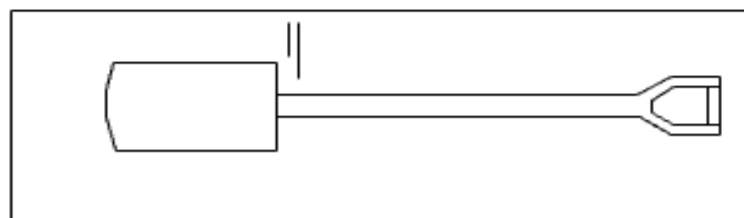
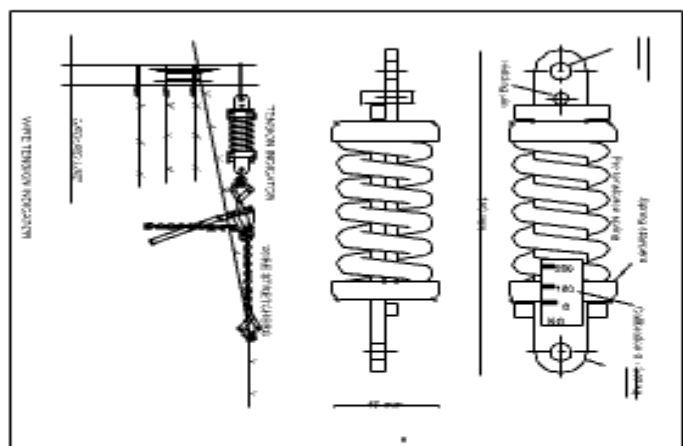
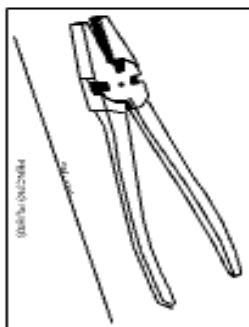
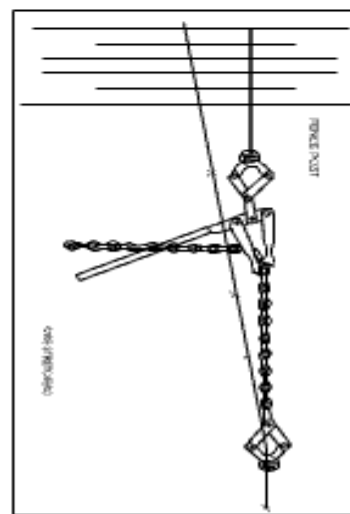
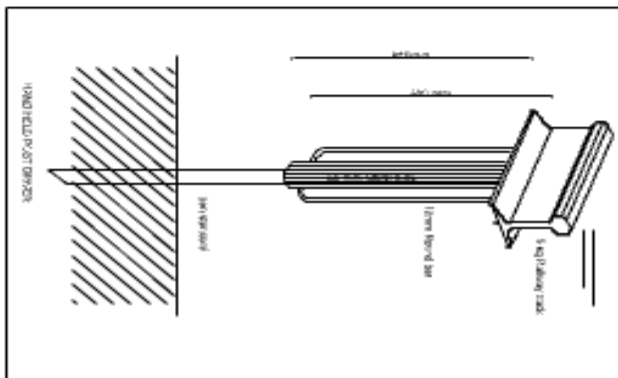
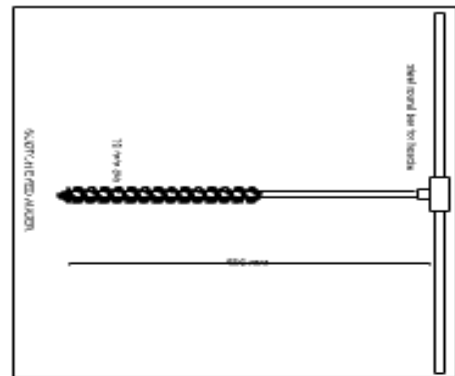
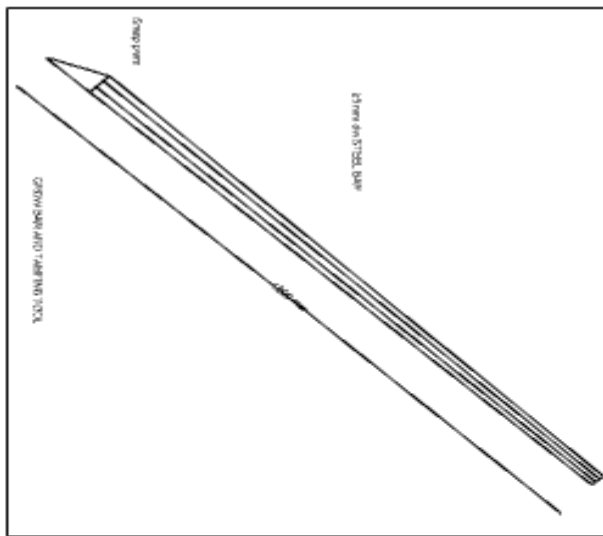

## **C 4.1**

# **CONDITIONS OF CONTRACT**

## EASTERN CAPE PROVINCIAL GOVERNMENT

### DEPARTMENT OF AGRICULTURE

#### BID FOR THE SUPPLY AND DELIVERY OF FENCING MATERIAL TO TENTERGATE IRRIGATION SCHEME IN THE ENOCH MGIJIMA LOCAL MUNICIPALITY OF THE CHRIS HANI DISTRICT.

The contract shall be governed by the "National Treasury General Conditions of Contract (July 2010). These General Conditions are available for inspection at the offices of the Departmental Head Office at Bhisho, Deputy Director: Supply Chain Management (SCM).

#### B. SPECIAL CONDITIONS OF CONTRACT

The Special Conditions of Contract form an integral part of the Contract. The Special Conditions of Contract shall amplify, modify or supersede, as the case may be, the General Conditions of Contract to the extent specified below, and shall take precedence and shall govern. **The following Special Conditions of Contract will apply.**

SECTION	SUBJECT
4. Standards	4.1 The material standards shall confirm to the Scope of Works (Project Particular Specifications)
7. Performance Security	7.1 No Performance Security is Required
9. Packing	9.2 <i>All packing material shall clearly indicate the contents of the materials inside the packing.</i>
10. Delivery of works/services	10.1 <i>The Bidder will deliver the Services as requested to the Department as specified in the Scope of works (Project Particular Specifications) at the identified sites. A detail delivery note that include the full list of all the materials that are delivered shall be supplied by the service provider.</i> 10.2 <i>The Bidder will make delivery arrangements with the project leader for inspection of material to confirm compliance and verify the material and counting material.</i> 10.3 <i>The material will be sorted to the different items and stacked for easy counting.</i> 10.4 <i>The Bidder will complete the full project within the time frame stated after order received. (Maximum of 31 Days allowed to complete)</i>
11. Insurance	11.1 <i>Insurance shall cover all the materials and goods for the full period until such time as that the delivery note has been properly signed off by the Engineer's Representative. <b>NOT APPLICABLE IN THIS CONTRACT</b></i>
12. Transportation	12.1 <i>Delivery of materials to the different sites shall include full costs for the all-inclusive delivery of the materials and goods, the off-loading thereof and proper stacking for counting purposes.</i>
13. Incidental Services	13.1 <i>The Bidder is required to provide all services for the off-loading and proper packing/stacking of the materials at the sites.</i>
14. Spare parts	14.1 No spare parts are required from the supplier.
15. Warranty	15.1 The warranty on all electrical equipment and pump equipment shall be for a minimum period of twelve months and shall commence from the date that the delivery note has been signed. 15.2 The supplier shall repair or replace all goods under warranty within a period of four (4) weeks after receiving such notice from the purchaser.

16. Payment	<p>16.1 Part Payment will be made available after portions of the materials delivered to site, inspected and approved by the Engineer's Representative in line with the Bill of Quantities and verified according to specifications.</p> <p>16.2 Payment will be made within a period of 30 days after the receipt of the invoice.</p>
17. Prices	17.1 Prices charged by the supplier for services performed under the contract shall not vary from the prices quoted by the supplier in his bid.
21. Delays in the Bidders performance	<p>21.1 Delivery of the services and performance of services shall be made by the Bidder in accordance with the time schedule prescribed in the Bid Rules and Special Conditions of Contract (SCC) clause 10.4 in the contract.</p> <p>21.2 If at any time during performance of the contract, the Bidder or its supplier should encounter conditions impeding timely delivery of the performance of services, the Bidder shall promptly notify the Department in writing of the fact of the delay, its likely duration and its cause(s). As soon as practicable after receipt of the Bidder's notice, the Department shall evaluate the situation and may at his discretion extend the Bidder's time for performance, with or without the imposition of penalties, in which case the extension shall be ratified by the parties by amendment of contract.</p>
22. Termination for default.	<p>23.1 The Department, without prejudice to any other remedy for breach of contract, by written notice of default sent to the supplier, may terminate this contract in whole or in part:</p> <p>(a) if the bidder/supplier fails to deliver any or all of the services within the period(s) specified in the contract, or within any extension thereof granted by the Department.</p> <p>(b) if the bidder/supplier fails to perform any other obligation(s) under the contract; or</p> <p>(c) if the bidder/supplier, in the judgment of the Department, has engaged in corrupt or fraudulent practices in competing for or in executing the contract.</p>
23. Force Majeure	25.2 If a force majeure situation arises, the bidder/supplier shall promptly notify the Department in writing of such condition and the cause thereof. Unless otherwise directed by the Department in writing, the bidder/supplier shall continue to perform its obligations under the contract as far as is reasonably practical and shall seek all reasonable alternative means for performance not prevented by the force majeure event.
24. Termination for insolvency.	26.1 The Department may at any time terminate the contract by giving written notice to the bidder/supplier if the bidder/supplier becomes bankrupt or otherwise insolvent. In this event, termination will be without compensation to the bidder/supplier, provided that such termination will not prejudice or affect any right of action or remedy which has accrued or will accrue thereafter to the Department.
25. Settlement of Disputes	<p>27.1 The parties may at any time, without prejudice to any other proceedings, agree to settle any claim or any dispute amicably with the help of an impartial third party. Amicable settlement may include any settlement technique as agreed to by the parties.</p> <p>27.2 Amicable settlement shall become final and binding on the parties only to the extent that it is correctly recorded as being agreed to by the parties.</p>
26. Applicable law	30.1 The contract shall be interpreted in accordance with South African Laws.
GENERAL ITEMS	<p>1. The bid forms are drawn up so that certain essential information is to be furnished in a specific manner. Any additional particulars shall be furnished in a separate questionnaire or in a separate annexure.</p> <p>2. The Preference Claim and other relevant forms, attached, shall be</p>

	<p>completed, signed and submitted with the bid. Documentary proof as substantiation of preferences claimed and to the satisfaction of the Department, should be handed in with the bid.</p> <ol style="list-style-type: none"> <li>3. Where items are specified in detail, the specifications form an integral part of the bid document and bidders shall indicate in the space provided whether the items offered are to specification or not. Failure to complete, will automatically disqualify the Bid for any further consideration.</li> <li>4. In respect of the paragraphs where the items offered are strictly to specification, bidders shall insert the words "as specified".</li> <li>5. In cases where the items are not to specification, the deviations from the specifications shall be indicated.</li> <li>6. The bid prices shall be given in the units shown.</li> <li>7. All prices shall be quoted in South African currency.</li> <li>8. Delivery basis:       <ol style="list-style-type: none"> <li>(a) Supplies which are held in stock or are in transit or on order from South African manufacturers at the date of bidding, shall be offered on a basis of delivery into consignee's store or on his site within the free delivery area of the bidder's centre, or carriage paid consignee's station if the goods are required elsewhere.</li> <li>(b) Notwithstanding the provisions of paragraph 8(a), bid prices for supplies in respect of which installation/erection/assembly is a requirement, shall include ALL costs on a basis of delivered on site as specified.</li> </ol> </li> <li>9. No bids transmitted by telegram, telex, facsimile or similar apparatus shall be considered.</li> <li>10. Failure on the part of the bidder to sign this bid form and thus to acknowledge and accept the conditions in writing or to complete the attached forms, questionnaires and specifications in all respects, may invalidate the BID.</li> <li>11. Bids should be submitted on the official forms and should not be qualified by the bidder's own conditions of bidding. Failure to comply with these requirements or to renounce specifically the bidder's own conditions of bidding, when called upon to do so, may invalidate the bid.</li> <li>12. The bid forms should not be retyped or redrafted but photocopies may be prepared and used. Additional offers may be made for any item but only on a photocopy of the page in question or on other forms obtainable from the relevant Institution. Additional offers made in any other manner may be disregarded.</li> <li>13. Black ink shall be used to fill in bids. No unauthorized alteration shall be made to the document. Mistakes made by the Bidders in the completion of the pricing schedule, forms, etc. shall not be erased nor erasing fluid used. A line shall be drawn through the incorrect entry and the correct entry shall be written above and the correction initialed by the Bidders. Bid may also be rejected if they show any additional items not originally included in the Bid documents, conditional or incomplete offers, irregularities of any kind in either the Bid form or the priced schedule, or if the rates and amounts quoted in the schedule are obviously unbalanced and the Bidders, after having been called upon to adjust same in a reasonable manner, fails to do so within a period of seven days of having received notification to that effect.</li> <li>14. The Bidder shall satisfy himself that the documents received are</li> </ol>
--	---

	<p>correct, complete and sufficient to be the basis of a <i>bona fide</i> Bid. Bidders shall check the numbers of the pages and satisfy themselves that none are missing or duplicated. No liability shall be accepted in regard to claims arising from the fact that pages are missing or duplicated. Should a Bidder not accept that the documents issued can form the basis of a <i>bona fide</i> Bid the SCM Unit shall be requested to correct the discrepancy, ambiguity, missing or illegible information prior to the submission of Bid. The submission of a <i>bona fide</i> Bid shall absolve the Employer from any liability whatsoever for any error in a Bid due to the foregoing.</p> <p>15. The relevant consultant/contractor agrees that should any dispute arise from the contract, the matter shall be submitted to the relevant Bid Adjudication Committee for a ruling and such ruling shall be final.</p> <p>16. In the event that the bidder is not the actual manufacturer and will be sourcing the product(s) from another company, an unconditional letter (or certificate: confirmation of supply arrangements between the bidder and his/her supplier) from the company(ies)/supplier(s) confirming supply arrangement(s) in this regard, has to accompany the bid at the closing date and time of bid. The said company/supplier must confirm that it has familiarized itself with the item description, specifications and bid conditions and if the bid consist of more than one item, it should be clearly indicated in respect of which item(s) the supportive letter has been issued. It must be indicated in the above-mentioned letter that all financial arrangements with regard to payment between the prospective bidder and manufacturer/company/supplier issuing such a letter has been finalized and terms and conditions mutually agreed upon. Non-compliance with the above-mentioned special conditions would automatically invalidate the bid for such products offered.</p> <p>17. The Bid must be signed by one duly authorized to do so. In the case of a Bid being submitted on behalf of a Company, Close Corporation, Partnership or Joint Venture, such Bid shall be accompanied by a certified copy of a resolution of the Board of Directors of such Company, Close Corporation or other suitable authority in the case of a Partnership or Joint Venture, in terms of which the nominee is authorised to sign on behalf of the business entity.</p> <p>The joint venture documentation is also to clearly state that all its parties will remain severally and jointly bound for the duration of the defects liability period, as well as setting out how matters will be dealt with that may arise as latent defects once the joint venture has dissolved.</p> <p>If due to any unforeseen reasons the joint venture dissolves during the defects liability period, the agreement must clearly state how the liability will be dealt with in terms of honoring all the responsibilities it may still have with regards to the due performance of all contractual issues that could arise.</p> <p>18. These conditions form part of the bid/ price quotation and failure to comply therewith may invalidate a bid/ price quotation.</p>
--	--