

	<b>Technical Specification</b>	<b>Technology</b>
---	--------------------------------	-------------------

**Title:** Duvha PS Diesel Generator Replacement – *Employer’s* Requirements Scope of Works Report

**Unique Identifier:** 382-ECM-AABZ18-PN0017-5

**Alternative Reference Number:** N/A

**Area of Applicability:** Engineering



**Documentation Type:** Work Information

**Revision:** 4

**Total Pages:** 36

**Next Review Date:** N/A

**Disclosure Classification:** **CONTROLLED DISCLOSURE**

Compiled by	Functional Responsibility	Authorised by
		
<b>L Mabitla</b> <b>System Engineer</b> <b>Electrical Engineering</b>	<b>A Nqayane</b> <b>Electrical Engineering</b> <b>Manager</b>	<b>M Mamoleka</b> <b>Engineering Manager</b>
Date: 01/04/2026	Date: 2026/04/02	Date: 2026-04-02

## CONTENTS

	Page
<b>1. INTRODUCTION .....</b>	<b>5</b>
<b>2. SUPPORTING CLAUSES.....</b>	<b>5</b>
2.1 SCOPE .....	5
2.1.1 Purpose .....	5
2.1.2 Applicability.....	5
2.2 NORMATIVE/INFORMATIVE REFERENCES.....	5
2.2.1 Normative .....	5
2.2.2 Informative.....	5
2.3 DEFINITIONS.....	5
2.3.1 Disclosure Classification .....	6
2.4 ABBREVIATIONS.....	6
2.5 ROLES AND RESPONSIBILITIES.....	7
2.6 PROCESS FOR MONITORING.....	7
2.7 RELATED/SUPPORTING DOCUMENTS.....	7
<b>3. SYSTEM DESCRIPTION (SEE APPENDIX A, B AND C) .....</b>	<b>7</b>
<b>4. OPERATING AND CONTROL PHILOSOPHY .....</b>	<b>8</b>
4.1 TYPICAL DIESEL GENERATOR CONTROL AND INTERLOCKING .....	9
<b>5. DESRIPTION OF WORKS .....</b>	<b>11</b>
5.1 DIESEL GENERATOR GENERAL LAYOUT AND COMPONENTS.....	12
5.2 INTERFACE REQUIREMENTS .....	13
5.2.1 Diesel Generator Control panel and Controllers requirements .....	13
5.2.1.1 Diesel Generator Control panel requirements .....	13
5.2.1.2 Controllers requirements .....	14
5.2.2 Special design requirements .....	14
5.2.3 Power Station Control System interfaces requirements (see figure 2) .....	15
5.2.4 Alarm signals and indications requirements.....	15
5.2.5 Starting system requirements.....	17
5.2.6 Fire protection requirements .....	19
5.2.7 Diesel Generator room ventilation requirements.....	19
5.2.8 Cooling water supply requirements .....	20
5.2.9 Fuel oil system requirements .....	22
5.2.10 Colour Coding requirements .....	22
5.2.11 C&I Requirements .....	23
5.2.11.1 Applicable C&I standards.....	24
5.2.12 Civil requirements.....	24
5.2.13 Reliability and Availability requirements .....	26
5.2.14 HAZLOC requirements.....	26
5.2.15 Spares requirements .....	26
5.2.15.1 Operational spares requirements.....	27
5.2.15.2 Overhaul spares requirements .....	27
5.2.15.3 Strategic spares requirements .....	27
5.3 SYSTEM INTEGRATION REQUIREMENT .....	27
5.3.1 Quality requirements .....	27
5.3.2 Drawing Requirements.....	28
5.3.3 Configuration Management and Document Management .....	28
5.3.3.1 Document Submission requirements .....	28
5.3.3.2 Transmittal requirements .....	28
5.3.3.3 Plant Codification requirements .....	29

### CONTROLLED DISCLOSURE

When downloaded from the EDMS, this document is uncontrolled and the responsibility rests with the user to ensure it is in line with the authorised version on the system.

---

5.3.3.4 Plant Labelling requirements.....	29
5.3.3.5 Email Subject requirements .....	29
5.3.3.6 Documentation requirements .....	29
5.3.3.7 Documentation .....	30
5.3.3.8 General Requirement.....	30
5.3.3.9 Engineering Change Management .....	31
5.4 RISK AND ISSUE REGISTER .....	31
5.5 DRAWINGS ISSUED BY THE EMPLOYER .....	31
<b>6. AUTHORISATION .....</b>	<b>32</b>
<b>7. REVISIONS .....</b>	<b>32</b>
<b>8. DEVELOPMENT TEAM .....</b>	<b>32</b>
<b>9. ACKNOWLEDGEMENTS .....</b>	<b>32</b>
<b>10. APPENDIX A: TYPICAL EXISTING SUBSTATION LAYOUT .....</b>	<b>33</b>
<b>11. APPENDIX B: GENERAL ARRANGMENT FOR EXISTING DIESEL GENERATOR CONTROL PANEL .....</b>	<b>34</b>
<b>12. APPENDIX C: UNIT 380V ESSENTIAL SUPPLY SYSTEM SINGLE LINE DIAGRAM .....</b>	<b>35</b>
<b>13. APPENDIX D: REFERENCE FOR LIST OF APPROVED CONTROLLERS FOR ESKOM .....</b>	<b>36</b>

**CONTROLLED DISCLOSURE**

When downloaded from the EDMS, this document is uncontrolled and the responsibility rests with the user to ensure it is in line with the authorised version on the system.

## EXECUTIVE SUMMARY

The Diesel Generators on several units are not available due to several damages and obsolescence of replacement components.

The Station requires an urgent replacement of one diesel generator per unit on five (5) units. This means a total of five diesel generator sets including the associated diesel generator control panel to ensure reliability of the unit back up system and have at least one diesel generator per unit.

The detail design engineering for this project shall be done as detailed in the diesel generator standard (240-62772907) and only the technical requirements and interfaces required for the replacement of the 5 diesel generator sets shall be define as part of this document. The project boundaries for each technical discipline were as follows:

- Electrical: The electrical project boundary was within the diesel generator room (diesel generators (engines + alternators), including associated auxiliaries (diesel generator control panel, starting system, protection system, circuit breakers), and power cabling up to the 380V Diesel Generator Board.
- Control and Instrumentation (C&I): C&I project boundary was from the existing controllers including junction boxes, instrumentation, control cabling, and interface from EOD to unit control room for monitoring alarms and status of diesel generators.
- Low Pressure Services (LPS): The LPS project boundary was within the diesel generator room (diesel generators (engines + alternators), including associated auxiliaries (bulk fuel oil supply system, cooling system, HVAC and fire protection system). The above systems will be assessed and replaced where necessary.
- Civils and Structures: Civils and Structures project boundary was within the diesel generator room and outside the diesel generator room where the water cooling towers and diesel storage tanks are installed. Civil will conduct load verification for the new equipment.

### Battery limits and scope inclusions and exclusions

The project battery limits were defined as per the four (4) bullet points above. The project include the replacement of 5 diesel generator sets, including replacing their respective diesel generator control panels. The replacement of the stated diesel generators and associated diesel generator control panels will take into consideration the existing infrastructure i.e. room layout, pipe layouts, configuration for the existing and future Power Station Control System, interfaces to existing diesel storage tank, the water cooling system, the existing air starting system, fire protection system ventilation system and cabling. The scope of work exclude the diesel storage tank, the water cooling tower, two water duty pumps, the existing air starting system (1x compressor and 2 x air receivers), the ventilation system and the fire protection system since these auxiliary systems will be retained. For the starting system, the battery starting system will be considered as optional.

The existing reticulation will be retained; hence the *Contractor* shall perform the RAM (Reliability, Availability and Maintainability) studies of the equipment to be replaced in the Works, in accordance with the *Employer's* System RAM Analysis Guideline [4].

### CONTROLLED DISCLOSURE

## 1. INTRODUCTION

The Diesel Generators on several units are not available due to several damages and obsolescence of replacement components.

The Station requires an urgent replacement of one diesel generator per unit on five (5) units. This means a total of five diesel generator sets including the associated diesel generator control panel to ensure reliability of the unit back up system and have at least one diesel generator per unit.

It is therefore essential to replace the said diesel generators sets with an equivalent (1MW) diesel generators. The replacement will ensure 100% redundancy for essential supplies in the event of the mains supply failure, and also improve the plant long term availability and reliability status.

## 2. SUPPORTING CLAUSES

### 2.1 SCOPE

The project requires the replacement of 5 (five) diesel generators sets including the associated diesel generator control panel to bring back the full unit backup system and thus ensuring at least one diesel generator per unit at Duvha Power Station.

#### 2.1.1 Purpose

The purpose of this document is to define the technical requirements and interfaces required for the replacement of 5 (five) diesel generators with an equivalent (1MW) diesel generators. The detail design engineering shall be done as detailed in the Specification (240-62772907) and Technical Schedule A, as well as all standards and specifications referenced.

#### 2.1.2 Applicability

This document shall apply to Duvha Power Station, Group Technology Engineering and the Contractor.

### 2.2 NORMATIVE/INFORMATIVE REFERENCES

Parties using this document shall apply the most recent edition of the documents listed in the following paragraphs.

#### 2.2.1 Normative

- [1] Electrical Plant-Unit 380V standby supplies – system description and operations: E1008
- [2] Specification for Diesel Generator systems: 240-62772907, rev 2
- [3] Eskom Heating Ventilation and Air Conditioning (HVAC) Design Guideline: 240-70164623

#### 2.2.2 Informative

- [4] 240-53113685: Design Review Procedure (<https://hyperwave.eskom.co.za/240-53113685>)
- [5] 240-52844017: Eskom System Reliability, Availability and Maintainability Analysis Guideline
- [6] 240-56536505: Hazardous Locations Standard

### 2.3 DEFINITIONS

Definition	Description
Set	Engine + Alternator

### CONTROLLED DISCLOSURE

When downloaded from the EDMS, this document is uncontrolled and the responsibility rests with the user to ensure it is in line with the authorised version on the system.

Definition	Description
Auxiliary systems	Generator panel, starting system, cooling system, fuel supply system, etc.
Diesel Generator Panel	Control + power circuitry including generator breakers

### 2.3.1 Disclosure Classification

**Controlled Disclosure:** Controlled Disclosure to external parties (either enforced by law, or discretionary).

### 2.4 ABBREVIATIONS

Abbreviation	Description
AKZ	Anlagenkennzeichnungs system
C & I	Control and Instrumentation
CoE	Centre of Excellence
DCS	Distributed Control System
DC	Direct current
EDMS	Electronic Document Management System
EOD	Electrical Operated Desk
FAT	Factory Acceptance Tests
GA	General Arrangement
HVAC	Heating, Ventilation and Air Conditioning
ITP	Inspection Test Plan
LOSS	Limits of Supply and Service
MTU	Motoren and Turbine Units
MW	Megawatt
OEM	Original Equipment Manufacturer
P&ID	Piping and Instrument Diagram
PLC	Programmable Logic Controller
QCP	Quality Control Plan
QC	Quality Control
SAS	Substation Automation System
SANS	South African National Standard
SAT	Site Acceptance Tests
SCADA	Supervisory Control and Data Acquisition
VDSS	Vendor Document Submittal Schedule

### CONTROLLED DISCLOSURE

When downloaded from the EDMS, this document is uncontrolled and the responsibility rests with the user to ensure it is in line with the authorised version on the system.

## 2.5 ROLES AND RESPONSIBILITIES

### **Contractor Responsibilities: (see LOSS Diagram)**

- Design, manufacture, construct, factory acceptance testing, transporting, offloading, installation and commissioning of the four Diesel Generators including the associated Diesel Generator Control Panels.
- Decommission and removal of damaged Diesel Generators and preserved for spare items.
- Ensure the new Diesel Generators interface to existing auxiliaries (cooling system, starting system, fuel oil system, ventilation system, fire protection system, SCADA system) including power cables and 380V Diesel Generator Board.

**Note:** Contractor provides full design package including all drawings and data package which becomes the property of the *Employer*.

### **Employer responsibilities: (see LOSS Diagram)**

- Provide the operating and control philosophy to be updated by the Contractor.
- Provide the electrical point of supply and lifting facilities during commissioning.

## 2.6 PROCESS FOR MONITORING

The Engineering Change Management Procedure (240-53114002) will be the document used for monitoring of the project and relevant PCMs will also be used. Changes to the project will be captured through the Project Engineering Change Procedure (240-53114026). All the design work will be reviewed according to the Design Review Procedure (240-53113685). Additional Verification and Validation process will be determined during the project as and when required. A project implementation schedule will also be used to monitor progress within the project.

## 2.7 RELATED/SUPPORTING DOCUMENTS

E1008: Electrical Plant-Unit 380V standby supplies – system description and operations.

## 3. SYSTEM DESCRIPTION (SEE APPENDIX A, B AND C)

The current diesel driven generator sets diesel engines start with compressed air through the cylinders from a mini compressor plant which is housed within the diesel driven generator house. A starting air distributor, mounted on the designed coupling end of the engine and driven by a camshaft, directs the already available air to the cylinders of the left bank in firing order. The left bank cylinder heads are therefore each equipped with a starting valve.

If the air pressure in the air vessels drops to about 33 bars, the electrically driven compressor is switched on by a pressure control switch and switched off again at 40 bars.

In case of a compressor failure, an alarm signal is activated by another pressure control switch if the air pressure falls to about 28 bars.

The diesel engine is cooled by two separate cooling systems, the engine cooling system and the raw water system.

The coolant is preheated to about 50° Celsius by a preheating unit installed at the lowest point of the cooling system. This facilitates starting, prevents residue from fuel and engine oil in the combustion spaces and also cold starting wear. The preheating unit is switched on and off at 45°C and at 55 °C through a temperature controller installed into the coolant collecting line.

### **CONTROLLED DISCLOSURE**

With the engine running, the coolant is circulated by the engine coolant pump. The latter is mounted to the engine and driven by a camshaft through gears. The coolant pump circulates the coolant to the turbocharger and through the engine oil heat exchanger and preheating unit into the cooling spaces of the engine.

The coolant encircles the cylinder liners from the bottom to the top. Drilling connect the cooling spaces of the crankcase with those of the cooling spaces of the engine. In the cylinder-head the coolant cools the bottom, valve guides, and pre-chamber; in the turbocharger the inlet and outlet housing.

The coolant is discharged from the individual cylinder heads and the turbocharger, collects in the collecting line and flows to the thermostat. The thermostat directs the coolant either directly, or via the cooler, to the coolant pump.

A coolant expansion tank is located at the uppermost point of the cooling system, and connected with it through compensating and vents lines. For filling and emptying of the cooling system a drain cock is fitted at the lowest point of the system.

For checking the coolant level, one sight glass on the coolant expansion tank is provided and also for temperature, different temperature controllers are provided.

For potable water system, each back up diesel generator house is installed with water cooling towers next to it which supplies cooling water to the plant. Potable water is used to cool the engine coolant and the charge air. The potable water is circulated through the intercooler at a pressure of minimum 1, 5 bar and a maximum 2, 5 bar to cool the charge air.

The water discharged from the intercooler is directed to the cooler. The cooler is connected into the raw water system not on the engine, and cools the engine coolant to operating temperature.

For fuel system, each back up diesel generator house is installed with fuel tank next to it, which supplies the fuel to the diesel generators. A fuel pre-filter is installed into the suction line of the delivery pump to filter out the largest impurities for the protection of the fuel delivery pump.

The fuel delivery pumps are mounted on the fuel injection pumps and driven by the latter's camshafts. They draw the fuel from the fuel tank through a fuel pre-filter installed in the suction line and deliver it to the fuel injection pumps via the switchable fuel dual filters. The non-return valves allow replacement of the filter inserts while the engine is running.

According to the demanded engine power a metered amount of fuel is delivered by the injection pumps into the cylinder spaces through the injection nozzles. An overflow channel in the fuel injection pumps allows return flow of excess fuel into the fuel tank.

The diesel engine control system consists of a programmable logic controller that supervises and controls all engine functions and alarms. A manual start key switch on the local control panel provides the backup for the diesel engine system if the diesel engine's own control panel system fails. See Appendix A for the existing typical substation layout.

The General Arrangement for the existing Diesel Generator Control Panel is as indicated in Appendix B. The Diesel Generator Control Panel consist of five (5) panels namely: a) Unit A alternator incomer, b) Unit A engine control alarm circuits and metering, c) Common synchronising and unit auxiliaries' supply, d) Unit B alternator incomer, and e) Unit B engine control alarm circuits and metering.

#### 4. OPERATING AND CONTROL PHILOSOPHY

The operation of the newly installed Diesel Generators shall be completely integrated into the operation of the existing Diesel Generator Systems. This will include the following:

- The current operating philosophy for both the Electrical Plant-Unit 380V standby supplies [1] operating instructions shall be utilised and updated where necessary.

#### CONTROLLED DISCLOSURE

- Any design for these units shall consider including compatibility with the new DCS or SAS (as per the configuration defined in figure 2) to ensure future compatibility.

Refer to Appendix B for the Single Line Diagram of the existing Unit 380V essential supply system and for detailed Unit 380V essential supply system description and operation, see document number (E1008): Electrical Plant-Unit 380V standby supplies – system description and operations.

#### 4.1 TYPICAL DIESEL GENERATOR CONTROL AND INTERLOCKING

The Diesel Generator control and interlocking shall be realized by controllers as per the list of approved controllers by the *Employer*: 240-56227589, List of approved Electronic Devices to be used on Eskom Power Stations Standard, also see Appendix D) or similar devices that need to be type tested by the Employer before they can be used. The programming equipment, programming-software and the Control and Interlocking software shall become the property of the *Employer* after completion of the Works.

##### Operating Modes (New DCS/SAS):

The Diesel Generator shall have 4 operating modes which are:

- Off (Isolated)
- Remote
- Local
- Test

In Off Mode the Diesel Generator shall:

- Not react to any Local or remote starting signals,
- The fuel to the Diesel Generator shall be cut via the fuel cut Solenoid,
- An Off mode indication shall be displayed on the local Annunciater panel and an Off Mode Status feedback signal sent to EOD / Unit control room.

In the Remote Mode the Diesel Generator shall:

- For Diesel Generator Set A or Set B Indicate Remote mode to the EOD / unit control room and on the Annunciater.
- Start and run up to rated frequency and voltage when a remote start signal is received and the Generator breaker is open.
- Close the Generator Breaker if the Generator is at rated frequency and Voltage, there is no voltage on the associated Diesel Generator board, all the downstream breakers on the associated Diesel Generator board and the Standby Generator Breaker are open (see document number (E1008): Electrical Plant-Unit 380V standby supplies – system description and operations).
- Not be able to be started from local,
- After five failed start attempts indicate Start Failure on the local annunciater and EOD / unit control room. Send a Start signal to the Standby Diesel Generator.

For the Standby Diesel Generator Set A or Set B:

- Indicate Remote mode to the EOD / unit control room and on the Annunciater
- Start and run up to rated frequency and voltage when a start signal is received from either Diesel Generator Set A or Set B and the Generator breaker is open,
- Close the Generator Breaker A or B onto Diesel Generator board depending from which Generator Set A or Set B, the start signal has been received. If the Generator is at rated frequency and Voltage, there is no voltage on the associated Diesel Generator board and all the other associated breakers and the Generator breaker A or B are open (see document number (E1008): Electrical Plant-Unit 380V standby supplies – system description and operations).

#### CONTROLLED DISCLOSURE

- Not be able to be started from local,
- After three failed start attempts indicate Start Failure on the local annunciater and EOD / unit control room.

In Local mode for Diesel Generators Set A and Set B:

- Indicate Local mode to the EOD / unit control room and on the Annunciater
- Be able to be started locally and the Generator breaker closed if there is no voltage on the associated Diesel Generator board and all the other associated breakers and Standby Diesel Generator breaker are open. In the case of the Standby Diesel Generator all the other breakers shall be open before the associated Standby Diesel Generator Breaker can be closed (see document number (E1008): Electrical Plant-Unit 380V standby supplies – system description and operations).

Diesel Generator Testing:

- It shall be possible to test any of the two (2) Diesel Generators in both the Remote and Local mode.
- During testing the relevant Diesel Generator shall be synchronised to the Diesel Generator Board, which will be connected to either the unit boards or the station boards via associated breakers, and loaded to a required load. It shall only be possible to test one diesel generator at a time via the 380V Diesel Generator board.

**Interlocking:**

- It shall not be possible to have two Generators synchronised to the same Diesel Generator board at the same time,
- It shall not be possible to close a Generator breaker without synchronizing when the Diesel Generator board is alive and not in Test mode.
- It shall not be possible to start the Generator and close the Generator breaker if a trip is active.
- It shall not be possible to close the Generator breaker if the Generator is not at rated frequency and voltage.

**NB:** The above information is preliminary. Realization of the Diesel Generator Control system and Interlocking functionality shall have to be agreed during the scheduled Design Review and upon updating and finalisation of the Duvha Diesel Generator Operating, Control and Protection philosophy.

**CONTROLLED DISCLOSURE**

## 5. DESCRIPTION OF WORKS

The scope of work is the replacement of 5 (five) diesel generators sets including the associated diesel generator control panels across 5 units at Duvha Power Station. The scope includes the detail design report, manufacturing, construction, factory acceptance testing, transporting, offloading, installation and commissioning of the four diesel generators including the associated diesel generator control panels and interfaces to existing auxiliaries (cooling system, starting system, bulk fuel oil system, SCADA system, etc, for Duvha Power Station.

### Important Notes

The Contractor shall perform the design and detailed engineering as detailed in the Specification (240-62772907) and Technical Schedule AB, as well as all standards and specifications referenced. In case there is a conflict between the documents that form part of the Works, the order of preference is as follows: Schedules AB, this document, the *Employer's* Diesel Generator Specification (240-62772907) followed by all other referenced documents.

In addition to the existing Scope of Work, the Contractor shall ensure that all activities related to the replacement, installation, and commissioning of the five diesel generator sets are executed by suitably qualified and competent personnel. The following additional competency requirements apply:

- The Contractor shall provide qualified and experienced auto-electricians responsible for all electrical and control-related work on the diesel generator engines. This includes, but is not limited to:
  - Engine wiring harness installation, routing, testing, and termination.
  - Connection and integration of sensors, actuators, solenoids, and engine protection devices.
  - Wiring and interface checks between the engine, diesel generator control panels, and existing station SCADA systems.
  - Troubleshooting and rectification of electrical faults during installation and commissioning.
  - Verification of compliance with OEM standards, SANS electrical standards, and Eskom-specific requirements
  
- The Contractor shall deploy qualified diesel mechanics with proven experience in the installation, alignment, and commissioning of large industrial diesel engines. Their responsibilities include:
  - Mechanical installation of diesel generator sets, including base frame mounting, vibration isolation, torqueing of critical fasteners, and alignment checks.
  - Installation and integration of engine mechanical systems such as lubrication, cooling, fuel supply, and exhaust systems.
  - Conducting pre-commissioning checks, including oil priming, coolant filling, belt tensioning, and verification of all mechanical interfaces.
  - Supporting functional testing, load testing, and post-commissioning inspections.
  - Ensuring compliance with OEM mechanical specifications and Eskom maintenance/engineering standards.

### CONTROLLED DISCLOSURE

All diesel mechanics and auto electrician must hold relevant trade qualifications and demonstrate experience with similar generator installations.

## 5.1 DIESEL GENERATOR GENERAL LAYOUT AND COMPONENTS

The Diesel Generator System shall be installed indoors and consist of the following main components:

- Diesel Generator Engine (Prime Mover)
- Generator (Synchronous machine)
- Piping to connect to an existing diesel storage tank,
- Piping to connect to the existing cooling water system (depending on what type of cooling is selected),
- Lubricating system,
- Piping to connect to the existing air starting system, (if air starting is selected).
- Exhaust system
- Power Cabling connecting the Diesel Generator/s to the Low Voltage Switchgear (Supplied by Employer)
- Control and signal cabling
- Generator Control Panel
  - Alarm, metering and annunciation
  - Synchronizing Equipment
  - Engine Management
  - Excitation System
  - Governor system
  - Diesel Generator Control and Interlocking System
  - Generator Set Synchronizing Equipment
- Diesel Generator and rotor protection equipment (including CT's)
- Engine Protection Equipment.
- Low Voltage Switchgear
- Day Fuel tank (Supplied by *Employer*)

Figure 1 below depicts a typical Single Line Diagram of The Diesel Generator System, showing the relevant communication and Control interfaces

### CONTROLLED DISCLOSURE

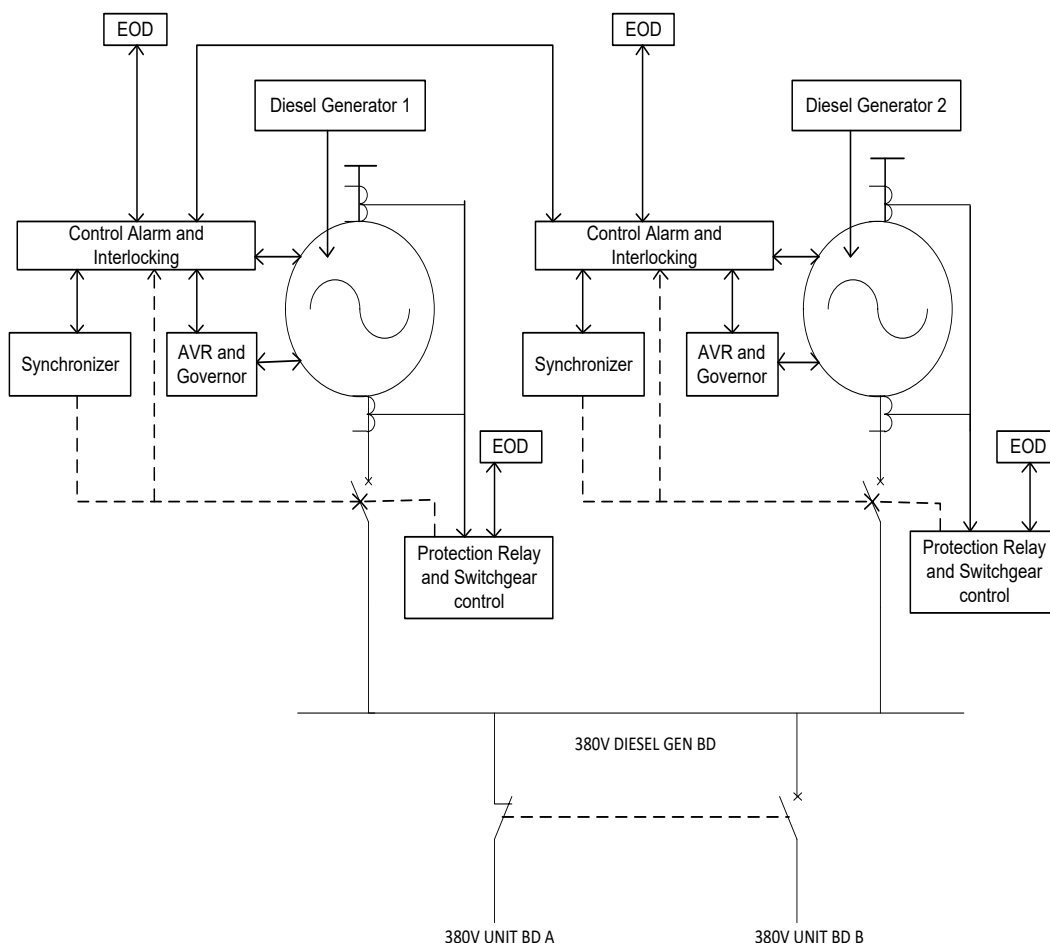

**Figure 1: Typical Diesel Generator system showing the relevant communication and Control interfaces.**

## 5.2 INTERFACE REQUIREMENTS

### 5.2.1 Diesel Generator Control panel and Controllers requirements

#### 5.2.1.1 Diesel Generator Control panel requirements

The Contractor shall decommission and replace the existing 380V Diesel Generator Control Panels for U5, U4 and U3. The replacement of the Diesel Generator Control Panel shall include replacement of the two breakers i.e the control panel shall consist of power and control circuitry, in accordance to the LV Switchgear and Control Gear Assemblies and Associated Equipment for Voltage up to and Including 1000V AC and 1500V Standard (240-56227516).

The new Diesel Generator Control Panels shall interface with the *Employer's* 380V Low Voltage Diesel Generator Board. The Employer shall provide the power cables from the 380V Low Voltage Diesel Generator Board to the new Diesel Generator Control Panel. The normal supply for all the auxiliaries shall be fed from the existing auxiliary bulk supply (380V / 230V ac, cct 51, 100 CFS) on the 380V Diesel Generator Board. The Contractor shall be responsible for termination of the power cables on the Diesel Generator Control Panel. The Contractor shall be responsible to provide the control cables for termination

### CONTROLLED DISCLOSURE

When downloaded from the EDMS, this document is uncontrolled and the responsibility rests with the user to ensure it is in line with the authorised version on the system.

between the 380V Low Voltage Diesel Generator Board and the new Diesel Generator Control Panel (see LOSS diagram).

The Contractor shall also provide power and control cables and termination schedules that connect the Diesel Generators to the Diesel Generator Control Panels. The Diesel Generator Control Panel is recommended to be installed in the existing Diesel Generator Control Panel room, see Appendix A.

### 5.2.1.2 Controllers' requirements

The two controllers (PLCs) on the existing 380V Diesel Generator Control Panel are operated at 220V ac, hence the power supply for the currently installed instrumentation is 220V ac. The recommendation is to supply the new controllers with 24V dc supply and thus its associated instrumentations.

The normal dc control supply for the new controllers shall be fed from 220V DC Board \*A (cct 16, 63A feeder) and standby dc supply from 220V DC Board \*B (cct 16, 63A feeder) via a DC/DC (220Vdc / 24Vdc) converter, through a segregated section within the Diesel Generator Control Panel. As stated in section 5.2.1.1 above, the new Diesel Generator Control Panel (LV Switchgear) is recommended to be retained in the existing Diesel Generator Control Panel room.

The estimated distance from the unit DC Boards Substation to the existing Diesel Generator room is approximately 50 meters. The *Contractor* shall size, install, route and terminate the DC cables including cable racks from 220V DC Boards to the new Diesel Generator Control Panels. .

The Diesel Generator control and interlocking shall be realized by controllers as per the list of approved controllers by the *Employer*: 240-56227589, also see Appendix D or similar devices that need to be type tested by the Employer before they can be used. The Contractor shall ensure the new controllers are capable of communicating with the instrumentations including AVR of the existing Diesel Generators on.

### 5.2.2 Special design requirements

There is a special C&I requirement to completely separate the controllers from the 380V ac supply. Two separate standalone 24Vdc controller A and 24Vdc controller B designs shall be done by the Contractor and submitted as tender returnable to the *Employer* for review and approval. The standalone controllers shall be installed front opposite the Alternator of each Diesel Generator Set (See Appendix A). No 380Vac or 230Vac or 220Vdc shall form part of these standalone panels. For this special design requirement the LV Switchgear panel is recommended to be still retained within the existing Diesel Generator Control Panel room.

**CONTROLLED DISCLOSURE**

### 5.2.3 Power Station Control System Interfaces Requirements (see figure 2)

The interface to the power station control system (DCS) is as illustrated on the PLC link block diagram (see figure 2 below). The new controllers shall have outputs as per the new EOD system.

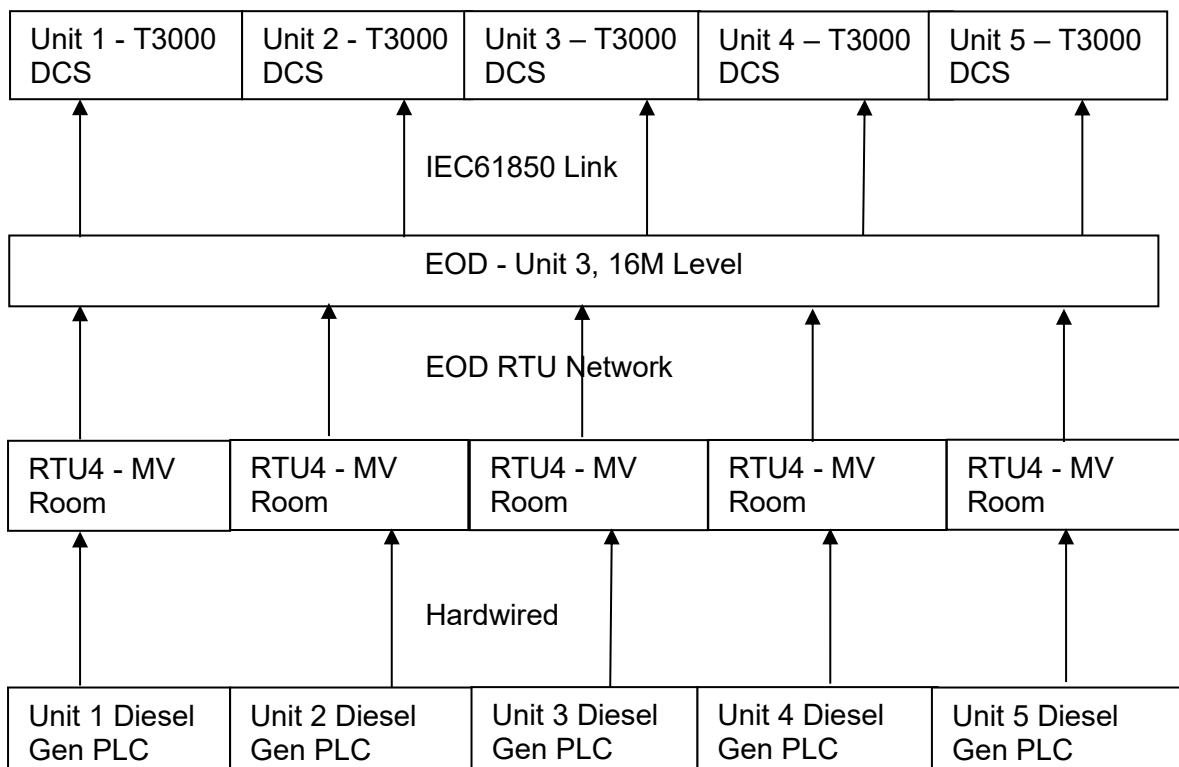

**Figure 2: PLC link block diagram**

The *Contractor* shall provide the control cables and termination schedules that connect the new controllers and EOD. Interface to be hardwired between the new controllers and unit control room. The new controllers shall be capable to implement a soft link using Ethernet based protocol to either the Unit control system or SAS. The new controllers shall have digital output capabilities.

### 5.2.4 Alarm signals and indications requirements

The design for these units shall consider compatibility with the DCS or SAS. The Diesel Generator alarms are monitored at the unit control room and at EOD (new SAS).

The below mentioned existing local plant alarms and trips signals at the Diesel Generator room shall be integrated to the mechanical and electrical alarms and trips as recommended in the Specification (240-62772907) and Schedule A. The alarms and trip indications shall be displayed as a minimum on a local annunciator and be sent to the Electrical Operated Desk and unit control room for monitoring purpose.

The existing remote plant alarms and trips signals at the unit control room and EOD shall be retained. Any additional remote alarms and trip signals at the unit control room and EOD for safe efficient operation of the plant as recommended in the Specification (240-62772907) and Schedule A shall be discussed with the *Employer* for approval. The *Employer* in collaboration with the *Contractor* shall rationalise the alarms in the detail design phase to match the existing alarms and indications at Duvha Power Station.

**CONTROLLED DISCLOSURE**

The current alarm signals available at the 380V Diesel Generator Control Panels for all the units are as indicated in figure 3 below:



**Figure 3: Current signals on 380V Diesel Generator Control Panels**

The current alarm signals available at EOD are as follows:

- Not on auto,
- Gen "A" running,
- Normal 380V supply fail,
- Emergency 380V supply fail,
- Gen "B" running,
- Gen "A" tripped,
- Gen "A" faulty,
- Gen "B" tripped,
- Gen "B" faulty,
- CB "B" fail to close,
- CB "A" fail to close,
- Control panel DC fail.

Only seven (7) binary signals (Alarm status and Running status) are currently displayed to the unit control room (U5, U4 and U3), namely:

**CONTROLLED DISCLOSURE**

- Diesel Generator A Running,
- Diesel Generator A Fault,
- Diesel Generator A Trip,
- Diesel Generator A / B Not Auto (separate signal for U1 and U2)
- Diesel Generator B Running,
- Diesel Generator B Fault,
- Diesel Generator B Trip,

**NB:** The bulk fuel oil levels shall be monitored locally on the existing bulk storage tank and local control panel, therefore the bulk storage tank shall be modified to include instrumentation for oil level monitoring.

### 5.2.5 Starting system requirements

The existing air starting system is recommended to be retained. The Contractor shall recommend the alternative starting system with detailed modifications required as optional. The new diesel generators starting system shall interface with the existing compressed system for the Unit 5 and Unit 4 Generators. The existing air starting system comprises of a compressor and receiver set which can supply compressed air at a pressure of 40 bar.

The Contractor shall supply piping to interface with the existing compressed air supply system. The Contractor shall interface with existing compressed air receivers to supply air required for starting of the engines. The current system supplies air at a pressure of 40 bar. If the required pressure of the new engine is lower than 40 bar, the Contractor shall install pressure regulating equipment to ensure the pressure of the air supplied to the engine meets the air-start requirements of the new engine.

The existing compressed air system consists of one compressor that has the following characteristics:

Number of Stages	2
Number of Cylinders	2
Rotation Speed	820 rpm
Inlet Pressure	Atmospheric
Discharge Pressure	40 bar
Free Delivery, at full load and inlet conditions	630 l/min

Figure 4 illustrates the existing compressor on Site:

**CONTROLLED DISCLOSURE**



**Figure 4: Existing Compressor**

Any work / modifications required for the air system should, as a minimum, meet the following requirements: -

- The internal velocity of the fluid shall not exceed 9 m/s
- The pipes shall meet the requirements of SANS 62-1
- The flanges shall meet the requirements of SANS 1123 – Table 3
- The corrosion protection of the Works conforms to Employer Standard: 240-101712128 Standard for internal corrosion protection of water systems, chemical tanks and vessels and associated piping with linings
- All valves, supply piping, blow-off piping, filters, condensate traps, compressors, dryers, fittings, ducting should conform to 240-105929225: Compressed Air System Standard.
- Occupational Health & Safety Act 85 of 1993

**Air Receivers:**

The existing system consists of two air receivers, A and B as illustrated in Figure 5, that have the following characteristics:

Cubic Capacity	0,165 m <sup>3</sup>
Working Pressure	40 bar
Connection to Diesel Engine	25.4 NB (1 inch) steel piping

**CONTROLLED DISCLOSURE**



**Figure 5: Existing Air Receivers**

Any newly installed / modified air system piping shall meet the following requirements as a minimum,

- The internal velocity of the fluid shall not exceed 9 m/s
- The pipes shall meet the requirements of SANS 62-1
- The flanges shall meet the requirements of SANS 1123 – Table 3
- The corrosion protection of the Works conforms to Employer Standard: 240-101712128 Standard for internal corrosion protection of water systems, chemical tanks and vessels and associated piping with linings
- All valves, supply piping, blow-off piping, filters, condensate traps, compressors, dryers, fittings, ducting should conform to 240-105929225: Compressed Air System Standard
- Meet the requirements of 240-123801640: Standard for Low Pressure Pipelines
- Occupational Health & Safety Act 85 of 1993

### **5.2.6 Fire protection requirements**

An existing fire protection system exists in the diesel generator house. Therefore no further work is required to be done on the fire protection system for the purpose of this project.

### **5.2.7 Diesel Generator room ventilation requirements**

- The air intake system must provide sufficient clean, cool air to support combustion and cooling
- The Contractor shall upgrade the room ventilation system to ensure that the internal design temperature does not exceed the outdoor ambient temperature plus 6°C under full operating conditions.

### **CONTROLLED DISCLOSURE**

- The ventilation system shall be designed to provide a minimum of 30 air changes per hour (ACH). This air change rate is intended for preliminary sizing purposes only.
- Where detailed heat gain data is available, the required ventilation airflow rate shall be determined using the following equation:

$$Q = \frac{q}{\rho c_p (t_1 - t_o)}$$

Where:

$Q$  = ventilation airflow rate (m<sup>3</sup>/s)

$q$  = total heat gain within the room (kW)

$\rho$  = air density (kg/m<sup>3</sup>)

$c_p$  = specific heat capacity of air (kJ/kg·K)

$t_1$  = allowable room air temperature (°C)

$t_o$  = outdoor ambient air temperature (°C) Cooling water supply requirements

If water cooling is chosen, the existing cooling system will to be retained. The Contractor shall interface with the existing cooling water supply in order to supply water to the new generators. Each Unit has one cooling tower which is located outside the diesel generator building and two duty pumps, one operating pump per Set (one pump for each diesel generator per unit). The existing system has the following characteristics:

Flow Rate	80 m <sup>3</sup> /h
Impeller Diameter	240 mm
Pump Rotation Speed	1450 rpm
Head	15 m
Power Output	4.3 kW
Pipe size at terminal point	80 NB

Figure 6 illustrates the cooling tower per unit:

**CONTROLLED DISCLOSURE**



**Figure 6: Cooling Tower**

Figure 7 illustrates the pumps supplying the required cooling water:

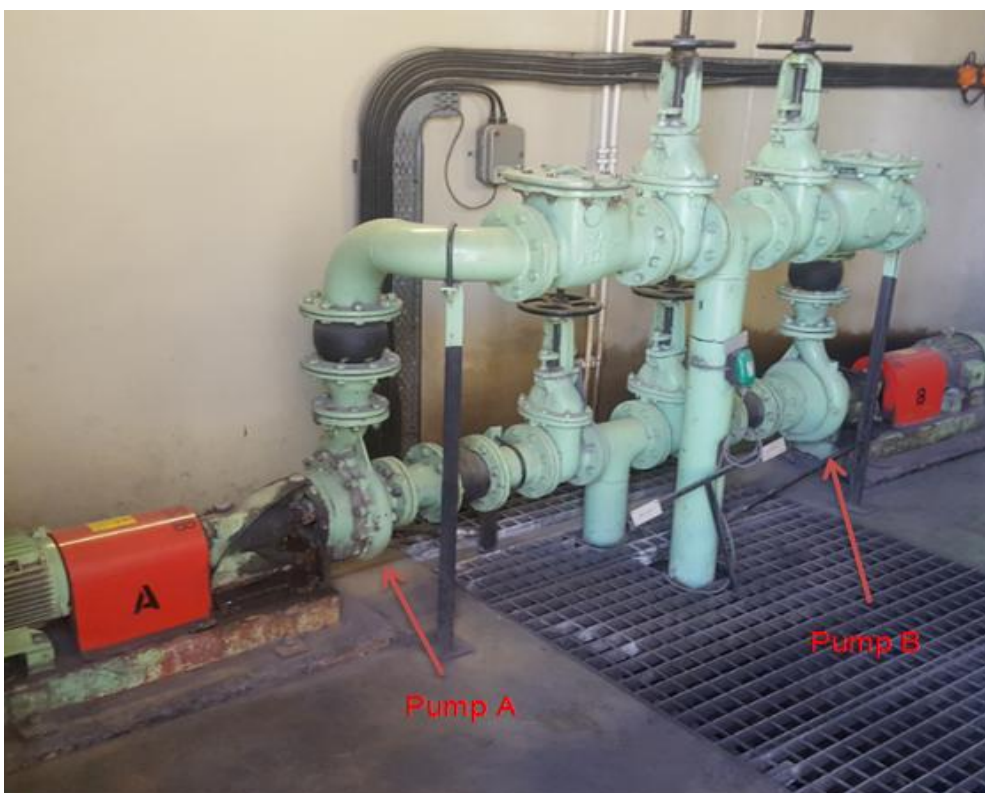

**Figure 7: Cooling Water Pump Layout**

All newly installed pipes / modifications shall meet the following requirements:

- The internal velocity of the fluid shall not exceed 2.5 m/s
- The pipes shall meet the requirements of SANS 62-1

**CONTROLLED DISCLOSURE**

When downloaded from the EDMS, this document is uncontrolled and the responsibility rests with the user to ensure it is in line with the authorised version on the system.

- The flanges shall meet the requirements of SANS 1123 – Table 3
- The corrosion protection of the Works conforms to Employer Standard: 240-101712128 Standard for internal corrosion protection of water systems, chemical tanks and vessels and associated piping with linings
- 240-108079430: Power Plant Water Systems Design Guideline
- Meet the requirements of 240-123801640: Standard for Low Pressure Pipelines
- Occupational Health & Safety Act 85 of 1993

### 5.2.8 Fuel oil system requirements

The existing diesel storage tank is recommended to be retained. The system is made up of a single tank, which supplies both set A and set B engines. The diesel storage tank, which has a storage capacity of 9000 litres, is located outside the diesel generator building as indicated in Figure 5. The diesel storage tank is fitted with only local level indication as illustrated in Figure 8. Filling is done via diesel trucks. The fuel is gravity fed from the diesel storage tank to the on-board fuel pump of Set A and Set B engines. Connection points/terminal points will be provided by means of a terminal point register.



**Figure 8: Diesel Storage Tank and Level Indication**

Any work / modifications on this system should comply with the following as a minimum:

- Flow velocity should not exceed 2.5 m/s
- Meet the requirements of 240-109835562: Diesel Oil System Design Guideline
- Meet the requirements of 240-123801640: Standard for Low Pressure Pipelines
- The flanges shall meet the requirements of SANS 1123 – Table 3
- Occupational Health & Safety Act 85 of 1993

### 5.2.9 Colour Coding requirements

All work involving painting (air, cooling water, fire and fuel oil system) shall conform to the following requirements as mentioned below. The configuration for each system is as follows:

#### **CONTROLLED DISCLOSURE**

Basic Colour*	Primary Colour*	Basic Colour*
---------------	-----------------	---------------

\*Basic colour to be painted across entire length of pipe

**Bulk Fuel Oil System:**

- Basic Color: Golden Brown
- Primary Color: White

**Water System:**

- Drinkable water
  - I. Basic Colour: Brilliant Green
  - II. Primary Colour: Corn Flower
- Demineralised Water
  - I. Basic Colour: Brilliant Green
  - II. Primary Colour: White
- Untreated Water
  - I. Basic Colour: Brilliant Green
  - II. Primary Colour: N/A

**Fire System:**

- Basic Colour: Signal Red
- Primary Colour: N/A

**Compressed Air:**

- Basic Colour: White
- Primary Colour: N/A

In addition to the above mentioned requirements, piping shall also be required to have system identification as well as flow direction arrows painted on. The stated requirements shall comply with SANS 10140 Part 1: Identification Colour Marking.

**5.2.10 C&I Requirements**

- All analogue instruments to be 4-20mA HART SMART instruments and must have 10 year drift-free guarantees for all instruments
- The controller should have a life of minimum 18 years
- Standardization of instrumentation to the refurbishment installation (e.g. brand, models)
- Instruments must be available for purchase as spares and user replaceable
- Analogue instrumentation with software limit switching is preferred to binary instrumentation
- Motor Control and Protection as per Motor OEM best practice
- Alternator Control and Protection as per Alternator OEM best practice

**CONTROLLED DISCLOSURE**

### 5.2.10.1 Applicable C&I standards

- All the instrument will be in accordance to : Field Instrument Installation Standard (240-56355754) and Pressure Measurement Systems Installation Standard (240-56355843)
- The Junction Boxes will be in accordance to the: Junction Boxes and Cable Termination (240-56355815)
- Human Machine Interface Design Requirements Standard (240-56355728)

### 5.2.11 Civil requirements

#### Structural assessment of existing structures and Design requirement for modifications

*Contractor* shall conduct a thorough investigation and structural assessment of existing structures to evaluate load-bearing capacity and identify any potential overloading risks. This assessment ensures compatibility and new equipment into existing structures and structural integrity when integrating new design elements with the existing structures. Detailed findings, including any modification requirements, shall be incorporated into the design documentation. This design pack is complete, therefore the *Employer* is able to reproduce the structural design portion of the works and reach the same outcome as the *Contractor*, where there is no need for the *Employer* to make any assumptions or inferences with regard to the designs or drawings

The *Consultant* assumes full responsibility for developing comprehensive *design* solutions for all portions of the *works* as specified by the *Employer*. This includes the preparation of preliminary and detailed designs that meet the project's technical, safety, and regulatory standards. The *Consultant's* design work must align with sound engineering principles, industry best practices, and applicable legislation, ensuring that the construction is fit for purpose and in compliance with statutory requirements, national and international engineering codes, and environmental standards.

It is the *Contractor's* responsibility to provide design and construction which is fit for purpose, in accordance with sound engineering principles and prudent industry practice. The *Contractor* and his subcontractors perform the *works* in compliance with legislation, rules and regulations, applicable national and international engineering codes, environmental standards, other applicable standards, statutory requirements and this Works Information.

#### Drawings

The *Contractor* ensures that creation, issuing and control of drawings are in accordance with the *Employer's* Engineering Drawing Standard (240-86973501).

The *Contractor* submits editable electronic drawings in MicroStation (DGN/DWG) format and in PDF format. Drawings issued to the *Employer* are not "Right Protected" or encrypted.

Drawings submitted by the *Contractor* to the *Project Manager* for acceptance includes signatures as required by Eskom Engineering Drawing Standard (240-86973501).

Electronic drawings have a water mark indicating the approval phase of a drawing and hardcopies are to be stamped to indicate the approval phase.

All drawings show full endorsement by a professionally register engineer with ECSA (including the ECSA registration number and signature on all drawings).

The *Contractor* develops as-built drawings for all the components of the *works* which he constructed. The *Contractor* submits these drawings to the *Project Manager* for his acceptance.

**CONTROLLED DISCLOSURE**

## Document submission

Each document submitted to the *Project Manager* requires a transmittal note (refer to *Employer's* template 240-71448626 for minimum metadata requirements) from the *Contractor*.

The *Contractor* submits the design reports timeously to allow for the review period by the *Project Manager*, which is defined by the *period for reply* as specified in the Contract Data, and to subsequently ensure that comments from the review are addressed without resulting in delays in delivering the *Works*

Acceptance of design reports by *Employer* does not transfer liability from the *Contractor* to the *Employer* with regard to accountability for the correctness, completeness, compliance to codes and accuracy of the design. The *Contractor* remains fully liable for the design.

## Construction requirements

The construction of the structures shall be in accordance with the contractors approved designed after the client has accepted. All construction work shall only commence after the design process has been concluded and the client has granted execution. Over and above the listed specification, the contractor shall fully comply with the listed Civil and structural Specifications.

## Temporary works

The *Contractor* is responsible for all temporary works that is used by the *Contractor* to complete the works with the requirements of the Construction Regulations. The *Contractor* submits all designs or proposals for temporary works to the *Project Manager*. The *Project Manager* reviews but does not accept the temporary works. The *Project Manager* comments on the effectiveness, necessity or risk of the temporary works or Equipment, to allow the *Contractor* to Provide the Works efficiently and without delay.

## Demolition and Dismantling

Where applicable, the *Contractor* complies with the requirements of the Construction Regulations for demolition and dismantling of structures. All rubble is removed from Site by the *Contractor* and disposed of at the designated site immediately; the location of disposal is agreed upon with the *Project Manager*.

## Concrete works

- All concrete & concrete work shall comply with: SANS 2001-CC1:2012.
- Minimum sample sizes for strength concrete (concrete test cube results) to be according to SANS 5863.
- The Contractor designs the mixes which he proposes to use in the works to meet the specified criteria including the requirements for durability, hot and cold weather, and temperature control and curing of concrete.
- Concrete is not placed in any pour to any part of the works until the Supervisor's acceptance has been given in writing, and the Contractor gives the Supervisor at least 24 hours' notice of his intention to place concrete in any pour

## Steelworks

All structural steel supports including piping, both before and after fabrication shall remain within the tolerances specified in SANS 50025. Hot rolled products of structural steels Part 2: Technical delivery conditions for nonalloy structural steels and shall be flat and straight (unless required to be formed to another shape).

All welding of structural steelwork shall be carried out in accordance with Standard for Welding requirements on Eskom Plant 240-106628253 and AWS D1.1.

## CONTROLLED DISCLOSURE

Structural steelwork shall be hot dip galvanized in accordance with SANS 14713-2 Zinc coatings - Guidelines and recommendations for the protection against corrosion of iron and steel in structures, Part 2: Hot dip galvanizing, the requirements of SANS 1200 HC, SANS 121 and Standard for the external corrosion protection of Plant, equipment and associated piping and coating – 240-106365693.

Non-destructive procedures, techniques, and acceptance criteria shall be executed in accordance with the Standard for Non-Destructive Testing (NDT) on Eskom Plant – 240- 83539994.

### Applicable Standards

- 240-56364545 - Structural Design and Engineering Standard
- 240- 83539994 - Standard for Non-Destructive Testing (NDT) on Eskom Plant
- 240-106365693 - Standard for the external corrosion protection of Plant, equipment and associated piping and coating.
- 240-106628253 - Standard for Welding requirements on Eskom Plant
- SANS 10100-1 - The Structural Use of Concrete Part 1 – Design
- SANS 10100-2 - The Structural Use of Concrete Part 2 – Materials and execution of work
- SANS 10144 - Detailing of reinforcement for concrete
- SANS 10160 - Basis of structural design and actions for buildings and industrial structures
- SANS 2001 - Construction Works

#### 5.2.12 Reliability and Availability requirements

The reticulation upstream will be retained, hence the *Contractor* shall perform the RAM (Reliability, Availability and Maintainability) studies of the equipment to be replaced downstream in the Works, in accordance with the *Employer's* System RAM Analysis Guideline [4].

The objective of the studies is to achieve the following:

- Predicting the availability and reliability of each subsystem and the complete system.
- Determining an optimized maintenance philosophy for the equipment making up the complete system.
- Performing redundancy studies on the systems.
- Using the above studies to optimize the system's spares holding.

The reliability of the system and the individual sub-systems shall be equal to or greater than 98.88%. The availability of the system and the individual sub-systems shall be equal to or greater than 98.88%.

#### 5.2.13 HAZLOC requirements

The diesel storage tanks at Duvha Power Station were classified as Zone 2 (Duvha Power Station HAZLOC File: Outside Truck Diesel Tank & Dispensing Pump), hardcopy. The *Contractor* shall also classify the equipment inside the diesel generator room in accordance with the *Employer's* Hazardous Locations Standard [5], and use the appropriate type of equipment during the designs.

#### 5.2.14 Spares requirements

All spares shall be delivered in packaging suitable for the storage of the item until it is brought into use by the *Employer*. This packaging shall remain the property of the *Employer*. Any special requirement for the storage and handling of the spares shall be identified.

### CONTROLLED DISCLOSURE

All spares shall be directly interchangeable with corresponding parts installed in the Works and shall meet the requirements of the original specification.

The Contractor shall compile a list of recommended spares to be held at the Power Station. The Contractor shall indicate any items that are recommended to be manufactured at the same time as the main Plant to obtain the benefit of concurrent manufacture.

#### **5.2.14.1 Operational spares requirements**

The Contractor shall provide an itemised and priced list of recommended operational spares and consumables for the first five (5) years of operation.

#### **5.2.14.2 Overhaul spares requirements**

The Contractor shall provide an itemised and priced list of recommended overhaul spares, if any.

#### **5.2.14.3 Strategic spares requirements**

The Contractor shall provide an itemised and priced list of recommended spares that would avoid a delay in return to service following breakdown. Justification for such a holding shall be provided.

### **5.3 SYSTEM INTEGRATION REQUIREMENT**

#### **5.3.1 Quality requirements**

No work shall be done without a QCP that is approved by the Employer. A QCP must be submitted to the Employer for all that will be done 3 days before that part of the work is to be commenced.

QCP's and related documentation shall be subject to comment and approval by the Employer's Quality Control personnel as well as Engineering. QCP's will make provision for signatures for interventions by at least the Contractor's QC Representative, the Employers QC Representative, the Employer's Engineering Department and the site AIA representative.

Intervention points will be signed as the work progresses and no back-dating will be allowed.

Notification for hold and witness points shall be in writing and shall be done at least 24 hours in advance.

The following minimum hold points must be included for the Employer's Quality Control Department:

- Approval of QCP
- Approval of General Arrangement drawings
- Electrical Schematic drawings
- Manuals for controllers, alternator, engine, etc
- Components specifications i.e. breakers, governor, etc
- Factory Acceptance Tests check sheets,
- Punch lists,
- Certificate of Compliance,
- Factory release certificate

#### **CONTROLLED DISCLOSURE**

### 5.3.2 Drawing Requirements

The creation and control of all Engineering Drawings will be in accordance to the latest revision of 240-86973501 (Engineering Drawing Standards – Common Requirements).

The Contractor shall provide detailed “As Required” arrangement/dimensional drawings for each part of work to be done. No work will commence without approval of these drawings approved by the Engineering representative of the Employer.

After the works have been completed, detailed “As-built” drawings must be provided by the Contractor. The “As-built” drawings are subject to the Employer’s Engineering representative comments and approval.

All drawings will indicate all the new installation/modified parts as well as enough of the existing pipework to which the items are connected. This must be done in sufficient detail to easily identify the location of the installation.

To aid in the production of the drawings, the Contractor may request copies of P&ID’s and the equipment’s original drawings from the Employer’s Library. The availability of current plant drawings cannot be guaranteed. Any costs associated with the creation of the drawings, including measurements taken of the equipment on site, will be for the Contractor.

### 5.3.3 Configuration Management and Document Management

#### 5.3.3.1 Document Submission requirements

All documents shall be submitted to the Eskom Documentation Centre. The Contractor is required to submit the Contractor Document Submission Schedule VDSS as per agreed dates to the Eskom Documentation Centre. Eskom will pre-allocate document numbers on the VDSS and send back to the Contractor. The VDSS is revisable and changes must be discussed and agreed upon by all parties and properly documented. Changes in the VDSS can be additional documentation to be submitted, changes in submission dates or corrections in documentation descriptions, document numbers, etc. The Contractor Document Submission Schedule VDSS shall indicate the format of documents to be submitted. Eskom shall be responsible to manage the schedule i.e. creates a document register that will be used to track submission progress of documentation by the Contractor as per the committed dates on the VDSS.

#### 5.3.3.2 Transmittal requirements

The *Contractor* lists all project documents (soft copies and hard copies) for submittal on the transmittal with the following metadata fields:

- Title of the document
- Document Unique Identification number
- Revision number
- Name of Discipline
- Reason for issuing/submission
- Sender’s detail
- Sent date
- Recipient’s Details
- Date received
- Quantity of documentation referenced on the transmittal
- Number of copies
- Format/medium submitted (eg: paper, DVD, etc)
- Sender signature

### CONTROLLED DISCLOSURE

- Recipient signature, once submitted, to acknowledge receipt

### 5.3.3.3 Plant Codification requirements

Coding of the design shall be based on the AKZ coding system and the Employer shall undertake the coding in line with its coding and labelling standards. The AKZ coding shall be applied during the design review stage(s) and cross referenced to all arrangement drawings, schematics, wiring diagrams, instructions and manuals and where practical to spare parts list/manuals. The Contractor will be required to include allocated codes to the electronic design drawings. The Contractor shall issue the Employer with the drawings as well as the equipment list for verification before commissioning.

### 5.3.3.4 Plant Labelling requirements

The *Employer* shall manufacture and install AKZ labels to identified plant items.

### 5.3.3.5 Email Subject requirements

The email subject shall as a minimum have the following:

**(Project Name\_Discipline\_Subject)**

The Contractor submits documentation to the Eskom Representative copying Eskom Documentation Centre through generic email address (drmsharedservices@eskom.co.za) Electronic copies larger than 2MB will be sent via large file transfer protocol and/or hard drives to the Project Documentation Centre. A notification email, with a transmittal note attached, shall be sent to the project generic email address. The Representative will be copied on the email as well.

- Hard copies shall be submitted to the Eskom Representative accompanied by the Transmittal Note.
- The format of the final documentation handover will be specified in the Vendor Document Submittal Schedule.

### 5.3.3.6 Documentation requirements

All documents supplied by the *Contractor* shall be subject to the Employer for approval. Documents such as QCP's, Method Statements and other documents impacting the work must be approved by the *Employer* at least 3 working days prior to commencement of the Works.

Each revision of a document or drawing shall be accompanied with a list of the comments made by the *Employer* on the previous revision if applicable and the response/corrective action taken by the *Contractor*. Changes will be recorded in a revision table contained on/in each drawing/document.

Documents and drawings shall indicate the *Employer's* drawing number as allocated by the *Employer*. The *Contractor* may have his own internal document or drawing number on the document or drawing, but where reference is made among documents or drawings, the *Employer's* number shall be used.

The *Contractor* is required to provide the following Engineering Documentation accordingly as a minimum:

- Design calculations if any.
- Approved QCP / ITP (FAT check sheets, punch list,
- General Arrangement drawings "As built"
- Wiring diagrams

## CONTROLLED DISCLOSURE

- Schematic drawings
- Updated cable schedules, including cable routing
- Termination schedule
- Instrument schedule
- Updated switchgear schedules
- Panel Interface List and related data
- Functional Logic Diagrams
- IO Block Diagrams
- Limits of Supply and Services
- Junction Box Allocations and Positions
- Operating and control philosophy of the upgraded system to be provided
- PLC's diagrams and P&IDs to be provided of the upgraded system
- Manuals for controller, alternator, engine, etc.
- Parts catalogue and or component specifications (breakers and electronic governor)
- Factory release documents
- Certificates
- Maintenance manual
- Installation Procedure
- Storage, packing and transportation instruction

#### **5.3.3.7 Documentation**

For consistency it is important that all documents used within the project follow the same layout, style and formatting standard. Therefore the contractor shall ensure that the 240-76992014: Technical Document and Record Management Work Instruction is used for any documentation requirements.

#### **5.3.3.8 General Requirement**

The Contractor includes the Employer's drawing number in the drawing title block. This requirement only applies to design drawings developed by the Contractor and his Subcontractors. It does not apply to drawings developed by manufacturers for equipment and material such as valves, instruments, etc. Drawing numbers will be assigned by the Employer as drawings are developed.

The project name shall be listed on all drawings, including manufacturers' drawings. Tag numbers and equipment names shall be listed on all manufacturers' drawings. A separate sheet may be attached to the submittal if needed to adequately list all tag numbers associated with the drawings such as valves or instruments which may have numerous tag numbers associated with it.

The language of all documentation shall be in the English language. The units of measure shall be metric.

The Contractor retains project design calculations and information for the entire life cycle of the plant and provides these to the Employer on prior written notice at any time notwithstanding the expiry or termination of the contract.

### **CONTROLLED DISCLOSURE**

### 5.3.3.9 Engineering Change Management

All Design change management shall be performed in accordance to the latest revision of the Eskom Project Change Management Procedure (240-53114026) and the Employer shall ensure that Contractor is provided with latest revisions of this procedure. Any uncertainty regarding this procedure should be clarified with the Employer and clarification updates should be reflected in updated versions of this procedure.

### 5.4 RISK AND ISSUE REGISTER

- Unavailability of key design documentation for the existing system.
- Unavailability of the system due to single point of failure for the fuel oil system, and water cooling system.

### 5.5 DRAWINGS ISSUED BY THE EMPLOYER

This is a list of drawings issued by the Employer at or before the Contract Date and which apply to this contract. It is the responsibility of the Contractor to verify the correctness of the drawings dimensions.

Note: Some drawings may contain both Works Information and Site Information.

Drawing list		
Drawing number	Revision	Description
0.57/19361	2	Diesel Generator Plant Room Layout
0.57/13654	2 sheet 1 (3)	Diesel Generator Control Panel General Arrangement
0.57/19852	3	Unit diesel generator house U3 plan
0.57/13640	3	Schematic diagram of fire control systems and associated services
0.57/1035	20	Duvha Power Station layout
24.57/46865	0 sheet 2	U4 fire protection diesel generator and generator transformers
0.57/18644	0	Diesel Generator house concrete layout of extension
0.57/18228	0	Alternator
0.57/19361	2	Plant room layout, Unit 1
0.57/19852	3	Unit 3 Diesel Generator House plan, sections and elevations

- Switchgear schedule for unit 380V Diesel Generator Board, and
- Schematic drawings for existing Diesel Generator Control Panel

### CONTROLLED DISCLOSURE

## 6. AUTHORISATION

This document has been seen and accepted by:

Name	Designation
Lesedi Mabitla	System Engineer– Electrical
Masilo Sekhele	Electrical Engineer – Duvha Power Station
Thabiso Masethe	Auxiliary Engineer – Duvha Power Station
Nomfundo Mdlokovana	Lead Discipline Engineer – C&I CoE
Sibonokuhle Tapala	Snr Auxiliary Engineer
Andile Nqayane	Electrical Engineering Manager

## 7. REVISIONS

Date	Rev.	Compiler	Remarks
March 2017	0	D Kunene	Draft document for review
April 2017	0.3	D Kunene	Consolidated comments from C&I and interim EIDR
May 2017	0.4	D Kunene	LPS input provided
May 2017	0.5	D Kunene	Doc updated to prepare for EIDR
May 2017	0.6	D Kunene	Consolidated EIDR comments
June 2017	0.7	D Kunene	Consolidated C&I IDR comments
June 2017	1	D Kunene	Final report
July 2017	2	D Kunene	Consolidated comments from the CCCC
July 2024	3	N Nhlengethwa	Scope change to 5 diesel generators, one generator on each unit.
March 2026	4	L Mabitla	Scope change to include auxiliary scope.

## 8. DEVELOPMENT TEAM

Andile Nqayane  
 Lesedi Mabitla  
 Masilo Sekhele

## 9. ACKNOWLEDGEMENTS

- Goldstone Mungwe
- Jonathan Magano
- David Kunene

### CONTROLLED DISCLOSURE

When downloaded from the EDMS, this document is uncontrolled and the responsibility rests with the user to ensure it is in line with the authorised version on the system.



### 11. APPENDIX B: GENERAL ARRANGMENT FOR EXISTING DIESEL GENERATOR CONTROL PANEL

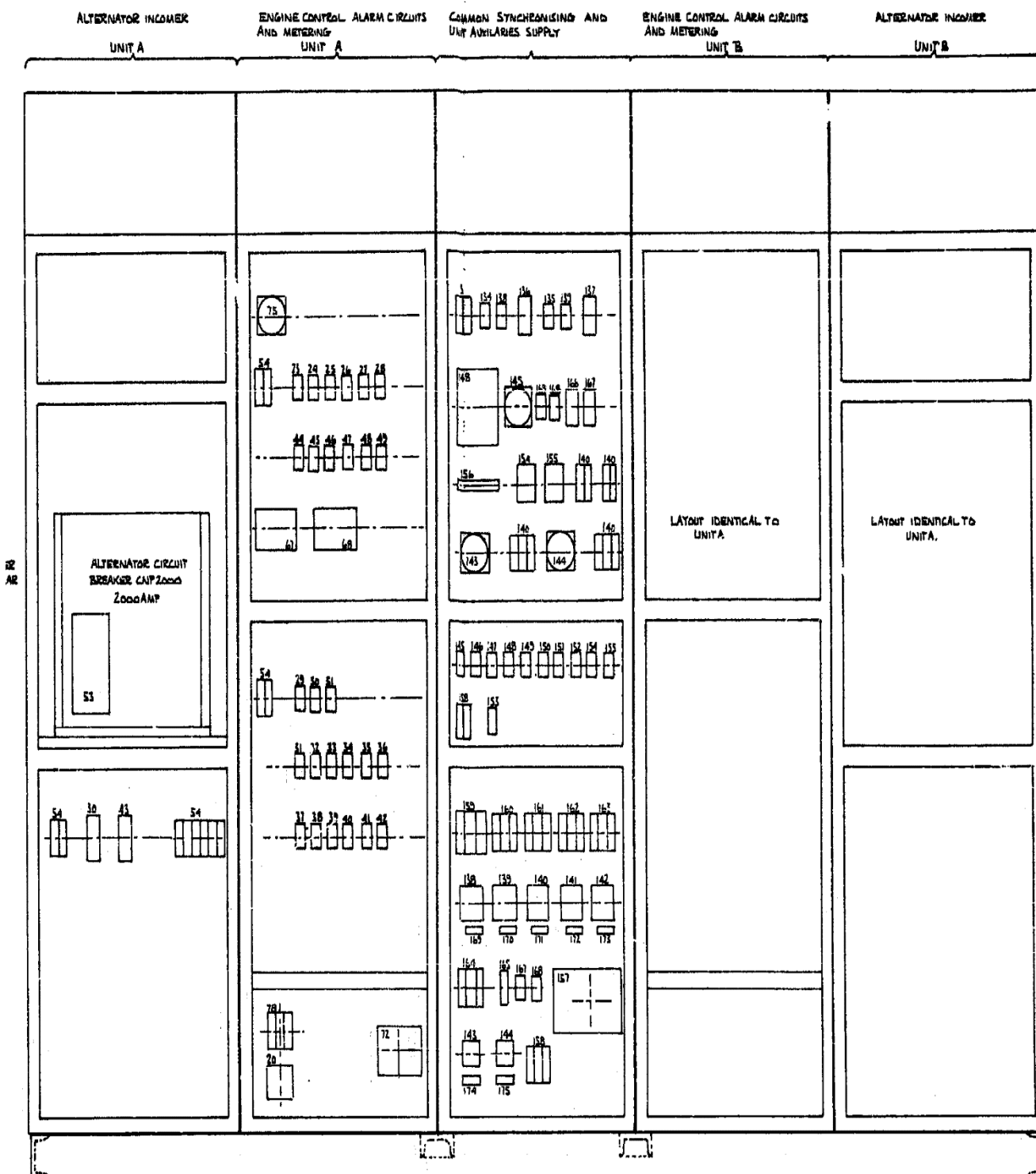

**CONTROLLED DISCLOSURE**

12. APPENDIX C: UNIT 380V ESSENTIAL SUPPLY SYSTEM SINGLE LINE DIAGRAM

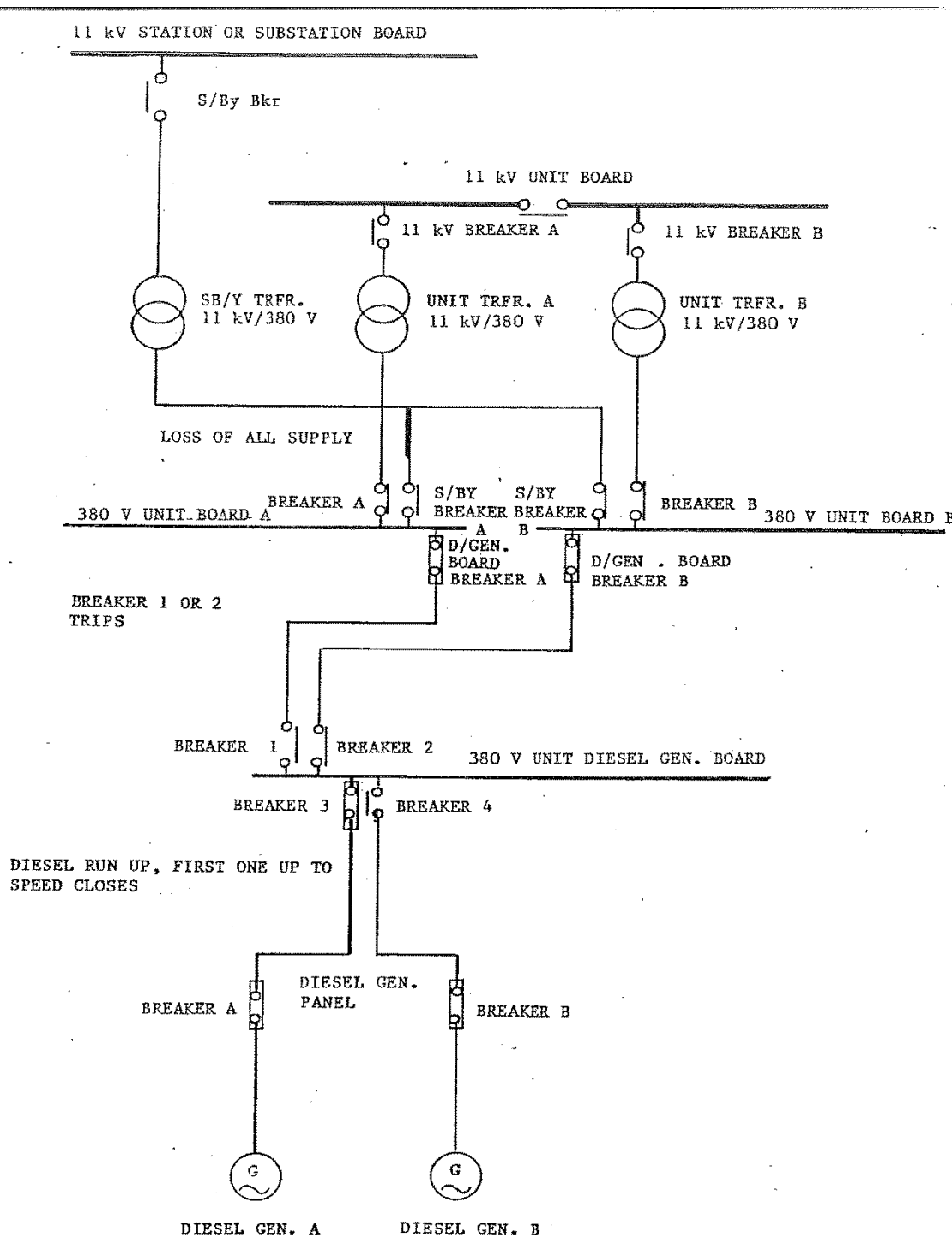

Fig. 67: Total loss of supply to 380 V unit boards A and B

**CONTROLLED DISCLOSURE**

**13. APPENDIX D: REFERENCE FOR LIST OF APPROVED CONTROLLERS FOR ESKOM**

Mr Jiiimmy Creighton	<b>Date:</b>
TEL: 082 902 2313	1 <sup>st</sup> September 2016
Trc2@mweb.co.za	
	<b>Enquiries: P Shott</b>
	Tel +27 13 693 3514
	eMail : peter.shott@eskom.co.za

Dear Sir,

**Acceptance Tests: – Deepsea plc Products**

- 1 x DSE8610 MK 2 Genset controller
- 1 x DSE8660 MK2 Mains controller

The abovementioned products submitted to us have been evaluated and tested. The products are suitable for use within ESKOM Generation.

The products listed above, will be placed on our list of approved products for Power Station use (GGS0852)

Please contact us should you require any further information.

Yours sincerely,



P Shott  
Senior Engineer  
Specialised Testing Services  
PTM  
Group Technology  
ESKOM

**CONTROLLED DISCLOSURE**