

**ROADS AND TRANSPORT DEPARTMENT
IRPTN DIVISION**



TENDER REFERENCE: RTD 04 2023/24

**INTEGRATED RAPID PUBLIC TRANSPORT NETWORK (IRPTN)
PROJECT:
UPGRADING OF IRPTN LINE 3 INTERIM OPERATIONS: PRINCE'S
PARK AND BUS STOPS/BAYS ALONG WF NKOMO STREET**

VOLUME 1 of 3

A Tender for Category 7CE or higher CIDB registered
Contractors

ISSUED BY:	PREPARED BY:
The Group Head: Roads and Transport <u>IRPTN DIVISION</u> PO Box 1409 PRETORIA 0001 Tel: 012 358-1064	Imbawula Civil Projects (Pty) Ltd PLOT 70, 1463 TIENIE STREET ANDEON A/H PRETORIA WEST 0183 Tel: 012 372 3807

Registered Name of Tenderer:	
Trading Name of Tenderer:	
Registration No. of Entity:	
Contact Person:	CoT Vendor No:
Tel. No:	E-Mail Address:
Cell No:	Fax No:
CIDB CRS Number (s):	

TABLE OF CONTENTS

VOLUME 1 OF 3

PART T1	TENDERING PROCEDURES
PART T2	RETURNABLE DOCUMENTS
PART T3	SUBCONTRACTINGPROCEDURES
PART C1	AGREEMENTS AND CONTRACT DATA

VOLUME 2 OF 3

PART C2	PRICING DATA
----------------	--------------

VOLUME 3 OF 3

PART C3	SCOPE OF WORK
PART C4	SITE INFORMATION
PART C5	ANNEXURES

CONTENTS

DESCRIPTION		COLOUR
<u>VOLUME 1 (This volume)</u>		
<u>TENDER</u>		
PART T1	TENDERING PROCEDURES	
	T1.1 Tender Notice and Invitation to Tender	White
	T1.2 Tender Data	Pink
	T1.3 Standard Conditions of Tender	Pink
PART T2	RETURNABLE DOCUMENTS	Yellow
	T2.1 List of Returnable Documents	Yellow
	RD. A Tender Evaluation	Yellow
	RD. B Preferential Procurement	Yellow
	RD.C Additional for Tender Evaluation	Yellow
	RD. D Quality Evaluation	Yellow
	RD. E Other Data	Yellow
	T2.2 Returnable Schedules	Yellow
PART T3	SUBCONTRACTING PROCEDURES	Yellow
<u>CONTRACT</u>		
PART C1	AGREEMENTS AND CONTRACT DATA	
	C1.1 Form of Offer	Yellow
	C1.2 Contract Data	Yellow
	C1.3 Form of Guarantee	White
	C1.4 Guarantee of Cash Deposit	White
	C1.5 Health and Safety Agreement	White
<u>VOLUME 2</u>		
PART C2	PRICING DATA	
	C.2.1 Pricing Assumptions	Yellow
	C.2.2 Pricing Schedule	Yellow
	C2.3 Calculation of Tender Sum	Yellow
<u>VOLUME 3</u>		
PART C3	SCOPE OF WORK	
	C3.1 Description of the Works	Blue
	C3.2 Engineering	Blue
	C3.3 Procurement	Blue
	C3.4 Construction	Blue
	C3.5 Management	Blue
PART C4	SITE INFORMATION	Green
PART C5	ANNEXURES	
	Tender Drawings	White

PART T1: TENDER PROCEDURES

TABLE OF CONTENTS

- T1.1 TENDER NOTICE AND INVITATION TO TENDER
- T1.2 TENDER DATA
- T1.3 STANDARD CONDITIONS OF TENDER

T1.1 TENDER NOTICE AND INVITATION TO TENDER

**RTD 04 2023/24 CITY OF TSHWANE
OFFICE OF THE GROUP HEAD: TRANSPORT**



Competent and experienced contractors are hereby invited to tender for:

CONTRACT: RTD 04 2023/24 IRPTN PROJECT:
UPGRADING OF IRPTN LINE 3 INTERIM OPERATIONS: PRINCE'S PARK AND BUS STOPS/BAYS ALONG
WF NKOMO STREET

Tenderers should have a CIDB rating of 7CE or higher. **Tenders will be received until 10h00 on the 20th March 2024.** Tenders will be received on the closing dates and times shown, must be enclosed in sealed envelopes, bearing the applicable tender heading and tender number, as well as the closing time and due date, and must be addressed to:-

**THE CHIEF FINANCIAL OFFICER:
FINANCE DEPARTMENT,
SUPPLY CHAIN MANAGEMENT UNIT,
PRETORIA, 0001**

Tenders must be submitted in the TENDER BOX situated at the **TSHWANE HOUSE, (TENDER BOX situated at the gate, (Tender Box at City of Tshwane: Supply Chain Management, Tshwane House, 320 Madiba Street, Pretoria CBD, 0002.** Tenders will be opened at the latter address at the time indicated.

The tender documents will be available on the City of Tshwane official website (www.tshwane.gov.za) and www.etenders.gov.za

Tenders will be evaluated firstly on Technical ability and secondly according to the Financial plus preferences method.

A tender must remain valid for a period of **90 days** from the closing date for the submission of tenders, during which period the tender may not be amended or withdrawn and may be accepted by the Municipality at any time during this period.

A Compulsory Clarification Meeting: There will be held on **1st March 2024 Sammy Marks Council Chamber, 1st Floor, Sammy Marks Square, Cnr Lilian Ngoyi and Madiba Street, Pretoria Central @ 10h00.** Prospective tenderers must already be in possession of the tender document and have familiarised themselves with the contents. The meeting with a representative of the Employer will take place on the specified date and time.

ENQUIRIES: Ms Itumeleng Rachidi
Tel (Office): 012 358 5675

Fax: 086 215 0198
E-Mail: itumelengke@TSHWANE.GOV.ZA

T1.2 TENDER DATA

The conditions of tender are the Standard Conditions of Tender as contained in Annexure C of Standard for Uniformity in Construction Procurement (August 2019), bound into Section T1.3.

The Standard Conditions of Tender makes several references to the Tender Data. The Tender Data shall have precedence in the interpretation of any ambiguity or inconsistency between it and the Standard Conditions of Tender to which it mainly applies.

CLAUSE NUMBER		TENDER DATA
C.1.1	Actions	The Employer is City of Tshwane Metropolitan Municipality
C.1.2	Tender Documents	<p><u>Volume 1 of 3</u></p> <p><u>THE TENDER</u></p> <p>Part T1: Tendering Procedures</p> <p style="padding-left: 20px;">T1.1 – Tender Notice and Invitation to Tender</p> <p style="padding-left: 20px;">T1.2 – Tender Data</p> <p style="padding-left: 20px;">T1.3 – Standard Conditions of Tender</p> <p>Part T2: Returnable Documents</p> <p style="padding-left: 20px;">T2.1 – List of Returnable Documents</p> <p style="padding-left: 20px;">T2.2 – Returnable Schedules</p> <p><u>THE CONTRACT</u></p> <p>Part C1: Agreements and Contract Data</p> <p style="padding-left: 20px;">C1.1 – Form of Agreement</p> <p style="padding-left: 20px;">C1.2 – Contract Data</p> <p style="padding-left: 20px;">C1.3 – Form of Guarantee</p> <p style="padding-left: 20px;">C1.4 – Guarantee or Cash Deposit</p> <p style="padding-left: 20px;">C1.5 – Health and Safety Agreement</p> <p><u>Volume 2 of 3</u></p> <p>Part C2: Pricing Data</p> <p style="padding-left: 20px;">C2.1 – Pricing Assumptions</p> <p style="padding-left: 20px;">C2.2 – Pricing Schedule</p> <p style="padding-left: 20px;">C2.3 – Calculation of Tender Sum</p> <p><u>Volume 3 of 3</u></p> <p>Part C3: Scope of Work</p> <p style="padding-left: 20px;">C3.1 – Description of the Works</p> <p style="padding-left: 20px;">C3.2 – Engineering</p> <p style="padding-left: 20px;">C3.3 – Procurement</p> <p style="padding-left: 20px;">C3.4 – Construction</p> <p style="padding-left: 20px;">C3.5 – Management</p> <p>Part C4: Site information</p> <p>Part C5: Annexures</p> <p style="padding-left: 20px;">Tender Drawings</p>

CLAUSE NUMBER		TENDER DATA	
C.1.4	Communication and Employer's Agent	Agent:	Mr. Tamsanqa Tom
		Address:	Imbawula Civil Projects Plot 70, 1463 Tienie Street Andeon A/H Pretoria west 0183
		Tel:	(012) 372 3708
		Fax:	
		E-Mail:	admin@imbawulacp.co.za
C1.6.2.3		Not applicable.	
C.2.1	Eligibility	<p>Mandatory requirements</p> <p>Only those Tenderers who satisfy the following eligibility criteria are eligible to submit tenders:</p> <ul style="list-style-type: none"> • Tenderers who are registered with the CIDB in a contract grading designation equal to or higher than a contractor grading designation determined in accordance with the sum tendered for 7CE class of construction work, • The Safety Officer must be Professionally Registered with South African Council for the Project, and Construction Management Professionals (SACPCMP), • The Construction Manager with minimum B-Tech or BSc in Civil Engineering, • The Construction Manager must be Professionally Registered as either Pr. Eng (ECSA) or Pr. Tech Eng (ECSA) or Pr. CM (SACPCMP) • Site Agent – Civil Works with minimum B-Tech/Advanced Diploma – Civil Engineering or BSc in Civil Engineering, • Site Agent – Electrical Works with minimum National Diploma: Electrical and 3-phase wireman's license, <p>CV Submission to include the proof of identity for all personnel. Non submission of CV's with supporting documents will be deemed non-responsive,</p> <p>Joint Ventures are eligible to submit tenders provided that:</p> <ol style="list-style-type: none"> a) Every member of a joint venture is registered with the CIDB prior to the closing date of tenderers; b) The lead partner has a contractor grading designation in the 6CE class of construction work; and c) The combined contractor grading designation calculated in accordance with the Construction Industry Development Regulations is equal to or higher than a contractor designation in accordance with the sum tendered for 7CE class of construction work or a value determined in accordance with Regulation 25(1B) or 25(7A) of the Construction Industry Development Regulations. 	

		<p>A Tenderer will not be eligible to submit a tender if:</p> <ul style="list-style-type: none"> (a) Tenderer submitting the tender is under restrictions or has principals who are under restriction to participate in the Employers procurement due to corrupt or fraudulent practices; (b) the Tenderer does not have the legal capacity to enter the contract; (c) the Tenderer submitting the tender is insolvent, in receivership, bankrupt or being wound up, has his/ her affairs administered by a court or judicial officer, has suspended his/ her business activities, or is subject to legal proceedings in respect of the foregoing; (d) the Tenderer does not comply with the legal requirements stated in the Employers procurement policy; (e) the Tenderer cannot provide proof that he is in good standing with respect to duties, taxes, levies and contributions required in terms of legislation applicable to the work in the contract; (f) has a score below 70 as determined below.
--	--	---

CLAUSE NUMBER	TENDER DATA																																																	
	<p>Only those tenderers who score a minimum of 70 points in respect of the Functionality Scoring.</p> <p>Experience will be measured as follows:</p> <table style="width: 100%; border-collapse: collapse;"> <tr> <td style="width: 70%;">TENDERER EXPERIENCE</td> <td style="text-align: right;">51 Points</td> </tr> <tr> <td>QUALITY MANAGEMENT</td> <td style="text-align: right;">9 Points</td> </tr> <tr> <td>KEY PERSONNEL</td> <td style="text-align: right;">40 Points</td> </tr> <tr> <td>Total</td> <td style="text-align: right;">100 Points</td> </tr> </table> <p>Evaluation criteria on the above:</p> <table border="1" style="width: 100%; border-collapse: collapse;"> <thead> <tr> <th style="width: 30%;">CRITERIA</th> <th style="width: 20%;">SUB-CRITERIA</th> <th style="width: 10%;">SCALE</th> <th style="width: 10%;">WEIGHT</th> <th style="width: 10%;">HIGHEST POSSIBLE SCORE</th> </tr> </thead> <tbody> <tr> <td colspan="2">TENDERER EXPERIENCE:</td> <td></td> <td></td> <td style="text-align: center;">Max 51</td> </tr> <tr> <td rowspan="3">A similar project is a road project involving layer works and an asphalt topping, with a minimum value of R20million, over the past 15 years. Failure to submit, will result in zero score allocated</td> <td>• 1 similar project in excess of R20 million value completed</td> <td style="text-align: center;">17</td> <td style="text-align: center;">1</td> <td style="text-align: center;">51</td> </tr> <tr> <td>• 2 similar projects in excess of R20 million value for each completed</td> <td style="text-align: center;">34</td> <td></td> <td></td> </tr> <tr> <td>• 3 similar projects in excess of R20 million value for each completed</td> <td style="text-align: center;">51</td> <td></td> <td></td> </tr> <tr> <td colspan="2">QUALITY MANAGEMENT:</td> <td></td> <td></td> <td style="text-align: center;">Max 9</td> </tr> <tr> <td rowspan="2">Describe Quality Management System by way of extract from the ISO – 9001-2015 Certification, or extracts from Internal Quality Management Systems</td> <td>• Valid ISO Certificate to be included in respect of construction works</td> <td style="text-align: center;">9</td> <td style="text-align: center;">1</td> <td style="text-align: center;">9</td> </tr> <tr> <td>• Signed Internal Quality Management system to be included on company letter head</td> <td style="text-align: center;">2</td> <td></td> <td></td> </tr> </tbody> </table>					TENDERER EXPERIENCE	51 Points	QUALITY MANAGEMENT	9 Points	KEY PERSONNEL	40 Points	Total	100 Points	CRITERIA	SUB-CRITERIA	SCALE	WEIGHT	HIGHEST POSSIBLE SCORE	TENDERER EXPERIENCE:				Max 51	A similar project is a road project involving layer works and an asphalt topping, with a minimum value of R20million, over the past 15 years. Failure to submit, will result in zero score allocated	• 1 similar project in excess of R20 million value completed	17	1	51	• 2 similar projects in excess of R20 million value for each completed	34			• 3 similar projects in excess of R20 million value for each completed	51			QUALITY MANAGEMENT:				Max 9	Describe Quality Management System by way of extract from the ISO – 9001-2015 Certification, or extracts from Internal Quality Management Systems	• Valid ISO Certificate to be included in respect of construction works	9	1	9	• Signed Internal Quality Management system to be included on company letter head	2		
TENDERER EXPERIENCE	51 Points																																																	
QUALITY MANAGEMENT	9 Points																																																	
KEY PERSONNEL	40 Points																																																	
Total	100 Points																																																	
CRITERIA	SUB-CRITERIA	SCALE	WEIGHT	HIGHEST POSSIBLE SCORE																																														
TENDERER EXPERIENCE:				Max 51																																														
A similar project is a road project involving layer works and an asphalt topping, with a minimum value of R20million, over the past 15 years. Failure to submit, will result in zero score allocated	• 1 similar project in excess of R20 million value completed	17	1	51																																														
	• 2 similar projects in excess of R20 million value for each completed	34																																																
	• 3 similar projects in excess of R20 million value for each completed	51																																																
QUALITY MANAGEMENT:				Max 9																																														
Describe Quality Management System by way of extract from the ISO – 9001-2015 Certification, or extracts from Internal Quality Management Systems	• Valid ISO Certificate to be included in respect of construction works	9	1	9																																														
	• Signed Internal Quality Management system to be included on company letter head	2																																																

CLAUSE NUMBER		TENDER DATA						
		CRITERIA	SUB-CRITERIA	SCALE		WEIGHT	HIGHEST POSSIBLE SCORE	
		KEY PERSONNEL:			YEARS OF EXPERIENCE	NUMBER OF PROJECTS COMPLETED OF SIMILAR NATURE	Max 40	
		The Tenderer shall schedule the following Key Personnel who would be assigned to this Contract.	• Construction Manager position	<ul style="list-style-type: none"> • 10+ = 6 points • 7 to 9 = 4 points • 5 to 6 = 2 points 	<ul style="list-style-type: none"> • 5+ = 6 points • 3 to 4 = 4 points • 1 to 2 = 2 points 	1	12	
			• Site Agent – Civil Works position	<ul style="list-style-type: none"> • 10+ = 5 points • 7 to 9 = 4 points • 3 to 6 = 2 points 	<ul style="list-style-type: none"> • 5+ = 5 points • 3 to 4 = 4 points • 1 to 2 = 2 points 	1	10	
			• Site Agent – Electrical Works position	<ul style="list-style-type: none"> • 10+ = 5 points • 7 to 9 = 4 points 3 to 6 = 2 points 	<ul style="list-style-type: none"> • 5+ = 5 points • 3 to 4 = 4 points 1 to 2 = 2 points 	1	10	
			• Occupational Health & Safety Officer position	<ul style="list-style-type: none"> • 3+ = 4 points • 1 to 2 = 2 points • Less than 1 = 0 points 	<ul style="list-style-type: none"> • 2+ = 4 points • 1 = 2 points • 0 = 0 points 	1	8	
			In order to give effect to the above, the returnable documents, Forms RD.D3, RD.D5, and RD.D8 to RD.D11 shall be completed and calculated on Form RD.D15.					
C.2.2	Cost of Tendering	The employer will not compensate the tenderer for any costs incurred in attending interviews or making any submissions in the office of the employer.						
C.2.7	Clarification meeting	<p>The arrangements for a compulsory clarification meeting are as stated in the tender notice and invitation to tender (T1.1). The attendance of the clarification meeting is compulsory.</p> <p>Confirmation of attendance will be recorded on site in the attendance register to be signed by all tenderers. Addenda will be issued to and tenders received from those tendering entities appearing on the attendance register.</p>						

CLAUSE NUMBER		TENDER DATA
C.2.8	Seek clarification	<p><u>Replace</u> the clause with the following:</p> <p><i>Request clarification of the tender documents, if necessary, by notifying the employer at least <u>seven working days</u> before the closing time stated in the tender data.</i></p>
C.2.9	Insurance	<p><u>Add</u> the following to the clause</p> <p><i>The employer will not provide insurance cover and the contractor shall arrange all his own insurance as follows:</i></p> <ul style="list-style-type: none"> • <i>Insurance for Works and Contractor's equipment</i> • <i>Insurance for Contractor's Personnel</i> • <i>General public liability</i> • <i>SASRIA</i>
C.2.12	Alternative tender offers	No alternative tender offers will be considered.

C.2.13	Submitting a tender offer	Submit one tender offer only, either as a single tendering entity or as a member in a joint venture to provide the whole of the works, services or supply identified in the contract data described in the scope of work, unless stated otherwise in the tender data.
C2.13.1		Return all returnable documents to the employer after completing them in their entirety, by writing legibly in non-erasable ink.
C2.13.2		Submit the parts of the tender offer communicated on paper as an original plus the number of copies stated in the tender data, with an English translation of any documentation in a language other than English, and the parts communicated electronically in the same format as they were issued by the employer.
C2.13.3		Sign the original and all copies of the tender offer where required in terms of the tender data. The employer will hold all authorized signatories liable on behalf of the tenderer signatories for tenderers proposing to contract as joint ventures shall state which of the signatories is the lead partner whom the employer shall hold liable for the purpose of the tender offer.
C2.13.4		Seal the original tender offer and each of the tender offer as separate packages marking the packages as ORIGINAL and COPY. Each package shall state on the outside of the employer's address and identification details stated in the tender data, as well as the tenderers name and contact address.
C2.13.5		<p>The identification details are: Tender Reference: RTD 04 2023/24 Tender Description: INTEGRATED PUBLIC TRANSPORT NETWORK (IRPTN) PROJECT: UPGRADING OF IRPTN LINE 3 INTERIM OPERATIONS: PRINCE'S PARK AND BUS STOPS/BAYS ALONG WF NKOMO STREET</p> <p>Closing Time: 10H00am Closing Date: 20 March 2024</p> <p>Each tender shall be enclosed in a sealed envelope, bearing the correct identification details and shall be placed in the tender box located at:</p> <p>TENDER BOX situated at the gate, (Tender Box at City of Tshwane: Supply Chain Management, Tshwane House, 320 Madiba Street, Pretoria CBD, 0002.</p> <p>This address is 24 hours available for delivery of tender offers.</p>
C2.13.6		Bidders are required to submit electronic copies of the bid either by memory stick/USB flash drive together with the hard copy of the Bid/Proposals
C2.13.7		Seal the original tender offer and copy packages together in an outer package that states on the outside only the employer's address and identification details as stated in the tender data.
C2.13.8		Accept that the employer will not assume any responsibility for the misplacement or premature opening of the tender offer if the outer package is not sealed and marked as stated
C2.13.9		Accept that tender offers submitted by facsimile or e-mail will be rejected by the

C.2.13.4		<p>employer, unless stated otherwise in the tender data.</p> <p>Only authorised signatories may sign the original and all copies of the tender offer where required. In the case of a <u>One-Person Concern</u> submitting a tender, this shall be clearly stated.</p> <p>In the case of a <u>Company</u> submitting a tender, include a copy of a resolution by its board of directors authorising a director or other official of the company to sign the documents on behalf of the company.</p> <p>In the case of a <u>Close Corporation</u> submitting a tender, include a copy of a resolution by its members authorising a member or other official of the corporation to sign the documents on each member's behalf.</p> <p>In the case of a <u>Partnership</u> submitting a tender, all the partners shall sign the documents, unless one partner or a group of partners has been authorised to sign on behalf of each partner, in which case proof of such authorisation shall be included in the Tender.</p> <p>In the case of a <u>Joint Venture/Consortium</u> submitting a tender, include a resolution of each company of the joint venture together with a resolution by its members authorising a member of the joint venture to sign the documents on behalf of the joint venture.</p> <p><u>Accept that failure to submit proof of authorisation to sign the tender shall result in the tender offer being regarded as non-responsive.</u></p>
C.2.15	Closing time	The closing time for submission of tender offers is stated in the tender notice and invitation to tender.
C.2.16	Tender offer validity	The tender offer validity period is 90 days.
C.2.18	Provide other material	The tenderer shall, when requested by the employer to do so, submit the names of all management and supervisory staff that will be employed to supervise the labour-intensive portion of the works together with satisfactory evidence that such staff members satisfy the eligibility requirements.
C.2.20	Submit securities, bonds, policies, etc.	The tenderer is required to submit with his tender a letter of intent from an approved banker/insurance company as per Form RD.C.13 undertaking to provide the performance Guarantee for GCC – 3 rd Edition (2015), Clause 6.2 to the format included in Section C1.3 of this procurement document.
C.2.24	Canvassing and obtaining of additional information by tenderers	<p><u>Add</u> the following new clause</p> <p>The Tenderer shall not make any attempt either directly or indirectly to canvass any of the Employer's officials or the Employer's agent in respect of his tender, after the opening of the tenders but prior to the Employer arriving at a decision thereon.</p> <p>The Tenderer shall not make any attempt to obtain particulars of any relevant information, other than that disclosed at the opening of tenders.</p>

C.2.25	Prohibitions on awards to persons in service of the state	<p><u>Add</u> the following new clause</p> <p>Regulation 44 of the Supply Chain Management regulations states that the Public Entity may not make an award to a person:</p> <ul style="list-style-type: none"> a) who is in the service of the state; or b) if that person is not a natural person, of which any director, manager, principal shareholder or stakeholder is a person in the service of the state; or c) a person who is an advisor or consultant contracted with the municipality or municipal entity. <p>In the service of the state means to be –</p> <ul style="list-style-type: none"> f) A member of:- <ul style="list-style-type: none"> i. any municipal council; ii. any provincial legislature; or iii. the National Assembly or the National Council of Provinces; b) a member of the board of directors of any municipal entity; c) an official of any municipality or municipal entity; d) an employee of any national or provincial department; e) provincial public entity or constitutional institution within the meaning of the Public Finance Management Act, 1999 (Act No.1 of 1999); f) a member of the accounting authority of any national or provincial public entity; or g) an employee of Parliament or a provincial legislature. <p>In order to give effect to the above, the questionnaire for the declaration of interests in the tender of persons in service of state in part T2 of this procurement document must be completed.</p>
C.2.28	Tax	<p><u>Add</u> the following new clause</p> <p>A valid Tax Status Pin must be submitted with this tender document. In the case of a Joint Venture/Consortium the tax clearance certificate must be for the Joint Venture/Consortium and individual tax clearance certificates for the members of the Joint Venture/Consortium are not acceptable.</p>
C.3.1	Respond to requests from the tenderer	The Employer will respond to requests received for clarification up to 7 (seven) working days before the tender closing time.
C.3.4	Opening of tender submissions	Tenders will be opened immediately after the closing time for tenders
C.3.11.1	Evaluating of tender offers	<p>This tender will be evaluated according to the following four stages</p> <p>Stage 1 Administrative compliance</p>

		Compulsory Returnable Documentation (Submission of these are compulsory)	Submitted (YES or NO)	Checklist (Guide for Bidder and the Bid Evaluation Committee)
		a) To enable The City to verify the bidder's tax compliance status, the bidder must provide; <ul style="list-style-type: none"> • A copy of their Tax Clearance Certificate (TCS); or • Indicate their tax compliance status PIN. 		TCS must be in the same business name as the bidding company. TCS must be valid. Tax status must be compliant before the award.
		b) A copy of their Central Supplier Database (CSD) registration; or indicate their Master Registration Number / CSD Number;		CSD must be valid. Tax status must be compliant before the award.
		c) Confirmation that the bidding company's rates and taxes are up to date: Original or copy of Municipal Account Statement of the Bidder (bidding company) not older than 3 months and account must not be in arrears for more than ninety (90) days; or ,signed lease agreement or In case of bidders located in informal settlement, rural areas or areas where they are not required to pay Rates and Taxes a letter from the local councillor confirming they are operating in that area		Was a Municipal Account Statement or landlord letter provided for the bidding company? The name and / or addresses of the bidder's statement correspond with CIPC document, Address on CSD or Company profile? Are all payment(s) up to date (i.e. not in arrears for more than 90 days?
		d) In addition to the above, confirmation that all the bidding company's owners / members / directors / major shareholders rates and taxes are up to date: <ul style="list-style-type: none"> • Original or copy of Municipal Account Statement of all the South African based owners / members / directors / major shareholders not older than 3 months and the account/s may not be in arrears for more than ninety (90) days; or a signed lease agreement of owners / members / directors / major shareholders or In case of bidders located in informal settlement, rural areas or areas where they are not required to pay Rates and Taxes a letter from the local councillor confirming they are residing in that area 		Was a Municipal Account Statement or landlord letter provided for the bidding company? The name and / or addresses of the bidder's statement correspond with CIPC document, Address on CSD or Company profile? Are all payment(s) up to date (i.e. not in arrears for more than 90 days?
		e) Duly Signed and completed MBD forms (MBD 1, 4, 5, 8 and 9) The person signing the bid documentation must be authorized to sign on behalf of the bidder. Where the signatory is not a Director / Member / Owner / Shareholder of the company, an official letter of authorization or delegation of authority should be submitted with the bid document. NB: Bidders must ensure that the directors, trustees, managers, principal		All documents fully completed (i.e. no blank spaces)? All documents fully signed? Signature authorized (any director / member / trustee as indicated on the CIPC document, alternatively a delegation of authority would be required? Documents completed in black ink (i.e. no "Tippex" corrections, no pencil, no other color ink, or non-

		<p>shareholders, or stakeholders of this company, declare any interest in any other related companies or business, whether or not they are bidding for this contract. <u>See Question 3.14 of MBD 4.</u> <u>Failure to declare interest will result in a disqualification</u></p>		<p>submission of the above, will be considered)?</p>
		<p>f) Financial Statements for the most recent three (3) years or financial statements from date of existence for companies less than three years old. NB: The bidder must submit signed audited annual financial statements for the most recent three years, or if established for a shorter period, submit audited annual financial statements from date of establishment. If the bidder is not required by law to prepare signed annual financial statements for auditing purposes, then the bidder must submit proof that the bidder is not required by law to prepare audited financial statements.</p>		<p>Applicable for tenders above R10m in conjunction with MBD 5) Are Audited financial statements provided (Audited financials must be signed by auditor)? Or proof that the bidder is not required by law to prepare audited financial statements.</p>
		<p>g) Joint Ventures (JV) – (Only applicable when the bidder tenders as a joint venture) Where the bidder bids as a joint venture (JV), the required or relevant documents as per (a) to (f) above must be provided for all JV parties. In addition to the above the bidder must submit a Joint Venture (JV) agreement signed by the relevant parties. NB: It is a condition of this bid that the successful bidder will continue with the same Joint Venture (JV) for the duration of the contract unless prior approval is obtained from the City.</p>		<p>If applicable. JV agreement provided? JV agreement complete and relevant? Agreement signed by all parties? All required documents as per (i.e. a to f) must be provided for all partners of the JV.</p>
		<p>h) Bidder attended a compulsory briefing session where applicable</p>		<p>A compulsory briefing register must be signed by the bidder. Bidders will be disqualified should they fail to attend compulsory briefing session</p>
		<p>i) Pricing schedule (All items must be quoted for in pricing schedule and if not, all items are quoted the bidder will be disqualified). Unless the tender is awarded per item or per section where the bidder only quoted the items or sections, they are interested in.</p>		<p>Incomplete pricing schedule results in totals being incomparable. Bidder must be disqualified. Bidder will be disqualified should they make corrections on the price schedule without attaching a signature thereto. Bidder will be disqualified should they use tippex/</p>

				correction ink, on the price schedule.
		Stage 2 Eligibility/Mandatory: Stage 3 Functionality Stage 4 Preference point system: 90/10		
		Specific goals	90/10 preference point system	Proof of specific goals to be submitted
		BB-BEE score of companies <ul style="list-style-type: none"> • Level 1 • Level 2 • Level 3 • Level 4 • Level 5 • Level 6 • Level 7 • Level 8 • Non-compliant 	<ul style="list-style-type: none"> • 4 Points • 3.5 Points • 3 Points • 2.5 Points • 2 Points • 1.5 Points • 1 Point • 0.5 Points 0 Points 	Valid Certified copy of BBEE Sworn Affidavit for B-BBEE qualifying small enterprise or Exempt Micro Enterprises or CIPC BBEE certificate.
		EME and/ or QSE	1 Point	Valid Sworn affidavit for B-BBEE qualifying small enterprise or Exempt Micro Enterprises or CIPC BBEE certificate
		At least 51% of Women-owned companies	1 Point	Certified copy of Identity Document/s and proof of ownership (Sworn affidavit for qualifying small enterprise or Exempt Micro Enterprises, CIPC registration or any other ownership)
		At least 51% owned companies by People with disability	1 Point	Medical Certificate with doctor's details (Practice Number, Physical Address, and contact numbers) and proof of ownership (Sworn affidavit for B-BBEE qualifying small enterprise or Exempt Micro Enterprises, CIPC registration or any other ownership)
		At least 51% owned companies by Youth	1 Point	Certified copy of Identity Document/s and proof of ownership (Sworn affidavit for B-BBEE qualifying small enterprise or Exempt Micro Enterprises, CIPC registration or any other ownership)
		Local Economic Participation <ul style="list-style-type: none"> • City of Tshwane • Gauteng • National 	2 Points 1 Point 1 Point	Municipal Account statement/Lease agreement.

		<p>The CIDB Standard Conditions of Tender are based on a procurement system that satisfies the following system requirements:</p> <table border="1"> <thead> <tr> <th>Requirement</th> <th>Qualitative interpretation of goal</th> </tr> </thead> <tbody> <tr> <td>Fair</td> <td>The process of offer and acceptance is conducted impartially without bias, providing simultaneous and timely access to participating parties to the same information.</td> </tr> <tr> <td>Equitable</td> <td>Terms and conditions for performing the work do not unfairly prejudice the interests of the parties.</td> </tr> <tr> <td>Transparent</td> <td>The only grounds for not awarding a contract to a tenderer who satisfies all requirements are restrictions from doing business with the employer, lack of capability or capacity, legal impediments and conflicts of interest.</td> </tr> <tr> <td>Competitive</td> <td>The system provides for appropriate levels of competition to ensure cost effective and best value outcomes.</td> </tr> <tr> <td>Cost effective</td> <td>The processes, procedures and methods are standardized with sufficient flexibility to attain best value outcomes in respect of quality, timing and price, and least resources to effectively manage and control procurement processes.</td> </tr> </tbody> </table>			Requirement	Qualitative interpretation of goal	Fair	The process of offer and acceptance is conducted impartially without bias, providing simultaneous and timely access to participating parties to the same information.	Equitable	Terms and conditions for performing the work do not unfairly prejudice the interests of the parties.	Transparent	The only grounds for not awarding a contract to a tenderer who satisfies all requirements are restrictions from doing business with the employer, lack of capability or capacity, legal impediments and conflicts of interest.	Competitive	The system provides for appropriate levels of competition to ensure cost effective and best value outcomes.	Cost effective	The processes, procedures and methods are standardized with sufficient flexibility to attain best value outcomes in respect of quality, timing and price, and least resources to effectively manage and control procurement processes.
Requirement	Qualitative interpretation of goal															
Fair	The process of offer and acceptance is conducted impartially without bias, providing simultaneous and timely access to participating parties to the same information.															
Equitable	Terms and conditions for performing the work do not unfairly prejudice the interests of the parties.															
Transparent	The only grounds for not awarding a contract to a tenderer who satisfies all requirements are restrictions from doing business with the employer, lack of capability or capacity, legal impediments and conflicts of interest.															
Competitive	The system provides for appropriate levels of competition to ensure cost effective and best value outcomes.															
Cost effective	The processes, procedures and methods are standardized with sufficient flexibility to attain best value outcomes in respect of quality, timing and price, and least resources to effectively manage and control procurement processes.															
C.3.11.7	Scoring Financial	<p>POINTS AWARDED FOR PRICE</p> <p>THE 80/20 OR 90/10 PREFERENCE POINT SYSTEMS A maximum of 80 or 90 points is allocated for price on the following basis:</p> <p style="text-align: center;">80/20 or 90/10</p> $P_s = 80 \left(1 - \frac{P_t - P_{min}}{P_{min}} \right) \quad \text{or} \quad P_s = 90 \left(1 - \frac{P_t - P_{min}}{P_{min}} \right)$ <p>Where Ps = Points scored for price of tender under consideration Pt = Price of tender under consideration Pmin = Price of lowest acceptable tender</p>														
C.3.11.8	Scoring Preference	<p>Scoring preference</p> <p>Specific goals</p> <table border="1"> <thead> <tr> <th>Specific goals</th> <th>90/10 preference point system</th> <th>Proof of specific goals to be submitted</th> </tr> </thead> <tbody> <tr> <td> BB-BEE score of companies <ul style="list-style-type: none"> • Level 1 • Level 2 • Level 3 • Level 4 • Level 5 • Level 6 • Level 7 • Level 8 • Non-compliant </td> <td> <ul style="list-style-type: none"> • 4 Points • 3.5 Points • 3 Points • 2.5 Points • 2 Points • 1.5 Points • 1 Point • 0.5 Points 0 Points </td> <td>Valid Certified copy of BBEE Sworn Affidavit for B-BBEE qualifying small enterprise or Exempt Micro Enterprises or CIPC BBEE certificate.</td> </tr> <tr> <td>EME and/ or QSE</td> <td>1 Point</td> <td>Valid Sworn affidavit for B-BBEE qualifying small enterprise or Exempt Micro Enterprises or CIPC BBEE certificate</td> </tr> <tr> <td>At least 51% of Women-owned</td> <td>1 Point</td> <td>Certified copy of Identity</td> </tr> </tbody> </table>			Specific goals	90/10 preference point system	Proof of specific goals to be submitted	BB-BEE score of companies <ul style="list-style-type: none"> • Level 1 • Level 2 • Level 3 • Level 4 • Level 5 • Level 6 • Level 7 • Level 8 • Non-compliant 	<ul style="list-style-type: none"> • 4 Points • 3.5 Points • 3 Points • 2.5 Points • 2 Points • 1.5 Points • 1 Point • 0.5 Points 0 Points 	Valid Certified copy of BBEE Sworn Affidavit for B-BBEE qualifying small enterprise or Exempt Micro Enterprises or CIPC BBEE certificate.	EME and/ or QSE	1 Point	Valid Sworn affidavit for B-BBEE qualifying small enterprise or Exempt Micro Enterprises or CIPC BBEE certificate	At least 51% of Women-owned	1 Point	Certified copy of Identity
Specific goals	90/10 preference point system	Proof of specific goals to be submitted														
BB-BEE score of companies <ul style="list-style-type: none"> • Level 1 • Level 2 • Level 3 • Level 4 • Level 5 • Level 6 • Level 7 • Level 8 • Non-compliant 	<ul style="list-style-type: none"> • 4 Points • 3.5 Points • 3 Points • 2.5 Points • 2 Points • 1.5 Points • 1 Point • 0.5 Points 0 Points 	Valid Certified copy of BBEE Sworn Affidavit for B-BBEE qualifying small enterprise or Exempt Micro Enterprises or CIPC BBEE certificate.														
EME and/ or QSE	1 Point	Valid Sworn affidavit for B-BBEE qualifying small enterprise or Exempt Micro Enterprises or CIPC BBEE certificate														
At least 51% of Women-owned	1 Point	Certified copy of Identity														

		companies		Document/s and proof of ownership (Sworn affidavit for B-BBEE qualifying small enterprise or Exempt Micro Enterprises, CIPC registration or any other proof of ownership)	
		At least 51% owned companies by People with disability	1 Point	Medical Certificate with doctor's details (Practice Number, Physical Address, and contact numbers) and proof of ownership (Sworn affidavit for B-BBEE qualifying small enterprise or Exempt Micro Enterprises, CIPC registration or any other proof of ownership)	
		At least 51% owned companies by Youth	1 Point	Certified copy of Identity Document/s and proof of ownership (Sworn affidavit for B-BBEE qualifying small enterprise or Exempt Micro Enterprises, CIPC registration or any other proof of ownership)	
		Local Economic Participation <ul style="list-style-type: none"> • City of Tshwane • Gauteng • National 	2 Points 1 Point 1 Point	Municipal Account statement/Lease agreement.	
C.3.13	Acceptance of Tender Offer	Tender offers will only be accepted if: <ol style="list-style-type: none"> a.) the tenderer is able to produce a valid Tax Compliance Status PIN in the name of the tendering entity as issued by the South African Revenue Services (SARS).; b.) the tenderer submits a letter of intent from an approved Bank/insurance company undertaking to provide the Performance Bond to the format included in Section C1.3 of this procurement document; c.) the tenderer is registered with the Construction Industry Development Board in an appropriate contractor grading designation. d.) the tenderer is not in arrears for more than 3 months with municipal rates and taxes and municipal service charges; c.) the tenderer or any of its directors is not listed on the Register of Tender Defaulters in terms of the Prevention and Combating of Corrupt Activities Act of 2004 as a person prohibited from doing business with the public sector; f.) the tenderer has not: <ol style="list-style-type: none"> i) abused the Employer's Supply Chain Management System; or ii) failed to perform on any previous contract and has been given a written notice to this effect. g.) the tenderer has completed the Compulsory Enterprise Questionnaire and there are no conflicts of interest which may impact on the tenderer's ability to perform the contract in the best interests of the employer or potentially compromise the tender process and persons in the employ of the state are permitted to submit tenders or participate in the contract; h.) the tenderer is registered and in good standing with the compensation fund or with a licensed compensation insurer; d.) the employer is reasonably satisfied that the tenderer has in terms of the 			

		<p>Construction</p> <p>e.) Regulations, 2014, issued in terms of the Occupational Health and Safety Act, 1993, the</p> <p>f.) necessary competencies and resources to carry out the work safely.</p>
--	--	--

T1.3 STANDARD CONDITIONS OF TENDER

TABLE OF CONTENTS

- C.1 General
 - C.1.1 Actions
 - C.1.2 Tender Documents
 - C.1.3 Interpretation
 - C.1.4 Communication and employer's agent
 - C.1.5 The employer's right to accept or reject any tender offer
 - C.1.6 Procurement procedures
 - C.1.6.1 General
 - C.1.6.2 Competitive negotiation procedure
 - C.1.6.3 Proposal procedure using the two stage-system

- C.2 Tenderer's obligations
 - C.2.1 Eligibility
 - C.2.2 Cost of tendering
 - C.2.3 Check documents
 - C.2.4 Confidentiality and copyright of documents
 - C.2.5 Reference documents
 - C.2.6 Acknowledge addenda
 - C.2.7 Clarification meeting
 - C.2.8 Seek clarification
 - C.2.9 Insurance
 - C.2.10 Pricing the tender offer
 - C.2.11 Alterations to documents
 - C.2.12 Alternative tender offers
 - C.2.13 Submitting a tender offer
 - C.2.13 Information and data to be completed in all respects
 - C.2.14 Closing time
 - C.2.15 Tender offer validity
 - C.2.16 Clarification of tender offer after submission
 - C.2.17 Provide other material
 - C.2.18 Inspections, test and analysis
 - C.2.19 Submit securities, bonds, policies, etc
 - C.2.20 Check final draft
 - C.2.21 Return of other tender documents
 - C.2.22 Certificates

- C.3 The employer's undertakings
 - C.3.1 Respond to requests from the tenderer
 - C.3.2 Issue addenda
 - C.3.3 Return late tender offers
 - C.3.4 Opening of tender submissions
 - C.3.5 Two-envelope system
 - C.3.6 Non-disclosure
 - C.3.7 Grounds for rejection and disqualification
 - C.3.8 Test for responsiveness
 - C.3.9 Arithmetical errors, omissions and discrepancies
 - C.3.10 Clarification of a tender offer
 - C.3.11 Evaluation of tender offers
 - C.3.11.1 General
 - C.3.11.2 Method 1: Financial offer
 - C.3.11.3 Method 2: Financial offer and preference
 - C.3.11.4 Method 3: Financial offer and quality

- C.3.11.5 Method 4: Financial offer, quality and preference
- C.3.11.6 Decimal places
- C.3.11.7 Scoring financial offers
- C.3.11.8 Scoring preferences
- C.3.11.9 Scoring quality
- C.3.12 Insurance provided by the employer
- C.3.13 Acceptance of tender offer
- C.3.14 Prepare contract documents
- C.3.15 Complete adjudicator's contract
- C.3.16 Notice to unsuccessful tenderers
- C.3.17 Provide copies of the contracts
- C3.18 Provide written reasons for actions taken

C.1 General

C.1.1 Actions

C.1.1.1 The employer and each tenderer submitting a tender offer shall comply with these conditions of tender. In their dealings with each other, they shall discharge their duties and obligations as set out in C.2 and C.3, timeously and with integrity, and behave equitably, honestly and transparently, comply with all legal obligations and not engage in anticompetitive practices.

C.1.1.2 The employer and the tenderer and all their agents and employees involved in the tender process shall avoid conflicts of interest and where a conflict of interest is perceived or known, declare any such conflict of interest, indicating the nature of such conflict. Tenderers shall declare any potential conflict of interest in their tender submissions. Employees, agents and advisors of the employer shall declare any conflict of interest to whoever is responsible for overseeing the procurement process at the start of any deliberations relating to the procurement process or as soon as they become aware of such conflict and abstain from any decisions where such conflict exists or recuse themselves from the procurement process, as appropriate.

Note: *1) A conflict of interest may arise due to a conflict of roles which might provide an incentive for improper acts in some circumstances. A conflict of interest can create an appearance of impropriety that can undermine confidence in the ability of that person to act properly in his or her position even if no improper acts result.*

2) Conflicts of interest in respect of those engaged in the procurement process include direct, indirect or family interests in the tender or outcome of the procurement process and any personal bias, inclination, obligation, allegiance or loyalty which would in any way affect any decisions taken.

C.1.1.3 The employer shall not seek and a tenderer shall not submit a tender without having a firm intention and the capacity to proceed with the contract.

C1.2 Tender Documents

The documents issued by the employer for the purpose of a tender offer are listed in the tender data.

C.1.3 Interpretation

C.1.3.1 The tender data and additional requirements contained in the tender schedules that are included in the returnable documents are deemed to be part of these conditions of tender.

C.1.3.2 These conditions of tender, the tender data and tender schedules which are required for tender evaluation purposes, shall form part of any contract arising from the invitation to tender.

C.1.3.3 For the purposes of these conditions of tender, the following definitions apply:

- a) **conflict of interest** means any situation in which:
 - i) someone in a position of trust has competing professional or personal interests which make it difficult to fulfil his or her duties impartially;
 - ii) an individual or tenderer is in a position to exploit a professional or official capacity in some way for their personal or corporate benefit; or
 - iii) incompatibility or contradictory interests exist between an employee and the tenderer who employs that employee.
- b) **comparative offer** means the price after the factors of a non-firm price and all unconditional discounts it can be utilised to have been taken into consideration;
- c) **corrupt practice** means the offering, giving, receiving or soliciting of anything of value to influence the action of the employer or his staff or agents in the tender process;
- d) **fraudulent practice** means the misrepresentation of the facts in order to influence the tender process or the award of a contract arising from a tender offer to the detriment of the employer, including collusive practices intended to establish prices at artificial levels;

C.1.4 Communication and employer's agent

Each communication between the employer and a tenderer shall be to or from the employer's agent only, and in a form that can be readily read, copied and recorded. Communications shall be in the English language. The employer shall not take any responsibility for non-receipt of communications from or by a tenderer. The name and contact details of the employer's agent are stated in the tender data.

C.1.5 Cancellation and Re-Invitation of Tenders

C.1.5.1 An employer may, prior to the award of the tender, cancel a tender if-

- a) due to changed circumstances, there is no longer a need for the engineering and construction works specified in the invitation;
- b) funds are no longer available to cover the total envisaged expenditure; or
- c) no acceptable tenders are received.
- d) there is a material irregularity in the tender process.

C.1.5.2 The decision to cancel a tender invitation must be published in the same manner in which the original tender invitation was advertised.

C.1.5.3 An employer may only with the prior approval of the relevant treasury cancel a tender invitation for the second time.

C.1.6 Procurement procedures

C.1.6.1 General

Unless otherwise stated in the tender data, a contract will, subject to C.3.13, be concluded with the tenderer who in terms of C.3.11 is the highest ranked or the tenderer scoring the highest number of tender evaluation points, as relevant, based on the tender submissions that are received at the closing time for tenders.

C.1.6.2 Competitive negotiation procedure

C.1.6.2.1 Where the tender data require that the competitive negotiation procedure is to be followed, tenderers shall submit tender offers in response to the proposed contract in the first round of submissions. Notwithstanding the requirements of C.3.4, the employer shall announce only the names of the tenderers who make a submission.

The requirements of C.8 relating to the material deviations or qualifications which affect the competitive position of tenderers shall not apply.

C.1.6.2.2 All responsive tenderers or at least a minimum of not less than three responsive tenderers that are highest ranked in terms of the evaluation criteria stated in the tender data shall be invited to enter into competitive negotiations based on the principle of equal treatment, keeping confidential the proposed solutions and associated information.

C.1.6.2.3 At the conclusion of each round of negotiations, tenderers shall be invited by the employer to revise their tender offer based on the same evaluation criteria, with or without adjusted weightings. Tenderers shall be advised when they are to submit their best and final offer.

C.1.6.2.4 The contract shall be awarded in accordance with the provisions of C.3.11 and C.3.13 after tenderers have been requested to submit their best and final offer.

C.1.6.3 Proposal procedure using the two stage-system

C.1.6.3.1 Option 1

Tenderers shall in the first stage submit technical proposals and, if required, cost parameters around which a contract may be negotiated. The employer shall evaluate each responsive submission in terms of the method of evaluation stated in the tender data, and in the second stage negotiate a contract with the tenderer scoring the highest number of evaluation points and award the contract in terms of these conditions of tender.

C.1.6.3.2 Option 2

C.1.6.3.2.1 Tenderers shall submit in the first stage only technical proposals. The employer shall invite all responsive tenderers to submit tender offers in the second stage, following the issuing of procurement documents.

C.1.6.3.2.2 The employer shall evaluate tenders received during the second stage in terms of the method of evaluation stated in the tender data, and award the contract in terms of these conditions of tender.

C.2 Tenderer's obligations

C.2.1 Eligibility

C.2.1.1 Submit a tender offer only if the tenderer satisfies the criteria stated in the tender data and the tenderer, or any of his principals, is not under any restriction to do business with employer.

C.2.1.2 Notify the employer of any proposed material change in the capabilities or formation of the tendering entity (or both) or any other criteria which formed part of the qualifying requirements used by the employer as the basis in a prior process to invite the tenderer to submit a tender offer and obtain the employer's written approval to do so prior to the closing time for tenders.

C.2.2 Cost of tendering

C.2.2.1 Accept that, unless otherwise stated in the tender data, the employer will not compensate the tenderer for any costs incurred in the preparation and submission of a tender offer, including the costs of any testing necessary to demonstrate that aspects of the offer comply with requirements.

C.2.2.2 The cost of the tender documents charged by the employer shall be limited to the actual cost incurred by the employer for printing the documents. Employers must attempt to make available the tender documents on its website so as not to incur any costs pertaining to the printing of the tender documents.

C.2.3 Check documents

Check the tender documents on receipt for completeness and notify the employer of any discrepancy or omission.

C.2.4 Confidentiality and copyright of documents

Treat as confidential all matters arising in connection with the tender. Use and copy the documents issued by the employer only for the purpose of preparing and submitting a tender offer in response to the invitation.

C.2.5 Reference documents

Obtain, as necessary for submitting a tender offer, copies of the latest versions of standards, specifications, conditions of contract and other publications, which are not attached but which are

incorporated into the tender documents by reference.

C.2.6 Acknowledge addenda

Acknowledge receipt of addenda to the tender documents, which the employer may issue, and if necessary, apply for an extension to the closing time stated in the tender data, in order to take the addenda into account.

C.2.7 Clarification meeting

Attend, where required, a clarification meeting at which tenderers may familiarize themselves with aspects of the proposed work, services or supply and raise questions. Details of the meeting(s) are stated in the tender data.

C.2.8 Seek clarification

Request clarification of the tender documents, if necessary, by notifying the employer at least five (5) working days before the closing time stated in the tender data.

C.2.9 Insurance

Be aware that the extent of insurance to be provided by the employer (if any) might not be for the full cover required in terms of the conditions of contract identified in the contract data. The tenderer is advised to seek qualified advice regarding insurance.

C.2.10 Pricing the tender offer

C.2.10.1 Include in the rates, prices, and the tendered total of the prices (if any) all duties, taxes except Value Added Tax (VAT), and other levies payable by the successful tenderer, such duties, taxes and levies being those applicable fourteen (14) days before the closing time stated in the tender data.

C.2.10.2 Show VAT payable by the employer separately as an addition to the tendered total of the prices.

C.2.10.3 Provide rates and prices that are fixed for the duration of the contract and not subject to adjustment except as provided for in the conditions of contract identified in the contract data.

C.2.10.4 State the rates and prices in Rand unless instructed otherwise in the tender data. The conditions of contract identified in the contract data may provide for part payment in other currencies.

C.2.11 Alterations to documents

Do not make any alterations or additions to the tender documents, except to comply with instructions issued by the employer, or necessary to correct errors made by the tenderer. All signatories to the tender offer shall initial all such alterations.

C.2.12 Alternative tender offers

C.2.12.1 Unless otherwise stated in the tender data, submit alternative tender offers only if a main tender offer, strictly in accordance with all the requirements of the tender documents, is also submitted as well as a schedule that compares the requirements of the tender documents with the alternative requirements that are proposed.

C.2.12.2 Accept that an alternative tender offer must be based only on the criteria stated in the tender data or criteria otherwise acceptable to the employer.

C.2.12.3 An alternative tender offer must only be considered if the main tender offer is the winning tender.

C.2.13 Submitting a tender offer

C.2.13.1 Submit one tender offer only, either as a single tendering entity or as a member in a joint venture to provide the whole of the works identified in the contract data and described in the scope of works, unless stated otherwise in the tender data.

C.2.13.2 Return all returnable documents to the employer after completing them in their entirety, either electronically (if they were issued in electronic format) or by writing legibly in non-erasable ink.

C.2.13.3 Submit the parts of the tender offer communicated on paper as an original plus the number of copies stated in the tender data, with an English translation of any documentation in a language other than English, and the parts communicated electronically in the same format as they were issued by the employer.

C.2.13.4 Sign the original and all copies of the tender offer where required in terms of the tender data.

The employer will hold all authorized signatories liable on behalf of the tenderer. Signatories for tenderers proposing to contract as joint ventures shall state which of the signatories is the lead partner whom the employer shall hold liable for the purpose of the tender offer.

C.2.13.5 Seal the original and each copy of the tender offer as separate packages marking the packages as "ORIGINAL" and "COPY". Each package shall state on the outside the employer's address and identification details stated in the tender data, as well as the tenderer's name and contact address.

C.2.13.6 Where a two-envelope system is required in terms of the tender data, place and seal the returnable documents listed in the tender data in an envelope marked "financial proposal" and place the remaining returnable documents in an envelope marked "technical proposal". Each envelope shall state on the outside the employer's address and identification details stated in the tender data, as well as the tenderer's name and contact address.

C.2.13.7 Seal the original tender offer and copy packages together in an outer package that states on the outside only the employer's address and identification details as stated in the tender data.

C.2.13.8 Accept that the employer will not assume any responsibility for the misplacement or premature opening of the tender offer if the outer package is not sealed and marked as stated.

C.2.13.9 Accept that tender offers submitted by facsimile or e-mail will be rejected by the employer, unless stated otherwise in the tender data.

C.2.14 Information and data to be completed in all respects

Accept that tender offers, which do not provide all the data or information requested completely and in the form required, may be regarded by the employer as non-responsive.

C.2.15 Closing time

C.2.15.1 Ensure that the employer receives the tender offer at the address specified in the tender data not later than the closing time stated in the tender data. Accept that proof of posting shall not be accepted as proof of delivery.

C.2.15.2 Accept that, if the employer extends the closing time stated in the tender data for any reason, the requirements of these conditions of tender apply equally to the extended deadline.

C.2.16 Tender offer validity

C.2.16.1 Hold the tender offer(s) valid for acceptance by the employer at any time during the validity period stated in the tender data after the closing time stated in the tender data.

C.2.16.2 If requested by the employer, consider extending the validity period stated in the tender data for an agreed additional period with or without any conditions attached to such extension.

C.2.16.3 Accept that a tender submission that has been submitted to the employer may only be withdrawn or substituted by giving the employer's agent written notice before the closing time for tenders that a tender is to be withdrawn or substituted.

If the validity period stated in C.2.16 lapses before the employer evaluating tender, the contractor reserves the right to review the price based on Consumer Price Index (CPI).

C.2.16.4 Where a tender submission is to be substituted, a tenderer must submit a substitute tender in accordance with the requirements of C.2.13 with the packages clearly marked as "SUBSTITUTE".

C.2.17 Clarification of tender offer after submission

Provide clarification of a tender offer in response to a request to do so from the employer during the evaluation of tender offers. This may include providing a breakdown of rates or prices and correction of arithmetical errors by the adjustment of certain rates or item prices (or both). No change in the competitive position of tenderers or substance of the tender offer is sought, offered, or permitted.

Note: *Sub-clause C.2.17 does not preclude the negotiation of the final terms of the contract with a preferred tenderer following a competitive selection process, should the Employer elect to do so.*

C.2.18 Provide other material

C.2.18.1 Provide, on request by the employer, any other material that has a bearing on the tender offer, the tenderer's commercial position (including notarized joint venture agreements), preferencing arrangements, or samples of materials, considered necessary by the employer for the purpose of a full and fair risk assessment.

Should the tenderer not provide the material, or a satisfactory reason as to why it cannot be provided, by the time for submission stated in the employer's request, the employer may regard the tender offer as non-responsive.

C.2.18.2 Dispose of samples of materials provided for evaluation by the employer, where required.

C.2.19 Inspections, tests and analysis

Provide access during working hours to premises for inspections, tests and analysis as provided for in the tender data.

C.2.20 Submit securities, bonds and policies

If requested, submit for the employer's acceptance before formation of the contract, all securities, bonds, guarantees, policies and certificates of insurance required in terms of the conditions of contract identified in the contract data.

C.2.21 Check final draft

Check the final draft of the contract provided by the employer within the time available for the employer to issue the contract.

C.2.22 Return of other tender documents

If so, instructed by the employer, return all retained tender documents within twenty-eight (28) days after the expiry of the validity period stated in the tender data.

C.2.23 Certificates

Include in the tender submission or provide the employer with any certificates as stated in the tender data.

C.3 The employer's undertakings

C.3.1 Respond to requests from the tenderer

C.3.1.1 Unless otherwise stated in the tender Data, respond to a request for clarification received up to five (5) working days before the tender closing time stated in the Tender Data and notify all tenderers who collected tender documents.

C.3.1.2 Consider any request to make a material change in the capabilities or formation of the tendering entity (or both) or any other criteria which formed part of the qualifying requirements used to prequalify a tenderer to submit a tender offer in terms of a previous procurement process and deny any such request if as a consequence:

- a) an individual firm, or a joint venture as a whole, or any individual member of the joint venture fails to meet any of the collective or individual qualifying requirements;
- b) the new partners to a joint venture were not prequalified in the first instance, either as individual firms or as another joint venture; or
- c) in the opinion of the Employer, acceptance of the material change would compromise the outcome of the prequalification process.

C.3.2 Issue Addenda

If necessary, issue addenda that may amend or amplify the tender documents to each tenderer during the period from the date that tender documents are available until three (3) working days before the tender closing time stated in the Tender Data. If, as a result a tenderer applies for an extension to the closing time stated in the Tender Data, the Employer may grant such extension and, shall then notify all tenderers who collected tender documents.

C.3.3 Return late tender offers

Return tender offers received after the closing time stated in the Tender Data, unopened, (unless it is necessary to open a tender submission to obtain a forwarding address), to the tenderer concerned.

C.3.4 Opening of tender submissions

C.3.4.1 Unless the two-envelope system is to be followed, open valid tender submissions in the presence of tenderers' agents who choose to attend at the time and place stated in the tender data. Tender submissions for which acceptable reasons for withdrawal have been submitted will not be opened.

C.3.4.2 Announce at the meeting held immediately after the opening of tender submissions, at a venue indicated in the tender data, the name of each tenderer whose tender offer is opened and, where applicable, the total of his prices, number of points claimed for its BBEE status level and time for completion for the main tender offer only.

C.3.4.3 Make available the record outlined in C.3.4.2 to all interested persons upon request.

C.3.5 Two-envelope system

C.3.5.1 Where stated in the tender data that a two-envelope system is to be followed, open only the technical proposal of valid tenders in the presence of tenderers' agents who choose to attend at the time and place stated in the tender data and announce the name of each tenderer whose technical proposal is opened.

C.3.5.2 Evaluate functionality of the technical proposals offered by tenderers, then advise tenderers who remain in contention for the award of the contract of the time and place when the financial proposals will be opened. Open only the financial proposals of tenderers, who score in the functionality evaluation more than the minimum number of points for functionality stated in the tender data, and announce the score obtained for the technical proposals and the total price and any points claimed on BBBEE status level. Return unopened financial proposals to tenderers whose technical proposals failed to achieve the minimum number of points for functionality.

C.3.6 Non-disclosure

Not disclose to tenderers, or to any other person not officially concerned with such processes, information relating to the evaluation and comparison of tender offers, the final evaluation price and recommendations for the award of a contract, until after the award of the contract to the successful tenderer.

C.3.7 Grounds for rejection and disqualification

Determine whether there has been any effort by a tenderer to influence the processing of tender offers and instantly disqualify a tenderer (and his tender offer) if it is established that he engaged in corrupt or fraudulent practices.

C.3.8 Test for responsiveness

C.3.8.1 Determine, after opening and before detailed evaluation, whether each tender offer properly received:

- a) complies with the requirements of these Conditions of Tender,
- b) has been properly and fully completed and signed, and
- c) is responsive to the other requirements of the tender documents.

C.3.8.2 A responsive tender is one that conforms to all the terms, conditions, and specifications of the tender documents without material deviation or qualification. A material deviation or qualification is one which, in the Employer's opinion, would:

- a) detrimentally affect the scope, quality, or performance of the works, services or supply identified in the Scope of Work,
- b) significantly change the Employer's or the tenderer's risks and responsibilities under the contract, or
- c) affect the competitive position of other tenderers presenting responsive tenders, if it were to be rectified.

Reject a non-responsive tender offer, and not allow it to be subsequently made responsive by correction or withdrawal of the non-conforming deviation or reservation.

C.3.9 Arithmetical errors, omissions and discrepancies

C.3.9.1 Check responsive tenders for discrepancies between amounts in words and amounts in figures. Where there is a discrepancy between the amounts in figures and the amount in words, the amount in words shall govern.

- C.3.9.2 Check the highest ranked tender or tenderer with the highest number of tender evaluation points after the evaluation of tender offers in accordance with C.3.11 for:
- a) the gross misplacement of the decimal point in any unit rate;
 - b) omissions made in completing the pricing schedule or bills of quantities; or
 - c) arithmetic errors in:
 - i) line item totals resulting from the product of a unit rate and a quantity in bills of quantities or schedules of prices; or
 - ii) the summation of the prices.
- C.3.9.3 Notify the tenderer of all errors or omissions that are identified in the tender offer and either confirm the tender offer as tendered or accept the corrected total of prices.
- C.3.9.4 Where the tenderer elects to confirm the tender offer as tendered, correct the errors as follows:
- a) If bills of quantities or pricing schedules apply and there is an error in the line item total resulting from the product of the unit rate and the quantity, the line item total shall govern and the rate shall be corrected. Where there is an obviously gross misplacement of the decimal point in the unit rate, the line item total as quoted shall govern, and the unit rate shall be corrected.
 - b) Where there is an error in the total of the prices either as a result of other corrections required by this checking process or in the tenderer's addition of prices, the total of the prices shall govern and the tenderer will be asked to revise selected item prices (and their rates if bills of quantities apply) to achieve the tendered total of the prices.

C.3.10 Clarification of tender offer

Obtain clarification from a tenderer on any matter that could give rise to ambiguity in a contract arising from the tender offer.

C.3.11 Evaluation of tenderoffers

The Standard Conditions of Tender standardize the procurement processes, methods and procedures from the time that tenders are invited to the time that a contract is awarded. They are generic in nature and are made project specific through choices that are made in developing the Tender Data associated with a specific project.

Conditions of tender are by definition the document that establishes a tenderer's obligations in submitting a tender and the employer's undertakings in soliciting and evaluating tender offers.

Such conditions establish the rules from the time a tender is advertised to the time that a contract is awarded and require employers to conduct the process of offer and acceptance in terms of a set of standard procedures.

The CIDB Standard Conditions of Tender are based on a procurement system that satisfies the following system requirements:	
Requirement	Qualitative interpretation of goal
Fair	The process of offer and acceptance is conducted impartially without bias, providing simultaneous and timely access to participating parties to the same information.
Equitable	Terms and conditions for performing the work do not unfairly prejudice the interests of the parties.
Transparent	The only grounds for not awarding a contract to a tenderer who satisfies all requirements are restrictions from doing business with the employer, lack of capability or capacity, legal impediments and conflicts of interest.
Competitive	The system provides for appropriate levels of competition to ensure cost effective and

	best value outcomes.
Cost effective	The processes, procedures and methods are standardized with sufficient flexibility to attain best value outcomes in respect of quality, timing and price, and least resources to effectively manage and control procurement processes.

The activities associated with evaluating tender offers are as follows:

- a) Open and record tender offers received
- b) Determine whether or not tender offers are complete
- c) Determine whether or not tender offers are responsive
- d) Evaluate tender offers
- e) Determine if there are any grounds for disqualification
- f) Determine acceptability of preferred tenderer
- g) Prepare a tender evaluation report
- h) Confirm the recommendation contained in the tender evaluation report

C.3.11.1 General

The employer must appoint an evaluation panel of not less than three persons conversant with the proposed scope of works to evaluate each responsive tender offer using the tender evaluation methods and associated evaluation criteria and weightings that are specified in the tender data.

C.3.12 Insurance provided by the employer

If requested by the proposed successful tenderer, submit for the tenderer's information the policies and / or certificates of insurance which the conditions of contract identified in the contract data, require the employer to provide.

C.3.13 Acceptance of tender offer

Accept the tender offer; if in the opinion of the employer, it does not present any risk and only if the tenderer:

- a) is not under restrictions, or has principals who are under restrictions, preventing participating in the employer's procurement;
- b) can, as necessary and in relation to the proposed contract, demonstrate that he or she possesses the professional and technical qualifications, professional and technical competence, financial resources, equipment and other physical facilities, managerial capability, reliability, experience and reputation, expertise and the personnel, to perform the contract;
- c) has the legal capacity to enter into the contract;
- d) is not; insolvent, in receivership, under Business Rescue as provided for in chapter 6 of the Companies Act No. 2008, bankrupt or being wound up, has his/her affairs administered by a court or a judicial officer, has suspended his/her business activities or is subject to legal proceedings in respect of any of the foregoing;
- e) complies with the legal requirements, if any, stated in the tender data; and
- f) is able, in the opinion of the employer, to perform the contract free of conflicts of interest.

C.3.14 Prepare contract documents

C.3.14.1 If necessary, revise documents that shall form part of the contract and that were issued by the employer as part of the tender documents to take account of:

- a) addenda issued during the tender period,
- b) inclusion of some of the returnable documents and
- c) other revisions agreed between the employer and the successful tenderer.

C.3.14.2 Complete the schedule of deviations attached to the form of offer and acceptance, if any.

C.3.15 Complete adjudicator's contract

Unless alternative arrangements have been agreed or otherwise provided for in the contract, arrange for both parties to complete formalities for appointing the selected adjudicator at the same time as the main contract is signed.

C.3.16 Registration of the award

An employer must, within twenty-one (21) working days from the date on which a contractor's offer to perform a construction works contract is accepted in writing by the employer, register and publish the award on the CIDB Register of Projects.

C.3.17 Provide copies of the contracts

Provide to the successful tenderer the number of copies stated in the Tender Data of the signed copy of the contract as soon as possible after completion and signing of the form of offer and acceptance.

C.3.18 Provide written reasons for actions taken

Provide upon request written reasons to tenderers for any action that is taken in applying these conditions of tender but withhold information which is not in the public interest to be divulged, which is considered to prejudice the legitimate commercial interests of tenderers or might prejudice fair competition between tenderers.

PART T2: RETURNABLE DOCUMENTS

TABLE OF CONTENTS

T2.1 LIST OF RETURNABLE DOCUMENTS	2
T2.2 RETURNABLE SCHEDULES	5

T2.1 LIST OF RETURNABLE DOCUMENTS

RD.A MANDATORY RETURNABLE DOCUMENTS

Note: *Failure to submit, fully complete and sign the applicable documents and submit all required attachments will result in the tender offer being disqualified from further consideration*

Document Name	Reference	Confirmation of Document Included (Tenders may use this column to confirm documents have been completed and included in the tender)
Compulsory Enterprise Questionnaire	Form RD.A.1	
MBD 4: Declaration of interest in tender of persons in service of state	Form RD.A.2	
MBD 8: Declaration of tenderer's past supply chain management practises	Form RD.A.3	
MBD 9: Certificate of independent tender determination	Form RD.A.4	
Certificate of authority of signatory	Form RD.A.5	
Certificate of authority of signatory for joint ventures and consortia	Form RD.A.6	

RD.B RETURNABLE DOCUMENTS REQUIRED FOR PREFERENTIAL PROCUREMENT EVALUATION PURPOSES

Note: *Failure to submit, fully complete and sign the applicable documents and submit all required attachments will result in the tender offer being awarded 0 (zero) preference points*

Document Name	Reference	Confirmation of Document Included (Tenders may use this column to confirm documents have been completed, signed and included in the tender)
MBD 6.1: Preference Points Claim Form in terms of the Preferential Procurement Regulations 2022	Form RD.B.1	
Valid B-BBEE Status Level of Contributor Certificate	Form RD.B.2	
B-BBEE Exempted Micro Enterprise – Sworn Affidavit	Form RD.B.3	
Promotion of local enterprises (Local Economic Participation)	Form RD.B.4	
Certified copy of Identity Document/s proof of ownership (Sworn affidavit for B-BBEE qualifying small enterprise or Exempt Micro Enterprises, CIPC registration or any other proof of ownership)	Form RD.B.5	
Medical Certificate with doctor's details (Practice Number, Physical Address and contact numbers) proof of ownership (Sworn affidavit for B-BBEE qualifying small enterprise or Exempt Micro Enterprises, CIPC registration or any other proof of ownership)	Form RD.B.6	

RD.C ADDITIONAL RETURNABLE DOCUMENTS REQUIRED FOR TENDER EVALUATION PURPOSES

Note: Failure to submit, fully complete and sign the applicable documents and submit all required attachments will result in the Tenderer having to submit same upon request within 7 days and if not complied with, will result to the tender offer being disqualified from further consideration.

Document Name	Reference	Confirmation of Document Included (Tenders may use this column to confirm documents have been completed and included in the tender)
Proof of registration on CSD with National Treasury	RD.C.1	
MBD 5: Declaration for procurement above R10 million (all applicable taxes included)	RD.C.2	
Proof of Registration with CIDB	RD.C.3	
Compliance with OHSA (Act 85 of 1993)	RD.C.4	
Record of services provided to organs of state	RD.C.5	
Schedule of plant and equipment	RD.C.6	
Status of concern submitting tender	RD.C.8	
Classification of business	RD.C.9	
Letter of intent to provide a performance bond	RD.C.10	

RD.D RETURNABLE DOCUMENTS REQUIRED FOR QUALITY EVALUATION PURPOSES

Note: Failure to submit the applicable documents will result in the Tenderer receiving a 0 (zero) score for the applicable evaluation schedule.

Document Name	Refer to Returnable Documents	Maximum Points	Confirmation of Document Included (Tenders may use this column to confirm documents have been completed and included in the tender) Yes / No
Schedule of Tenderer's experience	RD.D.3	51	
Quality management procedures and systems	RD.D.5	9	
Key Personnel	RD.D.8	40	
Curriculum vitae of key personnel	RD.D.9		
Schedule of materials	RD.D.10		
Registration as an electrical contractor	RD.D.11		
Lighting simulations	RD.D.12		
Luminaire and LED Module lifespan	RD.D.13		
Life cycle cost summary table	RD.D.14		
Summary Of Tenderer's Experience Score	RD.D.15		

RD.E OTHER DOCUMENTS THAT WILL FORM PART OF THE CONTRACT

Note: *Failure to submit, fully complete and sign the applicable documents and submit all required attachments will result in the tender offer being disqualified from further consideration*

Document Name	Reference	Confirmation of Document Included (Tenders may use this column to confirm documents have been completed and included in the tender) Yes / No
Record of addenda to tender documents	RD.E.1	
Form of Offer	Section C1.1	
Contract Data (Data provided by the contractor)	Section C1.2	
Pricing schedule	Section C2.2	

T2.2 RETURNABLE SCHEDULES

Table of Contents

PART T1:	TENDER PROCEDURES	1
PART T2:	RETURNABLE DOCUMENTS.....	1
FORM RD.A.1	COMPULSORY ENTERPRISE QUESTIONNAIRE.....	7
FORM RD.A.2	MBD 4: DECLARATION OF INTEREST.....	9
FORM RD.A.3	MBD 8: DECLARATION OF TENDER'S PAST SUPPLY CHAIN MANAGEMENT PRACTISES	12
FORM RD.A.4	MBD 9: CERTIFICATION OF INDEPENDENT TENDER DETERMINATION .	14
FORM RD.A.5	CERTIFICATE OF AUTHORITY OF SIGNATORY	17
FORM RD.A.6	CERTIFICATE OF AUTHORITY OF SIGNATORY FOR JOINT VENTURES AND CONSORTIA	18
RDB.1 MBD 6.1	PREFERENCE POINTS CLAIM FORM IN TERMS OF THE PREFERENTIAL PROCUREMENT REGULATIONS 2022.....	19
FORM RD.B.2	VALID B-BBEE STATUS LEVEL OF CONTRIBUTOR CERTIFICATE	24
FORM RD.B.3	B-BBEE EXEMPTED MICRO ENTERPRISE – SWORN AFFIDAVIT	25
FORM RD.C.12	PROMOTION OF LOCAL ENTERPRISES.....	26
FORM RD.B.5	At least 51% Women owned companies and At least 51% owned companies by Youth.....	27
FORM RD.B.6	At least 51% owned companies by People with disability.....	28
FORM RD.C.1	PROOF OF REGISTRATION ON CSD WITH NATIONAL TREASURY	29
FORM RD.C.2	MBD 5: DECLARATION FOR PROCUREMENT ABOVE R10 MILLION	30
FORM RD.C.3	PROOF OF REGISTRATION WITH THE CIDB.....	31
FORM RD.C.4	COMPLIANCE WITH OHSA (ACT 85 OF 1993)	32
FORM RD.C.5	RECORD OF SERVICES PROVIDED TO ORGANS OF STATE.....	33
FORM RD.C.6	SCHEDULE OF PLANT AND EQUIPMENT.....	34
FORM RD.C.8	STATUS OF CONCERN SUBMITTING TENDER.....	36
FORM RD.C.9	CLASSIFICATION OF BUSINESS.....	38
FORM RD.C.10	LETTER OF INTENT TO PROVIDE A PERFORMANCE BOND.....	40
FORM RD.D.3	SCHEDULE OF TENDERERS EXPERIENCE	41
FORM RD.D.5	QUALITY MANAGEMENT PROCEDURES AND SYSTEMS	42
FORM RD.D.8	KEY PERSONNEL	43
FORM RD.D.9.1	CURRICULUM VITAE FOR PROFESSIONALLY REGISTERED PERSONNEL 44	
FORM RD.D.9.2	CURRICULUM VITAE OF KEY PERSONNEL	45
FORM RD.D.10	SCHEDULE OF MATERIALS	46
FORM RD.D.11	REGISTRATION AS AND ELECTRICAL CONTRACTOR.....	48
FORM RD.D.12	LIGHTING SIMULATIONS.....	49
FORM RD.D.13	LUMINAIRE AND LED MODULE LIFESPAN.....	53
FORM RD.D.14 (A)	LIFE CYCLE COST SUMMARY TABLE.....	54

FORM RD.D.14 (B) ENERGY AND MAINTENANCE LIFE CYCLE COST TABLES	55
FORM RD.D.15 SUMMARY OF TENDERER'S EXPERIENCE SCORE	56
FORM RD.E.1 RECORD OF ADDENDA TO TENDER DOCUMENTS	57
C1.1 FORM OF AGREEMENT	0
C1.2.4 DATA PROVIDED BY THE CONTRACTOR	14

FORM RD.A.1 COMPULSORY ENTERPRISE QUESTIONNAIRE

The following particulars must be furnished. In the case of a joint venture, separate enterprise questionnaires in respect of each partner must be completed and submitted.

Section 1: Name of Enterprise:

Section 2: VAT registration number, if any:

Section 3: CIDB registration number, if any:

Section 4: CSD number:

Section 5: Particulars of sole proprietors and partners in partnerships:

Name*	Identity Number*	Personal Income Tax Number*

** Complete only if sole proprietor or partnership and attach separate page if more than 3 partners*

Section 6: Particulars of companies and close corporations

Company registration number:

Close corporation number:

Tax reference number:

Section 7: MBD4 issued by National Treasury must be completed for each tender and be attached as a tender requirement.

Section 9: MBD8 issued by National Treasury must be completed for each tender and be attached as a tender requirement.

Section 10: MBD9 issued by National Treasury must be completed for each tender and be attached as a tender requirement.

The undersigned, who warrants that he / she is duly authorised to do so on behalf of the enterprise:

- i) authorizes the employer to verify the tenderers tax clearance status from the South African Revenue Services that it is in order;
- ii) confirms that the neither the name of the enterprise or the name of any partner, manager, director or other person, who wholly or partly exercises or may exercise, control over the enterprise appears on the Register of Tender Defaulters established in terms of the Prevention and Combating of Corrupt Activities Act of 2004;
- iii) confirms that no partner, member, director or other person, who wholly or partly exercises, or may exercise, control over the enterprise appears, has within the last five years been convicted of fraud or corruption;
- iv) confirms that I / we are not associated, linked or involved with any other tendering entities submitting tender offers and have no other relationship with any of the tenderers or those responsible for compiling the scope of work that could cause or be interpreted as a conflict of interest; and
- v) confirms that the contents of this questionnaire are within my personal knowledge and are to the best of my belief both true and correct.

Signed:

Date:

Name:		Position	
<i>Enterprise Name:</i>			

FORM RD.A.2 MBD 4: DECLARATION OF INTEREST

1. No bid will be accepted from persons in the service of the state¹.
2. Any person, having a kinship with persons in the service of the state, including a blood relationship, may make an offer or offers in terms of this invitation to bid. In view of possible allegations of favouritism, should the resulting bid, or part thereof, be awarded to persons connected with or related to persons in service of the state, it is required that the bidder or their authorised representative declare their position in relation to the evaluating/adjudicating authority.

3. In order to give effect to the above, the following questionnaire must be completed and submitted with the bid.

3.1 Full name of bidder or his/her representative:

3.2 Identity Number:

3.3 Position occupied in Company:
(Director, trustee, shareholder²)

3.4 Company Registration Number:

3.5 Tax Reference Number:

3.6 VAT Registration Number:

3.7 The names of all directors / trustees / shareholders members, their individual identity numbers and state employee numbers must be indicated in paragraph 4 below.

3.8 Are you presently in the service of the state?

YES	NO
-----	----

¹ MSCM Regulations: "in the service of the state" means to be –

- (a) a member of –
 - (i) any municipal council;
 - (ii) any provincial legislature; or
 - (iii) the national Assembly or the national Council of provinces;
- (b) a member of the board of directors of any municipal entity;
- (c) an official of any municipality or municipal entity;
- (d) an employee of any national or provincial department, national or provincial public entity or constitutional institution within the meaning of the Public Finance Management Act, 1999 (Act No.1 of 1999);
- (e) a member of the accounting authority of any national or provincial public entity; or
- (f) an employee of Parliament or a provincial legislature

² Shareholder" means a person who owns shares in the company and is actively involved in the management of the company or business and exercises control over the company.

If yes, furnish particulars _____

3.9 Have you been in the service of the state for the past twelve months?

YES	NO
-----	----

If yes, furnish particulars _____

3.10 Do you have any relationship (family, friend, other) with persons in the service of the state and who may be involved with the evaluation and or adjudication of this bid?

YES	NO
-----	----

If yes, furnish particulars _____

3.11 Are you, aware of any relationship (family, friend, other) between any other bidder and any persons in the service of the state who may be involved with the evaluation and or adjudication of this bid?

YES	NO
-----	----

If yes, furnish particulars _____

3.12 Are any of the company's directors, trustees, managers, principle shareholders or stakeholders in service of the state?

YES	NO
-----	----

If yes, furnish particulars _____

3.13 Are any spouse, child or parent of the company's directors trustees, managers, principle shareholders or stakeholders in service of the state?

YES	NO
-----	----

If yes, furnish particulars _____

3.14 Do you or any of the directors, trustees, managers, principal shareholders, or stakeholders of this company have any interest in any other related companies or business whether or not they are bidding for this contract?

YES	NO
-----	----

If yes, furnish particulars _____

FORM RD.A.3 MBD 8: DECLARATION OF TENDER'S PAST SUPPLY CHAIN MANAGEMENT PRACTISES

1. This municipal tender document must form part of all tenders invited.
2. It serves as a declaration to be used by municipalities and municipal entities in ensuring that when goods and services are being procured, all reasonable steps are taken to combat the abuse of the supply chain management system.
3. The tender of any tenderer may be rejected if that tenderer, or any of its directors have:
 - a. abused the municipality's/municipal entity's supply management system or committed any improper conduct in relation to such system;
 - b. been convicted for fraud or corruption during the past five years;
 - c. wilfully neglected, reneged on or failed to comply with any government, Municipal or other public sector contract during the past five years; or
 - d. been listed in the Register for Tender Defaulters in terms of Section 29 of the Prevention and Combating of Corrupt Activities Act, 2004 (Act 12 of 2004).
4. In order to give effect to the above, the following questionnaire must be completed and submitted with the tender:

Item	Question	Response	
4.1	Is the tenderer, any of its directors listed on the National Treasurer's database as a company or persons prohibited from doing business with the public sector? (Companies for persons who are listed on this database were informed in writing of this restriction by the National Treasury after the <i>audi alteram partem</i> rule was applied) If so, furnish particulars:	YES	NO
4.2	Is the tenderer or any of its directors listed on the Register for Tender Defaulters in terms of Section 29 of the Prevention and Combating of Corrupt Activities Act, 2004 (Act 12 of 2004)? (The Register for Tender Defaulters can be accessed on the National Treasury's website (www.treasury.gov.za) by clicking on its link at the bottom of the home page.) If so, furnish particulars:	YES	NO
4.3	Was the tenderer or any of its directors convicted by a court of law (including a court of law outside the Republic of South Africa) for fraud or corruption during the past five years? If so, furnish particulars:	YES	NO

Item	Question	Response	
4.4	Does the tenderer or any of its directors owe any municipal rates and taxes or municipal charges to the municipality/municipal entity, or to any other municipality/municipal entity, that is in arrears for more than three months? If so, furnish particulars:	YES	NO
4.5	Was any contract between the tenderer and the municipality/municipal entity or any other organ of state terminated during the past five years on account of failure to perform on or comply with the contract? If so, furnish particulars:	YES	NO

The undersigned, who warrants that he / she is duly authorised to do so on behalf of the enterprise, confirms that the contents of this schedule are within my personal knowledge and are to the best of my belief both true and correct.

I accept that, in addition to cancellation of a contract, action may be taken against me should this declaration prove to be false.

Person authorized to sign the tender:

Full name (in BLOCK letters): _____

Signature: _____

Date: _____

FORM RD.A.4 MBD 9: CERTIFICATION OF INDEPENDENT TENDER DETERMINATION

1. This Municipal Bidding Document (MBD) must form part of all bids ³invited.
2. Section 4 (1) (b) (iii) of the Competition Act No. 89 of 1998, as amended, prohibits an agreement between, or concerted practice by, firms, or a decision by an association of firms, if it is between parties in a horizontal relationship and if it involves collusive tendering (or bid rigging⁴). Collusive tendering is a *per se* prohibition meaning that it cannot be justified under any grounds.
3. Municipal Supply Regulation 38 (1) prescribes that a supply chain management policy must provide measures for the combating of abuse of the supply chain management system, and must enable the accounting officer, among others, to:
 - a. Take all reasonable steps to prevent such abuse;
 - b. Reject the tender of any tenderer if that tenderer or any of its directors has abused the supply chain management system of the municipality or municipal entity or has committed any improper conduct in relation to such system; and
 - c. Cancel a contract awarded to a person if the person committed any corrupt or fraudulent act during the tendering process or the execution of the contract.
4. This will serve as a certificate of declaration that would be used by institutions to ensure that, when tenders are considered, reasonable steps are taken to prevent any form of tender-rigging.
5. In order to give effect to the above, the attached Certificate of Tender Determination must be completed and submitted with the tender.

³ Includes price quotations, advertised competitive bids, limited bids and proposals.

⁴ Bid rigging (or collusive bidding) occurs when businesses, that would otherwise be expected to compete, secretly conspire to raise prices or lower the quality of goods and / or services for purchasers who wish to acquire goods and / or services through a bidding process. Bid rigging is, therefore, an agreement between competitors not to compete.

CERTIFICATE OF INDEPENDENT TENDER DETERMINATION

I, the undersigned, in submitting the accompanying tender:

CONTRACT: RTD 04 2023/24 IRPTN PROJECT:
UPGRADING OF IRPTN LINE 3 INTERIM OPERATIONS: PRINCE'S PARK AND BUS STOPS/BAYS
ALONG WF NKOMO STREET

in response to the invitation for the tender made by

City of Tshwane Metropolitan Municipality

do hereby make the following statement that I certify to be true and complete in every respect:

I certify, on behalf of

_____ that:

(Name of tenderer)

1. I have read and understand the contents of this certificate;
2. I understand that the accompanying tender will be disqualified if this certificate is found not to be true and complete in every aspect;
3. I am authorised by the tenderer to sign this certificate, and to submit the accompanying tender, on behalf of the tenderer;
4. Each person whose signature appears on the accompanying tender has been authorised by the tenderer to determine the terms of, and to sign, the tender, on behalf of the tenderer;
5. For the purposes of this Certificate and the accompanying tender, I understand that the word "competitor" shall include any individual or organization, other than the tenderer, whether or not affiliated with the tenderer who:
 - a. Has been requested to submit a tender in response to this tender invitation, based on their qualifications, abilities or experience; and
 - b. Could potentially submit a tender in response to this tender invitation, based on their qualifications, abilities or experience; and provides the same goods and services as the tenderer and/or is in the same line of business as the tenderer.
6. The tenderer has arrived at the accompanying tender independently form, and without consultation, communication, agreement or arrangement with any competitor. However, communication between partners in a joint venture or consortium⁵ will not be construed as collusive tendering.
7. In particular, without limiting the generality of paragraphs 6 above, there has been no consultation, communication, agreement or arrangement with any competitor regarding:
 - a. Prices;
 - b. Geographical area where product of services will be rendered (market allocation);
 - c. Methods, factors or formulas used to calculate prices;
 - d. The intention or decision to submit or not to submit, a tender;
 - e. The submission of a tender which does not meet the specifications and conditions of the tender; or
 - f. Tendering with the intention not to win the tender.

⁵ Joint venture or consortium means an association of persons for the purpose of combining their expertise, property, capital, efforts, skill and knowledge in an activity for the execution of a contract.

8. In addition, there have been no consultations, communications, agreements or arrangement with any competitor regarding the quality, quantity, specifications and conditions or delivery particulars of the products or services to which this tender invitation relates.
9. The terms of the accompanying tender have not been, and will not be, disclosed by the tenderer, directly or indirectly, to any competitor, prior to the date and time of the official tender opening or to the awarding of the contract.
10. I am aware that, in addition and without prejudice to any other remedy provided to combat any restrictive practises related to tenders and contracts, tenders that are suspicious will be reported to the Competition Commission for investigation and possible imposition of administrative penalties in terms of section 59 of the Competition Act No. 89 of 1998 and or may be reported to the National Prosecuting Authority (NPA) for criminal investigation and or may be restricted form conduction business with the public sector for a period not exceeding ten (10) years in terms of the Prevention and combating of Corrupt Activities Act No. 12 of 2004 or any other applicable legislation.

The undersigned, who warrants that he / she is duly authorised to do so on behalf of the enterprise, confirms that the contents of this schedule are within my personal knowledge and are to the best of my belief both true and correct.

Person authorized to sign the tender:

Full name (in BLOCK letters): _____

Signature: _____

Date: _____

FORM RD.A.5 CERTIFICATE OF AUTHORITY OF SIGNATORY

RESOLUTION of the a meeting of the *Board of Directors/Members/Partners of

(Legally correct full name and registration number, if applicable, of the enterprise)

Held at: _____ (place)

On: _____ (date)

RESOLVED that:

- The enterprise submits a tender to the Tshwane Metro Municipality in respect of the following project:

Tender Number:	RTD 04 2023/24 IRPTN
Tender Description:	UPGRADING OF IRPTN LINE 3 INTERIM OPERATIONS: PRINCE'S PARK AND BUS STOPS/BAYS ALONG WF NKOMO STREET

- *Mr/Ms: _____
 in *his/her capacity _____
 as _____

and who will sign as follow:

Proof signature	Proof signature
-----------------	-----------------

be, and is hereby authorised to sign the tender, and any and all other documents and/or correspondence in connection with and relating to the tender for the enterprise mentioned above

NAME	CAPACITY	SIGNATURE

<p>Note:</p> <ol style="list-style-type: none"> *Delete which is not applicable. IMPORTANT: This resolution <u>must</u> be signed by all the directors/members/ partners of the tendering enterprise. Should the number of directors/members/partners exceed the space available above, additional names and signatures must be supplied on a separate page. 	<p>Enterprise stamp</p>
---	-------------------------

FORM RD.A.6 CERTIFICATE OF AUTHORITY OF SIGNATORY FOR JOINT VENTURES AND CONSORTIA

*Joint venture/consortium name: _____

We, the undersigned, are submitting this tender in a *joint venture/consortium and hereby authorise *Mr/Ms _____ authorised signatory of the enterprise _____ acting in the capacity of lead partner to sign the tender, and any and all other documents and/or correspondence in connection with and relating to the tender for the *joint venture/consortium mentioned above.

Registered name of enterprise	Registration number	% of contract value	Address	Duly authorised signatory	Mark with (x) for lead partner

Note:

- *Delete which is not applicable.
- IMPORTANT: This resolution must be signed by all the parties of the joint venture/consortium and every duly authorised signatory for each party to the joint venture/consortium must complete a Form RD.C.15.
- Should the number of directors/members/partners exceed the space available above, additional names and signatures must be supplied on a separate page.

RDB.1 MBD 6.1 PREFERENCE POINTS CLAIM FORM IN TERMS OF THE PREFERENTIAL PROCUREMENT REGULATIONS 2022

This preference form must form part of all tenders invited. It contains general information and serves as a claim form for preference points for specific goals.

NB: BEFORE COMPLETING THIS FORM, TENDERERS MUST STUDY THE GENERAL CONDITIONS, DEFINITIONS AND DIRECTIVES APPLICABLE IN RESPECT OF THE TENDER AND PREFERENTIAL PROCUREMENT REGULATIONS, 2022

1. GENERAL CONDITIONS

- 1.1 The following preference point systems are applicable to invitations to tender:
- the 80/20 system for requirements with a Rand value of up to R50 000 000 (all applicable taxes included); and
 - the 90/10 system for requirements with a Rand value above R50 000 000 (all applicable taxes included).
- 1.2 To be completed by the organ of state
- a) The applicable preference point system for this tender is the 90/10 preference point system.
 - b) The 90/10 preference point system will be applicable in this tender. The lowest/ highest acceptable tender will be used to determine the accurate system once tenders are received.
- 1.3 Points for this tender (even in the case of a tender for income-generating contracts) shall be awarded for:
- (a) Price; and
 - (b) Specific Goals.

The maximum points for this tender are allocated as follows:

	POINTS
PRICE	90
SPECIFIC GOALS	10
Total points for Price and SPECIFIC GOALS	100

- 1.4 Failure on the part of a tenderer to submit proof or documentation required in terms of this tender to claim points for specific goals with the tender, will be interpreted to mean that preference points for specific goals are not claimed.
- 1.5 The organ of state reserves the right to require of a tenderer, either before a tender is adjudicated or at any time subsequently, to substantiate any claim in regard to preferences, in any manner required by the organ of state.

2. DEFINITIONS

- (a) "tender" means a written offer in the form determined by an organ of state in response to an invitation to provide goods or services through price quotations, competitive tendering process or any other method envisaged in legislation;
- (b) "price" means an amount of money tendered for goods or services, and includes all applicable taxes less all unconditional discounts;
- (c) "rand value" means the total estimated value of a contract in Rand, calculated at the time of bid invitation, and includes all applicable taxes;
- (d) "tender for income-generating contracts" means a written offer in the form determined by an organ of state in response to an invitation for the origination of income-generating contracts through any method envisaged in legislation that will result in a legal agreement between the organ of state and a third party that produces revenue for the organ of state, and includes, but is not limited to, leasing and disposal of assets and concession contracts, excluding direct sales and disposal of assets through public auctions; and
- (e) "the Act" means the Preferential Procurement Policy Framework Act, 2000 (Act No. 5 of 2000).

3. FORMULAE FOR PROCUREMENT OF GOODS AND SERVICES

3.1. POINTS AWARDED FOR PRICE

3.1.1 THE 90/10 PREFERENCE POINT SYSTEMS

A maximum of 90 points is allocated for price on the following basis:

90/10

$$P_s = 90 \left(1 - \frac{P_t - P_{min}}{P_{min}} \right)$$

Where

P_s = Points scored for price of tender under consideration
 P_t = Price of tender under consideration
 P_{min} = Price of lowest acceptable tender

4. POINTS AWARDED FOR SPECIFIC GOALS

- 4.1. In terms of Regulation 4(2); 5(2); 6(2) and 7(2) of the Preferential Procurement Regulations, preference points must be awarded for specific goals stated in the tender. For the purposes of this tender the tenderer will be allocated points based on the goals stated in table 1 below as may be supported by proof/ documentation stated in the conditions of this tender:
- 4.2. In cases where organs of state intend to use Regulation 3(2) of the Regulations, which states that, if it is unclear whether the 80/20 or 90/10 preference point system applies, an organ of state must, in the tender documents, stipulate in the case of—
 - (a) an invitation for tender for income-generating contracts, that either the 80/20 or 90/10 preference point system will apply and that the highest acceptable tender will be used to determine the applicable preference point system; or
 - (b) any other invitation for tender, that either the 80/20 or 90/10 preference point system will apply and that the lowest acceptable tender will be used to determine the applicable preference point system,then the organ of state must indicate the points allocated for specific goals for both the 90/10 and 80/20 preference point system.

Table 1: Specific goals for the tender and points claimed are indicated per the table below.
(Note to organs of state: Where either the 90/10 or 80/20 preference point system is applicable, corresponding points must also be indicated as such.
Note to tenderers: The tenderer must indicate how they claim points for each preference point system.)

The specific goals allocated points in terms of this tender	Number of points allocated (90/10 system) (To be completed by the organ of state)	Number of points claimed (90/10 system) (To be completed by the tenderer)
BB-BEE score of companies		
Level 1	4 Points	
Level 2	3.5 Points	
Level 3	3 Points	
Level 4	2.5 Points	
Level 5	2 Points	
Level 6	1.5 Points	
Level 7	1 Point	
Level 8	0.5 Points	
Non-compliant	0 Points	
EME and/or QSE	1	
At least 51% Women owned companies	1	
At least 51% owned companies by People with disability	1	
At least 51% owned companies by Youth	1	
Local Economic Participation		
City of Tshwane Participants	2	
Gauteng Participants	1	
National participants	1	

DECLARATION WITH REGARD TO COMPANY/FIRM

- 4.3. Name of company/firm.....
- 4.4. Company registration number:
- 4.5. TYPE OF COMPANY/ FIRM
 - Partnership/Joint Venture / Consortium
 - One-person business/sole propriety
 - Close corporation
 - Public Company
 - Personal Liability Company
 - (Pty) Limited
 - Non-Profit Company
 - State Owned Company

[Tick applicable box]

- 4.6. I, the undersigned, who is duly authorised to do so on behalf of the company/firm, certify that the points claimed, based on the specific goals as advised in the tender, qualifies the company/ firm for the preference(s) shown and I acknowledge that:
 - i) The information furnished is true and correct;
 - ii) The preference points claimed are in accordance with the General Conditions as indicated in paragraph 1 of this form;
 - iii) In the event of a contract being awarded as a result of points claimed as shown in paragraphs 1.4 and 4.2, the contractor may be required to furnish documentary proof to the satisfaction of the organ of state that the claims are correct;

- iv) If the specific goals have been claimed or obtained on a fraudulent basis or any of the conditions of contract have not been fulfilled, the organ of state may, in addition to any other remedy it may have –
- (a) disqualify the person from the tendering process;
 - (b) recover costs, losses or damages it has incurred or suffered as a result of that person's conduct;
 - (c) cancel the contract and claim any damages which it has suffered as a result of having to make less favourable arrangements due to such cancellation;
 - (d) recommend that the tenderer or contractor, its shareholders and directors, or only the shareholders and directors who acted on a fraudulent basis, be restricted from obtaining business from any organ of state for a period not exceeding 10 years, after the *audi alteram partem* (hear the other side) rule has been applied; and
 - (e) forward the matter for criminal prosecution, if deemed necessary.

NAME:

(in BLOCK letters)

CAPACITY:

(of authorized agent)

SIGNATURE:

(of authorized agent)

SIGNED at

on this

day of

WITNESSES:

(Full name in BLOCK letters and
signature)

1.

2.

FORM RD.B.2 VALID B-BBEE STATUS LEVEL OF CONTRIBUTOR CERTIFICATE

Submit B-BBEE Verification Certificate from a Verification Agency accredited by the South African Accreditation System (SANAS) or a Registered Auditor approved by the Independent Regulatory Board of Auditors (IRBA) or an Accounting Officer as contemplated in the Close Corporation Act (CCA).

NOTE:

- 1. Attach original copy of B-BBEE Verification Certificate to this page.**
- 2. In the case of a joint venture / consortium parties must each attach original copy of their B-BBEE Verification Certificates.**

FORM RD.C.12 PROMOTION OF LOCAL ENTERPRISES

The City of Tshwane has mandated the promotion of local enterprises. To comply with this the tenderer must provide proof of the type of business unit and whether the unit resides within the Tshwane and will be scored as follow:

90/10 preference point system applies:

	Promotion of local enterprises
No Response (score 0)	The tenderer did not respond or comply with this evaluation schedule. A score of 0 will also be awarded for any misrepresentation made in this regard,
Satisfactory (score 1)	The tenderer operates a head office or fully staffed office or his sole office outside the boundaries of Gauteng Province. (I.e. no business unit or office resides within the boundaries of Tshwane Metropolitan Municipality)
Good (score 1)	The tenderer's office resides within the boundaries of Gauteng Province. (I.e. no business unit or office resides within the boundaries of Tshwane Metropolitan Municipality)
Very good (score 2)	The tenderer's office resides within the boundaries of the Tshwane Metropolitan Municipality.

Municipal Rates & Taxes not older than three months from tender advertisement date or Valid Lease Agreement should be attached as evidence.

(If necessary the tenderer will be requested to present the office / business unit to officials of the City)

The undersigned, who warrants that he / she is duly authorized to do so on behalf of the enterprise, confirms that the contents of this schedule are within my personal knowledge and are to the best of my belief both true and correct.	
<u>Person authorized to sign the tender:</u>	
Full name (in BLOCK letters):	_____
Signature:	_____
Date:	_____

FORM RD.B.5 At least 51% Women owned companies and At least 51% owned companies by Youth

The City of Tshwane has mandate for the promotion At least 51% Women owned companies and At least 51% owned companies by youth. To comply with this the tenderer must provide Certified copy of Identity Document/s that proof that company is 51% owend by Women or youth

	promotion At least 51% Women owned companies and At least 51% owned companies by youth
No Response (score 0)	The tenderer did not respond or comply with this evaluation schedule. A score of 0 will also be awarded for any misrepresentation made in this regard,
Good (score 1)	Certified copy of Identity Document/s that proof that company is 51% owned by Women and proof of ownership (Sworn affidavit for B-BBEE qualifying small enterprise or Exempt Micro Enterprises, CIPC registration or any other proof of ownership
Good (score 1)	Certified copy of Identity Document/s that proof that company is 51% owned by youth and proof of ownership (Sworn affidavit for B-BBEE qualifying small enterprise or Exempt Micro Enterprises, CIPC registration or any other proof of ownership

(If necessary the tenderer will be requested to present the office / business unit to officials of the City)

The undersigned, who warrants that he / she is duly authorized to do so on behalf of the enterprise, confirms that the contents of this schedule are within my personal knowledge and are to the best of my belief both true and correct.	
<u>Person authorized to sign the tender:</u>	
Full name (in BLOCK letters):	_____
Signature:	_____
Date:	_____

FORM RD.B.6 At least 51% owned companies by People with disability

The City of Tshwane has mandate for the promotion of At least 51% owned companies by People with disability. To comply with this the tenderer must provide Medical Certificate with doctor's details (Practice Number, Physical Address and contact numbers that proof that company is 51% owned by People with disability

	Promotion of At least 51% owned companies by People with disability
No Response (score 0)	The tenderer did not respond or comply with this evaluation schedule. A score of 0 will also be awarded for any misrepresentation made in this regard,
Good (score 1)	Medical Certificate with doctor's details (Practice Number, Physical Address and contact numbers and proof of ownership (Sworn affidavit for B-BBEE qualifying small enterprise or Exempt Micro Enterprises, CIPC registration or any other proof of ownership

(If necessary the tenderer will be requested to present the office / business unit to officials of the City)

The undersigned, who warrants that he / she is duly authorized to do so on behalf of the enterprise, confirms that the contents of this schedule are within my personal knowledge and are to the best of my belief both true and correct.	
<u>Person authorized to sign the tender:</u>	
Full name (in BLOCK letters):	_____
Signature:	_____
Date:	_____

FORM RD.C.1 PROOF OF REGISTRATION ON CSD WITH NATIONAL TREASURY

- 1. Attach original or certified copy of CSD registration certificate to this page.**
- 2. In the case of a joint venture / consortium (excluding consulting engineering partners) the joint venture / consortium must attach original or certified copy of their CSD registration certificate to this page.**

FORM RD.C.2 MBD 5: DECLARATION FOR PROCUREMENT ABOVE R10 MILLION

1. The tenderer is required by law to prepare annual financial statements for auditing their audited annual financial statements:

- i) for the past three years; or
- ii) Since the establishment if established during the past three years.

Indicate whether these have been included in the tender:

YES	NO
-----	----

2. Does the tenderer have any undisputed commitments for municipal services towards a municipality or other service provider in respect of which payment is overdue for more than 30 days?

YES	NO
-----	----

If so, state particulars _____

3. Has any contracts been awarded to the tenderer by an organ of state during the past five years?

YES	NO
-----	----

If so, state particulars _____

4. Has there been any material non-compliance or dispute concerning the execution of such contract?

YES	NO
-----	----

If so, state particulars _____

5. Is any portion of the goods or services expected to be sourced from outside the Republic?

YES	NO
-----	----

If, so state what portion and whether any portion of payment from the municipality is expected to be transferred outside of the Republic.

The undersigned, who warrants that he / she is duly authorised to do so on behalf of the enterprise, confirms that the contents of this schedule are within my personal knowledge and are to the best of my belief both true and correct.

I accept that the state may act against me should this declaration prove to be false.

Person authorized to sign the tender:

Full name (in BLOCK letters): _____

Signature: _____

Date: _____

FORM RD.C.4 COMPLIANCE WITH OHSA (ACT 85 OF 1993)

Tenderers are required to satisfy the employer and the engineer as to their ability and available resources to comply with the above by answering the following questions and providing the relevant information required below.

(Tick applicable box)

1. Are your company familiar with the OHSA (ACT 85 of 1993) and its Regulations?	YES	NO
2. Who will prepare your company's Health and Safety Plan? Provide a copy of the person/s curriculum vitae/s or company profile.		
3. Do your company have a health and safety policy? If YES provide a copy.	YES	NO
4. How is this policy communicated to your employees? Provide supporting documentation.	YES	NO
5. Do your company keep record of safety aspects of each site where work is performed? If YES what records are kept?	YES	NO
6. Do your company conduct monthly safety meetings? If YES , who is the chairperson of the meeting, and attend these meetings?	YES	NO
7. Do your company have a safety officer in its employment, responsible for overall safety of your company? If YES , explain his duties and provide a copy of his CV	YES	NO
8. Do your company have trained first aid employees? If YES , indicate who.	YES	NO
9. Do your company have a safety induction training programme in place? If YES , provide a copy.	YES	NO
10. Does your company conduct medical surveillance for its employees?	YES	NO

The undersigned, who warrants that he / she is duly authorised to do so on behalf of the enterprise, confirms that the contents of this schedule are within my personal knowledge and are to the best of my belief both true and correct.

Person authorized to sign the tender:

Full name (in BLOCK letters): _____

Signature: _____

Date: _____

FORM RD.C.5 RECORD OF SERVICES PROVIDED TO ORGANS OF STATE

Tenderers are required to complete this record in terms of the Supply Chain Management Regulations issued in terms of the Municipal Finance Management Act of 2003.

Include only those contracts where the tenderer identified in the signature block below was directly contracted by the employer. Tenderers must not include services provided in terms of a sub-contract agreement.

Where contracts were awarded in the name of a joint venture and the tenderer formed part of that joint venture, indicate in the column entitled "Title of the contract for the service" that was in joint venture and provide the name of the joint venture that contracted with the employer. In the column for the value of the contract for the service, record the value of the portion of the contract performed (or to be performed) by the tender.

Complete the record or attach the required information in the prescribed tabulation

ALL SERVICES COMMENCED OR COMPLETED TO AN ORGAN OF STATE IN THE LAST FIVE YEARS				
	Organ of state, i.e. national or provincial department, public entity, municipality or municipal entity.	Title of contract for the service	Value of contract for service incl. VAT (Rand)	Date completed (State current if not yet completed)
1.				
2.				
3.				
4.				
5.				
6.				
7.				
8.				

(Attach additional pages if more space is required.)

The undersigned, who warrants that he / she is duly authorised to do so on behalf of the enterprise, confirms that the contents of this schedule are within my personal knowledge and are to the best of my belief both true and correct.

Person authorized to sign the tender:

Full name (in BLOCK letters): _____

Signature: _____

Date: _____

The undersigned, who warrants that he / she is duly authorized to do so on behalf of the enterprise, confirms that the contents of this schedule are within my personal knowledge and are to the best of my belief both true and correct.

Person authorized to sign the
tender:

Full name (in BLOCK letters): _____

Signature: _____

Date: _____

FORM RD.C.8 STATUS OF CONCERN SUBMITTING TENDER

1. General

State whether the tenderer is a company, a closed corporation, a partnership, a sole practitioner, a joint venture/consortium or a co-operative

Public Company	<input type="checkbox"/>
Private Company	<input type="checkbox"/>
Closed Corporation	<input type="checkbox"/>
Partnership	<input type="checkbox"/>
Sole Proprietary	<input type="checkbox"/>
Joint Venture / Consortium	<input type="checkbox"/>
Co-operative	<input type="checkbox"/>

(Mark the appropriate option)

2. Information to be provided

If the Tendering Entity is a:		Documentation to be submitted with the tender
1	<u>Closed Corporation</u> , incorporated under the Close Corporation Act, 1984, Act 69 of 1984	CIPRO CK1 or CK2 (Certified copies of the founding statement) and list of members
2	<u>Private Company</u> incorporated with share capital, under the companies Act, 1973, Act 61 of 1973 (Including Companies incorporated under Art 53 (b))	Certified copies of: a) CIPRO CM 1 - Certificate of Incorporation b) CIPRO CM 29 – Contents of Register of Directors, Auditors and Officers c) Shareholders Certificates of all Members of the Company, plus a signed statement of the Company's Auditor, certifying each Member's ownership/shareholding percentage relative to the total.
3	<u>Private Company</u> incorporated with share capital, under the companies Act, 1973, Act 61 of 1973 in which any, or all, <u>shares are held by another Closed Corporation or company with, or without, share capital.</u>	Certified copies of documents referred to in 1 and/or 2 above in respect of all such Closed Corporations and/or Companies
4	<u>Public Company</u> incorporated with share capital, under the companies Act, 1973, Act 61 of 1973 (Including Companies incorporated under Art 21)	A signed statement of the Company's Secretary confirming that the Company is a public Company.
5	<u>Sole Proprietary</u> or a <u>Partnership</u>	Certified copy of the Identity Document of: a) such Sole Proprietary, or b) Each of the Partners in the Partnership Certified copy of the Partnership agreement.
6	<u>Co-operative</u>	CIPRO CR2 - Certified copies of Company registration document.

If the Tendering Entity is a:	Documentation to be submitted with the tender
7 <u>Joint Venture / Consortium</u>	All the documents (as described above) as applicable to each partner in the joint venture / consortium as well as a certified copy of the joint venture / consortium agreement.

Note:

1. If the shares are held in trust provide a copy of the Deed of Trust (only the front page and pages listing the trustees and beneficiaries are required) as well as the Letter of Authority as issued by the Master of the Supreme Court wherein trustees have been duly appointed and authorised
2. Include a certified copy of the Certificate of Change of Name (CM9) if applicable.

3. Registered for VAT proposes in terms of the Value-Added Tax Act (89 of 1991)

Yes

No

(Make an X in the appropriate space)

REGISTRATION NO: _____

FORM RD.C.9 CLASSIFICATION OF BUSINESS

- 1. The Small Businesses are defined in the National Small Business Act, 1996 (Act 102 of 1996).
- 2. Information furnished with regard to the classification of Small businesses
 - (b.) Indicate whether the company/entity is defined as a small, medium or micro enterprise by the National Small Business Act.

YES	NO
-----	----

(Tick appropriate box)

- (c.) If the response to 2.(a.) is **YES**, the following must be completed:
 - i. Sector/sub-sector in accordance with the Standard Industrial classification:

 - ii. Size or class:

 - iii. Total full-time equivalent of paid employees:

 - iv. Total annual turnover:

 - v. Total gross asset value (fixed property excluded):

(A schedule indicating the different sectors is attached to this form.)

- (d.) The tenderer should substantiate the information provided by submitting the following documentation:
 - i. A letter from the tenderer's auditor or an affidavit from the South African Police Services confirming the correctness of the abovementioned information,
 - ii. Company profile indicating the tenderer's staff compliment, and
 - iii. 3 year financial statement or since their establishment if established during the past 3 years.

SCHEDULE OF SECTORS

SIZE OF CLASS	THE TOTAL FULL-TIME EQUIVALENT OF PAID EMPLOYEES	TOTAL TURNOVER	TOTAL GROSS ASSET VALUE (FIXED PROPERTY EXCLUDED)
AGRICULTURE			
Medium	100	R 5 mil	R 5 mil
Small	50	R 3 mil	R 3 mil
Very Small	10	R 500 000	R 500 000
Micro	5	R 200 000	R 100 000
MINING AND QUARRYING			
Medium	200	R 39 mil	R 23 mil
Small	50	R 10 mil	R 6 mil
Very Small	20	R 4 mil	R 2 mil
Micro	5	R 200 000	R 100 000
MANUFACTURING			
Medium	200	R 51 mil	R 19 mil
Small	50	R 13 mil	R 5 mil
Very Small	20	R 5 mil	R 2 mil
Micro	5	R 200 000	R 100 000
ELECTRICITY, GAS & WATER			
Medium	200	R 51 mil	R 19 mil
Small	50	R 13 mil	R 5 mil
Very Small	20	R 5.1 mil	R 1.9 mil
Micro	5	R 200 000	R 100 000
CONSTRUCTION			
Medium	200	R 26 mil	R 5 mil
Small	50	R 6 mil	R 1 mil
Very Small	20	R 3 mil	R 500 000
Micro	5	R 200 000	R 100 000
RETAIL AND MOTOR TRADE & REPAIR SERVICES			
Medium	200	R 39 mil	R 6 mil
Small	50	R 19 mil	R 3 mil
Very Small	20	R 4 mil	R 600 000
Micro	5	R 200 000	R 100 000
WHOLESALE TRADE, COMMERCIAL AGENTS AND ALLIED SERVICES			
Medium	200	R 64 mil	R 10 mil
Small	50	R 32 mil	R 5 mil
Very Small	20	R 6 mil	R 600 000
Micro	5	R 200 000	R 100 000
CATERING, ACCOMMODATION AND OTHER TRADE			
Medium	200	R 13 mil	R 3 mil
Small	50	R 6 mil	R 1 mil
Very Small	20	R 5.1 mil	R 1.9 mil
Micro	5	R 200 000	R 100 000
TRANSPORT, STORAGE & COMMUNICATIONS			
Medium	200	R 26 mil	R 6 mil
Small	50	R 13 mil	R 3 mil
Very Small	20	R 3 mil	R 600 000
Micro	5	R 200 000	R 100 000
FINANCE & BUSINESS SERVICES			
Medium	200	R 26 mil	R 5 mil
Small	50	R 13 mil	R 3 mil
Very Small	20	R 3 mil	R 500 000
Micro	5	R 200 000	R 100 000
COMMUNITY, SOCIAL AND PERSONAL SERVICES			
Medium	200	R 13 mil	R 6 mil
Small	50	R 6 mil	R 3 mil
Very Small	20	R 1 mil	R 600 000
Micro	5	R 200 000	R 100 000

FORM RD.C.10 LETTER OF INTENT TO PROVIDE A PERFORMANCE BOND

It is hereby agreed that a Performance Bond drafted **exactly** as set out in the attached examples (See Section C1.3: Form of Guarantee) will be provided by the Surety named below:

Name of Surety (Bank or Insurer) _____
Address: _____

Signed: _____

Name: _____
Capacity: _____
On behalf of Tenderer (name of tenderer) _____
Date: _____

CONFIRMED BY Surety's Authorised representative

Signature(s): _____

Name (print): _____
Capacity _____
On behalf of Surety (Bank or Insurer) _____
Date: _____

Note: Refer to the Annexure to **C1.3 Form of Guarantee** for the List of Institutions from who Contract/Deposit Guarantees will be accepted.

The undersigned, who warrants that he / she is duly authorized to do so on behalf of the enterprise, confirms that the contents of this schedule are within my personal knowledge and are to the best of my belief both true and correct.	
<u>Person authorized to sign the tender:</u>	
Full name (in BLOCK letters):	_____
Signature:	_____
Date:	_____

FORM RD.D.3 SCHEDULE OF TENDERERS EXPERIENCE

The experience of the tenderer or joint venture partners in the case of an unincorporated joint venture consortium, in similar projects, within the past 15-years, shall be evaluated. Proof of experience (Appointment letters and Completion certificates) will influence the scoring on listed projects.

NOTE: The General Conditions of Contract prohibit the sub-contracting of the whole of the Contract.

The scoring of the Tenderer's experience shall be for similar project (A road project) as follows:

Previous Project Description:

- **17 points per similar project over the value of R20 million within the last 15 years to a maximum of 51 points**
- **A similar project is a road project involving layer works and an asphalt topping**

Example:

- 1 similar project in excess of R20 million value completed = 17 points**
- 2 similar projects in excess of R20 million value for each completed = 34points**
- 3 similar projects in excess of R20 million value for each completed = 51points**

The following is a statement of similar work successfully executed by myself / ourselves:

	Employer, contact person and telephone number (Project will be rejected without current accurate contact data)	Description of contract – of similar nature for each project in excess of R20 million (17-points for each project of similar nature, scope and value – ref C3.1)	Date completed	Points/ contract <i>To be completed by Evaluator</i>
1	Employer: _____ Contact Person: _____ Tel: _____			
2	Employer: _____ Contact Person: _____ Tel: _____			
3	Employer: _____ Contact Person: _____ Tel: _____			
MAXIMUM TOTAL POINTS TENDERERS TOTAL			(51)	

FORM RD.D.5 QUALITY MANAGEMENT PROCEDURES AND SYSTEMS

Briefly describe the construction quality systems incorporated by the tenderer in his organisation, either by way of extract from the ISO 9001.2015 Certification, or extracts from Internal Quality Management Systems.

QMS needs to describe the organisations systems, in terms of a method statement exceeding 1 page long. The method statement must at least contain:

- The specific activity the method statement is for
- A description of the work
- Hours of work
- Who the assessor is
- Who has key responsibilities
- The hazards associated with the task
- The hazards associated with the site and environment
- References to other documents such as risk assessments that apply to the task
- The planned work procedure, the sequence of work and control measures
- PPE requirements
- Management arrangements
- Monitoring arrangements
- First aid and welfare arrangements
- Emergency procedures

Proof of certification will influence the scoring.

TYPE OF WORK	INTERNAL RESOURCE	EXTERNAL RESOURCE	PROCEDURE OR SYSTEM Describe Quality Management System by way of extract from the ISO – 9001-2015 Certification, or extracts from Internal Quality Management Systems	POINTS
Quality Assurance and Quality control (standards and procedures)				
ISO 9001-2015			Valid ISO Certificate to be included in respect of construction works	9
Internal system			Signed Internal Quality Management system to be included on company letter head	2
No QMS				0
MAXIMUM POINTS				(9)
TENDERERS POINTS				

The tenderer’s Quality management procedures and systems will be utilised in conjunction with those of the engineer during the construction of this project.

The BEC may request the assistance of the department in evaluating this particular criteria

FORM RD.D.8 KEY PERSONNEL

The Tenderer shall schedule the following Key Personnel who would be assigned to this Contract. The Contractor shall be contractually obliged to make these personnel available for the duration of the Contract, failing which alternative personnel of equal or higher qualification may be accepted by the employer.

POSITION	NAME	YEARS OF EXPERIENCE	NUMBER OF PROJECTS COMPLETED OF SIMILAR NATURE
Construction Manager			
Site Agent – Civil Works			
Site Agent – Electrical Works			
Occupational Health & Safety Officer			

The Tenderer shall complete a CV for each of the Key Personnel in Form RD.D.9 accompanied by the certified proof of Qualifications, Professional Registrations, and Proof of Identity for all personnel.

FORM RD.D.9.1 CURRICULUM VITAE FOR PROFESSIONALLY REGISTERED PERSONNEL

Note: This form should be completed for the Construction Manager, as listed in Form RD.D.8.

Name:	Date of birth:
Profession:	Nationality:
Qualifications:	
Professional membership, registration or license:	
Name of employer (firm):	
Current position:	Years with firm:
Certification: I, the undersigned, certify that to the best of my knowledge and belief, this data correctly describes me, my qualifications and my experience.	
_____ (Signature of person named in schedule)	_____ Date:

D.9.1.1 EMPLOYMENT RECORD (from most recent)

EMPLOYER	POSITION HELD / ROLES	DATES		YEARS EXPERIENCE	POINTS
		FROM	TO		
TOTAL POINTS					

D.9.1.2 PARTICULAR & APPROPRIATE EXPERIENCE

(A project will be rejected without current & accurate contact details)

CLIENT & CONTACT	PROJECT DESCRIPTION (ref C3.1)	DATES		VALUE >R20mil	POINTS
		FROM	TO		
TOTAL POINTS					
GRAND TOTAL POINTS (CARRIED OVER TO FORM RD.D.8)					

FORM RD.D.9.2 CURRICULUM VITAE OF KEY PERSONNEL

Note: This form should be completed for other personnel as listed in Form RD.D.8.

Name:	Date of birth:
Profession:	Nationality:
Qualifications:	
Professional membership:	
Name of employer (firm):	
Current position:	Years with firm:
Certification:	
<p>I, the undersigned, certify that to the best of my knowledge and belief, this data correctly describes me, my qualifications and my experience.</p> <p>_____</p> <p>(Signature of person named in schedule) Date: _____</p>	

D.9.2.1 EMPLOYMENT RECORD (from most recent)

EMPLOYER	POSITION HELD / ROLES	DATES		YEARS EXPERIENCE	POINTS
		FROM	TO		
TOTAL POINTS					

D.9.2.2 PARTICULAR & APPROPRIATE EXPERIENCE

(A project will be rejected without current & accurate contact details)

CLIENT & CONTACT	PROJECT DESCRIPTION (ref C3.1)	DATES		VALUE >R20mil	POINTS
		FROM	TO		
TOTAL POINTS					
GRAND TOTAL POINTS (CARRIED OVER TO FORM RD.D.8)					

FORM RD.D.10 SCHEDULE OF MATERIALS

All equipment and fittings supplied must be in accordance with the attached quality specification (of this document), suitable for the relevant supply voltage and frequency and must be approved by the Employer’s Agent.

Notes to tenderer:

1. For the purpose of clarity when using this form, a supplier is any company that supplies to a tenderer an electrical & road lighting product that it manufactures. A tenderer shall, in compliance with note 2 below, attach to this form a letter of supply from each supplier it intends using in the performance of the contract.
2. Tenderers shall append to this page the following information on a letterhead from their selected supplier:
 - the supplier’s company registration and address details; and
 - the product range available; and
 - the net base product type and content for each product; and
 - the supply price (excluding VAT but including all other obligatory taxes and levies) to the tenderer for the net product base content of each product; and
 - the date from which the supply prices apply.
3. A change of supplier may be permitted, but only upon application to the engineer with the appropriate letters of supply in compliance to Note 2 above and approval thereof.
4. Non-disclosure of reduction in supply prices shall be deemed a contractor’s deliberate action to defraud the Employer and grounds for the Employer, at its sole discretion, to terminate the contract.

Each material and equipment dealt with is stated in the list below. The rates and prices for the equipment and materials shall be furnished by the tenderer as an attachment to this Form RD. D10, which rates and prices shall not include VAT but shall include all other obligatory taxes and levies.

The schedules must only be completed insofar as the equipment and materials required for this particular contract are concerned.

If these schedules are not properly completed by the Tenderer, his bid document will be regarded as incomplete. Where types, etc. are filled in below and these do not comply with the Specification, this must be specifically pointed out by the Tenderer. Filling in of types, etc. below does not signify that they are acceptable or will be accepted, if they do not comply.

All material proposed can only be changed when prior written approval is received from the engineer.

RD.D10.1 CABLES, CONDUCTORS AND ACCESSORIES

EQUIPMENT AND MATERIAL	UNIT	RATE OR PRICE FOR BASE MONTH	DESCRIPTION AND MAKE
11kV PILC Cable			
11kV PILC Cable Joints			
11kV PILC Cable Termination			
PVC SWA ECC PVC LV Cable			
PVC SWA ECC PVC LV Cable glands			
PVC SWA ECC PVC LV Cable terminations			
PVC SWA PVC LV Cable			
PVC SWA PVC LV Cable glands			
PVC SWA PVC LV Cable terminations			
GP PVC Wire			
GP PVC Wire terminations			
Earth Conductor			
1.5m Earth Spike			

EQUIPMENT AND MATERIAL	UNIT	RATE OR PRICE FOR BASE MONTH	DESCRIPTION AND MAKE
Exo-Thermic Jointing (Cadweld)			

RD.D.10.2 MINI SUBS, DISTRIBUTION KIOSKS AND EQUIPMENT

EQUIPMENT AND MATERIAL	UNIT	RATE OR PRICE FOR BASE MONTH	DESCRIPTION AND MAKE
12 Way LV Kiosk (Vandal Resistant)			
LV Kiosk Security System			
Miniature Circuit Breakers (MCB)			
Contactors			
Photo-electric switch			
Surge Protection			

RD.D.10.3 LUMINAIRES

TYPE	UNIT	RATE OR PRICE FOR BASE MONTH	SUPPLIER AND PRODUCT TYPE
L1			
L2			
Lighting energy management and monitoring control system for entire installation			

RD.D.10.4 POLES AND HIGH MASTS

Mounting Height	UNIT	RATE OR PRICE FOR BASE MONTH	MANUFACTURER, CONSTRUCTION AND TYPE
10.50m MH pole			

RD.D.10.5 CIVIL WORKS

TYPE	UNIT	RATE OR PRICE FOR BASE MONTH	MANUFACTURER, CONSTRUCTION AND TYPE
Mast foundations			
Service sleeves			

The contractor can claim 5 points if this Form is filled in completely and satisfactorily

SIGNED BY TENDERER: _____

FORM RD.D.11 REGISTRATION AS AND ELECTRICAL CONTRACTOR

The contractor is responsible for the completion and submission of the required application forms, in respect of registration, to the particular supplying authority. A copy of the registration form must be forwarded to the engineer or its representative as soon as possible after the contract has been allocated. The electrical installation may not commence before the registration certificate and proof that the particular electrician is registered as an installation electrician has been received.

The successful Tenderer/electrical sub-contractor must be registered as an Electrical Contractor with the Electrical Contracting Board of South Africa, with the Workmen's Compensation Commissioner and the Unemployment Insurance Commissioner to qualify for this contract.

The successful Tenderer must complete the following questionnaire and submit it to the engineer before any work is commenced.

THE TENDER MAY NOT BE CONSIDERED UNLESS ALL THE NECESSARY INFORMATION HAS BEEN SUBMITTED.

Has the company been registered as an electrical contractor with the Electrical Contracting Board of South Africa?

Registration No.: _____
Date of issue : _____

YES	NO
-----	----

Has the company been registered with the:

1. Department of Manpower?
Registration No.: _____
Date of issue : _____

YES	NO
-----	----

2. The Workmen's Compensation Commissioner?
Registration No.: _____
Date of issue : _____

YES	NO
-----	----

3. The Unemployment Insurance?
Registration No.: _____
Date of issue : _____

YES	NO
-----	----

I/We certify that the above information is correct and undertake to comply with the provisions in Regulation 4(2) and 6(1) of Government Notice R2920 of 23 October 1992 promulgated under Section 35 of the Occupational Health and Safety Act, No. 85 of 1993.

SIGNATURE OF TENDERER: _____
DATE: _____
NAME OF TENDERER: _____
ADDRESS: _____

FORM RD.D.12 LIGHTING SIMULATIONS

Note to Tenderer:

Only LED luminaires will be accepted for the tender and a letter submitted indicating the origin from which luminaires are imported / manufactured from.

The lighting simulation reports submitted are to indicate compliance to SANS 10098-1 & SANS 10098-2 standards or IEC equivalent.

Lighting simulation reports are to be submitted in both hard copy and PDF format and simulations are to be submitted in DIALux Version 4.12 or later format compatibility.

The PDF simulation reports and DLX format simulations are to be submitted on the tender submission CD, under sub folder Form RD.D.12.

Failure to submit the simulation reports, DLX simulations and valid readable luminaire photometric files (IES format or equivalent) with certification letters from a reputable test facility (SABS, CSIR test facilities or similar) shall render the tender non-responsive.

Tenderers are urged to use standard spigot lengths and rake angles, where a favourable lighting design uses a fixed spigot length and fixed rake angle for all simulations, thus minimising maintenance costs.

Tenderers may be requested to submit samples of their proposed luminaires to the engineer to verify compliance of the luminaires. Tests to be conducted, but not limited to, include verifying the photometric file to the actual luminaire, IP rating, metallurgical testing, operation at rated ambient temperature, etc. The luminaires shall be returned to the tenderers by the engineer.

The Tenderer shall provide four (4) simulation reports, forming a complete set of lighting simulations, that comply with the lighting designs as described below, which as a whole is compliant to the SANS 10098-1:2007 & SANS 10098-2:2005 or equivalent IEC standards. If there is any discrepancy between Form RD.F.3 and SANS 10098-1:2007 & SANS 10098-2:2005, SANS 10098-1:2007 & SANS 10098-2:2005 will be the standard to be adhered to.

The evaluation of simulations will be based on SANS 10098-1 & SANS 10098-2 or IEC equivalent standards and evaluated with the DIALux lighting simulation software, version 4.12 or later. Simulation results shall be to two decimal point accuracy.

Should a lighting simulation out of the entire lighting simulation set be non-compliant or should there be discrepancies, it may render the tender non-responsive.

Refer to the electrical and civil drawings for cross section designs of the roads, underpass, pedestrian bridge and light mast / pole placement. Drawings included on tender CD.

The correction factor, which can be used in DIALux to alter a luminaires performance, will be set to be equal to 1 for all luminaires used in the lighting simulations.

Luminaires selected are to adhere to tender specifications.

Where the same luminaire type is used in several lighting simulations, the luminaire type must be compliant in all lighting simulations.

SIGNED BY TENDERER: _____

FORM RD.D.12 LIGHTING SIMULATIONS (Continued)

Spigot length excludes the mounting length of the luminaire.

The correct surfaces are to be used in the lighting simulations, e.g. brick paving for sidewalk and R3,q0 0.070 tarmac for carriageway surfaces, etc.

Emergency lanes (also referred to as shoulder lanes) are to be included in the lighting simulations and shall comply to the lighting levels specified for each respective simulation specified in table D12.2 below.

Colour rendering, colour temperature, is to remain constant for entire luminaire selection. It may only vary between road lighting and pedestrian sidewalk lighting. Example: using luminaires with a colour temperature of 2000K for road lighting and luminaires with a colour temperature of 4000K for pedestrian sidewalk lighting.

Each simulation is to comply with the corresponding simulation design criteria in Table D12.2 below and the corresponding simulation design criteria drawings which follow.

Luminaire maintenance factors are to be stated and calculated below and used accordingly in the simulations. The dirt depreciation factor is obtained from SANS 10098-1 Table B.1 for a burning period of 36 months before cleaning of an IP6X luminaire in an average environment installation.

TABLE Form RD.D12.1 – Luminaire Maintenance Factors

Luminaire Type	Luminaire description	Dirt Depreciation Factor	Lamp / LED Depreciation Factor for Ta = 35°C (LLMF*LSF*LMF) As per CIE 154:2003	Maintenance Factor
A	B	C	D	E = (Cx D)
L1		0.83		
L2		0.83		

TABLE Form RD.D12.2 – LIGHTING SIMULATION DESIGN CRITERIA

Simulation	Luminaire Type	Mast Spacing [m]	Mast/Pole Mounting Height (MH) [m]	Mast above Road Level [m]	Spigot Length [mm]	Maximum Rake Angle [degrees]	Offset from Edge of Road	SANS 10098 Lighting Category
1	L1		10.50m MH	0.00	500	15	0.50 m	Ln ≥ 1.50 cd/m ² UO ≥ 0,40 UL ≥ 0,70 TI ≤ 20
2	L2		6m MH	0.00	≥125	15	2.88m	Ln ≥ 1.50 cd/m ² UO ≥ 0,40 UL ≥ 0,70 TI ≤ 20
3	L1-L2		10.5m MH+8m MH	0.00		15	0.50 m	Ln ≥ 1.50 cd/m ² UO ≥ 0,40 UL ≥ 0,70 TI ≤ 20
4	L1		10.5 MH	0.00		15	2.25 m	Ln ≥ 1.50 cd/m ² UO ≥ 0,40 UL ≥ 0,70 TI ≤ 20

THE TENDERER MAY CLAIM 5 POINTS FOR COMPLETING THIS FORM CORRECTLY.

SIGNED BY TENDERER: _____

FORM RD.D.12 LIGHTING SIMULATIONS (Continued)

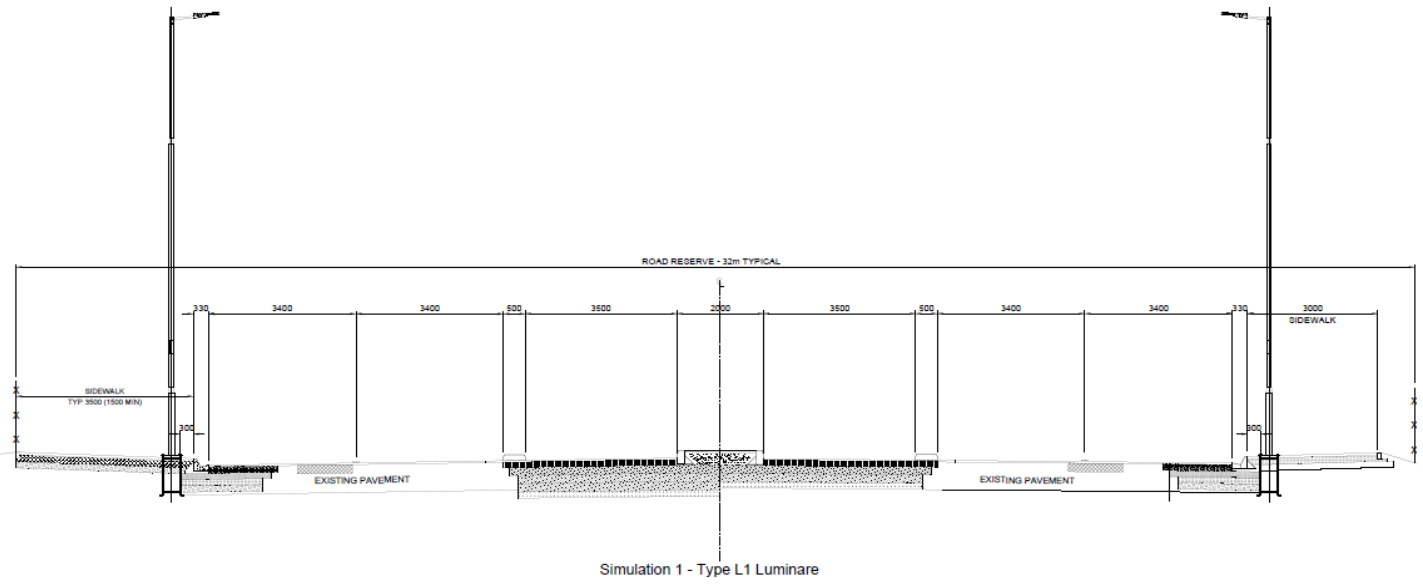

Simulation 1 - Type L1 Luminaire

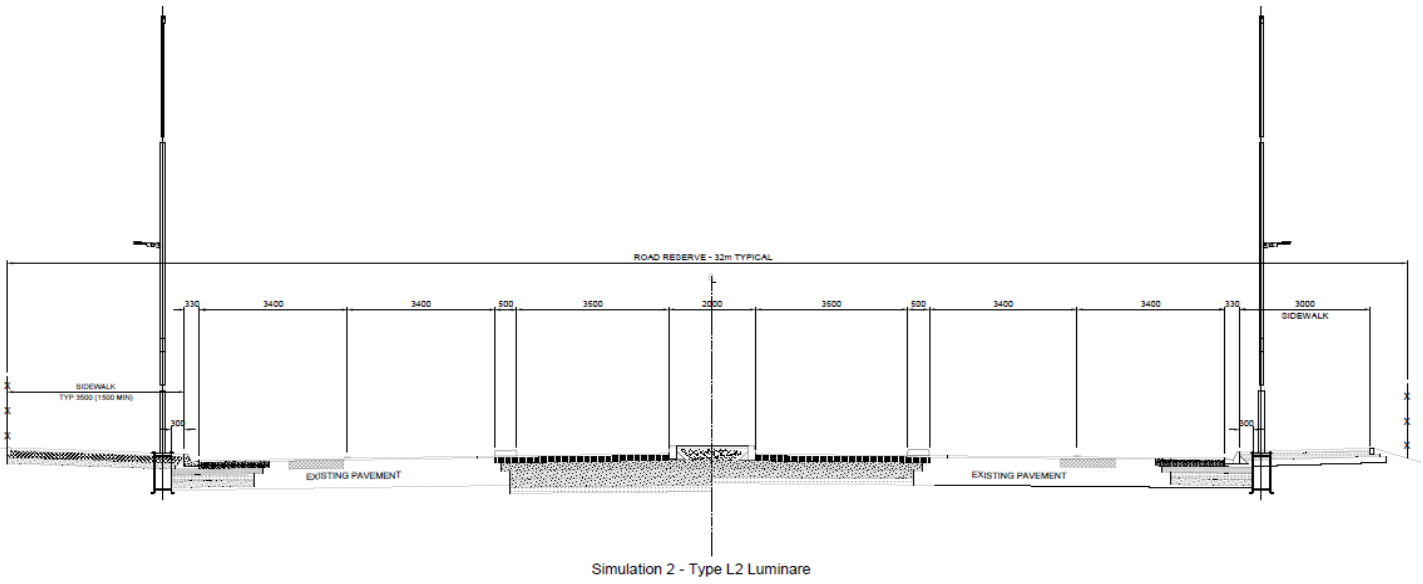

Simulation 2 - Type L2 Luminaire

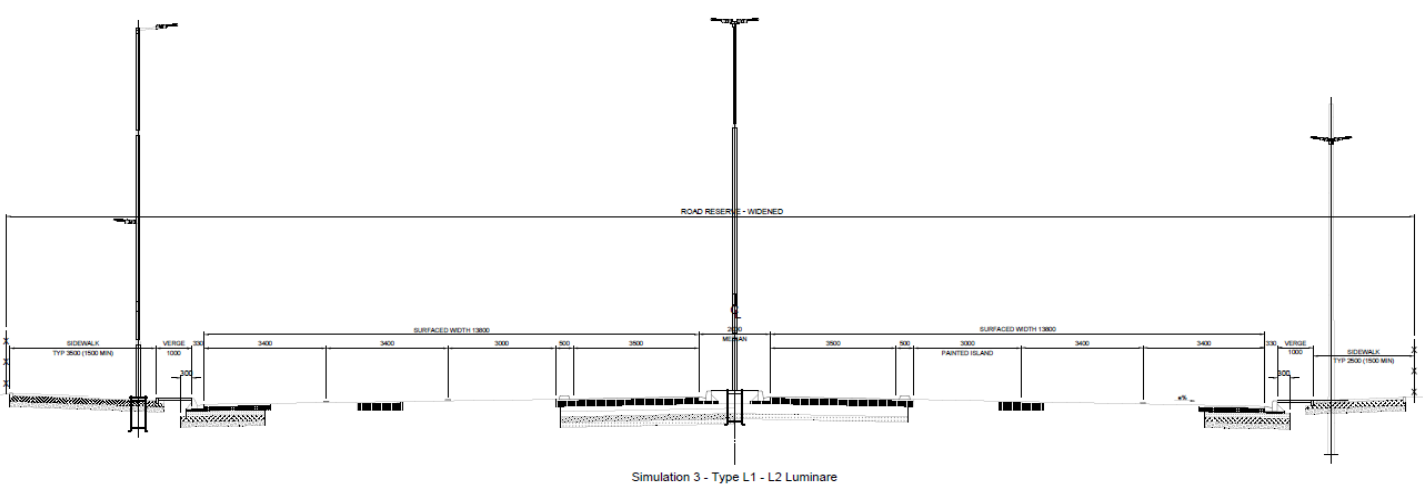

Simulation 3 - Type L1 - L2 Luminaire

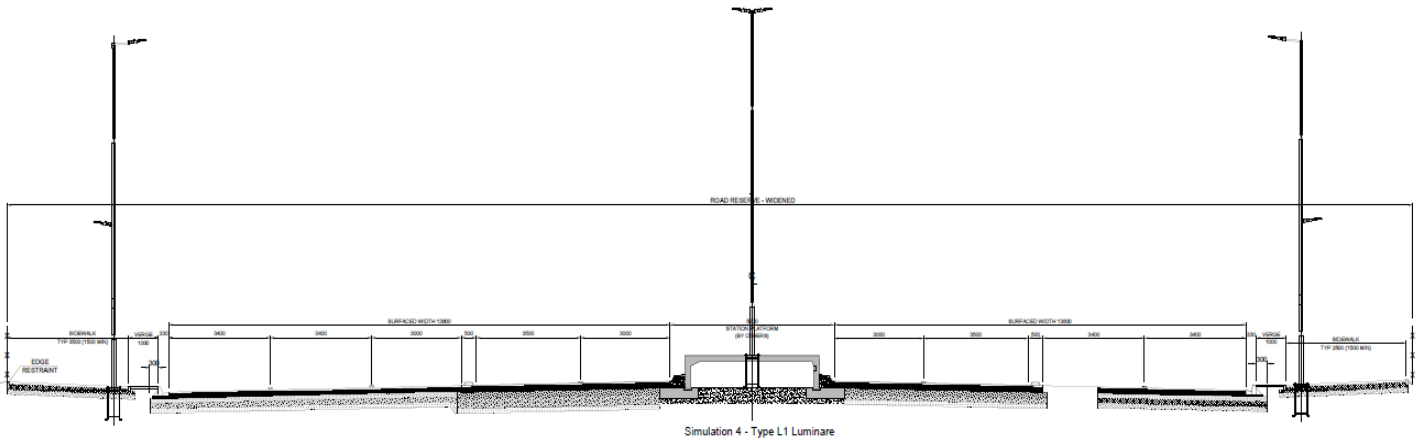

SIGNED BY TENDERER: _____

FORM RD.D.13 LUMINAIRE AND LED MODULE LIFESPAN

Note to Tenderer:

Should the information that is submitted for Form RD.D.13 be incomplete or vary from the information submitted for Form RD.D.12, particularly with respect to the simulation results, it may render the tender non-responsive.

The Tenderer must provide a letter from the supplier on the following for each type of luminaire (Failure to submit all documentation as requested below may render the tender non-responsive):

1. Specify the rated Thermal threshold of the Luminaire and Lamp / LED module
2. Luminaire and LED module lifespan in hours at rated operating ambient temperature, $T_a = 35^{\circ}\text{C}$
3. Luminaire lumen output efficiency over the lifespan at $T_a = 35^{\circ}\text{C}$
4. Lumen degradation over life span, rated for $T_a = 35^{\circ}\text{C}$
5. Control Gear and components lifespan, rated for $T_a = 35^{\circ}\text{C}$
6. Reputable Certificate (from SABS, CSIR testing facility or similar) stating that each Luminaire offered has an aluminium housing of grade LM 6 (EN1706 AC-44100) (or higher) aluminium alloy and complies with BS 1490
7. Certificate (from SABS, CSIR testing facility or similar) stating that the IP Rating and Thermal dissipation of the luminaire is unchanged by the inclusion of an energy/monitoring control gear system within the luminaire and a circuit breaker.
8. Control Gear and components lifespan due to the inclusion of the energy/monitoring control gear system.
9. Certificates from the Regulator, the body appointed by the Minister to administer compulsory specifications, are to be submitted for all luminaires proposed, in which the luminaire and all components of the luminaire adhere to the relevant Gazetted compulsory specifications. These certificates verify that any imported material adheres to Gazetted compulsory specifications and are allowed to be imported and used in the country. Failure to submit these certificates will render the tender non-responsive.

SIGNED BY TENDERER: _____

FORM RD.D.14 (A) LIFE CYCLE COST SUMMARY TABLE

Note to Tenderer:

The information provided by the suppliers, for the three tables as requested below, shall be used by the evaluation panel to determine the life cycle cost over a fifteen year period. The total for maintenance shall be added to the total for energy consumption.

These forms may be used as a determining factor in the final evaluation of the tenders. Should the best life cycle cost not be from the lowest offer (price and preference) then the difference between the lowest offer and the offer being considered shall be compared to the best savings offered in Form RD.D.15 of the tender being considered, if deemed necessary.

Maintenance and Energy Costs are to be shown for the entire lighting installation for all luminaires, without the use of an energy management and monitoring control system.

The tables below are included on the tender CD in Excel format that are to be completed, signed hard and soft copies submitted and the electronic Excel format copy completed and submitted.

(a) Life Cycle Cost Summary of entire Lighting Installation (15 year life cycle)
Life Cycle Cost Summary of Luminaires for Installation Table Form RD.D14.1

Section	Description (Note: Life Cycle based on a 15 year period)	Amount
1	SUM A – Initial Capital Cost of Luminaires for Installation	R
2	SUM B – Estimated Energy Consumption Cost for Luminaires Installation	R
3	SUM C – Estimated Maintenance Cost of Luminaires for Installation	R
	TOTAL EXCL. VAT (1+2+3)	

THE TENDERER MAY CLAIM 5 POINTS FOR COMPLETING THIS FORM CORRECTLY.

SIGNED BY TENDERER: _____

FORM RD.D.14 (B) ENERGY AND MAINTENANCE LIFE CYCLE COST TABLES

Note to Tenderer:

(b) Energy Costs (Average R/kVAh is estimated @ 10% increase per year over a 15 year life cycle)

Energy Cost Table Form RD14.2

Luminaire Type	LUMINAIRE DESCRIPTION	UNIT	QTY	RATE	AMOUNT	Luminaire Lumens [lm]	Rated Luminaire Wattage [kW]	Power Factor	Total Power per Luminaire [kVA]	Average Burning Hrs/Annum	Average R/kVAh over 15 years	Life Cycle	Energy cost per life cycle
1	2	3	4	5	6 = 4 x 5	7	8	9	10 = 8 / 9	11	12	13	14 = 4 x 10 x 11 x 12 x 13
Type 1		No		R	R					3650	R 2.46	15	R
Type 2		No		R	R					3650	R 2.46	15	R
TOTAL INITIAL LUMINAIRE INSTALLATION COST				SUM A	R	TOTAL ESTIMATED ENERGY COST OVER LIFE CYCLE PERIOD						SUM B	R

Maintenance Cost Table Form RD.D.14.3

Luminaire Type	LUMINAIRE DESCRIPTION	UNIT	QTY	Cost of Lamp / "LED Module" per Luminaire	Cost of Ballast/ Electronic Driver	Rated average Lamp / "LED Module" Life at Ta = 35°C	Rated average Ballast / Electronic Driver Life at Ta = 35°C	Average Burning Hrs/Annum	Annual Lamp / "LED Module" Replacement	Annual Ballast / Electronic Driver Replacement	Life Cycle	Maintenance cost per life cycle
1	2	3	4	5	6	7	8	9	10 = 9 / 7	11 = 9 / 8	12	13 = 12 x 3 x [10(5) + 11(6)]
Type 1		No		R	R			3650			15	R
Type 2,		No		R	R			3650			15	R
TOTAL ESTIMATED MAINTENANCE COST OVER LIFE CYCLE PERIOD											SUM C	R

THE TENDERER MAY CLAIM 5 POINTS FOR COMPLETING THIS FORM CORRECTLY.

SIGNED BY TENDERER: _____

FORM RD.D.15 SUMMARY OF TENDERER'S EXPERIENCE SCORE

CRITERIA	REFERENCE	MAX POINTS	TENDERER'S SCORE
Tenderers Experience			
Schedule of Tenderer's Experience	RD.D.3	51	
Quality Management	RD.D.5	9	
Total			
Key Personnel			
Construction Manager	RD.D.8	12	
Site Agent – Civil Works	RD.D.8	10	
Site Agent – Electrical Works	RD.D.8	10	
Occupational Health	RD.D.8	8	
Total		40	
GRAND TOTAL		100	
Min Points		70	

A minimum of **70 points** will be required to remain in the tender process.

FORM RD.E.1 RECORD OF ADDENDA TO TENDER DOCUMENTS

We confirm that the following communications received from the Employer before submission of this tender, amending or amplifying the tender documents, have been taken in account in this tender offer:

	DATE	REFERENCE	TITLE
1			
2			
3			
4			
5			
6			
7			
8			
9			
10			

The undersigned, who warrants that he / she is duly authorised to do so on behalf of the enterprise, confirms that the contents of this schedule are within my personal knowledge and are to the best of my belief both true and correct.

Person authorized to sign the tender:
 Full name (in BLOCK letters): _____

Signature: _____
 Date: _____

ROADS AND TRANSPORT DEPARTMENT
IRPTN DIVISION



INTERGRATED RAPID PUBLIC TRANSPORT NETWORK (IRPTN)

SUB-CONTRACTING PROCEDURES

TABLE OF CONTENTS

- 1. DEFINITIONS AND INTERPRETATIONS**
- 2. DEVELOPMENT PLANNING PHASE**
 - 2.1. Identification of Works Opportunities (IWO)
 - 2.2. IWO on Design Stage:
 - 2.3. IWO on Construction Stage:
- 3. TENDER PROCESS PHASE**
 - 3.1. Tender process for BEs
 - 3.2. Tender invitation
 - 3.3. Compilation and issue of tender documents
 - 3.4. Facilitation of a Site Briefing Session
 - 3.5. Pre-Tender Assistance to the BEs
 - 3.6. Adjudication
 - 3.7. Award of Tender
 - 3.8. Sub-Contract Agreement
- 4. CONSTRUCTION PHASE**
 - 4.1. Programming and monitoring
 - 4.2. Attendance on subcontractors
- 5. POTENTIAL BE WORK PACKAGES**
 - 5.1. Identified Packages

1. DEFINITIONS AND INTERPRETATIONS

For the purposes of this section of the Project Specification, the definitions given in the General Conditions of Contract for Construction Works 2015, the Standard Specifications and the Project Specifications, together with the following definitions shall apply:

- (a) **"Project Manager"** this refer to the consultant that has been appointed by the City of Tshwane to manage the planning, design and construction of the BRT Infrastructure.
- (b) **"Main Contract"** Any contract for the execution of civil engineering or building or similar construction works, in which the liabilities and responsibilities of the two parties thereto are assigned essentially in a manner which is consistent with that set out in the General Conditions of Contract for Construction Works 2010.
- (c) **"Project Management Team (PMT)"** A team that is set up after award of the contract, consisting of the Contractor, the Engineer, a delegated person from the Employer and member of the Project Management consultant. The function of the PMT will be to consult regarding the management of the subcontracts involving BEs. The PMT will also evaluate the Contractor's performance regarding the goals set for BE involvement. The Employer's Project Manager and or the Project Management Consultant will to decide of which party is to chair and lead the team. Minutes of these meetings will be taken by the Engineer.
- (d) **"BE Construction Manager"**: Person provided by Contractor to guide, assist and mentor all eligible potential BEs tendering and awarded a contract as BE Subcontractors as per section 4.4 of this Specification Document.
- (e) **"Black Enterprise (BE)"**: A 'Black Enterprise' (BE) is defined as a company or economic activity that is at least 50.1% owned by black people and where there is substantial management control by black people. Ownership refers to economic interest, whilst management refers to the membership of any board or similar governing body of the enterprise. **Such company need to be registered with the CIDB – Level 1 to 4.**
- (f) **"(Black People (BP))"**: 'Black people' (BP) are defined as Africans, Coloureds and Indians who hold South African Citizenship through their birth-right.
- (g) **Subcontractor**: A contractor who contracts with the Main Contractor to provide works as part of the total services required by the Employer for that Contract.
- (h) **Selected subcontractor**: A contractor who is included on the employer's data base of contractors from which the main contractor shall source subcontractors. The term selected subcontractor and BE shall be the same person/contractor.
- (i) **BE Package**: Specified work package identified for execution by BE's. The identifiers are Employer, Main Contractor and Management Team.
- (j) **Joint Venture**: An association of firms, companies or businesses for which purpose they combine their expertise, efforts, skills and knowledge to execute the Contract.
- (k) **Local community**: The local community for the purposes of the Tshwane Rapid Transit project will be considered areas considered to be historically disadvantaged area, provided that for the line, including subservient and supportive services, in:

- The north and west of the Rainbow Junction Area, including the last mentioned, will be the City of Tshwane Northern Region;
- The east of Hatfield, will be the City of Tshwane Eastern Region; and
- All other portion of the line will include the whole of the City of Tshwane area.

2. DEVELOPMENT PLANNING PHASE

The development planning is a preparatory phase which concentrates on establishment of the Identification of Sustainable Works Opportunities.

2.1. Identification of Works Opportunities (IWO)

The process of identification of works opportunities process will be carried out in a number of stages on the Project, at design, tender and construction stage.

2.2. IWO on Design Stage:

The design team led by the Engineer will identify sustainable works opportunities to be performed by BEs. This process will be guided by the Employer's developmental objectives. A **Value Engineering Session** will be held and bill of quantities to test the maximum beneficiation and meeting of the client objective.

2.3. IWO on Construction Stage:

During the construction stage, the Contractor or Employer through relevant structures (PMT or Project Review Meeting) may identify additional work to be performed by BEs. This additional work will also follow the specification in terms of scheduling and procuring BEs for such work.

The Contractor will note that all work measured in the Bills of Quantities is the Contractor's sole responsibility. This also applies where BEs have been identified for a particular portion of works in its entirety.

The BEs will be responsible for procuring all required materials, labour, equipment and any other incidentals to undertake the works subcontracted to them unless otherwise specified by Employer before tender or approved by the Project Management Team during construction. The Contractor will supervise and manage the BE work at all times to ensure compliance with the specifications and drawings. (To be included in contract information)

3. TENDER PROCESS PHASE

According to the agreed BE Works Packages Schedule, the Contractor will start with procurement of BEs to partake in the tendering or quotation process. At least 30% of the tender value shall be subcontracted to BE subcontractors. Of this 30%, 30% shall be local sub-contractors.

Within three working days, the Project Manager will forward the list of selected subcontractors and other subcontractors together with any other relevant information such as; the contact person, contact numbers, and CIDB grades. Any problems encountered during invitation should be reported back to Project Manager or the PMT meeting before the Site Inspection Meeting (sometimes referred to as the Mandatory meeting).

3.1. Tender process for BEs

The following process will be enforced unless agreed otherwise with Project Management Team.

3.2. Tender invitation

A minimum of 3 (three) shall be invited to tender for each subcontract to be performed by BEs.

3.3. Compilation and issue of tender documents

The Contractor shall compile the tender documents in such a manner that it will facilitate the achievement of all objectives and principles pertaining to procurement and development of BEs as stated in or as may reasonably be inferred from the conditions of this contract.

All tender documentation shall be reviewed, approved by the Engineer and issued by the Contractor.

The Sub-Contract Agreement in accordance with the SAFCEC will be compiled by the Main Contractor with the assistance of the Engineer. The Main Contractor shall be responsible for the compilation of each subcontract agreement and ensuring that the terms and conditions are consistent with all requirements as specified in or reasonably to be inferred from the provisions of this Contract. All costs associated with the tender process including the conclusion of the agreement are for the Contractor's account.

In addition to the provisions of clause 6 of the General Conditions of Contract for Construction Works 2015, the final terms and conditions of each subcontract agreement shall be subject to the approval of the Employer, which approval shall be obtained by the Contractor prior to entering into the subcontract agreement.

The Contractor may not enter into any subcontract agreement that contains terms more onerous or disproportionate to the risks inherent in the main contract for either the BE or the Contractor. The Contractor is required to use a standard form of subcontract and follow recommended which will be placed on SAFCEC sub-contract agreement with any necessary amendments.

3.4. Facilitation of a Site Briefing Session

The Contractor shall facilitate a Site Briefing Session for the invited BEs. The Main Contractor will also make sure that all relevant parties (PMT) are present and given an opportunity to present specific aspects of the requirements pertaining to their tender sections.

3.5. Pre-Tender Assistance to the BEs

At the briefing session, the Main Contractor assisted by the Project Manager and Engineer shall be responsible for ensuring that prospective BE Tenderers fully comprehend the:

- implications of the liabilities and responsibilities inherent in the particular basic level of subcontract applicable;
- scope and extent of the portion of the works included in the subcontract;
- the requirements for quality control of works
- the requirements for occupational health and safety
- proper procedures for the submission of the tenders;
- procedures and basis on which tenders will be adjudicated and the subcontracts awarded.

All the above should happen on the tender briefing session.

3.6. Adjudication

(a) The Contractor shall receive all tenders at a location identified by him. All sealed tender submissions will be placed in a proper tender box provided by the Contractor for this purpose. A submission register will be maintained by the Contractor for all tenders received.

(b) All tenders received shall be evaluated by the Contractor for final approval. The draft tender evaluation report shall be distributed to the PMT members 5 working days prior to the PMT meeting for comments and perusal in order to finalize the evaluation before the meeting. The format of the tender evaluation report must be agreed upon at the first PMT meeting.

The evaluation of the Occupational Health and Safety plans will be done by the Contractor SHE Officer.

(c) The PMT shall have the right to interview any tenderer for the purpose of:

- clarifying any aspect of the tender;
- querying abnormally high or low rates and prices, and

- clarifying rates and prices which are not in balance with other tendered rates and prices.
- (d) The Contractor shall provide all reasonable opportunity to such tenderers who have been interviewed, to correct obvious and blatant errors, provided always that this can be achieved without altering the total tendered sum.

3.7. Award of Tender

The Contractor shall explain his evaluation process to the Project Management Team for endorsement. All enquiries about the process thereafter will be referred to the Employer. The successful Contractor will award the work to the successful BE Tenderer where after a subcontract agreement will be signed between the Contractor and the successful BE Tenderer.

3.8. Sub-Contract Agreement

In accordance with the provisions of Clause 4 of the General Conditions of Contract for Construction Works 2015 and subject always to the further provisions of this specification, the terms and conditions of each subcontract agreement shall be as mutually agreed in writing between the Contractor and the BE. Each subcontract agreement, which is entered into by the Contractor in accordance with the requirements of this specification, shall contain terms and conditions, which assign the responsibilities and liabilities of the two parties to the subcontract.

The terms and conditions of the subcontract agreement shall specifically ensure that the provisions of this contract pertaining to:

- (a) the allowable sources from which workers may be drawn in terms of the contract;
- (b) the terms and conditions relating to the recruitment, employment and remuneration of workers engaged on the contract works; and
- (c) any training to be provided to the temporary workforce;
- (d) Occupational health and safety.
- (e) Use of labour-intensive methods

shall apply as is in respect of all workers engaged and employed by any BE.

4. CONSTRUCTION PHASE

4.1. Programming and monitoring

- The Contractor shall be required to provide as part of his initial programme (Clause 5.6 of GCC 2015) and updated as necessary in accordance thereof the following:
 - Clear indication in the programme the timing and duration of each BE subcontractor.
 - Projected cash flow aligned to the programme for BE subcontractors.
- Only work certified by the Engineer as having been completed by the BE subcontractor shall be eligible for inclusion in meeting the 25% value of the Works.
- The Contractor will be required to provide proof of payments to BE subcontractor's on a monthly basis as part of the payment certificate. Proof shall as a minimum consist of a signed copy of the subcontractor's invoice to the Contractor for inclusion in the interim payment certificates and the subcontractor's interim payment certificate summary page in a format to be approved by the Engineer.
- The Employer reserves the right to request documentary proof of such payments and shall entitle the Employer to terminate the Contract if the payments have not been made in accordance with certified interim payment certificates.
- The Contractor shall be required to ensure that payment to BE subcontractors shall not deviate by more than 20% of the programmed value in any interim monthly payment certificate. Failure by the Contractor to achieve this shall require substantiation and if necessary adjustment of the programme to indicate how compliance will be achieved.
- Failure to meet the Target Value at the Practical Completion date shall entitle the Employer to sanction as specified in C3.3.2.5.

4.2. Attendance on subcontractors

The Contractor shall in terms of the Clause 4.4.3 of the General Conditions of Contract for Construction Works (third edition 2015) be responsible for the subcontractors' acts, faults and defects as if they were his own.

5. POTENTIAL BE WORK PACKAGES

The operations likely to be carried by BE-Subcontractors will be as below, but not limited to.

5.1. Identified Packages

Examples of sections of the Bill of Quantities where-in tasks for BE Subcontracting may be identified.

Note: This list is not necessarily complete in order for the Contractor to comply with the BE requirements

GENERAL

General Requirements and Charges

ANCILLARY WORK

Site Clearing and Grubbing Accommodation of Traffic Service Ducts

EARTHWORKS

Trenching

SEWERS

Construction Testing

WATER

Construction Testing

DRAINAGE AND EROSION PROTECTION

Subsurface Drains and Drainage Blankets Prefabricated Culverts and Stormwater Sewers Kerbing and Channelling

Open Drains

ROADS AND PARKING AREAS

Segmented Paving Traffic Markings

ROAD SIGNS

Construction

PART C1: AGREEMENTS AND CONTRACT DATA

TABLE OF CONTENTS

C1.1	FORM OF AGREEMENT
	ACCEPTANCE
	SCHEDULE OF DEVIATIONS
C1.2	CONTRACT DATA
C1.3	FORM OF GUARANTEE
C1.4	GUARANTEE (CASH DEPOSIT)
C1.5	HEALTH AND SAFETY AGREEMENT
C1.6	AD-HOC ADJUDICATOR'S AGREEMENT

C1.1 FORM OF AGREEMENT

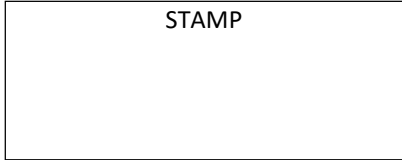

The employer, identified in the acceptance signature block, has solicited offers to enter into a contract in respect of the following works:

Contract: RTD004 2023/24: INTEGRATED RAPID PUBLIC TRANSPORT NETWORK (IRPTN) PROJECT: UPGRADING OF IRPTN LINE 3 INTERIM OPERATIONS: PRINCE'S PARK AND BUS STOPS/BAYS ALONG WF NKOMO STREET

The tenderer, identified in the offer signature block below, has examined the documents listed in the tender data and addenda thereto as listed in the returnable schedules, and by submitting this offer has accepted the conditions of tender.

By the representative of the tenderer, deemed to be duly authorised, signing this part of this form of offer and acceptance, the tenderer offers to perform all of the obligations and liabilities of the contractor under the contract including compliance with all its terms and conditions according to their true intent and meaning for an amount to be determined in accordance with the conditions of contract identified in the contract data.

THE OFFERED TOTAL OF PRICES INCLUSIVE OF VALUE ADDED TAX IS

R _____ *(in figures)*
_____ *(in words)*

This offer may be accepted by the employer by signing the acceptance part of this form of offer and acceptance and returning one copy of this document to the tenderer before the end of the period of validity stated in the tender data, whereupon the tenderer becomes the party named as the contractor in the conditions of contract identified in the contract data.

FOR AND ON BEHALF OF THE TENDERER:

NAME: _____
(in BLOCK letters)

CAPACITY: _____
(of authorized agent)

SIGNATURE: _____

SIGNED AT _____ on this _____ day of _____

WITNESSES:
(in BLOCK letters)
1. _____
2. _____

ACCEPTANCE

By signing this part of this Form of Offer and Acceptance, the Employer identified below accepts the Tenderer's Offer. In consideration thereof, the Employer shall pay the Contractor the amount due in accordance with the Conditions of Contract identified in the Contract Data. Acceptance of the Tenderer's Offer shall form an agreement between the Employer and the Tenderer upon the terms and conditions contained in this Agreement and in the Contract that is the subject of this Agreement.

The terms of the contract are contained in

- Part C1 Agreements and Contract Data, (which includes this Agreement)
- Part C2 Pricing Data
- Part C3 Scope of Work
- Part C4 Site Information

and drawings and documents or parts thereof, which may be incorporated by reference into Parts C1 to C4 above.

Deviations from and amendments to the documents listed in the Tender Data and any addenda thereto listed in the Tender Schedules as well as any changes to the terms of the Offer agreed by the Tenderer and the Employer during this process of offer and acceptance, are contained in the Schedule of Deviations attached to and forming part of this Agreement. No amendments to or deviations from said documents are valid unless contained in this Schedule, which must be duly signed by the authorised representative(s) of both parties.

The Tenderer shall within two weeks after receiving a completed copy of this Agreement, including the Schedule of Deviations (if any), contact the Employer's agent (whose details are given in the Contract Data) to arrange the delivery of any bonds, guarantees, proof of insurance and any other documentation to be provided in terms of the Conditions of Contract identified in the Contract Data at, or just after, the date this Agreement comes into effect. Failure to fulfil any of these obligations in accordance with those terms shall constitute a repudiation of this Agreement.

Notwithstanding anything contained herein, this Agreement comes into effect on the date when the Tenderer receives one fully completed original copy of this document, including the Schedule of Deviations (if any). Unless the Tenderer (now Contractor) within five days of the date of such receipt notifies the Employer in writing of any reason why he cannot accept the contents of this Agreement, this Agreement shall constitute a binding contract between the parties,

FOR AND ON BEHALF OF THE EMPLOYER:

NAME: _____
(in BLOCK letters)

CAPACITY: _____
(of authorized agent)

SIGNATURE: _____

SIGNED AT _____ on this _____ day of _____

WITNESSES:
(in BLOCK letters)

1. _____
2. _____

SCHEDULE OF DEVIATIONS

Notes:

- 1. The extent of deviations from the tender documents issued by the employer prior to the tender closing date is limited to those permitted in terms of the conditions of tender;
- 2. A tenderer's covering letter shall not be included in the final contract document. Should any matter in such, letter, which constitutes a deviation as aforesaid become the subject of agreements reached during the process of, offer and acceptance, the outcome of such agreement shall be recorded here;
- 3. Any other matter arising from the process of offer and acceptance either as a confirmation, clarification or change to the tender documents and which it is agreed by the parties becomes an obligation of the contract shall also be recorded here;
- 4. Any change or addition to the tender documents arising from the above agreements and recorded here shall also be incorporated into the final draft of the contract.

4.1 Subject: Details: _____

4.2 Subject: Details: _____

4.3 Subject: Details: _____

4.4 Subject: Details: _____

4.5 Subject: Details: _____

By the duly authorised representatives signing this agreement, the Employer and the Tenderer agree to and accept the foregoing Schedule of Deviations as the only deviations from the amendments to the documents listed in the Tender Data and addenda thereto as listed in the Tender Schedules, as well as any confirmation, clarification or change to the terms of the offer agreed by the Tenderer and the Employer during this process of offer and acceptance.

It is expressly agreed that no other matter whether, oral communication or implied during the period between the issue of the tender documents and the receipt by the Tenderer of a completed signed copy of this Agreement shall have any meaning or effect in the contract between the parties arising from this Agreement.

FOR AND ON BEHALF OF THE TENDERER:

NAME: _____
(in BLOCK letters)

CAPACITY: _____
(of authorized agent)

SIGNATURE: _____

SIGNED AT _____ on this _____ day of _____

WITNESSES:
(in BLOCK letters)

1. _____
2. _____

FOR AND ON BEHALF OF THE EMPLOYER:

NAME: _____
(in BLOCK letters)

CAPACITY: _____
(of authorized agent)

SIGNATURE: _____

SIGNED AT _____ on this _____ day of _____

WITNESSES:
(in BLOCK letters)

1. _____
2. _____

C1.2 CONTRACT DATA

TABLE OF CONTENTS

- C.1.2.1 CONDITIONS OF CONTRACT
- C.1.2.2 VARIATIONS AND ADDITIONS TO THE CONDITIONS OF CONTRACT
- C.1.2.3 DATA PROVIDED BY THE EMPLOYER
- C.1.2.4 DATA PROVIDED BY THE CONTRACTOR

C.1.2.1 CONDITIONS OF CONTRACT

The conditions of contract applicable to this contract shall be the General Conditions of Contract for Construction Works, Third Edition (2015) of the South African Institution of Civil Engineering (SAICE), read together with the Variations and Additions to the Conditions of Contract as well as the Data provided by Employer.

Should there be any contradicting conditions/statements between these Conditions of Contract and any other part of the tender documents/specifications, the Employer's Agent will give clarity on which version applies to this contract. For pricing purposes, the Contractor must take the least favourable meaning into consideration when tendering, no claims will be considered attributable to the contradicting conditions/statements.

Tenderers, contractors and subcontractors shall obtain their own copies of the document General Conditions of Contract for Construction Works, Third Edition (2015) for tendering purposes and for use for the duration of the contract from the Secretary of the South African Institution of Civil Engineering, Private Bag X200, Halfway House, Midrand, 1685 and shall bear all expenses in this regard.

C1.2.2 VARIATIONS AND ADDITIONS TO THE CONDITIONS OF CONTRACT

The following variations and additions to the General Conditions of Contract for Construction Works, Third Edition (2015), shall apply to this contract:

CLAUSE / SUB-CLAUSE	VARIATION / ADDITION
1.1.1.5	"Commencement Date" means the date 7 calendar days after the receipt by the Employer a permit to do construction work in terms of Regulations 3(1) and (2) of the Construction Regulations 2014"
1.1.1.13	The Defects Liability Period is twelve (12) calendar months from the date of the Certificate of Completion for a Work Order.
1.1.1.14	The time for achieving Practical Completion is 18 Months
1.1.1.15	The name of the Employer is the City of Tshwane.
1.1.1.16	The Employer's Agent is Imbawula Civil Projects (Pty) Ltd
1.1.1.16	Add the following to this clause: Any reference to "The Engineer" in the tender documents, including the technical specifications, shall have the same meaning as the "Employer's Agent".
1.1.1.28	Replace with: The Scope of Works as described in the bid document is indicative of the nature and extent of the work which the Employer intends to have executed in terms of this Contract, and accordingly is not an undertaking that Works Orders will be issued to the Contractor in respect of all or any of the work described therein. Furthermore, the Employer shall not be limited by the Scope of Work as described in the contract data.
	New definitions:
1.1.1.35	Specialist Subcontractor: A subcontractor who is a specialist in his field and is appointed specifically to carry out a specialist task. The specialist subcontractor is appointed by and paid directly by the employer but will have, by prior arrangement with the main contractor, access to the site in order to carry out his specialist works. The main contractor will not be responsible or liable for any actions or works carried out by the specialist contractor.
1.1.1.36	Selected Subcontractor: A selected subcontractor is a contractor who has tendered for a portion of the works and/or who has been appointed by a third party to carry out certain works under this contract. The selected subcontractor will be required to submit a monthly certificate to the main contractor who will pay him within seven (7) days of being paid by the employer. The contents of clause 4.4.3 will not apply to the selected subcontractor and he is wholly liable for his own acts, defaults and negligence.
1.1.1.37	BE Subcontractor: A BE Subcontractor is a contractor who has been appointed by the Main Contractor who complies to the conditions set in Part T3. He shall be subjected to the same conditions normally applying to subcontractors on any civil engineering contract, as per GCC 2015 and will be paid by the Main Contractor.

CLAUSE / SUB-CLAUSE	VARIATION / ADDITION
4.3	<p>Add the following the new sub-clause:</p> <p>4.3.3 <i>Wages and conditions of work:</i></p> <p>i. <i>For conventional construction works the Basic Conditions of Employment Act of 1997 (Act No 75 of 1997) shall apply and the minimum employment conditions which will apply shall be guided by the latest Sectorial Determination: Civil Engineering Sector published from time to time.</i></p> <p>ii. <i>Basic Conditions of Employment Act of 1997 (Act No 75 of 1997) as per Government Notice R63 of 25 January 2002, shall apply to works described in the Scope of Work as being labour intensive and which are undertaken by unskilled or semi-skilled workers.</i></p>
4.3	<p>Add the following new sub-clause:</p> <p>4.3.4 <i>Notwithstanding any actions which the Employer may take, the Contractor accepts sole liability for due compliance with the relevant duties, obligations, prohibitions, arrangements and procedures imposed by the Occupational Health and Safety Act, 1993 (Act 85 of 1993), and all its regulations, including the Construction Regulations, 2014, for which he is liable as mandatory. By entering into this Contract, it shall be deemed that the parties have agreed in writing to the above provisions in terms of Section 37(2) of the Act. The Contractor shall sign the Occupational Health and Safety Agreement for Contract Work in the City of Tshwane Metropolitan Municipality included in section C1.5.</i></p>
4.3	<p>Add the following new sub-clause:</p> <p>4.3.5 <i>The Employer retains an interest in all inquiries conducted under this Contract in terms of Section 31 and/or 32 of the Occupational Health and Safety Act, 1993 (Act 85 of 1993) and its Regulations following any incident involving the Contractor and/or Subcontractor and/or their employees. The Contractor shall notify the Employer in writing of all investigations, complaints or criminal charges which may arise pursuant to work performed under this Contract in terms of the Occupational Health and Safety Act, 1993 (Act 85 of 1993) and Regulations.</i></p>
4.3	<p>Add the following new sub-clause:</p> <p>4.3.6 <i>Contractor's Designer</i></p> <p><i>The Contractor and his designer shall accept full responsibility and liability to comply with the Occupational Health and Safety Act, 1993 (Act 85 of 1993) and the Construction Regulations, 2014 for the design of the Temporary Works and those part of the Permanent Works which the Contractor is responsible to design in terms of the Contract.</i></p>
4.4	<p>Add the following to clause 4.4.2 after the last sentence:</p> <p>4.4.2 <i>Liability for subcontractors:</i></p> <p><i>The Contractor shall not subcontract any part of the Contract without the prior written consent of the Employer's Agent and the Client, which consent shall not be unreasonably withheld.</i></p> <p><i>This clause 4.4.2 does not apply to a selected subcontractor.</i></p>
5.12.2.2	<p>Add the following to this sub-clause:</p>

CLAUSE / SUB-CLAUSE	VARIATION / ADDITION																								
	<p>No extension of time will be granted in respect of any delays attributed to normal climatic conditions. Normal climatic conditions shall be deemed to include normal rainfall and associated wet conditions and materials, strong winds and extremes of temperature. However, in the event that delays to critical activities exceed the number of working days listed below for each month, then abnormal climatic conditions shall be deemed to exist, and an extension of time may be claimed in accordance with the provisions of Clause 5.12.</p> <p>The number of days quoted below contains data which may assist the contractor in making allowances in the programme of work for delays due to rainfall (days on which 10mm of rain or more has been measured by the weather station at Pretoria University Proefplaas.)</p> <table border="1" data-bbox="344 640 616 1059"> <tr><td>January</td><td>6 days</td></tr> <tr><td>February</td><td>4 days</td></tr> <tr><td>March</td><td>5 days</td></tr> <tr><td>April</td><td>5 days</td></tr> <tr><td>May</td><td>2 days</td></tr> <tr><td>June</td><td>2 days</td></tr> <tr><td>July</td><td>0 days</td></tr> <tr><td>August</td><td>0 days</td></tr> <tr><td>September</td><td>2 days</td></tr> <tr><td>October</td><td>4 days</td></tr> <tr><td>November</td><td>10 days</td></tr> <tr><td>December</td><td>5 days</td></tr> </table> <p>Claims for delays for abnormal climatic conditions shall be submitted timeously and shall be accompanied by substantiating facts and evidence including photos of the rain gauge that shows the amount of rainfall for each day or half-day delay is experienced.</p> <p>It shall be further noted that where the critical path is not affected, no extension of time for abnormal climatic conditions or for any other reason will be entertained.</p>	January	6 days	February	4 days	March	5 days	April	5 days	May	2 days	June	2 days	July	0 days	August	0 days	September	2 days	October	4 days	November	10 days	December	5 days
January	6 days																								
February	4 days																								
March	5 days																								
April	5 days																								
May	2 days																								
June	2 days																								
July	0 days																								
August	0 days																								
September	2 days																								
October	4 days																								
November	10 days																								
December	5 days																								
5.12	<p>Add the following new sub-clause</p> <p><i>5.12.5 Critical path provision</i></p> <p><i>A delay in so far as extension of time is concerned, will be regarded as a delay only if, on a claim by the Contractor in accordance with the General Conditions of Contract, the Employer's Agent rules that all progress on an item or items of work on the critical path of the approved base programme or programme accepted from time to time for the execution of the Works by the Contractor, has been brought delayed.</i></p>																								
6.1	<p>Add the following new sub-clause:</p> <p><i>6.1.2 Payment for works identified in the Scope of Work as being labour-intensive shall only be made in accordance with the provisions of the Contract if the works are constructed strictly in accordance with the provisions of the Scope of Work. Any non-payment for such works shall not relieve the Contractor in any way of his obligations either in contract or in delict.</i></p>																								

CLAUSE / SUB-CLAUSE	VARIATION / ADDITION
6.1	<p>Add the following new sub-clause:</p> <p>6.1.3 <i>The Contractor shall be paid at Pretoria in the currency of the Republic of South Africa only at the Office of the Chief Financial Officer of the CITY OF TSHWANE, unless otherwise stated in the Data provided by Employer.</i></p>
6.2	<p>Add the following new sub-clause:</p> <p>6.2.4 <i>As an alternative to a performance guarantee, the Contractor may deposit with the Employer a cash amount in a sum equal to the amount stated in the Data provided by Employer. All the provisions in respect of the performance guarantee apply mutatis mutandis to the cash deposit except that the amount deposited will be repaid to the Contractor within 30 (thirty) days after the issue of the Certificate or Certificates of Completion in respect of the whole of the permanent works.</i></p>
6.6	PC Sum and Prov Sums to be handled as variation orders.
6.11	Variation exceeding 15 per cent. Remove this clause.
6.12	<p>Add the following new sub-clause:</p> <p>6.12 Evidence of Payments</p> <p>Before issuing a Payment Certificate which includes an amount payable to a BE Subcontractor, the Engineer may request the Contractor to supply reasonable evidence that the BE Subcontractor has received all amounts due in accordance with the previous Payment Certificates, less applicable deductions for retention or otherwise. Unless the Contractor:</p> <p>(a) submits this reasonable evidence to the Engineer, or</p> <p>(b) (i). satisfies the Engineer in writing that the Contractor is reasonably entitled to withhold or refuse to pay these amounts, and (ii). submits to the Engineer reasonable evidence that the BE Subcontractor has been notified of the Contractor's entitlement,</p> <p>then the Employer may (at the Employer's sole discretion) pay, directly to the BE Subcontractor, part or all of such amounts previously certified (less applicable deductions) as are due to the BE Subcontractor and for which the Contractor has failed to submit the evidence described in sub-paragraphs (a) or (b) above.</p> <p>Thereafter, the Engineer shall give a Notice to the Contractor stating the amount paid directly to the BE Subcontractor by the Employer and, in the next IPC after this Notice, shall include this amount as a deduction.</p>
8.3	<p>Add new sub-clause 8.3.1.14</p> <p>The effects of COVID-19 are more onerous than was apparent at the Base Date.</p>

C1.2.3 DATA PROVIDED BY THE EMPLOYER

DATA			
1.1.1.13	The Defects Liability Period from the date of the Certificate of Completion is:	12 calendar months	
1.1.1.14	The time for achieving Practical Completion from the Commencement Date is:	18 calendar months	
1.1.1.15	The legal name of the Employer is:	City of Tshwane	
1.1.1.16	The name of the Engineer is:	Mr. Tamsanqa Tom	
1.1.1.26	The Pricing Strategy is:	Re-measurement Contract	
1.2.1.2	The address of the Employer is:	Physical Address:	2 nd Floor (Info Tech Building) Arcadia Street Hatfield 1090
		Postal Address:	P.O. Box 1409 PRETORIA 0001
		Facsimile:	012 358 4923
		E-Mail Address:	
1.2.1.2	The address of the Employer's Agent is:	Physical Address:	Plot 70, 1463 Tienie Street Andeon A/H Pretoria west 0183
		Postal Address:	P.O Box 9784 Pretoria 0183
		Facsimile:	None
		E-Mail Address:	admin@imbawulacp.co.za

3.2.3	The Employer's Agent is required to obtain approval of the Employer:	
	<ul style="list-style-type: none"> • for expenditure on the Contract to exceed the Contract Sum; • prior to the execution of any of the following duties of functions: 	
	CLAUSE	DUTY/FUNCTION
	3.3.1	Nomination of person as Engineer's Representative
	3.3.4	Authorization to Engineer's Representative or any other person
	4.10.1	Approval to use the Site for any other purpose such as housing
	5.3.1	Delivery of the written notice to commence the execution of the works
	5.6.3	Approval of base programme of construction
	5.7.2	Permission to carry out work by day and by night
	5.8.1.1	Approval to work on special non-working days and between sunset and sunrise
	5.9.7	Approval of Contractor's designs
	5.11.2	Suspension of progress of the Works
	5.13.2	Reduction of penalty for delay
	5.14.2	The issue of a Certificate of Practical Completion
	5.14.4	The issue of a Certificate of Completion
	5.16.1	The issue of a Final Approval Certificate
	6.3.1	Variation Orders in respect of variations, Provisional Sums, PC Sums
	6.6	Instruction to expend on Provisional and Prime Cost Sums
	7.8.1	Order to execute work of repair, etc., during the Defects Liability Period
	7.8.2	Determination of details of repair work during defects liability period
8.2.2.2	Order to repair and make good damage arising from any excepted risk	

DATA		
5.3.1	The documentation required before commencement with Works execution are:	<ul style="list-style-type: none"> • Health and Safety Plan (Refer to Clause 4.3) • Initial programme (Refer to Clause 5.6) • Security (Refer to Clause 6.2) • Proof that all contributions required in terms of the provisions of the Workman's Compensation Act (Act no 30 of 1941) as amended in 1993, 2002 have been paid (Refer to Cause 4.3.2) • A certified copy of Unemployment Insurance Certificate, Act of 1996 (Refer to Clause 4.3.2) • Quality Plan • Contractor's Insurance (Refer: to clause 8.6 and Form RD.C.15)
5.3.2	The time to submit the documentation required from the Commencement Date is:	14 days calendar days
5.8.1	The non-working days are:	The following days unless approved by engineer: <ul style="list-style-type: none"> • All designated public holidays (including all foreseeable statutory declared election days) • Sundays
	Site work on Weekends	Site work can only be done upon approval from the engineer
	The special non-working days are:	The customary approximately 3-week long construction industry break during December and January of each year
5.8.1	Non-working Times	Unless approved by the engineer, no work will be permitted before 07:00 in the morning and after 17:00 in the afternoon
5.13.1	Penalty for failing to complete the Works is: Penalty accommodation of traffic Penalty environmental non-conformance	<ul style="list-style-type: none"> • R15 000.00 per calendar day or part thereof • Fixed per occurrence Series 0 Section 001 • Time-related (per hour) Series 0 Section 001 • Fixed per occurrence Series 1 Section 102 • Time-related (per hour) Series 1 Section 102
5.16.3	The latent defect period is:	10 Years
6.2.1	Type of security for due performance	Guarantee from approved financial institution or Cash deposit
	Liability of performance guarantee/cash deposit	10% of Contract Sum (Exclusive of contingencies and VAT) of the Contract Sum
6.2.2	Retention money guarantee	Not allowed

DATA																				
6.8.2	Adjustment in prices	<p>The value of the certificates issued shall be adjusted in accordance with the Contract Price Adjustment Schedule with the following values:</p> <table border="1" style="margin-left: auto; margin-right: auto;"> <thead> <tr> <th style="text-align: center;">Coefficient</th> <th style="text-align: center;">Description</th> <th style="text-align: center;">Value</th> </tr> </thead> <tbody> <tr> <td style="text-align: center;"><i>x</i></td> <td>Portion not subject to adjustment</td> <td style="text-align: center;">0,10</td> </tr> <tr> <td style="text-align: center;"><i>a</i></td> <td>Labour</td> <td style="text-align: center;">0,20</td> </tr> <tr> <td style="text-align: center;"><i>b</i></td> <td>Civil Engineering Plant</td> <td style="text-align: center;">0,35</td> </tr> <tr> <td style="text-align: center;"><i>c</i></td> <td>Civil Engineering Materials</td> <td style="text-align: center;">0,35</td> </tr> <tr> <td style="text-align: center;"><i>d</i></td> <td>Fuel</td> <td style="text-align: center;">0,10</td> </tr> </tbody> </table> <p>(The total of all Coefficients a, b, c and d must equal one)</p> <ul style="list-style-type: none"> • The urban area nearest the Site is Tshwane. • The base month is the month prior to the closing of the tender 	Coefficient	Description	Value	<i>x</i>	Portion not subject to adjustment	0,10	<i>a</i>	Labour	0,20	<i>b</i>	Civil Engineering Plant	0,35	<i>c</i>	Civil Engineering Materials	0,35	<i>d</i>	Fuel	0,10
Coefficient	Description	Value																		
<i>x</i>	Portion not subject to adjustment	0,10																		
<i>a</i>	Labour	0,20																		
<i>b</i>	Civil Engineering Plant	0,35																		
<i>c</i>	Civil Engineering Materials	0,35																		
<i>d</i>	Fuel	0,10																		
6.8.3	Price adjustments for variations in the cost of special materials	Only allowed for bitumen																		
6.10.2	The percentage advance on materials not yet built into the Permanent Works is:	80%																		
6.10.3	Percentage retention is:	10%																		
	The limit of retention money is:	5% of Contract Sum																		
10.5	Determination of disputes	Ad-hoc Adjudication Board																		
10.5.3	Number of Adjudication Board members to be appointed	Ad Hoc																		
10.6	Disagreement with Adjudication Board's decision, refer matters to:	Court proceedings																		

C1.2.4 DATA PROVIDED BY THE CONTRACTOR

CLAUSE	DATA			
1.1.1.9	The legal name of the Contractor is:			
1.2.1.2	The address of the Contractor is:	Physical Address:		
		Postal Address:		
		Facsimile:		
		E-Mail Address:		
6.2.1	The security to be provided by the Contractor shall be one of the following:	Type of security	Contractor's choice Indicate "Yes" or "No"	
		Performance guarantee (10 % of Contract Sum (Exclusive of contingencies and VAT))		
		Cash deposit (10 % of Contract Sum (Exclusive of contingencies and VAT))		
6.5.1.2.3	The percentage allowance to cover profits and overhead charges for dayworks is:	_____ (Max 15%)		
6.6.1.2.1	Commission on Provisional sums	_____ (Max 10%)		
6.8.2	Adjustment in prices (Contractor propose):	Coefficient	Description	Value
		<i>x</i>	Portion not subject to adjustment	0,10
		<i>a</i>	Labour	0.20
		<i>b</i>	Civil Engineering Plant	0.35
		<i>c</i>	Civil Engineering Materials	0.35
<i>d</i>	Fuel	0.10		

C1.3 FORM OF GUARANTEE

WHEREAS

The City of Tshwane
(hereinafter referred to as the "Council"),
enters into a Contract (No _____) with

_____ (hereinafter referred to as the "Contractor")

for _____

AND WHEREAS in terms of the General Conditions of the Contract the Contractor is required to furnish an acceptable independent guarantee for the due and proper fulfilment by him of all his duties and obligation in terms of the said contract.

NOW THEREFOR we the undersigned _____

_____ (full names of authorized agent(s))

and acting in my/ our capacity as _____

and _____

and as such duly authorized thereto, do hereby bind the said _____

(hereinafter referred to as the "Guarantor") as surety and co-principal Debtor *in solidum* for the sum of

R _____ (_____)

for the due and proper fulfilment by the Contractor of all or any of his duties and obligations in terms of the said Contract. The guarantee shall not be interpreted as accessory to the contract between Council and the Contractor.

The Guarantor further undertakes, in the event of the Contractor failing duly and properly to fulfil any of his duties and obligations in terms of the said Contract, or if the Contractor is placed under provisional liquidation or in the event of termination of the Contract by the Council in terms of the General Conditions of Contract, to pay to the Council the said sum of

R _____ (_____)

or such portion thereof as may be required by the Council, immediately upon receiving written demand from the Council which written demand shall be addressed to the Guarantor at (*domicilium* address)

non numerate pecuniae

Exception non causa debiti

Beneficium de duobus vel pluribus reis debendi

Beneficium ordinis de excussione

Beneficium divisionis

and all other defence which could be pleaded against the validity of this guarantee, with the meaning and effect of which it declares itself to be fully acquainted.

This undertaking shall remain in full force and effect up to and including the date of issue of the Certificate of Completion, as provided for in the General Conditions of Contract, unless the Guarantor is advised in writing by the Council of his intention to institute claims, and the particulars thereof, in which event this guarantee shall remain in full force and effect until all such claims have been paid or liquidated.

This document is not negotiable or transferable.

FOR AND ON BEHALF OF THE BANKER/ INSURER:

NAME: _____
(in BLOCK letters)

CAPACITY: _____
(of authorized agent)

SIGNATURE: _____

SIGNED AT _____ on this _____ day of _____

WITNESSES:
(in BLOCK letters)

1. _____

2. _____

Pro Forma

ANNEXURE

List of institutions from which contract /deposit guarantees can be accepted

1. ABSA Bank
2. Credit Agricole Indosuez (South Africa Branch)
3. Development Bank of South Africa
4. FirstRand Bank
5. ING Bank N.V. (South Africa Branch)
6. Investec Bank
7. Landbank
8. National Housing Finance Co.
9. Nedcor Bank
10. South African Reserve Bank
11. Standard Bank
12. AIG South Africa
13. Credit Guarantee Insurance Co
14. Emerald Insurance Company
15. Federated Employers Mutual Assurance Co
16. Global Insurance Company
17. Guardrisk Insurance Company
18. Hannover Re:
19. Home Loan Guarantee Company
20. Lion of Africa Insurance Company
21. Metropolitan Life
22. Metropolitan Odyssey Ltd
23. MUA Insurance
24. Mutual & Federal Insurance Company
25. Rand Mutual Assurance Company
26. Regent Insurance Company
27. SA Eagle Insurance Company
28. Lombard Insurance.

C1.4 GUARANTEE (CASH DEPOSIT)

Contract: **RTD04 2023/24– PRO-FORMA ONLY**
Description of Contract: **INTEGRATED RAPID PUBLIC TRANSPORT NETWORK (IRPTN) PROJECT:
UPGRADING OF IRPTN LINE 3 INTERIM OPERATIONS: PRINCE'S PARK AND BUS
STOPS/BAYS ALONG WF NKOMO STREET**

Employer: **CITY OF TSHWANE**

Contractor: _____

I/ We, the undersigned, deposit herewith ¹cash/ a bank certified cheque, in the amount of

as surety for the due performance of the Contract by the abovementioned Contractor, and for all losses, damages and expenses that may be suffered or incurred by the Employer as a result of non-performance of the Contract by the Contractor, renouncing all benefits from the legal exceptions *ordinis seu excussions et devisions* no value received and all other exceptions which might or could be pleaded against the surrender of this deposit.

This guarantee is independent and not accessory to any other obligation as reflected in the contract save that the cash amount shall, notwithstanding anything else contained herein, upon written request of the Employer be paid out to the Employer upon occurrence of any one or more of the following events:

- (a) the Contractor being placed under provisional liquidation or committing any one or more of the acts of insolvency as provided for in the Insolvency Act, 1936 (Act 24 of 1936);
- (b) failure to comply with the conditions of the contract by the contractor; or
- (c) if the contract is terminated.

A letter received from the Employer stating that any one or more of the aforementioned has occurred shall be sufficient notice to effect payment in terms of this guarantee.

The deposit shall, subject to the above, be returned to the Contractor on the issue of the Completion Certificate in terms of the Contract, unless the Contractor is advised in writing by the Employer before issue of the said Certificate of his intention to institute claims and the particulars thereof, in which event this deposit shall remain in force until all such claims are paid or settled.

¹ Delete which is not applicable

FOR AND ON BEHALF OF THE CONTRACTOR:

NAME: _____
(in BLOCK letters)

CAPACITY: _____
(of authorized agent)

SIGNATURE: _____

SIGNED AT _____ on this _____ day of _____

WITNESSES:
(in BLOCK letters)

1. _____

2. _____

Pro Forma

C1.5 HEALTH AND SAFETY AGREEMENT

Article of Agreement in terms of Section 37(2) of the Occupational Safety Act, 1993 between

CITY OF TSHWANE
(Hereinafter referred to as the "EMPLOYER")
AND

Herein represented by _____ in his/her capacity as _____ duly authorised by virtue of a resolution dated _____, attached hereto Annexure A, of the said _____ (herein after referred to as the "CONTRACTOR")

WHEREAS the CONTRACTOR is the mandatory of the EMPLOYER as contemplated in an agreement in respect of

**CONTRACT: RTD 04 2023/24 Integrated Rapid Public Transport Network (IRPTN) Project:
UPGRADING OF IRPTN LINE 3 INTERIM OPERATIONS: PRINCE'S PARK AND BUS STOPS/BAYS ALONG
WF NKOMO STREET**

AND WHEREAS section 37 of the Occupational Health and Safety act, 1993 (Act 85 of 1993, hereinafter referred to as the "ACT"), imposes certain powers and duties upon the EMPLOYER.

AND WHEREAS the parties have agreed to enter into an agreement in terms of section 37(2) of the ACT. NOW THEREFORE the parties agree as follows:

- (a) The CONTRACTOR undertakes to acquaint the appropriate officials and employees of the CONTRACTOR with all relevant provisions of the ACT and the regulations promulgated in terms thereof.
- (b) The CONTRACTOR undertakes that all relevant duties, obligations and prohibitions imposed in terms of the ACT and Regulations will be fully complied with. Provided that should the EMPLOYER prescribe certain arrangements and procedures, that same shall be observed and adhered to by the CONTRACTOR, his officials and employees. The CONTRACTOR shall bear the onus of acquainting himself/herself/itself with such arrangements and procedures.
- (c) The CONTRACTOR hereby accepts sole liability for such due compliance with the relevant duties, obligations, prohibitions, arrangements and procedure, if any, imposed by the ACT and Regulations and the EMPLOYER expressly absolves the EMPLOYER from itself being obliged to comply with any of the aforesaid duties, obligations, prohibitions, arrangements and procedure as the case may be.
- (d) The CONTRACTOR agrees that any duly authorised officials of the EMPLOYER shall be entitled, although not obliged, to take such steps as may be necessary to ensure that the CONTRACTOR has complied with the undertakings as more fully set out in paragraphs 1 and 2 above, which steps may include, but shall not be limited to, the right to inspect any appropriate site or premises occupied by the CONTRACTOR, or to inspect any appropriate records held by the CONTRACTOR or to take such steps it may deem necessary to remedy the default of the CONTRACTOR at the cost of the CONTRACTOR.
- (e) The CONTRACTOR shall be obliged to report forthwith to the EMPLOYER any investigations, complaint or criminal charge which may arise as a consequence of the provisions of the ACT and Regulations,

pursuant to work performed in terms of this agreement, and shall, on written demand, provide full details in writing of such an investigation, complaint or criminal charge as the case may be

FOR AND ON BEHALF OF THE CONTRACTOR:

NAME: _____
(in BLOCK letters)

CAPACITY: _____
(of authorized agent)

SIGNATURE: _____

SIGNED AT _____ on this _____ day of _____

WITNESSES:
(in BLOCK letters)

1. _____
2. _____

FOR AND ON BEHALF OF THE EMPLOYER:

NAME: _____
(in BLOCK letters)

CAPACITY: _____
(of authorized agent)

SIGNATURE: _____

SIGNED AT _____ on this _____ day of _____

WITNESSES:
(in BLOCK letters)

1. _____
2. _____

C1.6 AD-HOC ADJUDICATOR'S AGREEMENT

This agreement is made on the _____ day of _____ between:

_____ (name of company / organisation)

of _____

_____ (address)
and

_____ (name of company / organisation)

of _____

_____ (address) (the Parties)
and

_____ (name of Adjudicator)

of _____

_____ (address) (the Adjudicator).

Disputes or differences may arise/have arisen¹ between the Parties under a Contract dated _____ and known as _____

and these disputes or differences shall be/have been² referred to adjudication in accordance with the CIDB Adjudication Procedure, (hereinafter called "the Procedure") and the Adjudicator may be or has been requested to act.

IT IS NOW AGREED as follows:

- 1 The rights and obligations of the Adjudicator and the Parties shall be as set out in the Procedure.
- 2 The Adjudicator hereby accepts the appointment and agrees to conduct the adjudication in accordance with the Procedure.
- 3 The Parties bind themselves jointly and severally to pay the Adjudicator's fees and expenses in accordance with the Procedure as set out in the Contract Data.
- 4 The Parties and the Adjudicator shall at all times maintain the confidentiality of the adjudication and shall endeavour to ensure that anyone acting on their behalf or through them will do likewise, save with the consent of the other Parties which consent shall not be unreasonably refused.
- 5 The Adjudicator shall inform the Parties if he intends to destroy the documents which have been sent to him in relation to the adjudication and he shall retain documents for a further period at the request of either Party.

¹ Delete which is not applicable
SIGNED BY: _____ SIGNEDBY: _____ SIGNED BY: _____

Name: _____ Name: _____ Name: _____

who warrants that he / she is duly who warrants that he / she is duly the Adjudicator in the presence of

authorized to sign for and on behalf of the first Party in the presence of _____
 authorized to sign for and on behalf of the second Party in the presence of _____

Witness

Witness

Witness

Name: _____

Name: _____

Name: _____

Address: _____

Address: _____

Address: _____

Date: _____

Date: _____

Date: _____

Contract Data

1	The Adjudicator shall be paid at the hourly rate of R_____ in respect of all time spent upon, or in connection with, the adjudication including time spent travelling.
2	The Adjudicator shall be reimbursed in respect of all disbursements properly made including, but not restricted to: (a) Printing, reproduction and purchase of documents, drawings, maps, records and photographs. (b) Telegrams, telex, faxes, and telephone calls. (c) Postage and similar delivery charges. (d) Travelling, hotel expenses and other similar disbursements. (e) Room charges. (f) Charges for legal or technical advice obtained in accordance with the Procedure.
3	The Adjudicator shall be paid an appointment fee of R_____ This fee shall become payable in equal amounts by each Party within 14 days of the appointment of the Adjudicator, subject to an Invoice being provided. This fee will be deducted from the final statement of any sums which shall become payable under item 1 and/or item 2 of the Contract Data. If the final statement is less than the appointment fee the balance shall be refunded to the Parties.
4	The Adjudicator is/is not ¹ currently registered for VAT.
5	Where the Adjudicator is registered for VAT it shall be charged additionally in accordance with the rates current at the date of invoice.
6	All payments, other than the appointment fee (item 3) shall become due 7 days after receipt of invoice, thereafter interest shall be payable at 5% per annum above the Reserve Bank base rate for every day the amount remains outstanding.

¹ Delete which is not applicable

**ROADS AND TRANSPORT DEPARTMENT
IRPT SPECIALISED UNIT**



TENDER REFERENCE: RTD 04 2023/24

**INTEGRATED RAPID PUBLIC TRANSPORT NETWORK (IRPTN)
PROJECT:
UPGRADING OF IRPTN LINE 3 INTERIM OPERATIONS: PRINCE'S
PARK AND BUS STOPS/BAYS ALONG WF NKOMO STREET**

VOLUME 2 of 3

A Tender for Category 7CE or higher CIDB registered Contractors

ISSUED BY:	PREPARED BY:
The Group Head: Roads and Transport <u>IRPTN DIVISION</u> PO Box 1409 PRETORIA 0001 Tel: 012 358-1064	Imbawula Civil Projects (Pty) Ltd PLOT 70, 1463 TIENIE STREET ANDEON A/H PRETORIA WEST 0183 Tel: 012 372 3807

Registered Name of Tenderer:	
Trading Name of Tenderer:	
Registration No. of Entity:	
Contact Person:	CoT Vendor No:
Tel. No:	E-Mail Address:
Cell No:	Fax No:
CIDB CRS Number (s):	

VOLUME 1 OF 3

- PART T1** TENDERING PROCEDURES
- PART T2** RETURNABLE DOCUMENTS
- PART T3** SUBCONTRACTING PROCEDURES
- PART C1** AGREEMENTS AND CONTRACT DATA

VOLUME 2 OF 3

- PART C2** PRICING DATA

VOLUME 3 OF 3

- PART C3** SCOPE OF WORK
- PART C4** SITE INFORMATION
- PART C5** ANNEXURES

PART C2: PRICING DATA

PART C2: PRICING DATA

TABLE OF CONTENTS

C2.1	PRICING INSTRUCTIONS
C2.2	PRICING SCHEDULE
C2.3	SUMMARY OF SCHEDULES
C2.4	CALCULATION OF TENDER SUM

C2.1 PRICING INSTRUCTIONS

C2.1.1 Measurement and payment shall be in accordance with the relevant provisions of the GCC as amended in the Scope of Works.

C2.1.2 The units of measurement described in the Pricing Schedule are metric units. Abbreviations used in the Pricing Schedule are as follows:

%	=	percent
h	=	hour
ha	=	hectare
kg	=	kilogram
kl	=	kilolitre
km	=	kilometre
km-pass	=	kilometre-pass
kPa	=	kilopascal
kW	=	kilowatt
l	=	litre
m	=	metre
mm	=	Millimeter
m ²	=	square metre
m ² -pass	=	square metre-pass
m ³	=	cubic metre
m ³ -km	=	cubic metre-kilometre
MN	=	meganewton
MN.m	=	meganewton-metre
MPa	=	megapascal
No.	=	number
Prov sum	=	Provisional sum
PC Sum	=	Prime Cost sum
R/only	=	Rate only
sum	=	lump sum
t	=	ton (1000kg)
W/day	=	Work day

C2.1.3 For the purpose of the Pricing Schedule, the following words shall have the meanings assigned to them:

Unit:	The unit of measurement for each item of work as defined in the GCC as amended.
Quantity:	The number of units of work for each item.
Rate:	The payment per unit of work for which the Service Provider tenders to do the work.
Amount:	The product of the quantity and the rate tendered for an item.
Lump Sum:	An amount tendered for an item, the extent of which is described in the Pricing Schedule, the Scope of Work or elsewhere, but of which the quantity of work is not measured in units.
Prime cost:	Is a specific type of Provisional Sum where payment is made on the production of invoices showing the cost price of the implementation or installation of the service required. Services rendered in this manner carry a mark-up for which a rate is offered

at tender stage to cover all the tenderer's handling, supervision and liability costs and profit in providing the item or services.

Provisional Sum: Means a sum (if any) which is specified in the contract as a provisional sum, for the execution of any part of the works or the supply of plant, materials or services under sub-clause 13.5 (Provisional sums).

- C2.1.4 Unless otherwise stated, items are measured net in accordance with the drawings, and no allowance is made for waste.
- C2.1.5 It will be assumed that prices included in the bills of quantities are based on Acts, Ordinances, Regulations, By-laws, International Standards and National Standards that were published 28 days before the closing date for tenders. (Refer to www.stanza.org.za or www.iso.org for information standards)
- C2.1.6 The prices and rates in the Pricing Schedule are fully inclusive prices for the work described under the items. Such prices and rates cover all costs and expenses that may be required in and for the execution of the work described in accordance with the provisions of the Scope of Work, and shall cover the cost of all general risks, liabilities and obligations set forth or implied in the Contract Data, as well as overhead charges and profit. These prices will be used as a basis for assessment of payment for additional work that may have to be carried out.
- C2.1.7 Where the Scope of Work requires detailed drawings and designs or other information to be provided, all costs associated therewith are deemed to have been provided for and included in the unit rates and sum amount tendered such items.
- C2.1.8 An item against which no price is entered will be considered to be covered by the other prices or rates in the Pricing Schedule. A single lump sum will apply should a number of items be grouped together for pricing purposes.
- C2.1.9 The quantities set out in the Pricing Schedule are approximate and do not necessarily represent the actual amount of work to be done. The quantities of work accepted and certified for payment will be used for determining payments due and not the quantities given in the Pricing Schedule.
- C2.1.10 Reasonable compensation will be received where no pay item appears in the Pricing Schedule in respect of work required in terms of the Contract and which is not covered in any other pay item.
- C2.1.11 The short descriptions of the items of payment given in the Pricing Schedule are only for the purposes of identifying the items. More details regarding the extent of the work entailed under each item appear in the Scope of Work.
- C2.1.12 The item numbers appearing in the Pricing Schedule refer to the corresponding item numbers in the Part C3: SCOPE OF WORKS, SECTION B3: PARTICULAR SPECIFICATION
- C2.1.13 The pricing schedules are provided electronically on the Compact Disc. A printout of the entire completed pricing schedule must be signed and attached to the tender as well as an electronic copy of the priced pricing schedule. In the event of any discrepancy between the signed printed copy, and the electronically submitted copy, the tender rates in the signed copy will govern. The item numbers and description of the PDF document will govern.

C2.2 PRICING SCHEDULE

SCHEDULE A: ROADWORKS

SERIES 0 GENERAL

- SECTION 001 GENERAL REQUIREMENTS AND CHARGES
- SECTION 002 ENGINEER'S ACCOMMODATION

SERIES 1 ANCILLARY WORK

- SECTION 101 SITE CLEARING AND GRUBBING
- SECTION 102 ACCOMMODATION OF TRAFFIC
- SECTION 103 OVERHAUL
- SECTION 106 SERVICE DUCTS
- SECTION B107 DAYWORKS

SERIES 2 EARTHWORKS

- SECTION 201 GENERAL
- SECTION 202 TRENCHING
- SECTION 203 MASS EARTHWORKS

SERIES 5 DRAINAGE AND EROSION PROTECTION

- SECTION 502 PREFABRICATED CULVERTS AND STORMWATER SEWERS
- SECTION 503 KERBING AND CHANNELLING

SERIES 6 ROADS AND PARKING AREAS

- SECTION 601 GRAVEL PAVEMENT LAYERS
- SECTION 602 CRUSHED-STONE PAVEMENT LAYERS
- SECTION 604 STABILISATION
- SECTION 605 PRIME COAT
- SECTION 606 ASPHALT BASE AND SURFACING
- SECTION 609 SEGMENTED PAVING
- SECTION 612 TRAFFIC SIGNS
- SECTION 613 TRAFFIC MARKINGS

SERIES 9 QUALITY CONTROL

- SECTION 202 TESTING

SCHEDULE B: ELECTRICAL WORKS

- SECTION 1 PRELIMINARY AND GENERAL
- SECTION 2 RETICULATION SYSTEM
- SECTION 3 STREET LIGHTING INSTALLATION
- SECTION 4 TELE-MANAGEMENT SYSTEM
- SECTION 5 PROVISION FOR FUTURE FIBRE INSTALLATION
- SECTION 6 REFURBISHMENT OF EXISTING STREET LIGHTING INSTALLATION (WF NKOMO STREET)
- SECTION 7 PROVISIONAL AMOUNTS

SCHEDULE A: ROADWORKS**SECTION 001**

ITEM	DESCRIPTION	UNIT	QTY	RATE	AMOUNT R
Section 001	SERIES 0 : GENERAL GENERAL REQUIREMENTS AND CHARGES				
001.01	Preliminary and General Charges				
001.01.01	Fixed charges	L/ Sum	1		
001.01.02	Time-related charges	L/ Sum	1		
001.02	Locating existing services	L/ Sum	1		
001.03	Excavate by hand to expose existing services, and backfill	m ³	1750		
001.04	Compliance with the Occupational Health and Safety Act and applicable regulations				
001.04.01	Provision of a Health and Safety plan	L/Sum	1		
001.04.02	Provision of Health and Safety file	L/Sum	1		
001.04.04	Provision of a Safety Officer (full-time)	month	18		
001.04.05	Health and safety training	L/Sum	1		
B001.04.06	Provision of personal protective clothing and equipment	L/Sum	1		
001.04.07	Provision of safety fences, signs and barricades	L/Sum	1		
B001.04.08	Other obligations				
B001.04.08.01	(a) Environmental obligations	month	18		
	(b) Health and safety obligations	month	18		
TOTAL CARRIED FORWARD					

SCHEDULE A: ROADWORKS

SECTION 001

TOTAL BROUGHT FORWARD						
B001.05	Community Liaison Officer					
B001.05.01	Monthly Salary	PC Sum	1	R	300 900,60	R 300 900,60
B001.06	Penalties to be deducted					
B001.06.02	Penalties for Non-compliance to environmental issues					
	(a) Fixed penalty per occurrence	No	Rate Only	-R	5 000,00	
	(b) Time related penalty, for continual non-	Day	Rate Only	-R	1 000,00	
B001.06.04	The contractor's general obligations:					
	(a) Fixed penalty per occurrence	No	Rate Only	-R	5 000,00	
	(i) Minor	No	Rate Only	-R	50,00	
	(ii) Medium	No	Rate Only	-R	500,00	
	(iii) Severe	No	Rate Only	-R	5 000,00	
	(b) Time related penalty	h	Rate Only	-R	500,00	
B001.07	Selected sub-contractors for specialist activities					
B001.07.01	Relocation and protection of services except electrical services	PC Sum	1	R	2 000 000,00	R 2 000 000,00
B001.07.02	Contractor's profit and handling cost in respect of B001.06.01	%	2 000 000,00			
TOTAL CARRIED FORWARD						

SCHEDULE A: ROADWORKS

SECTION 001

TOTAL BROUGHT FORWARD					
B001.07.03	Landscaping	PC Sum	1	R 1 000 000,00	R 1 000 000,00
B001.07.04	Contractor's profit and handling cost in respect of B001.0.07	%	1 000 000,00		
B001.08	Traffic Control Signals				
	(a) Provision and Installation of new and/or upgrading and relocating of existing traffic control signals by the City of Tshwane	Prov.Sum	1	R 1 400 000,00	R 1 400 000,00
	(b) Contractor's handling costs, profit and all other charges in respect of subitem B001.10.7(a)	%	1 400 000,00		
TOTAL CARRIED FORWARD					

SCHEDULE A: ROADWORKS**SECTION 002**

ITEM	DESCRIPTION	UNIT	QTY	RATE	AMOUNT R
	SERIES 0 : GENERAL				
Section 002	ENGINEER'S ACCOMMODATION				
002.01	Services				
002.01.01	Services for offices and laboratories	PC Sum	1	R 70 000,00	R 70 000,00
002.02	Treatment and maintenance of areas surrounding offices and laboratories	L/Sum	1		
B002.03	Office and laboratory accommodation				
B002.03.01	Provision of Engineer's Facilities including; Office accommodation, ablutions, all fittings, furniture, stationary, equipment and car ports, as specified in project specification	PC Sum	1	R 540 000,00	R 540 000,00
B002.04	Provision of survey equipment and assistants	L/ Sum	1		
TOTAL CARRIED FORWARD TO SUMMARY					

SCHEDULE A: ROADWORKS**SECTION 101**

ITEM	DESCRIPTION	UNIT	QTY	RATE	AMOUNT R
	SERIES 1 : ANCILLARY WORKS				
Section 101	CLEARING AND GRUBBING				
101,01	Clearing and grubbing				
101.01.01	Areas	m ²	5 520		
101,02	Cutting and removing large trees with a girth-				
101.02.01	exceeding 1,0m and up to and including 2,0m	No	42		
101.02.02	exceeding 2,0m and up to and including 3,0m	No	9		
101.02.03	exceeding 3,0m and up to and including 4,0m	No	0		
101,03	Grubbing and the removal of the stumps and roots of large trees with a girth:				
101.03.01	exceeding 1m and up to and including 2m	No	42		
101.03.02	exceeding 2m and up to and including 3m	No	9		
101.03.03	exceeding 3m and up to and including 4m	No	0		
101,05	Removal and Disposal of specific elements to a municipal dumping site including dumping site fees and unlimited free haul distance				
101.05.01	Concrete Kerbing / Kerbing combination	m	1 210		
101.05.02	Concrete or Brick elements				
	(a) Concrete, reinforced	m ³	79		
	(b) Concrete, unreinforced and paving blocks	m ³	196		
	(c) Brickwork	m ³	42		
101.05.03	Asphalt surfacing irrespective of thickness	m ²	5 060		
TOTAL CARRIED TO SUMMARY					

SCHEDULE A: ROADWORKS**SECTION 102**

ITEM	DESCRIPTION	UNIT	QTY	RATE	AMOUNT R
102	ACCOMMODATION OF TRAFFIC				
B102.01	Accommodation of traffic and maintenance of bypasses				
	(a) Along main road	km	1		
	(b) Intersections - Signallised	No	3		
	(c) Intersections - non Signallised	No	1		
	(d) Pedestrian traffic	L/Sum	1		
102,08	Maintenance of surfacing and pavement layers of bitumen- surfaced bypasses and existing bitumen-surfaced roads used as bypasses	Prov Sum	1	R 100 000,00	R 100 000,00
102,14	Temporary traffic control facilities				
B102.14.01	Flagmen	L/ Sum	1		
102.14.03	Amber flicker lights	No	10		
102.14.04	Road signs, TR-series, 1200 mm in diameter	No	37		
B102.14.05	Road signs, TW-series, 1200 mm sides	No	15		
102.14.06	Road signs, TG-series	m ²	10		
102.14.07	Danger plates and delineators	No	336		
102.14.08	Moveable barricades (chevron and ROAD CLOSED types)	No	9		
TOTAL CARRIED FORWARD					

SCHEDULE A: ROADWORKS

SECTION 102

ITEM	DESCRIPTION	UNIT	QTY	RATE	AMOUNT R
BROUGHT FORWARD					
102.14.10	Plastic new jersey barrier	no	336		
102,15	Re-use or removal of traffic control facilities	L/Sum	1		
102.15.01	Amber flashing lights mounted on signs	No	2		
102.14.04	Road signs, TR-series, 1200 mm in diameter	No	6		
102.14.05	Road signs, TW-series, 1200 mm sides	No	4		
102.14.06	Road signs, TG-series	m ²	2		
102.15.04	Danger plates and delineators	No	36		
102.15.05	Plastic new jersey barrier	No	36		
B102.17	Barriers				
	(a) Concrete:				
	Supply to site, initial placement, dismantling and re-erecting rented barriers during the works and removal from site of rented barriers	m	20		
TOTAL CARRIED TO SUMMARY					

SCHEDULE A: ROADWORKS**SECTION 103**

ITEM	DESCRIPTION	UNIT	QTY	RATE	AMOUNT R
103 103,01	SERIES 1 : ANCILLARY WORKS OVERHAUL Overhaul on material hauled outside the defined free-haul boundaries Note: The haul distance shall be from the free-haul boundaries of the contract to the entrance gate of the municipal dumping site. The tenderer must allow for any possible additional haul distance inside the municipal dumping site.	m ³ -km	56 925		
TOTAL CARRIED TO SUMMARY					

SCHEDULE A: ROADWORKS**SECTION 106**

ITEM	DESCRIPTION	UNIT	QTY	RATE	AMOUNT R
	SERIES 1 : ANCILLARY WORKS				
106	SERVICE DUCTS				
106,01	Bedding and backfilling up to 300mm above pipes				
106.01.01	Using Selected excavated material	m ³	29		
106.01.04	Using crushed stone	m ³	10		
106.01.05	Using stabilized material	m ³	10		
106,03	Soilcrete	m ³	5		
106,04	Service duct pipes				
106.04.01	Ordinary pipes				
106.04.01.01	110mm dia uPVC	m	4 000		
106.04.01.02	160mm dia uPVC	m	400		
106,05	Duct Markers	No			
106,06	Extra over items 106.01 and 106.03 for using material obtained from sources provided by the contractor	m ³	5		
B106.07	Manholes:				
B106.07.01	Supply and installation of prefabricated fibre cement manhole (Basix type)	No	80		
B106.08	Testing of ducts Mendrill test	L/Sum	1		
TOTAL CARRIED TO SUMMARY					

SCHEDULE A: ROADWORKS**SECTION 003**

ITEM	DESCRIPTION	UNIT	QTY	RATE	AMOUNT R
Section B107	DAYWORKS				
B107.01	Labour during normal working hours				
B107.01.01	Unskilled labour	h	200		
B107.01.02	Semi-skilled labour	h	150		
B107.01.03	Skilled labour (Artisan)	h	100		
B107.01.04	Ganger	h	100		
B107.01.05	Foreman	h	100		
B107.02	Equipment				
B107.02.01	Tipper Trucks	h	100		
B107.02.05	Generator (15kVA)	h	100		
B107.02.06	Grader (Mass 16-20 ton)	h	100		
B107.02.09	Pneumatic Roller (14-21 ton)	h	100		
B107.02.10	Pedestrian Roller	h	100		
B107.02.13	Pumps	h	100		
B107.03	Transport of Construction Equipment				
B107.03.01	LDV	km	100		
B107.03.02	Lowbed	km	100		
TOTAL CARRIED FORWARD TO SUMMARY					

SCHEDULE A: ROADWORKS**SECTION 201**

ITEM	DESCRIPTION	UNIT	QTY	RATE	AMOUNT R
SERIES 2	GENERAL				
Section 201	General				
201.01	Excess overburden at borrow pits provided by the Employer	m ³	50		
B201.02	Temporary stockpiling of material provided by the contractor	m ³	1 275		
TOTAL CARRIED TO SUMMARY					

SCHEDULE A: ROADWORKS**SECTION 202**

ITEM	DESCRIPTION	UNIT	QTY	RATE	AMOUNT R
	SERIES 2 : EARTHWORKS				
202	TRENCHING				
202,01	Trench excavations				
202.01.01	Up to 1.0m wide				
202.01.01.01	Up to 1,0m deep	m ³	266		
202.01.01.02	Over 1,0m and up to 1,5m deep	m ³	856		
202.01.02	Up to 2,0m wide				
202.01.02.02	Over 1,0m deep and up to 1,5m deep	m ³	1 366		
202.01.02.03	Over 1,5m deep and up to 2,0m deep	m ³	116		
202.01.02	Up to 3,0m wide				
202.01.02.03	Over 1,5m deep and up to 2,0m deep	m ³			
202.01.02.04	Over 2,0m deep and up to 2,5m deep	m ³	517		
B202.02	Extra over items 202.01, 202.03, 202.04 and 202.09 for excavating in	m ³	225		
202,06	The backfilling of trenches (excluding backfill around the pipe barrel) with material obtained from excavation	m ³	1 252		
202,07	Extra over items 202.06 for using backfill material obtained -				
B202.07.02	from sources provided by the contractor	m ³	243,77		
202,10	Removal of spoil material				
202.10.02	To dumping areas to be provided by contractor	m ³	2 093		
202,12	Extra over item 202.06 for additional compaction of backfill to 93% of mod AASHTO density in road reserves	m ³	634		
TOTAL CARRIED FORWARD					

SCHEDULE A: ROADWORKS**SECTION 202**

ITEM	DESCRIPTION	UNIT	QTY	RATE	AMOUNT R
BROUGHT FORWARD					R -
202,13	Backfilling trenches with soilcrete	m ³	100		
202,15	Reinstatement of bitumen surfaced roads	m ²	181,25		
B202.16	Extra over item 202.01 for backfilling using stabilized material	m ³	320		
TOTAL CARRIED TO SUMMARY					

SCHEDULE A: ROADWORKS

SECTION 203

ITEM	DESCRIPTION	UNIT	QTY	RATE	AMOUNT R
	SERIES 2 : EARTHWORKS				
203	MASS EARTHWORKS				
203.01	Excavation and borrow to fill				
203.01.01	Compacted to 90% of modified AASHTO density	m ³	1 275		
203.02	Extra over item 203.01 for excavating in -				
203.02.01	Intermediate material	m ³	138		
203.02.02	Hard material	m ³	69		
203.02.03	Boulder material class A	m ³	41		
203.02.04	Boulder material class B	m ³	41		
203.03	Excavate and spoil of unsuitable material from existing road				
203.03.01	Soft material	m ³	1 670		
203.03.02	Intermediate material	m ³	152		
203.03.03	Hard material	m ³	75,9		
203.03.04	Boulder material class A	m ³	41,4		
203.03.05	Boulder material class B	m ³	41,4		
203.04	Removal of oversize material	m ³	58		
203.05	Variations in compactive effort (applicable to sub item 203.01.03 and item 203.07)				
203.05.01	Vibratory rollers	m ² .pass	7 000		
203.05.02	Impact rollers	m ² .pass	7 000		
203.07	Three-pass roller compaction				
203.07.01	Vibratory roller	m ² .pass	7 000		
203.07.02	Impact roller	m ² .pass	7 000		
203.08	Preparation and compaction of construction bed material to 90% of modified AASHTO density	m ³	1 205		
203.14	Extra over item 203.01 for borrow material from sources to be supplied by the Contractor	m ³	120		
203.15	Extra over items 203.03 and 203.04 for disposing of spoil material to sites to be provided by the Contractor	m ³	120		
TOTAL CARRIED TO SUMMARY					

SCHEDULE A: ROADWORKS

SECTION 502

ITEM	DESCRIPTION	UNIT	QTY	RATE	AMOUNT R
502	SERIES 5 : DRAINAGE AND EROSION PROTECTION				
	PREFABRICATED CULVERTS AND STORMWATER SEWERS				
502,01	Backfilling with selected excavated material compacted to -				
502.01.01	90% of modified AASHTO density	m ³	756,57		
502.01.02	93% of modified AASHTO density	m ³	496		
502,02	Supplying and laying of concrete pipe culverts (type SC-pipes)				
502.02.01	Class B bedding / Class 50D load				
502.02.01.01	(a) 450mm diameter	m	168		
502.02.01	Class B bedding / Class 100D load				
	(a) 450mm diameter	m	253		
	(b) 525mm diameter	m	40		
	(b) 675mm diameter	m	128		
502,16	Manholes, catchpits, precast inlet and outlet structures and junction boxes complete				
502.16.01	Manholes (H/Duty, 2m deep)	No	25		
502.16.02	Kerb inlets				
502.16.02.01	1.5m length	No	5		
502.16.02.01	3.0m length	No	22		
502.16.03	Precast Inlets and outlets	No.			
502.16.04	Transitions	No.	54		
502.16.05	Junction Boxes	No.	8		
B502.16.07	Level adjustments to manhole covers of existing manholes	No.	5		
502.17	Brick work				
502.17.01	115mm thick	m ²	100		
502.17.02	230mm thick	m ²	250		
502.17.03	345mm thick	m ²	50		
B502.24	Cutting of concrete pipes	No	5		
B502.25	Demolishing and/or removing of structures that cannot be removed by bulldozer, including dumping site fees and an unlimited free-haul distance				
	(a) Reinforced concrete structures	m ³	50		
	(b) Plain concrete, side drain structures, kerbs, brickwork, manholes, cleaning eyes, etc	m ³	50		
	(c) Prefabricated concrete culverts	m	500		
B502.26	Repairing or replacing existing drainage systems	Prov Sum	1	R 50 000,00	R 50 000,00
TOTAL CARRIED FORWARD TO SUMMARY					

SCHEDULE A: ROADWORKS**SECTION 503**

ITEM	DESCRIPTION	UNIT	QTY	RATE	AMOUNT R
	SERIES 5 : DRAINAGE AND EROSION PROTECTION				
503	KERBING AND CHANNELLING				
503,01	Concrete kerbing				
503.01.01	Edge beams Class 20/19 concrete (See drawing STD007 - Sheet 1)	m	953		
503.01.02	Figure 7 semi-mountable kerb (See drawing STD007 - Sheet 1)	m	141		
503.01.03	500mm sloping kerb Class 20/19 concrete (See drawing STD007 - Sheet 1)	m	1 180		
503.01.04	Figure 10 Precast edge restraints (See drawing STD008)	m	1 180		
503,02	Concrete kerbing-channelling combination Class 20/19 concrete				
503.02.01	Figure 3 Barrier Kerb with Cast In-situ Channel (See drawing STD015 - Busbays)	m	186		
503.02.02	Manufacture Kassel Kerbs (as per patented for guidance kerb - Profilbeton), install as per Drawings ICP050-1-BS-01/ICP050-1-BS-03	m	240		
503,03	Transition sections (See drawing STD007 - Sheet 2)				
503.03.01	Semi mountable kerb Fig 7 / Barrier kerb (Fib.g) to edge beam	No	20		
503.03.02	Semi mountable Fig. 7 kerb to 500mm sloping kerb	No	32		
TOTAL CARRIED FORWARD TO SUMMARY					

SCHEDULE A: ROADWORKS**SECTION 601**

ITEM	DESCRIPTION	UNIT	QTY	RATE	AMOUNT R
	SERIES 6 : ROADS AND PARKING AREAS				
601	GRAVEL PAVEMENT LAYERS				
601.01	Preparation and compaction of in situ subgrade material				
601.01.02	Compacted to 93% of modified AASHTO density	m ³	1 593		
601.03	Gravel layers constructed from material obtained from excavations:				
601.03.01	Upper Selected				
601.03.01.03	150mm Upper Selected G6 (C4) material Compacted to 95% of modified AASHTO density	m ³	1 275		
B601.02	Gravel layers constructed from material obtained from for borrow material:				
601.02.01	Subbase BRT Lane				
601.02.01.01	G5 material compacted to 95% of modified AASHTO density	m ³	735		
601.02.02	Subbase Mixed traffic Lane/Bus Stops				
601.02.02.01	G5 (C3) material compacted to 95% of modified AASHTO density	m ³	2 345		
601.06	Extra over Item 601.02 for borrow material from sources to be supplied by the Contractor -				
614.02.01	Subbase Layer BRT Lane , with G5 material compacted to 95% of modified AASHTO density	m ³	735		
614.02.02	Subbase Mixed traffic Lane/Bus Stops with G5 (C3) material compacted to 95% of modified AASHTO density	m ³	2 345		
B601.06	Extra over Item 601.03 for borrow material from sources to be supplied by the Contractor -				
B614.02.03	Upper Selected, with G6 (C4) material Compacted to 95% of modified AASHTO density	m ³	1 275		
TOTAL CARRIED TO SUMMARY					

SCHEDULE A: ROADWORKS**SECTION 602**

ITEM	DESCRIPTION	UNIT	QTY	RATE	AMOUNT R
602	SERIES 6 : ROADS AND PARKING AREAS CRUSHED-STONE PAVEMENT LAYERS				
602,01	Crushed-stone base constructed with material obtained from :				
602.01.01	Commercial sources				
602.01.01.01	150mm layer, G1 material compacted to 88% of apparent density	m ³	753		
602.01.01.01	150mm layer, G2 material compacted to 88% of apparent density	m ³	662		
602.04.01	Extra over subitem 602.01.01.01 for compaction to 88% of apparent density	m ³	425		
TOTAL CARRIED SUMMARY					

SCHEDULE A: ROADWORKS**SECTION 604**

ITEM	DESCRIPTION	UNIT	QTY	RATE	AMOUNT R
604	SERIES 6 : ROADS AND PARKING AREAS				
	STABILISATION				
604,01	Chemical stabilisation, extra over unstabilised compacted layers				
	(b) 150mm thick cement stabilised layer (C3 quality)	m ³	2 345		
	(b) 150mm thick cement stabilised layer (C4 quality)	m ³	1 275		
604,02	Chemical stabilising agent				
604.02.05	Cement (CEM II/32,5N)	t	239		
TOTAL CARRIED FORWARD TO SUMMARY					

SCHEDULE A: ROADWORKS**SECTION 605**

ITEM	DESCRIPTION	UNIT	QTY	RATE	AMOUNT R
605 605,01 605.01.02	SERIES 6 : ROADS AND PARKING AREAS PRIME COAT Prime coat MC-30 cut-back bitumen	1	6 806		
TOTAL CARRIED FORWARD TO SUMMARY					

**CONSTRUCTION OF ROADS AND STORMWATER
SCHEDULE A**

SECTION 606

ITEM	DESCRIPTION	UNIT	QTY	RATE	AMOUNT R
606	SERIES 6 : ROADS AND PARKING AREAS				
	ASPHALT BASE AND SURFACING				
606.02.01.01	Medium grade, 40 mm thick	m2	4 235		
606.02.01.02	Medium grade, 50 mm thick	m2	4 840		
606,05	Tack coat of 30% stable grade emulsion	1	4 991		
TOTAL CARRIED FORWARD					R -

**CONSTRUCTION OF ROADS AND STORMWATER
SCHEDULE A**

SECTION 606

ITEM	DESCRIPTION	UNIT	QTY	RATE	AMOUNT R
TOTAL BROUGHT FORWARD					R -
606,08	Trial sections:				
606.08.02	40 mm thickness	m ²	100		
606.08.03	50 mm thickness	m ²	100		
B606.09	100mm cores in asphalt paving	no	50		
606.10	Saw-cutting of asphalt, asphalt base or paving 40mm deep	m	1 100		
TOTAL CARRIED FORWARD TO SUMMARY					

SCHEDULE A: ROADWORKS**SECTION 609**

ITEM	DESCRIPTION	UNIT	QTY	RATE	AMOUNT R
609	SERIES 6 : ROADS AND PARKING AREAS				
	SEGMENTED PAVING				
609,01	Construction of segmental block paving made from:-				
609.01.01	S-A Blocks 25 Mpa, 60mm thick laid in herringbone pattern (grey)	m ²	10 900		
609.01.02	S-A Blocks 25 Mpa, 60mm thick laid in herringbone pattern (terracotta red)	m ²	926		
609.01.03	S-A Blocks 25 Mpa, 80mm thick laid in herringbone pattern (grey)	m ²	630		
609,03	The construction of edge restraints with:				
609.03.01	Precast concrete (Fig 12 edge restraint) according to SABS 927	m	1 100		
609,04	The lifting of existing segmented paving, loading and transporting to a stockpile site as specified in the project specification.				
609.04.01	Segmented blocks	m ²	411		
609,06	Construction of pedestrian ramps for the disabled (See drawing ICP050-RTD-001)				
		no	74		
B609,07	Resanding of the segmental block pavement on instruction of the Engineer	m ²	10 330		
B609,08	Provision and application of:				
B609.08.01	Ant poison	PC Sum	1	R 30 000,00	R 30 000,00
B609.08.02	Add the Contractor's charges	%	30 000		
B609.08.03	Vegetation destroyer	PC Sum	1	R 20 000,00	R 20 000,00
B609.08.04	Add the Contractor's charges	%	20 000		
TOTAL CARRIED TO SUMMARY					

SCHEDULE A: ROADWORKS**SECTION 612**

ITEM	DESCRIPTION	UNIT	QTY	RATE	AMOUNT R
612	SERIES 6 : ROADS AND PARKING AREAS				
	TRAFFIC SIGNS				
612,01	Sign boards with painted background. Symbols, lettering and borders in engineering-grade retro-reflective material, where the sign board is constructed from:				
612.01.03	Sheet steel (chromadek) with an:				
	(a) Area not exceeding 2 m ²	m ²	6		
	(b) Area exceeding 2 m ² but not 10 m ²	m ²	1		
	(d) Street name board (Refer to CoT Drawing STD018 including fixings)	No	5		
612,02	Extra over item 612.01 for using:				
612.02.02	(a) Background of retro-reflective material of:				
	(i) Engineering grade retro-reflective material (Class 1)	m ²	2		
	(ii) High density grade-reflective material (Class 3)	m ²	2		
	(b) Lettering, symbols, numbers, arrows, emblems and borders of retro-reflective material:				
	(i) High intensity grade (Class 3)	m ²	2		
612,03	Sign supports				
612.03.02	Steel Tubing				
	(a) Steel Tubing (76mm dia x 2.0mm wall thickness)	t	0,439		
	(b) Steel Tubing (100mm dia x 2.0mm wall thickness)	t	0,439		
TOTAL CARRIED FORWARD					

SCHEDULE A: ROADWORKS

SECTION 612

ITEM	DESCRIPTION	UNIT	QTY	RATE	AMOUNT R
BROUGHT FORWARD					R -
612,04	Extra over item 612.03.01 and 612.03.02 for providing:				
612.04.01	Unpainted galvanized steel members	t	8		
612,05	Excavation and backfilling for sign supports	m ³	10		
612,06	Dismantling, storing and re-erecting traffic signs with a surface area of:				
612.06.01	up to 2 m ²	No	100		
612.06.02	over 2 m ² but not exceeding 5 m ²	No	20		
612.06.03	over 5 m ² but not exceeding 10m ²	No	20		
612.06.04	over 10 m ² but not exceeding 15 m ²	No	20		
TOTAL CARRIED FORWARD TO SUMMARY					

SCHEDULE A: ROADWORKS**SECTION 613**

ITEM	DESCRIPTION	UNIT	QTY	RATE	AMOUNT R
613	SERIES 6 : ROADS AND PARKING AREAS				
	TRAFFIC MARKINGS				
613,02	Retro-reflective road-marking paint				
613.03	Proprietary brand plastic road-marking material (Thermo Plastic Paint)				
613.03.01	White lines (broken or unbroken):				
	(a) 100 mm wide	km	1,40		
	(b) 150 mm wide	km	0,6		
	(c) 200 mm wide	km	0,80		
	(d) 300 mm wide	km	0,20		
613.03.02	Yellow lines (broken or unbroken) 100mm wide	km	1,00		
613.03.03	White lettering and symbols	m ²	68		
613.03.04	Yellow lettering and symbols	m ²	34		
613.03.05	Traffic-island markings (any colour)	m ²	0		
613,05	Road Studs (SANS approved)				
613.05.01	Single sided road stud	No.			
613.05.02	Double sided road stud	No.	30		
613.05.03	Non-reflective road stud	No.			
TOTAL CARRIED FORWARD					

SCHEDULE A: ROADWORKS

SECTION 613

ITEM	DESCRIPTION	UNIT	QTY	RATE	AMOUNT R
TOTAL BROUGHT FORWARD					R -
613,06	Setting out and the pre-marking of lines (excluding traffic-island markings, lettering and symbols)	km	0,70		
TOTAL CARRIED TO SUMMARY					

TSHWANE BUS RAPID TRANSIT (BRT) INFRASTRUCTURE ON LINE 3: PRINCESS PARK STREET AND REFURBISHMENT OF STREET LIGHTING ON WF NKOMO STREET**PRICING SCHEDULE : ELECTRICAL WORKS**

Item	Description	Unit	Qty	Rate	Amount R
1.7	SWITCHING COST Liaising with Tshwane for isolation and disconnections, from supply points.				
1.7.1	Connection and reconnection to Tshwane supply points	L/Sum	1		
1.8	TESTING AND COMMISSIONING				
1.8.1	Test and commission complete installation, with three copies of test results and certificates	L/Sum	1		
1.9	MANUFACTURER'S WORKSHOP DRAWINGS				
1.9.1	Provision of manufacturer's workshop drawings and technical information including data sheets and lighting distribution drawings for approval by the Engineer before ordering	L/Sum	1		
1.10	CERTIFICATES OF COMPLIANCE				
1.10.1	Final commissioning and testing in the presence of the Electrical Engineer, and provision of Certificates of Compliance	L/Sum	1		
TOTAL CARRIED FORWARD					

PRICING SCHEDULE : ELECTRICAL WORKS

ITEM	DESCRIPTION	UNIT	QTY	RATE	AMOUNT R
TOTAL BROUGHT FORWARD					
2.1	RETICULATION SYSTEM Supply 12 Way LV kiosk as per CoT specifications, complete with plinth and electronic access control system as per City of Tshwane specifications				
2.1.1	Supply	No	2		
2.1.2	Install	No	2		
2.2	LOW VOLTAGE CABLES 600/1000V PVC/ECC Aluminium cable burried directly into ground, drawn in sleeves when it crosses roads. Cable terminations to include glands, shrouds, lugs, connections and commissioning per cable end NOTE: Notwithstanding the fact that the lengths of cables as given in the Bill of Quantities have been measured from scaled drawings, the contractor shall check such lengths on site before ordering the cable as he/she will not be paid for excess cable after the completion of the service. Any allowance for off-cuts shall be made in the unit rates. The final measurements shall be based on the nett route length of the cable concerned.				
2.2.1	25 mm² PVC AL LV 4 Core ECC Armoured Cable				
2.2.1.1	Supply	m	1800		
2.2.1.2	Install	m	1800		
2.2.1.3	Termination	No	90		
2.2.1.4	Through Joint	No	227		
2.2.2	2.5 mm² PVC CU LV 3 Core SWA Armoured Cable				
2.2.2.1	Supply	m	1000		
2.2.2.2	Install	m	1000		
2.2.2.3	Termination	No	90		
2.2.3	70mm² PVC AL LV 4 Core ECC Armoured Cable				
2.2.3.1	Supply	m	500		
2.2.3.2	Install	m	500		
2.2.3.3	Termination	No	2		
2.2.3.4	Through Joint	No	10		
2.3	ENCASING LV CABLE IN SOILCRETE Encasing electrical cabling and other services in a 200mm X300mm trench using 20MPa soilcrete				
2.2.3.1	Supply	m ³	100		
2.2.3.2	Install	m ³	100		
2.4	EXCAVATIONS Excavations for cable and sleeve trench including temporary support of sides, keeping excavation dry, bedding material, backfilling, soilcrete and compacting as specified. Where required, the removal of excess material from site shall be included in the rates below				
2.4.1	Excavation in soft material	m ³	576		

3. Line 3_Interim operation - Unpriced (004)

2.4.2	Excavation in intermediate material	m ³	172,8		
2.4.3	Excavation in hard rock	m ³	172,8		
2.4.4	Extra over for using backfill material obtained from sources provided by the Contractor	m ³	172,8		
2.4.5	Bedding under and filling around cables comprising sifted sand and soilcrete	m ³	1094,4		
2.4.6	Road crossing: Excavations in the existing roads to install sleeves (road width 16m). Contractor to provide rate per crossing	each	10		
2.5	SLEEVE PIPES Supply and install cable sleeves and associated accessories and manholes as specified				
2.5.1	160mmØ Flexible uPVC underground sleeves suitable for electrical cables to be cast into concrete encasement				
2.5.1.1	Supply	m	700		
2.5.1.2	Install	m	700		
2.5.2	PVC Warning Tape				
2.5.2.1	Supply and install PVC electrical danger tape in trench above cables or sleeves	m	1890		
2.5.3	Draw Wire				
2.5.3.1	Supply and install draw wire or 6 mm diameter nylon draw cord in sleeve & sleeve end as required	m	700		
2.6	MANHOLES				
2.6.1	Provide 600X600X600 Deep cable sleeves manhole, complete with steel covers.	No	4		
2.6.2	Provide 1000x1000x1000 deep cable Electrical sleeves manhole, complete with covers	No	16		
TOTAL CARRIED FORWARD					

PRICING SCHEDULE : ELECTRICAL WORKS

ITEM	DESCRIPTION	UNIT	QTY	RATE	AMOUNT R
TOTAL BROUGHT FORWARD					
3.1	LIGHT FITTINGS				
3.1.1	LED 48/162W (N5248A1G7D)				
3.1.1.1	Supply	No	45		
3.1.1.2	Install	No	45		
3.1.2	LED 16/54W N5244A1G7D				
3.1.2.1	Supply	No	45		
3.2.2.2	Install	No	45		
3.2	STREET LIGHT POLES All street light poles are to comply with the CoT specifications. The cost of the street light poles, mounting flange, spigots, wiring and all other accessories, band strapping of access holes, trenching and backfilling required for the planting of the street light poles are all inclusive in the below rates				
3.2.1	TAMPER PROOF TORX TOOL M6				
3.2.1.1	Supply	No	0		
3.2.1.2	Install	No	0		
3.2.2	10.5m FLANGE GALVANISED STEEL POLE				
3.2.2.1	Supply	No	45		
3.2.2.2	Install	No	45		
3.2.3	1.5m STUBBY				
3.2.3.1	Supply	No	45		
3.2.3.2	Install	No	45		
3.2.4	SINGLE SPIGOT 500mm x 42				
3.2.4.1	Supply	No	45		
3.2.4.2	Install	No	45		
3.2.5	DOUBLE SPIGOT				
3.2.5.1	Supply	No	2		
3.2.5.2	Install	No	2		
3.2.6	PEDESTRIAN SIDE SPIGOT 500mm x 42				
3.2.6.1	Supply	No	45		
3.2.6.2	Install	No	45		
3.3	EXISTING STREET LIGHTING				
3.3.1	Pre- arrangements & Isolation of the power supply, disconnection of cables, removal of the luminaire, outreach arm and pole complete. Pole length: 11,0m Outreach 3m	Item	25		
3.3.2	Remove old existing luminaires complete (including protecting and transport to Tshwane depot)	Item	25		
3.3.3	Temporarily store the removed poles, luminaires and outreach arms complete, in a secured area	Sum	1		
TOTAL CARRIED FORWARD					

PRICING SCHEDULE : ELECTRICAL WORKS

ITEM	DESCRIPTION	UNIT	QTY	RATE	AMOUNT R
TOTAL BROUGHT FORWARD					
4.1	TELE-MANAGEMENT SYSTEM				
4.1.1	Supply and Install tele-management units in each luminaire	ea	90		
4.1.2	Supply and Install tele-management Sector controllers	ea	1		
4.1.3	Supply and install GSM modems with all accessories required for full	ea	1		
4.1.4	Supply and install at the City of Tshwane Electrical Department a new PC, as specified. complete with all software and hardware required, to ensure full	Item	1		
4.1.5	Program and commission and hand-over in full operating condition the specified Tele-management installation and system	L/Sum	1		
4.1.6	Provide complete training, with training material and training manuals to City of Tshwane Electrical Department nersonal in respect of the operation and	L/Sum	1		
TOTAL CARRIED FORWARD					

PRICING SCHEDULE : ELECTRICAL WORKS

ITEM	DESCRIPTION	UNIT	QTY	RATE	AMOUNT R
TOTAL BROUGHT FORWARD					
5.1	EXCAVATIONS (Fibre excavations to be separate with electrical ones)				
5.1.1	Excavations and sleeve trench including temporary support of sides, keeping Excavation in soft material	m ³	288		
5.1.1	Excavation in intermediate material	m ³	86,4		
5.1.2	Excavation in hard rock	m ³	86,4		
5.1.3	Extra over for using backfill material obtained from sources provided by the	m ³	86,4		
5.1.4	Bedding under and filling around cables comprising sifted sand and soilcrete	m ³	547,2		
5.1.5	Road crossing: Excavations in the existing roads to install sleeves (road	each	10		
5.2	SLEEVE PIPES				
5.2.1	Supply and install sleeves and associated accessories and manholes as 160mmØ Flexible uPVC underground sleeves suitable for fibre cables				
5.2.1.1	Supply	m	700		
5.2.1.1	Install	m	700		
5.2.2	PVC Warning Tape				
5.2.2.1	Supply and install PVC electrical danger tape in trench above cables or sleeves	m	100		
5.3.1	Draw Wire				
5.3.1.1	Supply and install draw wire or 6 mm diameter nylon draw cord in sleeve & sleeve end as required	m	700		
5.4	MANHOLES				
5.4.1	Provide 800x800x1000 Deep cable sleeves manhole, complete with steel covers	No	14		
5.4.2	Provide 1000x1000x1000 deep cable Electrical sleeves manhole, complete	No	2		
TOTAL CARRIED FORWARD					

PRICING SCHEDULE : ELECTRICAL WORKS

ITEM	DESCRIPTION	UNIT	QTY	RATE	AMOUNT R
TOTAL BROUGHT FORWARD					
6.1	LIGHT FITTINGS Supply and install new light fittings to existing light poles (contractor's rates				
6.1.1	LED 48/162W (N5248A1G7D)				
6.1.1.1	Supply	No	100		
6.1.1.2	Install	No	100		
6.1.2	LED 16/54W N5244A1G7D				
6.1.2.1	Supply	No	10		
6.2.2.2	Install	No	10		
6.2	STREET LIGHT POLES All street light poles are to comply with the CoT specifications. The cost of				
6.2.1	TAMPER PROOF TORX TOOL M6				
6.2.1.1	Supply	No	5		
6.2.1.2	Install	No	5		
6.2.2	10.5m FLANGE GALVANISED STEEL POLE				
6.2.2.1	Supply	No	20		
6.2.2.2	Install	No	20		
6.2.3	1.5m STUBBY				
6.2.3.1	Supply	No	10		
6.2.3.2	Install	No	10		
6.2.4	SINGLE SPIGOT 3000mm x 42				
6.2.4.1	Supply	No	30		
6.2.4.2	Install	No	30		
6.2.5	DOUBLE SPIGOT				
6.2.5.1	Supply	No	5		
6.2.5.2	Install	No	5		
6.2.6	PEDESTRIAN SIDE SPIGOT 500mm x 42				
6.2.6.1	Supply	No	10		
6.2.6.2	Install	No	10		
6.3	CABLES Supply and installation of ABC overhead cables. Rate to include accessories required to install the cables to the existing poles.				
6.3.1	25 mm² ABC 1 phase + 25 mm² insulated neutral				
6.3.1.1	Supply	No	2000		
6.3.1.2	Install	No	2000		
6.3.1.3	Termination	No	100		
6.3.2	2.5 mm² PVC CU LV 3 Core SWA Armoured Cable				
6.3.2.1	Supply	m	1000		
6.3.2.2	Install	m	1000		
6.3.2.3	Termination	No	200		
6.4	EXISTING STREET LIGHTING Pre- arrangements & Isolation of the power supply, disconnection of cables,	Item			
6.4.1	removal of the luminaire, outreach arm and pole complete. Pole length: 11.0m Outreach 3m		30		
6.4.2	Remove old existing luminaires complete (including,protecting and transport to Tshwane depot)	Item	30		
6.4.3	Temporarily store the removed poles, luminaires and outreach arms complete, in a secured area	L/Sum	1		
TOTAL CARRIED FORWARD					

PRICING SCHEDULE : ELECTRICAL WORKS

ITEM	DESCRIPTION	UNIT	QTY	RATE	AMOUNT R
TOTAL BROUGHT FORWARD					
PROVISIONAL AMOUNTS					
7.1	Tshwane Costs				
7.1.1	Relocation of existing Electrical Services and connecting into the existing supply	PC Sum	1	R200 000,00	R200 000,00
7.1.2	Profit and Handling on item 5.1.1 above (State % in Labour Rate Column)	%			
7.1.3	Additional pipe crossings required by Tshwane	PC Sum	1	R100 000,00	R100 000,00
7.1.4	Profit and Handling on item 5.1.3 above (State % in Labour Rate Column)	%			
7.2	Any additional work which the tenderer deems necessary specific to this equipment to successfully complete this section. (Tenderer to qualify items in cover letter)	L/Sum	1		
TOTAL CARRIED TO SUMMARY PAGE					

SCHEDULE A: ROADWORKS**SECTION 903**

ITEM	DESCRIPTION	UNIT	QTY	RATE	
903	SERIES 9 : QUALITY CONTROL TESTING				
903,06	Other special tests required by the Engineer				
903.06.01	Cost of testing	PC Sum	1	R 900 000,00	R 900 000,00
903.06.02	Charge on prime sum	%	900 000		
TOTAL CARRIED TO SUMMARY					R 900 000,00

SUMMARY OF SECTIONS

SERIES	DESCRIPTION	AMOUNT R
SERIES 0	GENERAL	
001	GENERAL REQUIREMENTS AND CHARGES	
002	ENGINEER'S ACCOMMODATION	
SERIES 1	ANCILLARY WORKS	
101	SITE CLEARANCE	
102	ACCOMMODATION OF TRAFFIC	
103	OVERHAUL	
106	SERVICE DUCTS	
B107	DAYWORKS	
SERIES 2	EARTHWORKS	
202	TRENCHING	
203	MASS EARTHWORKS	
SERIES 5	DRAINAGE AND EROSION PROTECTION	
501	SUBSURFACE DRAINS AND DRAINAGE BLANKETS	
502	PRERABRICATED CULVERT AND STORMWATER SEWERS	
503	KERBING AND CHANNELLING	
SERIES 6	ROADS AND PARKING AREAS	
601	GRAVEL PAVEMENT LAYERS	
602	CRUSHED-STONE PAVEMENT LAYERS	
604	STABILISATION	
605	PRIME COAT	
606	ASPHALT BASE AND SURFACING	
609	SEGMENTED PAVING	
611	GUARDRAILS	
612	TRAFFIC SIGNS	
613	TRAFFIC MARKINGS	
TOTAL CARRIED FORWARD		

SUMMARY OF SECTIONS

SERIES	DESCRIPTION	AMOUNT R
TOTAL CARRIED FORWARD		
SERIES 8	SPECIFIC WORKS	
B810	SPECIFIC WORKS - STREET LIGHTING	
SERIES 9	QUALITY CONTROL	
903	TESTING	
	TOTAL	

CALCULATION OF THE TENDER SUM	
TOTAL OF SCHEDULED PRICES	
ADD 10% FOR CONTINGENCIES	
SUBTOTAL	
ADD 15% VAT	
CONTRACT PRICE CARRIED FORWARD TO FORM OF OFFER	

**ROADS AND TRANSPORT DEPARTMENT
IRPT SPECIALISED UNIT**



TENDER REFERENCE: RTD 04 2023/24

**INTEGRATED RAPID PUBLIC TRANSPORT NETWORK (IRPTN)
PROJECT:
UPGRADING OF IRPTN LINE 3 INTERIM OPERATIONS: PRINCE'S
PARK AVENUE AND BUS STOPS/BAYS ALONG WF NKOMO
STREET**

VOLUME 3 of 3

A Tender for Category 7CE or higher CIDB registered Contractors

ISSUED BY:	PREPARED BY:
The Group Head: Roads and Transport <u>IRPTN DIVISION</u> PO Box 1409 PRETORIA 0001 Tel: 012 358-1064	Imbawula Civil Projects (Pty) Ltd (Pty) Ltd PLOT 70, 1463 TIENIE STREET ANDEON A/H PRETORIA WEST 0183 Tel: 012 372 3807

Registered Name of Tenderer:	
Trading Name of Tenderer:	
Registration No. of Entity:	
Contact Person:	CoT Vendor No:
Tel. No:	E-Mail Address:
Cell No:	Fax No:
CIDB CRS Number (s):	

VOLUME 1 OF 3

- PART T1** TENDERING PROCEDURES
- PART T2** RETURNABLE DOCUMENTS
- PART T3** SUBCONTRACTING PROCEDURES
- PART C1** AGREEMENTS AND CONTRACT DATA

VOLUME 2 OF 3

- PART C2** PRICING DATA

VOLUME 3 OF 3

- PART C3** SCOPE OF WORK
- PART C4** SITE INFORMATION
- PART C5** ANNEXURES

PART C3: SCOPE OF WORK

PART C3: SCOPE OF WORKS

Table of Contents

C3.1	DESCRIPTION OF THE WORKS
C3.1.1	Employer's objectives
C3.1.2	Overview of the works
C3.1.3	Extent of the Works
C3.2	ENGINEERING
C3.2.1	Design Services and Activity Matrix
C3.2.2	Employer's Design
C3.2.3	Drawings
C3.2.4	Design Procedures
C3.2.5	Laboratories
C3.2.6	Accommodation of traffic
C3.2.7	Contractor's camp site and office accommodation for supervisory staff
C3.2.8	Temporary stock pile site(s)
C3.2.9	Construction Method Statement
C3.3	PROCUREMENT
C3.3.1	Preferential procurement procedures
C3.3.2	Subcontracting
C3.4	CONSTRUCTION
C3.4.1	Works specifications
C3.4.2	Plant and materials
C3.4.3	Construction equipment
C3.4.4	Existing services
C3.4.5	Site establishment
C3.4.6	Permits and way leaves
C3.4.7	Inspection of adjoining properties
C3.4.8	Survey control and setting out of the works
C3.5	MANAGEMENT
C3.5.1	Management of the works
C3.5.2	Environment
C3.5.3	Health and Safety

C3.1 DESCRIPTION OF THE WORKS

C3.1.1 Employer's objectives

The employer seeks to upgrade the existing road infrastructure on Prince's Park Avenue such that it accommodates the introduction of public transport buses. The introduction of public transport busses increases the volume of traffic on the existing road infrastructure which motivates the need to upgrade the existing infrastructure by means of widening the existing road. Since A Re Yeng's implementation, the system has been facing issues that have slowed its implementation and its re-structuring role. The City thus identified a need for change in the way the system is planned, budgeted for and implemented. Research undertaken on system performance as well as grant funding allocation changes resulted in the development of the Optimisation Strategy.

The goals of the Optimisation Strategy can therefore be summarised as:

- Implement an efficient system to the benefit of the commuter, the operator(s), and the City.
- Implement a cost-effective system in terms of future roll-out options.
- Implement a system that generates sufficient income over the medium term to comply with the NDoT cost recovery Key Performance Indicators.
- Optimise implementation for each phase in accordance with the above principles.

In reference to the Traffic Engineering Report the following infrastructure capacity development is required for Line 3 – Section 1 for various stages of Operations as per the Optimization Strategy:

- Implementation of capacity improvement schemes at Nana Sita and Princes Park in the form of bus lanes
- Immediate Infrastructure Improvements for the rest of Line 3, Section 1 as outlined in Concept and Viability Report (i.e. sidewalks, bus stops, bus shelters and wayfinding systems to be implemented)

This tender is for the construction of new lanes on Prince's Park Avenue as part of the Optimisation Strategy, Immediate Operations including the upgrading of existing bus bays and bus stops and the protection or relocation of services on Prince's Park Avenue. It also includes the upgrading of electrical infrastructure on Prince's Park and parts of WF Nkomo Street.

Prince's Park Avenue is approximately 0.520 km in length and includes the following intersections:

- i. Prince's Park Avenue and Nana Sita Street West
- ii. Prince's Park Avenue and Nana Sita Street East
- iii. Prince's Park Avenue and Francis Baard Street
- iv. Prince's Park Avenue and Pretorius Street
- v. Prince's Park Avenue and WF Nkomo Street

A major requirement of this tender is that the successful tenderer will have to work closely with the following subcontractors in order to complete the works:

- (i) Specialised subcontractors

The following specialised services will be done by external Service Providers. Provisional Sums has been provided for in the Pricing Schedule (Section 001).

- Relocation and protection of Fibre Optic Cables.

- Traffic signalling for the phase design and implementation.

C3.1.2 Overview of the works

The works package comprises of:

- Removing the existing layerworks on Prince’s Park Avenue
- Reusing some of the material obtained from the box cutting
- Road widening which may include removing and relocation of trees, bollards and park furniture
- Relocation and protection of underground services
- Upgrading of the existing stormwater network
- Upgrading of existing bus bays and bus stops
- The upgrading of the existing sidewalks to support Non-Motorized Transport (NMT).
- Accommodation of traffic during the construction stage
- Upgrading of the existing street lights on Princess’s Park Avenue
- Replacement of non-working street lights along Nkomo Street

The work to be performed under this contract comprises of the Construction of BRT Infrastructure on Line 3 – Section 1 (CBD To Atteridgeville). This contract consists of one document for CIDB grading 7CE or higher.

The longitudinal and latitudinal coordinates of the proposed existing road capacity improvements that is located in the Central Business District of City of Tshwane are as follows:

Road Name	Road Length	Start Point	End Point
Princess Park	520 m	25°45'5.39"S; 28°10'43.17"E	25°44'49.69"S; 28°10'41.91"E

In the outbound direction (CBD to Atteridgeville), seven bus stops are proposed over the length of the corridor at an average spacing of 800m between stops, of which one is a new stop. Likewise, in the return direction, nine bus stops are proposed over the length of the corridor at an average spacing of 800m between stops, of which two are new stops.

Table 3.1.2.1 - Seven (7) Stops Outbound direction as tabled below:

Stop Name	Street Name	Next Cross Street	Latitude	Longitude	Type of Bus Stop
1	WF Nkomo Street	D.F Malan Drive	25°44'50.48"S	28°10'33.41"E	Kerb-Side
4	WF Nkomo Street	Ketjen Street	25°44'53.08"S	28° 9'57.22"E	Embayment
6	WF Nkomo Street	Zeiler Street	25°44'54.96"S	28° 9'28.26"E	Kerb-Side
9	WF Nkomo Street	Court Street	25°44'56.65"S	28° 9'3.33"E	Kerb-Side
11	WF Nkomo Street	Lievaart Street	25°44'58.16"S	28° 8'39.98"E	Kerb-Side
13	WF Nkomo Street	Transoranje Road	25°45'0.16"S	28° 8'11.36"E	Embayment
Proposed A	Transoranje Road	Van Dalsen Street	25°45'16.37"S	28° 8'0.90"E	Embayment

Table 3.1.2.2 - Nine (9) Stops Inbound direction as tabled below:

Stop Name	Street Name	Next Cross Street	Latitude	Longitude	Type of Bus Stop
45 R	Quagga Road (R55)	Transoranje Road	25°45'50.84"S	28° 7'20.71"E	Kerb-Side
Proposed E	Transoranje Road	Van Dalsen Street	25°45'39.60"S	28° 7'58.29"E	Kerb-Side
Proposed F	Transoranje Road	WF Nkomo Street	25°45'13.53"S	28° 7'59.87"E	Embayment
46 R	WF Nkomo Street	Chroom Street	25°45'0.09"S	28° 8'2.06"E	Embayment
49 R	WF Nkomo Street	Lievaart Street	25°44'57.84"S	28° 8'35.41"E	Embayment
52 R	WF Nkomo Street	Rose Etta Street	25°44'56.06"S	28° 9'3.31"E	Kerb-Side
55 R	WF Nkomo Street	Maltzan Street	25°44'54.33"S	28° 9'28.59"E	Kerb-Side
58 R	WF Nkomo Street	Retief Street	25°44'51.93"S	28° 10'3.25"E	Kerb-Side
61 R	WF Nkomo Street	Cowie Street	25°44'49.90"S	28° 10'33.12"E	Kerb-Side

The Scope of Works is explained in more detail in the Specific engineering details of the works as included in Section C3.2: Engineering.

C3.1.3 Extent of the Works

C3.1.3.1 Preparation & Ancillary Works

- (a) The establishment on site, including the provision of facilities for the engineer and material testing laboratory facility
- (b) The supply of plant, labour, tools, equipment and materials necessary to complete the work.
- (c) Setting out of the Works by means of benchmarks provided by the Employer.
- (d) Before any works can commence the contractor must relocate/protect all existing services and associated infrastructure, and only then can the proposed road deviations be constructed which are mainly situated adjacent to the new road reserve boundary.
- (e) Accommodation of traffic during the construction stage, includes the erection of temporary road signs, STOP/GO controls and traffic signals and other traffic control devices and the provision of access to residents and businesses adjacent to the road.

C3.1.3.2 Road Works

The main items of work to be undertaken are the following but in no particular order:

- (a) Construction of mass earthworks.
- (b) Construction of gravel pavement layers, including selected layers.
- (c) Construction of stabilised subbase layer.
- (d) Construction of a crushed stone (G1) and continuously graded asphalt base layers.
- (e) Construction of asphalt wearing courses.

- (f) Construction of precast pipe culverts.
- (g) Extension, repairs to inlet and outlet structures of existing drainage culverts where required.
- (h) Installation of kerbing and channelling.
- (i) Construction of segmental block paving on the sidewalks including removal and disposal where required of old material.
- (j) Road markings and road studs as well as the supply and erection of road signs.
- (k) Testing of materials.
- (l) Procurement of road building materials from commercial sources.
- (m) Installation of street lighting by selected sub-contractor and temporary traffic signals.
- (n) Installation of street furniture on sidewalks.
- (o) Landscaping along the route by selected sub-contractor.

C3.1.3.3 Electrical Works: Street lighting and relocation/protection of electrical services

The electrical works along Princess Park Avenue comprise the supply, delivery, installation, testing, commissioning, handing over in working order and maintaining for the Defects Liability Period of the proposed street lighting system along with the works related to the existing supply network (i.e., any relocation of services). This section of work will be executed by a subcontractor to be appointed by the main contractor. Additional to the scope of above, the contractor will be required to replace the non-working light fittings along Nkomo street and as well the areas where the street poles have been affected. The stolen or areas with no cables will be required to be replaced with new cables.

C3.1.3.4 Relocation/ protection of Services

This contract includes certain work relating to the relocation and/or protection of all other existing services that may be affected by the construction of the works.

The following affected services have been identified:

- Water reticulation pipes (Main Contractor's responsibility).
- Electrical (Eskom and/or municipal electrical department).
- Telkom (Telkom responsibility)
- Fibre optic Cable (Relevant specialist subcontractor which will be determined on site is responsible)
- Unknown Services (Responsibility to be determined on site)

It is anticipated that this portion of the work will be executed by specialist subcontractors provided by the various service providers.

C3.1.3.5 Traffic Signalization

The traffic signalization of intersections comprises of the supply, delivery, installation, testing, commissioning, handing over in working order and maintaining for the Defects Liability Period.

This portion of the work will be executed by a selected specialist sub-contractor. However, certain civil works will be carried out by the principal contractor.

C3.1.3.6 Landscaping

Before any construction commences, all designated plants must be relocated to designated off-site areas to be determined by the client. This portion of the work will be executed by a selected specialist

sub-contractor.

C3.1.3.8 Quality Control

Quality control on the site shall comprise the contractor's quality system in conjunction with the engineer's quality system and procedures, which will be agreed upon on the commencement of the contract.

C3.1.3.9 Wayleaves

The Engineer has obtained CoT wayleave approval for the design. In the event of any revisions, updates or new wayleaves being required, the contractor shall be responsible for obtaining a new CoT wayleave. A lump sum pay item has been provided for these possible events, to cover the contractor's costs.

C3.1.3.10 Geotechnical Information

A Materials Investigation and Utilization Reporting containing results of the test pit profiles and laboratory testing can be made available to the successful tenderer on request. It is the contractor's responsibility to ensure that all material used on site is tested and meets all the requirements as stated in the design and by the engineer.

C3.2 ENGINEERING

C3.2.1 Design Services and Activity Matrix

The designs envisaged for this Contract are detailed in table below together with responsible agent assigned, who shall remain liable for all design requirements unless revised in writing by the Employer.

Service / Activity	Responsible Agent
Concept and Feasibility	Imbawula Civil Projects (Pty) Ltd (Pty) Ltd (Pty) Ltd
Specifications	City of Tshwane (CoT)
Final Engineering Design	Imbawula Civil Projects (Pty) Ltd (Pty) Ltd (Pty) Ltd
Tender Documentation & Drawings	Imbawula Civil Projects (Pty) Ltd (Pty) Ltd (Pty) Ltd
Invite Tenders for main contract	City of Tshwane (CoT)
Site Inspection for main contract	City of Tshwane (CoT) / Imbawula Civil Projects (Pty) Ltd (Pty) Ltd (Pty) Ltd
Tender Evaluation for main contract	City of Tshwane (CoT)
Appoint Contractor for main contract	City of Tshwane (CoT)
Construction of Permanent Works	Contractor
Design and Construction of Temporary Works	Contractor
Full-time Site Supervision	Imbawula Civil Projects (Pty) Ltd (Pty) Ltd (Pty) Ltd
Preparation of "As Built" drawings	Contractor / Imbawula Civil Projects (Pty) Ltd (Pty) Ltd (Pty) Ltd

C3.2.2 Employer's Design

The extent of the design is discussed under Part C3.1: Description of the Works in this document. Additional engineering details related to the design are provided below.

C3.2.2.1 Road Geometry

As per the drawings

C3.2.2.2 Pavement Designs

C3.2.2.2.1 New layerworks for mixed traffic lanes

The new layerworks for mixed traffic lanes will have the following pavement structure:

- 40mm Continuously graded asphalt
- 150mm G2 base
- 150mm C3 subbase
- 150mm C4 upper selected
- 150mm subgrade

C3.2.2.2.2 New for the new BRT lanes

The layerworks for the new BRT Lanes will have the following pavement structure:

- 50mm Continuously graded asphalt
- 150mm G1 base
- 300mm C3 subbase
- 150mm G5 upper selected
- 150mm subgrade

C3.2.2.3 Traffic Signals

Traffic signals will be installed as a separate contract by a selected specialist sub-contractor.

C3.2.2.4 Electrical Services (Street lighting and Relocation/ Protection of Electrical Services)

Street lighting and Relocation

The existing street lighting will be removed and replaced by a new system. This will be carried out by a specialist sub-contractor.

Protection of Electrical Services

According to wayleave responses the following will require protection or relocation

- Service Connection Feeder Cable;
- MV Cable Capped in Ground Location;
- MV Cable (MF Location);
- MV Cable (RF Location)
- Service Connection Feeder Cable

C3.2.2.5 Relocation/ protection of services (excluding Relocation/Protection of Electrical Services)

The relocation/ protection of services includes most of the following services:

- Water reticulation pipes.
- Electrical.
- Telkom
- Fibre optic Cable
- Unknown Services

and will have to be carried out in close co-operation with the relevant service owner by specialist subcontractors. For many of the services ducts will have to be inserted for relocation of the temporary services to their final positions. These include electrical, traffic signals, irrigation to plants, etc. These ducts shall be inspected and tested prior to their acceptance.

C3.2.2.6 non-Motorized transport facilities

Non-motorized facilities form an important part of the works and will detailed on the construction drawings.

C3.2.2.7 Stormwater drainage

Construction of stormwater infrastructure will be done within the road reserve of existing Prince's Park Avenue

During construction it will be essential to maintain stormwater flow through the contributing road and external catchments. Before installation of pipes and construction of stormwater infrastructure takes place, all positions and levels must be verified on site.

The stormwater drainage on Prince's Park Avenue can be summarized as follows:

- Pipe culverts
The existing stormwater pipes would require extending.

- Structures
 All existing kerb inlets, junction boxes, grid inlets, etc. will have to be removed and re-constructed to accommodate the road widening.

C3.2.2.8 Geotechnical Information

The project limit falls within the Transvaal System and more specific the Pretoria Series. The group is primarily underlain by quartzite, shale, hornfels, calcareous layers and agglomerate. It can be expected that there are silty clayey deposits in the flood plains and stream beds of the rivers (streams) crossing the area

The geotechnic report can be made available to the tenderers on request.

C3.2.2.9 Landscaping

If required, landscaping will be carried out as a separate subcontract by a specialist selected contractor. This will comprise basically two phases, namely the initial relocation of trees to an off-site location and the final landscaping of the route at the end of the contract.

C3.2.3 Drawings

The drawings prepared by the Employer’s Agent and which are applicable to this Contract are herewith listed and attached to Volume 3 (C5 – Annexures):

In general, the tender drawings display the proposed upgrades including new lanes which are part of the road widening that is required for this project together with typical cross-sections and pavement designs. The Employer will provide the successful tenderer with one paper copy of the necessary construction drawings on the Commencement Date and an electronic format of the drawings so that he can make his own copies.

This drawing list will be used herewith will be used in conjunction with the City of Tshwane Standard Construction Details and the **Standard Specifications for Municipal Civil Engineering Works, Third Edition 2005** (download link <https://wayleave.tshwane.gov.za/page/details/3/?page=1>)

CIVIL DRAWINGS	
Tender Drawings	Drawing Description
ICP050-LP-001	Layout plan for Prince's Park Avenue from CH 0+000 to CH 0+500
ICP050-1-LP-BS-001	Layout plan for Bus Stop 61R & No.1
ICP050-1-LP-BS-002	Layout plan for Bus Stop 58R
ICP050-1-LP-BS-003	Layout plan for Bus Stop No.4
ICP050-1-LP-BS-004	Layout plan for Bus Stop 55R
ICP050-1-LP-BS-005	Layout plan for Bus Stop No.6
ICP050-1-LP-BS-006	Layout plan for Bus Stop 52R & No.9
ICP050-1-LP-BS-007	Layout plan for Bus Stop No.11
ICP050-1-LP-BS-008	Layout plan for Bus Bay 49R
ICP050-1-LP-BS-009	Layout plan for Bus Bay No.13
ICP050-1-LP-BS-010	Layout plan for Bus Bay 46R

CIVIL DRAWINGS	
Tender Drawings	Drawing Description
ICP050-1-LP-BS-011	Layout plan for New Proposed Bus Bay F
ICP050-1-LP-BS-012	Layout plan for New Proposed Bus Bay A
ICP050-1-SLS-001	Longitudinal Profile & Layout Plan for Stormwater in Nana Sita Street
ICP050-1-SLS-002	Longitudinal Profile & Layout Plan for Stormwater in Francis Baard Street
ICP050-1-SLS-003	Longitudinal Profile & Layout Plan for Stormwater in Pretorious Street
ICP050-1-SLS-004	Longitudinal Profile & Layout Plan for Stormwater in WF Nkomo Street
ICP050-1-SWL-001	Stormwater Catchment Layout
ICP050-RM-001	Road Marking Layout plan from CH 0+000 to CH 0+500
ICP050-RS-001	Road Signage Layout plan from CH 0+000 to CH 0+500
ICP050-1-TA-001	Traffic Accommodation Plan
ICP050-1-DET-001	Detection Survey
ICP050-1-XS-001	Road Cross Section from CH0+000 to CH0+380
ICP050-1-XS-002	Road Cross Section from CH0+400 to CH0+502.6
ICP050-1-DET-002	Detection Survey
ICP050-1-DET-003	Detection Survey
ICP050-1-DET-004	Detection Survey

ELECTRICAL DRAWINGS	
Tender Drawings	Drawing Description
ICP050-1-SL-001	Street lighting Layout
ICP050-1-SL-002	Street lighting Layout
ICP050-1-SL-003	Street lighting Layout
ICP050-1-SL-004	Street lighting Layout
ICP050-1-SL-005	Street lighting Layout
ICP050-1-SL-006	Street lighting Layout

C3.2.4 Design Procedures

All designs and modifications thereto shall be communicated in writing and the Contractor and Engineer shall maintain master lists to record and track all transactions.

The designs envisaged for this Contract are detailed in table below together with responsible agent assigned, who shall remain liable for all design requirements unless revised in writing by the Employer.

SERVICE / ACTIVITY	RESPONSIBLE AGENT
Design Review	Imbawula Civil Projects (Pty) Ltd (IMBAWULA)
Standard Specifications	City of Tshwane (CoT)
Specifications	IMBAWULA
Final Engineering Design	IMBAWULA
Tender Documentation & Drawings	IMBAWULA
Invite Tenders	CoT
Site Clarifications Meeting	CoT/IMBAWULA
Tender Evaluation	CoT

Appoint Contractor	CoT
Construction of Permanent Works	Contractor
Design and Construction of Temporary Works	Contractor
Full-time Site Supervision	IMBAWULA
Preparation of "As Built" drawings	IMBAWULA/Contractor

C3.2.5 Laboratories

A site laboratory is not required and all testing of asphalt, crushed stone, earthworks, pavement layers and concrete can be carried out by commercial laboratories or by the contractor himself for his process control. The Engineer will make use of a commercial laboratory for his acceptance control at the contractor's cost. The Contractor will be responsible for the cost of his process control testing. All process control test results shall be submitted to the Engineer.

C3.2.6 Accommodation of traffic

All proposals and plans for accommodation of traffic will have to be approved by the CoT and will be accompanied by relevant drawings.

C3.2.7 Contractor's camp site and office accommodation for supervisory staff

The main contractor will have to procure a site(s) for the establishment of his camp site and consulting engineer's supervisory staff. Payment for the contractor's camp site will be deemed to be priced under Section 001. Payment for the site and offices of the consulting engineer's supervisory staff will be deemed to be priced under Section 001 and Section 002 respectively.

C3.2.8 Temporary stockpile site(s)

The main contractor will have to procure a site(s) for the temporary stockpiling of road construction materials. A temporary stock piling site of ± 3500 m³ is required. Payment for the procurement of stock pile sites will be deemed to be priced under Section 201: pay item B201.03.

C3.2.9 Construction Method Statement

It is a requirement of this contract that the contractor shall submit, for approval by the engineer, detailed method statements for construction activities. Payment for the development, submission and approval of these construction method statements will be deemed to be priced under Section 001

C3.3 PROCUREMENT

C3.3.1 Preferential procurement procedures

C3.3.1.1 Requirements

C3.3.1.1.1 Employment of unskilled and semi-skilled labour in Labour Intensive Construction works

1. Requirements for the sourcing and engagement of labour

1.1 Unskilled and semi-skilled labour required for the execution of all labour-intensive works shall be engaged strictly in accordance with prevailing legislation and SANS 1914-5

1.2 , Participation of Targeted Labour.

1.3 The guideline pay rate will be as set by the CIDB/ SAFCEC Gazetted rates.

1.4 Tasks by the Contractor must be such that:

- (a) the average worker completes 5 tasks per week in 40 hours or less; and
- (b) the weakest worker completes 5 tasks per week in 55 hours or less.

1.5 The Contractor must revise the time taken to complete a task whenever it is established that the time taken to complete a weekly task is not within the requirements of 1.3.

1.6 The Contractor shall, through his CLO and labour desk, which has been set up through this contract, inform the local community of the labour-intensive works and the employment opportunities presented thereby. The local community shall include residents in the greater Tshwane Metropolitan area. Preference must be given to people with previous practical experience in construction and/or who come from households:

- (a) where the head of the household has less than a primary school education;
- (b) that have less than one full time person earning an income;
- (c) where subsistence agriculture is the source of income;
- (d) those who are not in receipt of any social security pension income.

1.7 The Contractor shall endeavour to ensure that the expenditure on the employment of temporary workers is in the following proportions:

- (a) 55% women;
- (b) 55% youth who are between the ages of 18 and 35; and
- (c) 2% persons with disabilities.

2. Specific provisions pertaining to SANS 1914-5

2.1 Definitions

Targeted labour: Unemployed persons who are employed as local labour on the project. The employment of all labour shall be via a labour desk and the CLO employed under this contract. No person without an ID document or valid work permit shall be employed.

2.2 Contract participation goals

2.2.1 There is no specified contract participation goal for the contract. The contract participation goal shall be measured in the performance of the contract to enable the employment provided to targeted labour to be quantified.

2.2.2 The wages and allowances used to calculate the contract participation goal shall, with respect to both time-related and task rated workers, comprise all wages paid and any training allowance paid in respect of agreed training programmes.

2.3 Terms and conditions for the engagement of targeted labour

Further to the provisions of Clause 3.3.2 of SANS 1914-5, written contracts shall be entered into with targeted labour. Variations to SANS 1914-5.

2.3.1 The definition for net amount shall be amended as follow:

Financial value of the contract upon completion, exclusive of any value added tax or sales tax which the law requires the employer to pay the contractor.

2.3.2 The schedule referred to in Clause 5.2 of SANS 1914-5 shall in addition reflect the status of targeted labour as women, youth and persons with disabilities and the number of formal training provided to targeted labour.

3. Training of labour

3.1 The Contractor shall engage an accredited trainer to provide training for all labour.

3.2 Training shall comprise training of 2 days for every two months that the labourer is employed.

3.3 Training shall comprise of related training which shall be approved by the engineer.

3.4 BE and/or SMME subcontractors shall be included in at least one applicable training course during their term of employment. It is proposed that a management course be provided to BE or SMME subcontractors.

3.5 Payment for training shall be made under Series 0, Section 001 and shall be as follows:

- (a) Payment for the training course(s).
- (b) Paid leave to enable labourers to attend course(s).
- (c) Payment for transport to attend training.

C3.3.1.1.2 Appointment of Community Liaison Officer

1. A community liaison officer (CLO) will be appointed in line with the "CODE OF GOOD PRACTISE TO APPOINT COMMUNITY LIAISON OFFICER" as approved by the mayoral committee on 02 May 2018.

2. community.

3. Provision for the payment of the CLO has been made in the Pricing Data.

4. The successful tenderer shall enter into an agreement with the Ward Councillor/Ward Committee whereby the Ward Councillor shall provide the Contractor with a Community Liaison Officer (CLO) for liaison with the recipient community.

5. The CLO shall set up regular meetings with the client and the contractor concerning the project. The contractor shall provide a report on all such meetings.
6. The CLO shall set up a labour desk from where employment of labour shall be conducted.
7. The agreement shall make provision for the payment by the Contractor to the CLO a maximum amount calculated as follows:
Wage per month = CoT's minimum T5-level monthly notch (prior to deductions). This amount is subject to annual increase in line with COT's salaries.
8. Only one CLO shall be appointed per project. If the project spans more than one Ward, the relevant Ward Councillors shall agree on one CLO to be appointed by the Contractor. Should no agreement be found as envisaged, the relevant Project Manager together with the Executive Director: Integrated Community Development, or their nominees, will interview prospective appointees and in their discretion appoint such CLO.
9. Notwithstanding the above, if the vastness of the project requires the use of more than one CLO, this will be permitted provided that the total monthly sum paid to all CLO's shall not exceed the amount allowed for asset out above.
10. Should the Contractor experience any difficulties with the community, these difficulties shall immediately be brought to the attention of the Department/Project Manager who shall arrange a meeting with the relevant Ward Councillor(s) and the CLO to resolve such difficulties.
11. The main Contractor shall ensure that any Subcontractor he may appoint shall adhere to these conditions but also subject to the provisos applicable to the duration of such subcontract.
12. Should any of the above conditions be less favourable than any Bargaining Council Agreement or Act applicable to the Contractor, the more favourable condition will apply.

C3.3.1.2 Resource standard pertaining to targeted procurement

The Contractor shall deliver the following deliverables in terms of the relevant SANS 1914 and the associated specification data:

C3.3.1.2.1 Provide business opportunities for targeted enterprises in terms of SANS 1914-4

1. General

Targeted enterprises shall be engaged in the performance of the contract in accordance with the requirements of SANS 1914-4 as amended in 2

2. Amendments to SANS 1914-4

2.1 Replace the existing definitions with the following:

Contract participation goal (CPG)

Value of supplies, services and works for which the contractor contracts targeted enterprises exclusive of any value added tax or sales tax which the law requires the employer to pay to the contractor, expressed as a percentage of the contract amount associated with the targeting strategy that is identified in the specification data

2.2 Add the following definitions:

Contract amount

1) Targeting strategy A

Financial value of the contract at the time of the award of the contract, exclusive of all allowances and any value added tax or sales tax which the law requires the employer to pay to the contractor

2) targeting strategy B

Financial value of the contract upon completion of all contractual obligations, exclusive of any value added tax or sales tax which the law requires the employer to pay to the contractor

Targeting strategy A

A strategy which:

- a) Links the granting of a preference by the employer in the evaluation of tender offers in return for the tendering of a contract participation goal or an undertaking to attain a specified contract participation goal at the time that tenders are evaluated; or
- b) Requires a contractor to achieve a minimum specified goal in the performance of a contract; or
- c) Involves both a) and b)

Targeting strategy B

A strategy which:

- a) links the payment of an incentive bonus to a contractor for the attainment of a specified contract participation goal; or
- b) requires the contractor to record and report on the quantum of work generated for targeted labour

2.3 Replace clauses 3.11 and 3.12 with the following:

3.1.1 The contractor shall engage targeted enterprises directly or indirectly in the performance of the contract to the extent that the total monetary value of such engagements exclusive of any value added tax or sales tax required by law, is sufficient to achieve the contract participation goal provided for in the specification data.

3.1.2 The contractor shall, in the case of targeting strategy A, submit details of his plan to achieve the contract participation goal to the employer's representative on the contract participation goal implementation plan form contained in annex C, within five working days of being instructed to do so. If no such instructions are given, these plans shall be submitted before the submission of the first claim for payment.

2.4 Replace 3.2.2 with the following:

3.2.2 Contractors shall submit completed targeted enterprise declaration affidavits and, where targeting strategy A applies, letters of undertaking to act as sub-consultants, subcontractors, suppliers, manufacturers or service providers (see annex D), in respect of each and every targeted enterprise and targeted partner whose contribution shall be counted towards the contract participation goal. These documents shall, unless otherwise stated in the specification data, be submitted to the employer's representative before the submission of the first claim for payment.

2.5 Replace 4.1 with the following:

4.1 The contractor shall enter into written contractual agreements with all the targeted, enterprises and targeted partners cited in the contract participation goal implementation plan and shall, as soon as is practicable, furnish the employer's representative with copies of such, agreements and the written acceptances thereof. The contract to be performed by the targeted enterprises and targeted partners shall, in the case of targeting strategy A, thereafter neither be reduced in scope, nor terminated without the prior written approval of the employer's representative, which shall not be unreasonably withheld or delayed.

2.6 Replace 4.2.1 with the following:

4.2.1 Where targeting strategy A applies and in the event that, through no fault of the contractor, a contracted targeted enterprise is found to be:

- a) Unable to perform, or to perform on time;
- b) Unable to produce acceptable work;
- c) Unwilling to perform work required; or
- d) Not fit to perform the service; the contractor shall notify the employer's representative of the apparent necessity to reduce or terminate such a targeted enterprise's contract, citing the reasons therefor.

2.7 Replace 4.3 with the following:

Where, in the case of targeting strategy A, an enterprise under contract was initially considered to be a targeted enterprise but is later discovered not to be so, or is found not to be creditable towards contract participation goals, the employer may consider a partial waiver of the contractor's obligations towards the achievement of the contract participation goal in respect of such a targeted enterprise, should the contractor satisfactorily demonstrate that he was justified in believing the enterprise to be a targeted enterprise and that eligibility standards were not violated.

2.8 Replace 6 with the following:

In the event that, and where targeting strategy A applies, the contractor fails to substantiate that any failure to achieve the contract participation goal was due to

- a) Quantitative underruns,
- b) The elimination of items contracted to targeted enterprises, or
- c) Any other reason beyond the contractor's control which may be acceptable to the employer, the sanctions provided for in the contract shall apply.

2.9 Delete "net amount" in definitions and replace "net amount" with "contract amount" wherever it appears in the text.

Clause	Specification Data	
The specification data associated with SANS 1914-5 is as follows		
2.7	The employers representative is:	Ms Manare Mohlaba
	Target area:	
	Target Area 1	The ward/wards in which the work package is to be performed
	Target Area 2	The ward/wards directly adjoining the ward/wards in which the work package is to be performed.
	Target Area 3	The region within which the ward/wards in which the work package is to be performed resides
	Target Area 4	The Tshwane Municipal area
2.17	Targeted enterprise is	Will be specified for each work package.
	The targeting strategy is	Strategy A b)
	The contract participation goal is	The min. goal is 10% and the maximum goal is 20% (The combined goal for the contract will not exceed 30%)
	The contract participation goal may only be achieved by subcontracting work to one or more targeted enterprises to perform commercially useful functions in the performance of the contract.	
2.9	The following weightings shall apply:	

	Target Area 1	1.2
	Target Area 2	1.0
	Target Area 3	0.8
	Target Area 4	0.6
6	Sanctions	<p>In the event that the Contractor fails to substantiate that any failure to achieve the Contract Participation Goal relating to the granting of preference was due to quantitative under runs, the elimination of items, or any other reason beyond the Contractor's control which may be acceptable to the Employer, it shall be liable to pay the Employer a financial penalty in the following manner:</p> $P = 0.15 \times \frac{(D - D_o)}{100} \times N_A$ <p>Where</p> <p><i>D</i> = required Contract Participation Goal percentage <i>D_o</i> = the Contract Participation Goal which the Employer's representative based on the credits passed, certifies as being achieved upon completion of the work package <i>N_A</i> = Net Amount <i>P</i> = Rand value of penalty payable</p>

C3.3.1.2.2 Employment of unskilled and semi-skilled labour in Labour Intensive Construction works in terms of SANS 1914-5

1. General

Targeted labour shall be engaged in the performance of the contract in accordance with the requirements of SANS 1914-5 as mended in 2

2. Amendments pertaining to SANS 1914-5

2.1 Replace the existing definitions with the following:

Contract participation goal (CPG)

Amount equal to the sum of the wages and allowances for which the contractor contracts to engage targeted labour exclusive of any value added tax or sales tax required by law, expressed as a percentage of the contract amount associated with the targeting strategy that is defined in the specification data

Targeted labour: Unemployed persons who are employed as local labour on a work package.

2.2 Add the following definitions:

Contract amount

1) targeting strategy A

Financial value of the contract at the time of the award of the contract, exclusive of all allowances and any value added tax or sales tax which the law requires the employer to pay to the contractor

2) targeting strategy B

Financial value of the contract upon completion of all contractual obligations, exclusive of any value added tax or sales tax which the law requires the employer to pay to the contractor

Targeting strategy A

A strategy which:

- a) Links the granting of a preference by the employer in the evaluation of tender offers in return for the tendering of a contract participation goal or an undertaking to attain a specified contract participation goal at the time that tenders are evaluated; or
- b) Requires a contractor to achieve a minimum specified goal in the performance of a contract; or
- c) Involves both a) and b)

Targeting strategy B

A strategy which:

- a) links the payment of an incentive bonus to a contractor for the attainment of a specified contract participation goal; or
- b) requires the contractor to record and report on the quantum of work generated for targeted labour

2.3 Terms and conditions for the engagement of targeted labour

Further to the provisions of Clause 3.3.2 of SANS 1914-5, written contracts shall be entered into with targeted labour.

2.4 The schedule referred to in Clause 5.2 of SANS 1914-5 shall in addition reflect the status of targeted labour as women, youth and persons with disabilities and the number of formal training provided to targeted labour.

2.5 Replace 6 with the following:

In the event that, and where targeting strategy A applies, the contractor fails to substantiate that any failure to achieve the contract participation goal was due to

- a) Quantitative underruns,
- b) The elimination of items contracted to targeted enterprises, or
- c) Any other reason beyond the contractor's control which may be acceptable to the employer, the sanctions provided for in the contract shall apply.

3. Training of targeted labour

- 3.1 The Contractor shall provide all the necessary on-the-job training to targeted labour to enable such labour to master the basic work techniques required to undertake the work in accordance with the requirements of the contract in a manner that does not compromise worker health and safety.
- 3.2 The cost of the formal training of targeted labour must be included on the total of the Prices.
- 3.3 The Contractor shall do nothing to dissuade targeted labour from participating in training programmes and shall take all reasonable steps to ensure that each beneficiary is provided with two days of formal training for every 22 days worked.
- 3.4 An allowance equal to 100 % of the task rate or daily rate shall be paid by the contractor to workers who attend formal training, in terms of 3.3 above.
- 3.5 Proof of compliance with the requirements of 3.2 to 3.4 must be provided by the Contractor to the Employer prior to submission of the final payment certificate.

Clause	Specification Data
The specification data associated with SANS 1914-1 is as follows	

Clause	Specification Data	
2.5	The employers representative is:	Manare Mohlaba
	Target area:	
	Target Area 1	The ward/wards in which the work package is to be performed
	Target Area 2	The ward/wards directly adjoining the ward/wards in which the work package is to be performed.
	Target Area 3	The region within which the ward/wards in which the work package is to be performed resides
	Target Area 4	The Tshwane Municipal area
2.2	The contract participation goal is	The min. goal is 10% and the maximum goal is 15% (The combined goal for the contract will not exceed 30%)
2.8	Targeted labour means	Unemployed persons who are employed as local labour on the work package
	The targeting strategy is	Strategy A b)
2.9	The following weightings shall apply:	
	Target Area 1	1.2
	Target Area 2	1.0
	Target Area 3	0.8
	Target Area 4	0.6
6	Sanctions	<p>In the event that the Contractor fails to substantiate that any failure to achieve the Contract Participation Goal relating to the granting of preference was due to quantitative under runs, the elimination of items, or any other reason beyond the Contractor's control which may be acceptable to the Employer, it shall be liable to pay the Employer a financial penalty in the following manner:</p> $P = 0.15 \times \frac{(D - D_o)}{100} \times N_A$ <p>Where</p> <p><i>D</i> = required Contract Participation Goal percentage <i>D_o</i> = the Contract Participation Goal which the Employer's representative based on the credits passed, certifies as being achieved upon completion of the work package <i>N_A</i> = Net Amount <i>P</i> = Rand value of penalty payable</p>

- C3.3.2.3.1 The contractor shall advertise and call for competitive tenders in accordance with the requirements stated in the specification data in respect of each portion of the works that are required to be subcontracted in terms of C3.3.2.1 in accordance with the relevant provisions of the latest edition of the CIDB Standard for Uniformity in Construction Procurement. The Contract Data in the associated procurement documents shall be based on the standard form of contract identified in the specification data, with minimal project specific variations and amendments that do not change their intended usage.
- C3.3.2.3.2 The contractor shall evaluate the tenders received in accordance with the provisions of the Standard Conditions of Tender contained in Annex F of Standard for Uniformity in Construction Procurement. The evaluation panel shall comprise equal representatives from the contractor and the steering committee for the ward/s on which the work package will impact.
- C3.3.2.3.3 The contractor shall without delay enter into a written contract with the successful tendering subcontractor based on their accepted tender submission.
- C3.3.2.3.4 The contractor shall remain responsible for providing the subcontracted portion of the works as if the work had not been subcontracted.

C3.3.2.4 Attendance on subcontractors

The Contractor shall in terms of the Clause 4.4.3 of the General Conditions of Contract for Construction Works (third edition 2015) be responsible for the subcontractors' acts, faults and defects as if they were his own. Specialist subcontractors, however, appointed by the employer, will operate independently but with close liaison and co-operation with the main contractor.

C3.3.2.5 Sanctions

In the event that the Contractor fails to substantiate that any failure to achieve the Target Value was due to quantitative under runs, the elimination of items, or any other reasons beyond the Contractor's control which may be acceptable to the Employer, it shall be liable to pay to the Employer a financial penalty calculated in the following manner:

$$\text{Where } \begin{cases} P & = & 0,50 \times (D - D_0) \\ D & = & \text{Target Value.} \\ D_0 & = & \text{the certified value of work allocated to BE subcontractors.} \end{cases}$$

C3.4 CONSTRUCTION

C3.4.1 Works specifications

C3.4.1.1 Applicable standards

- (a) Standard Specifications for Municipal Civil Engineering Works

The applicable Standard Specifications for Civil engineering Works shall be the document Standard Specifications for Municipal Civil Engineering Works, Third Edition 2005, issued by the Employer.

Tenderers, Contractors and Subcontractors shall obtain their own copies of the document **Standard Specifications for Municipal Civil Engineering Works, Third Edition 2005**, for tendering purposes and for use for the duration of the Contract from the Procurement Advice Centre, C de Wet Centre, 175 D F Malan Drive, Pretoria West and shall bear all expenses in this regard. Also freely available in electronic (pdf) format at:

<https://wayleave.tshwane.gov.za/page/details/3/?page=1>

The **Standard Specifications for Municipal Civil Engineering Works, Third Edition 2005** has been written to cover all types of municipal civil engineering works and it may therefore cover work not applicable to this contract.

The Particular Specifications together with the Drawings and Bill of Quantities clearly indicate the sections of the Standard Specifications which apply to this contract. Section C3.5.1.2.1 covers corrections and amendments to the Standard Specifications.

- (b) Specifications for Electrical Works

The specifications for all electrical works are included in Part C5: Appendices of this document.

C3.4.1.2 Applicable national and international standards

Will be specified per work package

C3.4.1.3 Particular/generic specifications

C3.4.1.3.1 Generic Labour-intensive Specification

This is contained in SANS 1921–5: Construction and management requirement for works contracts.

The contractor shall obtain a copy of this document which shall form the basis of all labour-intensive tasks on the project.

01 Scope

This specification establishes general requirements for activities which are to be executed by hand involving the following:

- a) Trenches having a depth of less than 1.5 metres
- b) Stormwater drainage
- c) Bus Stops

- d) Sidewalks and non-motorised transport infrastructure
- e) Water and sanitation

02 Precedence

Where this specification is in conflict with any other standard or specification referred to in the Scope of Works to this Contract, the requirements of this specification shall prevail.

03 Hand excavate-able material

Hand excavate-able material is material:

- a) granular materials:
 - i) whose consistency when profiled may in terms of table 1 be classified as very loose, loose, medium dens, or dense; or
 - ii) where the material is a gravel having a maximum particle size of 10mm and contains no cobbles or isolated boulders, no more than 15 blows of a Dynamic Cone Penetrometer (DCP) is required to penetrate 100mm;
- b) cohesive materials:
 - i) whose consistency when profiled may in terms of Table 1 be classified as very soft, soft, firm, stiff and stiff / very stiff; or
 - ii) where the material is a gravel having a maximum particle size of 10mm and contains no cobbles or isolated boulders, no more than 8 blows of a Dynamic Cone Penetrometer (DCP) is required to penetrate 100mm;

NOTE:

- 1) A boulder, a cobble and gravel is material with a particle size greater than 200mm, between 60 and 200mm.
- 2) A Dynamic Cone Penetrometer (DCP) is an instrument used to measure the in-situ shear resistance of a soil comprising a drop weight of approximately 10 kg which falls through a height of 400mm and drives a cone having a maximum diameter of 20mm (cone angle of 60° with respect to the horizontal) into the material being used.

Table 1: Consistency of materials when profiled

GRANULAR MATERIALS		COHESIVE MATERIALS	
CONSISTENCY	DESCRIPTION	CONSISTENCY	DESCRIPTION
Very loose	Crumbles very easily when scraped with a geological pick	Very soft	Geological pick head can easily be pushed in as far as the shaft of the handle
Loose	Small resistance to penetration by sharp end of a geological pick	Soft	Easily dented by thumb; sharp end of a geological pick can be pushed in 30-40mm; can be moulded by fingers with some pressure
Medium dense	Considerable resistance to penetration by sharp end of a geological pick	Firm	Indented by thumb with effort; sharp end of geological pick can be pushed in up to 10mm; very difficult to mould with fingers; can just be penetrated with an ordinary hand spade

GRANULAR MATERIALS		COHESIVE MATERIALS	
Dense	Very high resistance to penetration by the sharp end of geological pick; requires many blows for excavation	Stiff	Can be indented by thumb-nail; slight indentation produced by pushing geological pick point into soil; cannot be moulded by fingers
Very dense	High resistance to repeated blows of a geological pick	Very stiff	Indented by thumb-nail with difficulty; slight indentation produced by blow of a geological pick point

04 Trench excavation

All hand excavate-able material in trenches having a depth of less than 1.5 metres shall be excavated by hand.

05 Compaction of backfilling to trenches (areas not subject to traffic)

Backfilling to trenches shall be placed in layers of thickness (before compaction) not exceeding 100mm. Each layer shall be compacted using hand tampers.

- a) to 90% Proctor density;
- b) such that in excess of 5 blows of a Dynamic Cone Penetrometer (DCP) is required to penetrate 100mm of the backfill, provided that backfill does not comprise more than 10% gravel of size less than 10mm and contains no isolated boulders, or
- c) Such that the density of the compacted trench backfill is not less than that of the surrounding undisturbed soil when tested comparatively with a DCP.

06 Excavation

All hand excavate-able material including topsoil classified as hand excavate-able shall be excavated by hand. Harder material may be loosened by mechanical means prior to excavation by hand. Any material which presents the possibility of danger or injury to workers shall not be excavated by hand.

07 Clearing and grubbing

Grass and bushes shall be cleared by hand.

08 Shaping

All shaping shall be undertaken by hand.

09 Loading

All loading shall be done by hand. Haulage equipment should be selected in a manner that allows loading by hand to the greatest extent possible.

10 Haul

Excavation material shall be hauled to its point of placement by means of wheelbarrows where the haul distance is not greater than 150m.

11 Offloading

All material, however transported, is to be off-loaded by hand, unless tipper-trucks are utilized for haulage.

12 Spreading

All material shall be spread by hand.

13 Compaction

Small areas may be compacted by hand provided that the specified compaction is achieved. Appropriate rollers should be used where higher (than can be achieved by hand) levels of compaction are required or for large areas.

14 Grassing

All grassing shall be undertaken by sprigging, sodding, or seeding by hand.

15 Manufactured Elements

Elements manufactured or designed by the Contractor, such as manhole rings and cover slabs, pre-cast concrete planks and pipes, masonry unit and edge beams shall not individually, have a mass of more than 320kg. Where the mass of an element exceeds 55kg, consideration should be given to the size of the element relative to its total mass related to the number of workers who would be needed to lift such mass.

C3.4.1.3.2 Labour intensive competencies for supervisory and management staff

Established contractors shall only engage supervisory and management staff in labour intensive works that have completed the skills programme outlined in Table 1.

Emerging contractors shall have personally completed a LIC skills programme on the NQF level 2. All other site supervisory staff in the employ of emerging contractors must have completed a LIC skills programme on NQF level 2 or NQF level 4.

Table 1: Skills Programme for Supervisory and Management Staff

Personnel	NQF level	Unit standard titles	Skills programme description
Foreman/ supervisor	4	Implement labour intensive Construction Systems and Techniques	This unit standard must be completed, and any one of these 3 unit standards
		Use Labour Intensive Construction Methods to Construct and Maintain Roads and Stormwater Drainage	
		Use Labour Intensive Construction Methods to Construct and Maintain Water and Sanitation Services	
		Use Labour Intensive Construction Methods to Construct, Repair and Maintain Structures	
Site Agent/ Manager (i.e. the contractor's most senior representative that is resident on the site.	5	Manage Labour Intensive Construction Processes	Skills Programme against this single unit standard

Details of these skills programmes may be obtained from the CETA ETQA manager (e-mail: gerard@ceta.co.za, tel: 011-265-5900)

C3.4.1.3.3 Required performance characteristics on Traffic Markings

The following characteristics will be considered as indicative of the satisfactory performance of the traffic marking and should be read in conjunction with Section 613: Traffic Markings

01 Durability

Durability shall be indicated by the Traffic Wear Index determined in accordance with SABS 1248: 1995, Determination of traffic wear index.

02 Night-time visibility

Night-time retro-reflection shall be measured during normal working hours with a portable retro-reflectometer provided by the contractor in accordance with Method 1261: 1998. No separate payment shall be made for the retro-reflectometer as well as the tests.

Permanent traffic markings shall comply with the relevant levels of performance during the functional performance as indicated in Table 7.2, Vol 1, and Chapter 7 of the SADC RTSM with amendments on the Coefficient of Retro-reflection.

TABLE 7.2

FACTOR	NEW MATERIALS (Tested within one month of application)			USED MATERIALS (Tested after twelve months of application)		
	WHITE	YELLO W	RED	WHITE	YELLO W	RED
Colour X ⁽¹⁾	0,305	0,494	0,660	0,305	0,481	0,655
	0,335	0,470	0,610	0,350	0,444	0,579
	0,325	0,493	0,638	0,340	0,494	0,606
	0,295	0,522	0,690	0,295	0,054	0,690
Y ⁽¹⁾	0,315	0,505	0,340	0,315	0,518	0,345
	0,345	0,480	0,340	0,360	0,476	0,341
	0,355	0,457	0,312	0,370	0,426	0,314
	0,325	0,477	0,310	0,325	0,454	0,310
Luminance Factor	0,6	0,4	+0,08	0,45	0,3	+0,06
Coefficient of Retro reflection (millicandelas/lux/m²)	200	135	50	140	90	20
Skid Resistance BPN ⁽²⁾	50	50		50		

Note: All new surfaces shall be painted with 1.2mm thermoplastic paint

03 Materials

Plastic traffic marking material: Hot-melt plastic traffic marking material shall comply with the requirements of BS 3262. The binder shall be plasticized synthetic resin and the material shall be reflectorized by mixing at least 20% by mass Class A beads in accordance with BS 6088.

04 Colour

Colours to be used shall be bright white, yellow, red or black. The colour of the yellow paint should match colour Number D269 golden yellow of CKS 279 (colour B49 given in SABS 1091). The colour of red shall be as stated in Table 7.2 above.

05 Protection

After the paint has been applied, the traffic markings shall be protected against damage by traffic or other causes. The Contractor shall be responsible for the erection, placing and removal of warning boards, flags, cones and barricades as recommended in Vol2, Chapter 13 of the SADC RTSM. The Contractor shall be responsible for the placing of extra cones to prevent vehicles from crossing over wet paint. Should the wet paint be carried over the road surface or paint spillage takes place during the traffic marking operation such redundant paint shall be sandblasted. Black paint shall never be applied as a corrective measure to redundant traffic markings unless approved by the Engineer as a temporary measure. These traffic markings shall then be sandblasted as a final corrective measure.

06 Quality Control

The Contractor shall execute quality control of the traffic markings in accordance with a quality control plan approved by the employer. The quality control plan shall be based on a minimum level of assessment on at least 10 sets of 5 readings per 1km section of a road as indicated by the Engineer to determine the night-time visibility of each type of marking. The contractor shall provide the Engineer with the results of the Contractor's process quality control during the traffic marking process. The cost of such process quality control shall be borne by the Contractor.

Should it be clear that the traffic markings would not meet the required level of performance at any of the inspection dates; the Contractor may use his discretion to apply appropriate remedial actions to rectify the shortcomings after getting approval from the Engineer.

C3.4.2 Plant and materials

C3.4.2.1 Plant and materials supplied by the employer

The Employer will not supply any plant and/or materials. The contractor must source the equipment necessary for completion of the works to the specifications and within the construction period. The equipment available to the contractor must be listed on Form RD.C.5 of Section T2.2 of Volume 1 of the Tender Documents.

C3.4.2.2 Materials, samples and shop drawings

C3.4.2.2.1 Road Construction Materials

No borrow pits are provided. Where material cannot be obtained from cut on the works, the Contractor will be responsible to obtain the material required for the fill, sub-grade and pavement layers from commercial sources. No haul or over-haul will be paid on this material and haul and overhaul shall therefore be allowed for in the rates in the schedule of rates tendered by the Contractor.

Materials obtained from cuts on the works shall be temporary stockpiled at an approved temporary stockpile site. Contamination or damage to these materials will not be permitted and any such loss will be to the contractor's account.

C3.4.2.2.2 Aggregate for Concrete

The crushed stone and aggregate to be used in the base, surfacing and concrete must be approved by the Engineer before it may be used.

C3.4.2.2.3 Water for concrete and Construction Purposes

No natural water from rivers, streams, boreholes, pans, dams or irrigation canals shall be used for concrete, stabilised layers or compaction purposes. Only suitably purified (potable) water shall be used. The contractor must make adequate provision in his tender for all negotiations and procurement of water for construction activities and all related costs will be deemed to be included in his tendered rates.

C3.4.2.2.4 Spoil Material

The contractor shall make his own arrangements for the provision of a suitable place off the site for the disposal of material obtained from excavations, demolition, clearing and grubbing the demolition of boundary walls, brick work, foundation excavations, etc. The rates in the schedule of quantities shall include all costs or fees payable to cover the disposal of such material at an approved dumping site or

landfill site. The rates must allow for haul as no haul will be payable.

C3.4.2.2.5 Cement for concrete

The cement used for the construction of culverts, foundations and bridge structures as well as for stabilisation must be approved by the engineer prior to construction.

C3.4.3 Construction equipment

C3.4.3.1 Requirements for equipment

The construction methods adopted and plant and equipment used shall be at the discretion of the Contractor, provided always that the construction methods adopted and Plant used by the Contractor are appropriate in respect to the nature of the Works to be executed and the standards to be achieved in the Contract.

C3.4.3.2 Equipment provided by the Employer

The Employer will not provide any equipment.

C3.4.4 Existing services

C3.4.4.1 Location of known services

- (a) Drawings indicating the estimated position of existing services are provided in Volume 3 of the tender documents. Owing to the possible inaccuracy of records of existing services (water mains, electric cables, telephone cables, etc.) the Contractor shall locate any undetermined services that may be affected by this Contract prior to the commencement of excavations.

The Contractor shall complete all investigations into the presence and position of services well in advance of the start of construction work in any section and shall submit a report in good time to enable the Engineer to make whatever arrangements are necessary for the protection, removal or diversion of the services before any construction work commences. Payment for the exposure of services by excavation will be on the basis of the tendered rates item 001.03 or, if no appropriate rate exists, on a Dayworks basis.

- (b) Adequate written notice shall be given by the Contractor to the Engineer and to the service authority concerned, of the Contractor's intention to work across or near any existing services or structures and such work shall not commence until the necessary permission has been received. Work across or near any existing service or structure shall be carried out in compliance with the requirements of the relevant authority.

In the event of a service or structure being damaged, the Contractor shall immediately notify the authority concerned as well as the Engineer. The Contractor shall not repair any such service or structure unless instructed to do so. The Contractor shall be liable for the cost of making good damage caused by him. All such costs incurred by the service owner shall be deducted from monies due to the Contractor. No payment for accommodation of services will be made where no physical accommodation is provided or required, such as in temporary exposure of services during exploratory excavations.

- (c) The Contractor shall not damage adjoining fences and buildings when depositing spoil and/or materials. All claims arising from such causes shall be settled by the Contractor. The Contractor shall prevent damage to buildings, fences and other objects in the vicinity of the Works, as a result of the execution of this Contract.

The Contractor shall supply and erect shoring, screens, barricades, temporary supports and other items necessary for preventing such damage.

- (d) The Contractor shall make allowance for the presence of other service owners on the Site when they require access to carry out service relocation or maintenance work. Details regarding the relocation of services are dealt with under Series 0, Section 001, Clause 13 of the standard specifications. This Clause does not in any way relieve the Contractor of his obligations with regard to the protection of services under this Contract.

C3.4.4.2 Treatment of existing services

Before the contractor or subcontractor moves any services, they shall obtain the necessary wayleaves to proceed. The contractor shall also ascertain whether the CoT has any special procedures in this regard and shall adhere to these. The contractor shall also take the following into account:

- Accommodation of traffic and pedestrians.
- Access to private properties.
- Work procedure/methodology and approval by the engineer.
- Rerouting and/or moving of the service or other obstructions.

C3.4.4.3 Use of detection equipment for the location of underground services

To be used as and when instructed by the Engineer.

C3.4.4.4 Damage to services

The Engineer rules on the responsibility for services damaged. All services damaged by the Contractor shall be reported directly to relevant institution and will be rectified with immediate effect. No separate payment will be made to the Contractor for services damaged and repaired by him/her.

C3.4.4.5 Reinstatement of services and structures damaged during construction

The Engineer will determine the requirements and reinstatement procedures for the notification and repair of damage to services, penalties applicable to the damage of services.

C3.4.5 Site establishment

C3.4.5.1 Services and facilities provided by the employer

The employer will not provide any services and/or facilities.

C3.4.5.2 Facilities provided by the contractor

C3.4.5.2.1 Contractor's Camp site

No specific camp site has been earmarked for this contract and it will be up to the Contractor to make the necessary arrangements for a suitable camp site. The Contractor is however required to obtain approval of his choice of camp site from the Engineer. Once the Contractor has chosen a site, he will be required to make all necessary arrangements for water, telephone for both the engineer and site agent and power connections with the relevant service owners in the area.

He will have to obey all the relevant bylaws and statutory regulations that regulate the erection of a camp site. The above shall apply to each and every camp site the Contractor elects to erect.

The contractor shall provide a suitable site for his camp and for accommodating the work force. The choice of the site for the establishment of the camp, offices and the layout thereof, shall be approved by the engineer but shall not be permitted on the construction site. The camp site shall be cleared and grubbed and properly fenced with a security fence around the perimeter. The Contractor is to provide his own security at the camp or on the site if required, at his own expense.

After completion of the contract, the Contractor shall remove all his temporary buildings, plant and equipment. The site shall be made good and be left in a neat and tidy condition before a certificate of completion shall be issued.

C3.4.5.2.2 Water Supply

The Contractor shall make his own arrangement for potable and construction water. No natural water from rivers, streams, boreholes, pans, dams or irrigation canals shall be used for concrete or stabilised layers. Only drinking quality purified water shall be used. The Contractor must make adequate provision in his tender for all negotiations and procurement of water for construction activities and all related costs will be deemed to be included in his tendered rates.

C3.4.5.2.3 Power Supply

The Contractor shall liaise with the CoT on the disruption of power supply during the works and for the site camp, the contractor shall make his own arrangements.

C3.4.5.2.4 Ablution Facilities

The Contractor shall, at each construction area, provide sufficient portable chemical latrine units for males and females. The latrine units shall be serviced daily and kept in a hygienic and orderly state to the approval of the engineer. No separate payment shall be made for this requirement and the costs thereof shall be deemed to be included in the rates billed for the contractor's time-related obligations. The contractor shall allow for at least 1 unit per 10 labourers.

C3.4.5.2.5 Cellular Telephone

It is a requirement of the contract that the contractor shall equip his site agent(s) with a cellular telephone to allow for effective communication between the contractor's supervisory personnel and the engineer's supervisory staff. All costs associated with the provision of cellular telephones for the contractor's personnel shall be deemed to be included in rates billed for time-related charges.

C3.4.5.2.6 Site Facilities required by the Engineer

The offices as specified under Series 0, Section 002.03: Engineer's Accommodation and as billed in the schedule of quantities shall be provided for the Engineer and his staff and shall be to the satisfaction of the Engineer. The facilities shall include but not limited to;

- i. 12m x 2.4m Conference room
- ii. 1x 12-Seater boardroom table
- iii. 12 Office chairs (padded)
- iv. Male and Female ablutions for the engineer's staff and client's exclusive use
- v. 2 x 15 m² Office, for the Engineer and staff with
 - Air-conditioning complete with
 - Sufficient lighting and
 - Electric power sockets.
 - White boards and markers
 - Blinds
- vi. Three desks with three drawers (1 drawer must be lockable in each desk)
- vii. Drawing Rack
- viii. 6x Padded office chairs (3 of which is swivel chairs)
- ix. 2x steel filing cabinet
- x. Printer for A4 and A3 paper
- xi. Unlimited wireless internet
- xii. Cell Phone
- xiii. Kitchenette with fridge and microwave
- xiv. 6x carports for his exclusive use, a net shade cover will suffice.
- xv. Rain guage

The above items shall be read in conjunction with item 3.5.3.1 section 002.

C3.4.5.3 Storage and laboratory facilities

No storage or laboratory facilities are required by the Engineer.

C3.4.5.4 Other facilities and services

The contractor will have to find his own stockpile sites. These should be located as close to the project site as possible and shall be approved by the engineer. The contractor shall make his own arrangements for the provision of a suitable place off the site for the disposal of material. The contractor shall factor in all dump site fees into his spoil rate.

C3.4.5.5 Vehicles and equipment

The Engineer will not require the Contractor to provide vehicles and equipment for the Engineer's use.

C3.4.5.6 Advertising rights

Not applicable.

C3.4.5.7 Notice boards

Three notice boards will be supplied by the Contractor which will be erected at each apparent limit of construction (at Cnr of Nana Sita & Prince's Park and at Cnr. WF Nkomo & Prince's Park) and at the construction site camp as per instruction of the Engineer.

C3.4.6 Permits and wayleaves

The Engineer has arranged for way leaves from authorities for accommodation of traffic and other requirements after which the contractor will be responsible for maintaining and renewing of permits and wayleaves.

C3.4.7 Inspection of adjoining properties

Prior to work done on adjacent infrastructure and properties, the contractor shall give the property owners and Engineers a notice. The adjacent infrastructure and properties must be inspected, should the Engineer issue an instruction, the property or infrastructure recorded by means of a photo report before commencing with operations that have the potential to damage surrounding buildings and property.

C3.4.8 Water for construction purposes

No natural water from rivers, streams, boreholes, pans, dams or irrigation canals shall be used for concrete or stabilised layers.

Only drinking quality purified water shall be used. The Contractor must make adequate provision in his tender for all negotiations and procurement of water for construction activities and all related costs will be deemed to be included in his tendered rates.

C3.4.9 Survey control and setting out of the works

The Contractor shall be responsible for the true and proper setting out of the Works and for the correctness of the position, levels, dimensions and alignment of all parts of the Works and for the provision of all necessary instruments, appliances and labour in connection therewith. The contractor shall take care that property beacons, trigonometrical survey beacons or setting-out beacons are not displaced or destroyed without the consent of the engineer. Property beacons and trigonometrical survey beacons that have been displaced or destroyed shall be replaced by a registered land surveyor, who shall certify such replacement. The cost of replacing all beacons displaced or destroyed during the course of the contract without the consent of the engineer shall be the contractor's responsibility and included in the tender rates. The contractor shall check the accuracy and position of all beacons prior to commencing any works and shall be responsible thereafter for the accurate positioning and layout of the works.

C3.4.12 Training

Technical skills training shall be provided by the Contractor to all local labour involved in the Contract to enhance their development, and to assist in the empowerment of the local communities.

C3.5 MANAGEMENT

C3.5.1 Management of the works

C3.5.1.1 Applicable SANS 1921 standards

Will be specified per work package

C3.5.1.2.1 Corrections and amendments to the Standard Specifications

Amendments to the following Sections of the City of Tshwane Standard Specifications Municipal Civil Engineering Works

C3.5.2 Particular / generic specifications

None

C3.5.3 Variations and Additions to the Standard Specifications

The following particular specifications and variations and additions to the standard specifications are based on the Standard Specifications for Municipal Civil Engineering Works, Third Edition 2005 and are applicable to this contract. The following references from, and variations and additions to the Standard Specifications will be valid for this Contract.

The clauses and pay items in this portion of the Particular Specifications are numbered "B" followed by a number corresponding to the number of the relevant clause or pay item in the Standard Specifications. New clauses and pay items not covered by clauses or pay items in the Standard Specifications, if included here, are also designated "B" followed by a number. These numbers follow on the last clause or pay item number used in the relevant section of the Standard Specifications.

C3.5.3.1 All Other Civil Works (City of Tshwane - Standard Specification for Municipal Civil Engineering Works)

The following particular specifications and variations and additions to the standard specifications are based on the Standard Specifications for Municipal Civil Engineering Works, Third Edition 2005 and are applicable to the relocation/protection of services (excluding electrical services).

Amendments to the following Sections of the City of Tshwane Standard Specifications Municipal Civil Engineering Works.

CONTENTS

SERIES 0:	GENERAL
SECTION 001:	GENERAL REQUIREMENTS AND CHARGES
SECTION 002:	ENGINEER'S ACCOMMODATION
SERIES 1:	ANCILLARY WORKS
SECTION 101:	SITE CLEARING AND GRUBBING
SECTION 102:	ACCOMMODATION OF TRAFFIC
SECTION 103:	OVERHAUL
SECTION 106:	SERVICE DUCTS

SECTION B107: DAYWORKS

SERIES 2: EARTHWORKS

SECTION 201: GENERAL

SECTION 202: TRENCHING

SECTION 203: MASS EARTHWORKS

SERIES 5: DRAINAGE AND EROSION PROTECTION

SECTION 502: PREFABRICATED CULVERTS AND STORMWATER SEWERS

SECTION 503: KERBING AND CHANNELLING

SERIES 6: ROADS AND PARKING AREAS

SECTION 601: GRAVEL PAVEMENT LAYERS

SECTION 602: CRUSHED-STONE PAVEMENT LAYERS

SECTION 604: STABILIZATION

SECTION 605: PRIME COAT

SECTION 606: ASPHALT BASE AND SURFACING

SECTION 609: SEGMENTED PAVING

SECTION 612: TRAFFIC SIGNS

SECTION 613: TRAFFIC MARKING

SERIES 9: QUALITY CONTROL

SECTION 903: TESTING

SERIES 0: GENERAL

SECTION 001: GENERAL REQUIREMENTS AND CHARGES

B02 APPLICATION

Add the following paragraph to this clause:

“Reference is made to COLTO meaning the “Standard Specifications for Road and Bridge Works for State Road Authorities, 2020 Edition.” These references are found in several SERIES and SECTIONS. References will be to Tables and Clauses as numbered in COLTO. The contractor will be expected to obtain such a document which is available from SAICE, Private Bag X200, Halfway House, 1685. Tel. (011) 805 5947/8, e-mail civilinfo@service.org.za.

B17.02 OCCUPATIONAL HEALTH AND SAFETY ACT

Add the following to the second paragraph:

“Several amendments and revisions to the Regulation have subsequently been made. The Contractor shall take cognisance of these and implement these regulations where necessary.”

B17.07 PERSONNEL PROTECTIVE CLOTHING AND EQUIPMENT (PPE)

Add the following paragraph to this section:

“The contractor shall supply the engineer and his supervisory staff with the required PPE for use on the site.”

B31 MEASUREMENT AND PAYMENT

Amend sub-item 001.04.03 and renumber as follows:

Item		Unit
-------------	--	-------------

Amend sub-item 001.04.04 and renumber as follows:

B001.04.04	Provision of full-time safety officer	month
-------------------	--	--------------

Change the description as follows:

The month tendered shall include full compensation for the provision of a competent and experienced full time safety officer and assistants, who shall be on duty 24 hours per day for the duration of the construction work. The rate shall include for transport, equipment, communication devices, and all other incidental items required for him to carry out his duties as described.

Amend sub-item 001.04.06 and renumber as follows:

Item		Unit
-------------	--	-------------

B001.04.06 Provision of personnel protective clothing and equipment for the engineer's staff and visitors..... Lump sum

In the description of the pay item after “contractor’s employees, subcontractors ...” add “engineer and his staff.”

Add the following sub-items to 001.04.08 Other Obligations and number as follows:

“Item **Unit**

B001.04.08 Other Obligations

- (a) Environmental Obligations month
- (b) Health and Safety Obligations month

The monthly rate tendered shall include full compensation for the contractor’s obligations in respect of environmental obligations (appointment of Environmental Officer and implementation of EMPr) and health and safety obligations not covered elsewhere.”

Amend item 001.05 Community Officer and renumber as follows:

“Item **Unit**

B001.05 Community Liaison Officer

- B001.05.01 Wages and community related costs.....Prov sum
- B001.05.02 Contractor’s profit and handling cost in respect of item B001.05.01
percentage”

The provisional sum shall be expended as per the General Conditions of Contract.”

Add the following pay items:

“Item **Unit**

- B001.06.02 Penalties for Non-compliance to environmental issues
 - (a) Fixed penalty per occurrence.....number (No)
 - (b) Time related penalty for continual non-compliance with B001.06.02 above.....day
- B001.06.04 Penalties for Contractor Non-compliance with their general obligations:
 - (a) Fixed penalty per occurrence
 - (i) Minor.....number (No)
 - (ii) Medium.....number (No)
 - (iii) Severe.....number (No)
 - (b) Time related penalty for continual non-compliance with B001.06.04 above.....day

Item **Unit**

B001.07 Subcontractors for specialist activities

- B001.07.01 Relocation and protection of affected services excluding electrical services PC sum
- B001.07.02 Contractor's profit and handling cost in respect of item B001.07.01.....Percentage (%)
- B001.07.03 Landscaping PC sum
- B001.07.04 Contractor's profit and handling cost in respect of item B001.07.01.....Percentage (%)

The prime cost sum shall be expended as per the General Conditions of Contract.
 Refer to part C3 item C3.4.4.1 on the approach for existing services.

Item	Unit
B001.09	Interruption of services PC Sum

The PC Sum for interruption of services shall be for following the procedure included in Part 5: Appendices, for interrupting services. The PC Sum shall cover the cost of notifying affected parties, printing and distribution of pamphlets and posters, notifying the media, etc. The sum shall be expended as per the General Conditions of Contract.

Add the following new Sections:

“B32 EXTENSION OF TIME RESULTING FROM INCLEMENT WEATHER

The Contractor shall erect an effective rainfall gauge on the site of the works and record the daily rainfall figures in the site diary. The site diary shall be handed to the Employer's representative for his signature no later than 10 days after rain that is considered to justify an extension of time occurs. Records of rain days will be recorded in the minutes of the monthly site meeting.

Extension of time in terms of clause 5.12.2.2 of the general conditions of contract in respect of abnormal rainfall shall be determined in terms of the rainfall formula below. The extension of time that will be considered for a given calendar month shall not exceed the number of calendar days in that month less the average number of days in that month on which a rainfall of Y mm or more per day has been recorded, as derived from the existing rainfall records.

The formula below shall be used to calculate separately the delay for each calendar month or part thereof. It shall be calculated each month during the period referred to in the general conditions of contract as the time for completion of the works (including any extension thereof that may have been granted), or until the issue date of the certificate of practical completion, whichever is the shorter period. The delay calculated for a given month shall be used to determine the interim extension of time granted for that month. At the end of the applicable period referred to above, the aggregate of the monthly delays will be taken into account for the final determination of the total extension of time for the contract:

$$V = (Nw - Nn) + \frac{(Rw - Rn)}{X}$$

If any value of V is negative and its absolute value exceeds Nn, then V shall be taken as equal to minus Nn.

The delay for a part of a month shall be calculated by substituting pro rata values for the variables in the equation.

The symbols shall have the following meanings:

- V = Delay due to rain in calendar days in respect of the calendar month under consideration.
- Nw = Actual number of days in the relevant calendar month on which a rainfall of Y mm or more per day has been recorded.
- Rw = Actual rainfall in mm for the calendar month under consideration.
- Nn = Average number of days in the relevant calendar month (as derived from existing rainfall records provided below) on which a rainfall of Y mm or more per day has been recorded.
- Rn = Average rainfall in mm for the calendar month, as derived from the rainfall records provided below.
- X = 20
- Y = 10

The total delay that will be taken into account for the determination of the total extension of time for the contract shall be the algebraic sum of the monthly totals for the period under consideration. But if the grand total is negative,

the time for completion shall not be reduced on account of abnormal rainfall. The total extension of time for any calendar month shall not exceed $(Nc - Nn)$ calendar days, where Nc = number of calendar days in the month under consideration.

The factor $(Nw - Nn)$ shall be considered to represent a fair allowance for variations from the average number of days during which rainfall equals or exceeds Y mm per day.

The factor $(Rw - Rn) \div X$ shall be considered to represent a fair allowance for variations from the average for the number of days during which rainfall does not equal or exceed Y mm per day, but when wet conditions prevent or disrupt work.

This formula does not take into account any flood damage, which could cause further concurrent delays and which should be treated separately in so far as extension of time is concerned.

Accurate rain gauging shall be taken at a suitable point on the site daily at 08:00 unless otherwise agreed to by the engineer, and the contractor shall, at his own expense, take all the necessary precautions to ensure that the rain gauges cannot be interfered with by unauthorised persons.

Table B1215/1: Rainfall Data

Month	Jan	Feb	Mar	Apr	May	Jun	Jul	Aug	Sep	Oct	Nov	Dec	Total
'n' delays (rain)	6	4	5	5	2	2	0	0	2	4	10	5	45

* Reduced number of days if construction period spans the December/January holiday break.

N is the average number of days on which 10mm of rain or more has been measured by the weather station at Pretoria University Proefplaas.” “The Contractor shall allow in his programme for inclement weather. Should rain delays exceed over and above the 45 days, the Contractor will be eligible for extension of time.

B33 LEGAL PROVISIONS

Environmental compliance guidelines, contained in this volume are legal requirements which shall be adhered to. Failure or refusal on the part of the contractor to take the necessary steps to ensure the protection or preservation of the environment as contained in these documents or as required by statutory authorities or ordered by the employer, shall be sufficient cause for the employer to deduct penalties as follows:

- A fixed penalty of R20 000,00 shall be deducted for each and every occurrence of non-compliance with any of the requirements of Section C3.5.2.
- In addition a time-related penalty of R5 000,00 per day or part thereof over and above the fixed penalty shall be deducted for non-compliance to rectify any non-compliance to the environmental management plan within the allowable time after an instruction to this effect has been given.

This instruction shall state the allowable time, which shall be the time in hours for reinstatement of the defects. Should the contractor fail to adhere to this instruction, the time-related penalty shall be applied from the time the instruction was given.

The penalty shall be applied under Section 001 in the Bill of Quantities where it will be provided as a rate only item.

B34 SABS Cement Specifications

Where reference is made in this specification or the standard specifications to the cement specifications, e.g. SABS 471: Portland cement and rapid hardening Portland cement, it shall be replaced with the new specification:

SANS EN 197-1 "Cement compositions, specifications and conformity criteria Part 1: Common cements. On this contract CEM II/A-S 32,5 refer to section 3502, shall be used for chemical stabilization of pavement layers. Other cement compositions may be utilized after prior acceptance testing has been carried out.

B35 MIX DESIGNS

Before commencing with certain construction activities, the contractor shall, except where specified otherwise in the relevant construction sections in the Scope of Works, apply the following procedures with regards to mix designs:

- Taking and submitting samples of the relevant materials.
- Undertake the required mix design(s) or allow the engineer to undertake them.
- Produce, where required, laboratory, production/plant and/or trial mix (es).
- Undertake the required adjustments to the mix design(s) and reproduce required laboratory, production/plant and/or trial mix (es).
- Complete trial section(s) where required.
- Await the engineer's approval of the mix design(s) and trial section(s).

B36 METHOD STATEMENTS

The contractor shall provide the engineer with a method statement for each task he proposes to

undertake. The method statement shall contain, but not be limited to the sequence of operations, type of operations, final product and a time period for the completion of the works. The engineer shall sign off the method statement before the work/task is commenced.

A lump sum item is contained in Series 0, Section 001 to compensate the contractor for drafting and submitting method statements. A penalty is also included in Series 0, Section 001 for non-compliance of and exceeding the time period for completion of the work.

SECTION 002: ENGINEER'S ACCOMMODATION

B02 OFFICE AND LABORATORY ACCOMMODATION

B02.01 General

Add the following paragraphs

"The contractor may hire a mobile office container or office park home as an alternative to constructing huts and/or temporary structures provided all other requirements are met as outlined in section 02.01 of the CTMM"

"In addition, the offices shall be supplied with approved burglar proofing and the whole site shall be guarded by security full time during the day and night, as well as over weekends and holidays.

The site shall also be fenced with a 2,4m high security fence with a razor-cut wire being used as strands or with a brick wall. Flood lights, complete with poles and 500W globes shall be erected at each corner.

B02.02 General

Remove following paragraph

"(l) Telephone extensions shall be provided as specified and tendered rates shall include the of local calls and trunk calls in connection with the Works."

Replace with

"Smart phones shall be provided to the Engineer and staff which has sufficient processing storage and ram processor to efficiently open and analyse work documents remotely. The smart phones should include unlimited calls and internet connection. This shall be covered under bay item B002.03"

B02.03 Laboratories

Delete this clause, the Engineer's quality control testing will be carried out by an external commercial laboratory.

B04.02 Water, electricity, gas and telephone

Add the following to the end of the third paragraph:

"The power supply shall be regulated by a suitable voltage regulator in order to maintain a constant current and voltage level at all times to prevent damage to the office equipment and related machinery during power surges. In the event of damage to the office equipment and related machinery because of a faulty voltage regulator, the contractor shall be liable for payment of all repair or replacement costs of such damaged items.

The supply of electricity and water to the offices of the engineer's supervisory staff shall be maintained 24 hours per day, 7 days per week."

B002.03 Office and laboratory accommodation

B002.03.01 Provision of Engineer's Facilities including office accommodation, ablutions, all fittings, furniture, stationary, equipment and car ports.....PC Sum

This item must include items as outlined in the following sections;

In the, *Standard Specification for Municipal Civil Engineering works*;

- Series 0: subclause 02.01
- Series 0: subclause 02.02
- Series 0: subclause 02.04
- Series 0: subclause 02.07

In this document,

- Part C3: item C3.4.5.2.6

SERIES 1: ANCILLARY WORKS

SECTION 101: SITE CLEARING AND GRUBBING

B01 SCOPE

Add the following as a final paragraph:

“Clearing and grubbing for the construction of site offices shall not be measured separately and shall be deemed to be included in the rates tendered for item 001.01.01.”

B08 CONSERVATION OF TOPSOIL

Add to the end of the 1st paragraph:

“The depth of topsoil removed shall be reliant on the terrain, suitability of material and topsoil requirements of the work. Generally the contractor will not be required to remove topsoil to more than an average depth of 400mm unless approved by the engineer before commencing with topsoil removal from any particular area.”

Replace the second paragraph of this clause with the following:

“After clearing and grubbing, all topsoil shall be removed to either windrows alongside the construction area or to stockpile. Where ordered by the engineer, any topsoil that shall be required for the topsoiling of new banks and cuts, but which cannot be accommodated within the construction site, shall be loaded and hauled to the designated stockpile area where it shall be placed in temporary stockpiles for later use in the rehabilitation of the site affected by construction activities.”

SECTION 102: ACCOMMODATION OF TRAFFIC

B01 SCOPE

Add the following:

“It is a condition of this contract that traffic is accommodated taking into account the provisions of the latest edition of the South African Road Traffic Signs Manual (SARTSM). The latest version for use in the accommodation of traffic is volume 2, chapter 13 of the June 1999 edition. Copies of this publication are available from Government Printers –Tel: (012) 334 4507/8/9 or (012) 334 4510 Fax: (012) 323 9574.

B16 MEASUREMENT AND PAYMENT

Insert the following paragraph after the heading:

“The contractor’s tendered rates for the relevant items in the schedule of quantities shall include full compensation for all possible additional costs which may arise from the above and no claims for extra payment due to inconvenience as a result of the modus operandi will be considered.”

Add the following new section:

Item	Unit
B.102.01 Accommodation of Traffic and Maintenance of Bypasses	
(a) Along existing road.....	km
(b) Intersections – Signalised.....	No
(c) Intersections – Non Signalized.....	No
(d) Pedestrians traffic.....	No

Item	Unit
B102.14 Temporary traffic-control facilities	
<i>Amend pay item B102.14.05 as follows:</i>	
a) Road Signs, TW Series, 1200mm sides.....	No

Item	Unit
B.102/17 Barriers	
(a) Supply to site, initial placement, dismantling and re-erecting rented barriers during the works and removal from site of rented barriers.....	m

SECTION 106: SERVICE DUCTS

CONTENTS

01 SCOPE

This section covers the construction of service ducts to make provision for the easy installation, maintenance and protection of existing, new and

02 MATERIALS

Service ducts shall normally be constructed from one or more of the following materials:

- (a) Normal-duty PVC pipes conforming to SANS 791
- (b) Pitch-fibre pipes conforming to SANS 921 Class 1
- (c) Fibre-cement pressure pipes conforming to SANS 1223 Class C for COD pipes
- (d) Vitrified clay pipes conforming to SANS 559
- (e) Precast concrete pipes conforming to SANS 677 Type SI.

B12 MEASUREMENT AND PAYMENT

Add the following new section:

Item	Unit
B.106.07 MANHOLES	
(a) Supply and installation of prefabricated fibre cement manhole.....	No
(b) Testing of Ducts (Mendrill Test).....	L/Sum

“SECTION B107: DAYWORKS

CONTENTS

- B01 SCOPE
- B02 ORDERING OF DAYWORK
- B03 MEASUREMENT AND PAYMENT

B01 SCOPE

This section covers the listing of daywork items in accordance with sub-clause 6.5 of the General Conditions of Contract (2015), for the use in determining payment for work which cannot be quantified in specific units in the Pricing Schedule, or work ordered by the engineer during the construction period which was not foreseen at tender stage and for which no applicable rate exists in the Pricing Schedule.

B02 ORDERING OF DAYWORK

No daywork shall be undertaken unless written authorisation has been obtained from the engineer.

B107 MEASUREMENT AND PAYMENT

Item	Unit
B107.01 Personnel	
(a) Unskilled labour	hour (h)
(b) Semi-skilled labour	hour (h)
(c) Skilled labour	hour (h)
(d) Ganger	hour (h)
(e) Foreman	hour (h)

Item	Unit
B107.02 Extra-over item B003.01 for charges and overheads	
(a) Specify.....	Percentage (%)

Item	Unit
B107.02 Equipment	
(a) Tipper Trucks	hour (h)
(b) Generator (15Kva).....	hour (h)
(c) Grader (Mass 16 – 20 tons).....	hour (h)
(d) Pneumatic Roller (14 – 21 ton)	hour (h)
(e) Pedestrian Roller	hour (h)
(f) Pumps.....	hour (h)

Item	Unit
B107.04 Transport for construction equipment	
(a) LDV	kilometre (km)
(b) Flatbed truck	kilometre (km)

The unit of measurement for items B003.01 and B003.02 shall be the hour for the utilisation of the item of equipment or personnel. Non-working hours for transport breakdown, lack of operator of any other reason shall not be measured. The time shall be taken from the time that the personnel and/or equipment depart until return.

Measurement shall only be for work instructed and directed by the engineer, where the engineer considers no other appropriate rate is applicable in the Pricing Schedule. Prior to the commencement of any work by the personnel described under item B003.01 the contractor must obtain written consent from the engineer regarding their classification in terms of "unskilled", semi-skilled" and "skilled" personnel.

The tendered rates for labour under B003.01 shall include full compensation to cover overhead charges and profit, leave pay, bonuses, subsistence, allowances, Employer's contributions, additional payment for overtime where applicable, insurances, housing, site supervision, use of small hand tools and appliances, non -mechanical plant and equipment and consumable stores, for all administrative, supervisory, operative and contingent costs, relating to the supply of personnel.

The tendered rates for plant for item B003.02 shall be an all-inclusive hire charge for the use of the vehicle and driver or plant/equipment and operator and shall apply only to vehicles plant and equipment nominated in writing by the engineer, for all administrative, supervisory, operative and contingent cost, and profit relating to the running of the plant.

The unit of measurement for subitem B003.03(a) shall be the amounts actually paid for the procurement of materials to be purchased and shall be made in accordance with the provision of the General Conditions of Contract (2010). Only the actual quantities of materials used, as verified by the engineer, shall be paid for.

The percentage tendered for subitem B003.03(b) shall be the percentage of the amounts actually paid for the procurement of materials as ordered under subitem B003.03(a) and shall be in full and final compensation in respect of the contractor's handling costs, profit and all other charges in connection with the procurement and supply of the materials to the point of usage.

The unit of measurement for item B003.04 shall be the kilometre distance that the vehicle travelled for transporting personnel and/or plant. All travelling shall be approved by the engineer.

The tendered rate for item B003.04 shall include full compensation for the cost of the vehicle including fuel, maintenance depreciation and running costs. The above-mentioned tendered rates shall be full compensation for the various items as specified and no further profit shall be paid.

SERIES 2: EARTHWORKS

SECTION 201: GENERAL

B07 STOCKPILING OF MATERIALS

Replace the content of this clause with the following”

“The contractor shall locate his own stockpile and spoil sites. These sites shall not be excessively far from the construction site and be easily accessible. The site shall be approved by the engineer prior to it being utilized. Payment for the location of the stockpile sites shall not be paid for separately, neither shall payment be made for any haul.

Replace the third paragraph with:

“Before any stockpiling may be done the area shall be cleared of topsoil to a sufficient depth that will subsequently allow for the complete rehabilitation of the site with a cover of topsoil that does not exceed 100mm cover and is not less than 75mm in depth. If there is insufficient topsoil; the contractor shall acquire whatever balance is needed to rehabilitate the area at his own cost. No make-up topsoil shall be taken from the road reserve. The topsoil shall be stored in an area that shall not be affected by construction activities nor impede the natural flow of water. The topsoil so windrowed or stockpiled and its surrounds shall be kept free of all undesirable vegetation. The contractor shall not commence his stockpiling activities without prior written approval from the engineer that the site has been adequately prepared.

Stockpile sites shall be graded smooth with an adequate slope to ensure proper drainage. The surface shall be watered and compacted to a depth of at least 150 mm and to a density of 90% of modified AASHTO density. The compacted surface shall be firm. Upon completion, the surface shall be swept clean. Stockpile sites shall be large enough to allow the different types of material to be stockpiled without overlapping or exceeding the limits of the prepared site.

Enlargement of the stockpile sites after the stockpiles have been placed will not be permitted without the engineer's approval. After the stockpiled material has been removed, the site shall be reinstated as closely as possible to its original condition by ripping of the affected areas, re-landscaping if necessary, re- instatement of the topsoil and re-vegetation.”

09 MEASUREMENT AND PAYMENT

Item

B201.02 Temporary stockpiling of material

Delete in the second paragraph “... within the free haul distance ...”

Add to the second paragraph:

“No haul shall be measured and paid.”

Delete the last paragraph.

SECTION 202: TRENCHING

02 GENERAL

Add the following to paragraph 2:

“The width of clearing and grubbing for trenches shall be three times the authorized width of the trench or the width listed under pay item 101.01.”

Add the following to the last paragraph:

“All trenching for this project will be regarded as trenching in built-up areas”

03 CLASSIFICATION OF MATERIALS EXCAVATED

Amend the classification as follows:

a. Hard Material

Material that cannot be efficiently removed without blasting or without wedging and splitting with pneumatic tools as well as boulders exceeding 0,15m³.

b. Soft Material

Material that is not classified as hard materials will all be regarded as soft excavation.

c. Intermediate Material

No intermediate material classification will be applicable to trenching.

04 EXCAVATION

04.02 Hand excavations

Add the following:

“The payment for hand excavation authorized by the Engineer excludes the hand excavation listed under pay item 202.03.”

09 PREPARATION OF TRENCH BOTTOMS

Add the following to the fourth paragraph:

“The additional cost for the 150mm selected gravel bedding in hard material over and above the cost for the 100mm bedding for class ‘B’ bedding shall not be paid for separately but shall be included in the rates for hard excavation.”

11 DEALING WITH WATER

Add the following to the second paragraph:

"Where instructed by the Engineer, the subsurface drain shall be constructed only with 19mm crushed stone or a perforated PVC pipe surrounded by crushed stone. Pipe diameter as per the Engineer's instruction."

12 SOILCRETE

Add the following requirement:

"The material quality of the gravel – soil used for soilcrete shall comply to G6 – material according to TRH 14 or better underneath road surfaces or G7 elsewhere. The requirement of a maximum plasticity index not exceeding 10 however remains."

13 BACKFILLING

Delete the following in the first paragraph:

"200mm in the case of water pipes"

14 TRENCHES WITHIN ROAD RESERVES

Add the following requirement to the eleventh paragraph:

"The selected material for the top three 150mm stabilized layers shall be at least material of G5 – TRH 14 quality."

Add the following paragraph:

"The contractor shall install and maintain approved 1,0m minimum high orange plastic safety net barriers alongside both sides of open trenches. Where 1m high existing fences or walls protect the open trenches the safety net barriers may be omitted at that side. Include the cost for this in the rates for trench excavation."

16 MEASUREMENT AND PAYMENT

Amend the following pay items and renumber as follows:

Item	Unit
B202.02	Extra over items 202.01, 202.03, 202.04 and 202.09 for excavating in

Omit intermediate material.

the depth, if necessary by hand, outside the normal trench profile for manholes, catch pits, valve chambers, thrust blocks, house connections, etc, as well as for removing unsuitable material from trench floors as specified in sub-clause 04.03 of this section."

Item	Unit
B202.03	Excavations and backfill outside the normal trench profile cubic metre (m³)

Amend the first paragraph as follows:

“The unit of measurement shall be the cubic metre of material excavated in soft material irrespective of the depth, if necessary by hand, outside the normal trench profile for manholes, catch pits, valve chambers, thrust blocks, house connections, etc, as well as for removing unsuitable material from trench floors as specified in sub-clause 04.03 of this section.”

Item	Unit
B202.07.02 From commercial sources.....	cubic metre (m³)

Add the following pay item:

Item	Unit
B202.09 Subsurface drains in trench bottoms (Drawing number indicated or description listed)	metre (m)

Item	Unit
B202.16 Extra over item 202.01 for backfilling using stabilized material.....	cubic metre (m³)

The unit of measure shall be the cubic metre (m³) of backfill material stabilized. The tendered rate shall include full compensation for the additional cost to stabilize the backfill material with 5% cement.”

SECTION 203: MASS EARTHWORKS

B03.02 Fill

Replace in subclause (a), the “750 mm” dimension with “100 mm”.

Add the following under subclause (b):

“The maximum swell at 100% Mod AASHTO compaction shall not be more than 2%.”

B14 MEASUREMENT AND PAYMENT

Add the following to items 203.14 and 203.15:

“Overhaul shall not be paid and all haul costs shall be included in the extra over rate of the item.”:

Add the following pay item:

Item	Unit
B203.16 Milling of asphalt	
B203.16.01 Providing the milling machineNumber (No)
B203.16.02 Milling, Contractor takes ownership of asphalt	
B203.16.02.01 Thickness up to 100mm.....square metre (m ²) Etc in 100mm increments	
For subitem B203.16.01 the unit of measurement shall be the number of establishments of the milling machine upon prior approval by the Engineer. The tendered rate shall include full compensation for establishment and de-establishment of the milling machine on the site. Payment shall not be made for moving the milling machine around on the site.	
For subitem B203.16.02.01 the unit of measurement shall be the area of milled asphalt. A distinction shall be made between various thicknesses of milled asphalt. The tendered rates shall include full compensation for demarcating the excavation, for milling the material, and for loading and hauling to a site identified by the Contractor.	

SERIES 5: DRAINAGE AND EROSION PROTECTION

SECTION 502: PREFABRICATED CULVERTS AND STORMWATER

SEWERS B03 MATERIALS

B03.06 Skewed ends

Delete the first and second paragraphs and substitute the following:

“Where pipe culverts are to be constructed at a skew angle, the pipe units shall be cut neatly and flush with the front face of the headwall. Precast portal and rectangular culverts placed on a skew shall be supplied with cast in situ skewed ends as shown on the drawings. In situ skew ends are to be constructed simultaneously with the wingwalls and headwalls.”

B12 MEASUREMENT AND PAYMENT

Add the following new payment items:

Item	Unit
B502.24 Cutting of concrete pipes (size specified)	number (No)

The unit of measurement shall be the number of pipes that have been cut. The tendered rate shall be full compensation for the cutting, by means of mechanical saw (angle grinder) and finishing off of the pipes for the specific angle of skew at which the pipes must be laid.

Item	Unit
B502.25 Demolishing and/or removing of structures that cannot be removed by bulldozer, including dumping site fees and an unlimited free-haul distance	
(a) Reinforced concrete structures	cubic metre (m ³)
(b) Plain concrete, side drain structures, kerbs, brickwork, manholes, cleaning eyes.....	cubic metre (m ³)
(c) Prefabricated concrete culverts (size indicated)	metre (m)

The unit of measurement for item B502.25(a) and (b) shall be the cubic metre of existing concrete removed. The unit of measure for item B502.25(c) shall be the metre of culvert pipes removed in their entirety together with all concrete and other material.

The tendered rate shall include full compensation for all demolition and for loading, transporting and disposing of the products of demolition to a Municipal dumping site, including an unlimited free haul distance. Payment shall distinguish between plain and reinforced concrete. For the purposes of this item, reinforced concrete shall be defined as concrete containing at least 0,2% of steel reinforcement measured by volume. Payment for any excavation and backfilling required for removing the existing prefabricated culverts shall be made separately under items in Section 202.

Item	Unit
B502.26 Repairing or replacing existing drainage systems.....	provisional sum

The provisional sum given for repairing or replacing existing drainage systems shall be expended in terms of the general conditions of contract.”

SERIES 5 : DRAINAGE AND EROSION PROTECTION

SECTION 503 : KERBING AND CHANNELING

02 MATERIALS

02.01 Concrete

All concrete work shall be carried out in accordance with the requirements of sections 702 and 704 of these Specifications.

02.02 Kerbing and channelling

Precast kerbing shall be of the dimensions shown on the Drawings, shall comply with the requirements of SANS 927 and shall, unless otherwise directed, be supplied in 1,0 m long sections, except around curves at road intersections where they shall be 0,3 m in length. Kerbing and channelling cast in situ shall be of the class of concrete indicated on the Drawings.

02.03 Bedding material

The material on which precast concrete kerbs are to be bedded shall consist of crushed stone, cinders, slag, sand or other approved porous material with a maximum particle size of 13,2 mm.

B08 MEASUREMENT AND PAYMENT

Item	Unit
Cutting bituminous surfacing and pavement layers for concrete kerbing, channelling or concrete lined drains.....	m³

SERIES 6: ROADS AND PARKING AREAS

SECTION 601: GRAVEL PAVEMENT LAYERS

B03 MATERIALS

B03.01 General

Add the following at the end of the fourth paragraph:

"For chemically stabilised layers the material shall conform to the requirements in Table B03/1. below".

"TABLE B03/1: REQUIREMENTS FOR CHEMICALLY STABILISED LAYERS

Classification	C1	C2	C3	C4
----------------	----	----	----	----

Material before treatment	At least G2 quality	At least G4 quality	At least G5 quality	At least G6 quality
PI after treatment	Non-plastic	Non-plastic	6 max. *(1)	6 max. *(1)
UCS (MPa) *(2)	6 min.	4 min.	1,5 min	0,75 min.
ITS (kPa) *(3)	-	-	250 min.	200 min.
WDD (% loss)	5 max.	10 max.	20 max.	30 max.

Note:

- * (1) For materials derived from the basic crystalline rock group, the Plasticity Index after stabilisation shall be non-plastic.
- * (2) Unconfined Compressive Strength @ 100% Mod. AASHTO density
- * (3) Indirect tensile Strength @ 100% Mod. AASHTO density
- * (4) Wet/Dry Durability according to the method given in Section 903, clause B14.03.

B03.02 Compaction requirements

Amend the compaction requirements as follows in terms of modified AASHTO density:

Road Pavement

Selected layer	95%
Subbase	97%

Sidewalks

Subbase	97%
---------	-----

BRT Lane Pavement

Selected layer	95%
Subbase	97%

Replace the contents of the last paragraph with the following:

“The materials to be used in the various layers and its/their compaction are specified on the pavement drawings.”

B07 MEASUREMENT AND PAYMENT

Amend pay item 601.02 as follows:

Prefix the item and all sub items with “B”.

Revise the description to read:

“Gravel layers constructed from material obtained from commercial or the contractor’s own sources”.

Replace the last paragraph with the following:

The tendered rates shall include full compensation for procuring, furnishing and placing all materials including testing and no overhaul shall be paid.”

SECTION 602 CRUSHED-STONE PAVEMENT LAYERS

B02 MATERIALS

B02.01 General

Delete in the first paragraph “.... in TRH 14 and”.

B02.02 Soluble salts

Replace the test methods in subclause (b) with the following:

“Electrical conductivity and pH – TMH 1 A21T, SANS 6240 (on the <7,1 mm fraction).

Acid-soluble sulfate content – BS 1377:1990, SANS 5850-2.

Water soluble sulfate content – SANS 5850-1.”

B02.03 Grading requirements

Replace the first three paragraphs with the following:

“The G1 crushed stone material for the construction of the base layer shall comply with the requirements of the COTO Standard Specifications for Road and Bridge Works for South African Road Authorities October 2020, Chapter 4 Section 4.1 Part A Clause A4.1.5.8.

Tests to determine whether the crushed stone material complies with the specified grading requirements shall be conducted after the material has been compacted. The results shall be correlated and adjusted with the after slushing grading.”

Delete Table 602/1.

B02.04 Compaction requirements

Add the following to the first paragraph:

“The field density shall be tested with a nuclear density apparatus. Holes shall be drilled in the crushed stone material to carry out the tests.”

SECTION 604: STABILIZATION

B01 SCOPE

Add the following paragraph:

“The chemical stabilisation design process shall be carried out according to the requirements in the COTO Standard Specifications for Road and Bridge Works for South African Authorities October 2020, Chapter 4 Section 4.4 Clause A4.4.7.1(c).”

SECTION 605: PRIME COAT

B02 MATERIALS

B02.01 Prime material

Replace the content of the clause with the following:

“The prime material shall be one of the following:

- MC-30 cut-back bitumen to SANS 4001-BT2.
- MC-10 cut-back bitumen to SANS 4001-BT2.
- Invert bitumen emulsion (MSP1) to SANS 4001-BT5.
- Enviro emulsion prime.

The type of prime and application rate best suited for the granular base shall be determined after construction of the base. The contractor shall provide about 20 litres of each prime and apply it at different application rates with a brush on the base. The Engineer shall evaluate the performance of the primes in accordance with the latest edition of TRH1/Sabita Manual 26 and then instruct the type of prime and application rate to be applied. No payment shall be made for the tests to determine the appropriate priming product.”

B03 EQUIPMENT

Add the following paragraph at the end of the clause:

“When the area is too small to apply the prime with a binder distributor, the Engineer can approve the application by hand.”

SECTION 606: ASPHALT BASE AND SURFACING

B01 SCOPE

Add the following:

“This section also covers the application of a resin modified cement grouted open graded asphalt (RMCG asphalt).RMCG is a semi-rigid asphalt surfacing comprising a specifically graded conventional open graded asphalt (20% - 25% voids, target = 22%), the voids of which are filled with a resin modified cementitious grout such as Salphalt or similar approved.”

B02 MATERIALS

B02.01 Bituminous binders

Replace the contents of this clause with the following:

“Penetration grade bitumen shall comply with the requirements of SANS 4001-BT1. Modified bitumen shall comply with the latest edition of TG1.”

B03 COMPOSITION OF ASPHALT BASE AND SURFACING

Replace the second paragraph with the following:

"The Contractor shall be responsible for the design of the asphalt mixes. The Engineer will only confirm the use of a mix upon receipt of the Contractor's design mix."

Replace the penultimate paragraph with the following:

"The designs of the mixes shall be in accordance with the latest relevant applicable SABITA manuals. Except for the EME base layer, reclaimed asphalt to a maximum of 15% will be permitted in the mixes. All surfacing mixes shall contain 1% lime, and not less than 0,5% lime when a nano-product wetting agent is used."

Add the following:

"RMCG asphalt shall comply with the following requirements:

The grading limits for the combined aggregate shall comply with the requirements in table 606/2 for coarse open-graded surfacing.

Grout for the RMCG asphalt shall conform to the manufacturer's specifications.

Subject to the approval of the Engineer, the properties of the RMCG asphalt shall conform to the manufacturer's specifications but shall at least be equivalent to the following values on specimens manufactured from 100mm briquettes in an approved laboratory:

- (a) Binder Content 4%
- (b) Voids 20% - 25% (Target 22%)
- (c) Marshall properties at 60°C after 28 days:
 - Stability >10kN
 - Flow 3-6mm
 - Stability / flow ratio > 2,5kN/mm
- (d) A resilient modulus after 28 days of not less than 4 000MPa
- (e) An indirect tensile strength at 25°C at a loading frequency of 1,0Hz of not less than 600MPa.

The lower EME asphalt base layer shall have a slightly higher binder content for improved fatigue properties, and the upper layer slightly less binder for improved rut resistance."

B11 COMPACTION

Add the following paragraph:

"RMCG asphalt be constructed in two stages as follows:

- (a) The open graded asphalt shall be paver laid and compacted with a tandem steel wheel roller only.
- (b) After the asphalt has cooled to below 30°C, the resin modified cementitious grout shall be poured onto the asphalt and vibrated into the voids using light smooth steel wheeled vibratory rollers. No grouting shall be carried out when the surface temperature rises above 40°C.

No traffic shall be permitted onto the layer before the grout is applied or until a period agreed to by the manufacturer after the grout is applied.”

SECTION 609: SEGMENTED

PAVING B03 MATERIALS

B03.01 Precast concrete segmental blocks

Replace in the first paragraph “... as specified in the Project Specifications, ...” with “... as specified on the Drawings,”.

B04 CONSTRUCTION

B04.01 Construction of paving with segmental blocks

(d) Placing of bedding sand

In the last paragraph, replace the first sentence with:

“The uncompacted thickness of the sand shall be such that, after compaction, the sand layer shall be 20 mm plus 15 mm or minus 5 mm thick.”

(g) Joint filling

Add the following new paragraph:

“The Contractor shall for the first 2 months after the paving blocks have been subjected to traffic, maintain the complete joint filling at all times and no cost to the Employer. Any resanding required thereafter and instructed by the Engineer will be paid for.”

B06 TOLERANCES

Replace the tolerance in the subclauses as follows:

B06.01 Line of pattern

- (a) 3 mm maximum.
- (b) 10 mm maximum.

B06.02 Vertical deviation from a 3 m straight edge

- (a) Plus 3 minus 0 mm.
- (b) Plus 3 minus 5 mm.

B06.03 Surface levels of adjacent units

Flush but 2 mm in isolated locations.”

B09 MEASUREMENT AND PAYMENT

Add the following pay items:

Item	Unit
B609.07 Resanding of the segmental block pavement on instruction of the Engineer	square metre (m2)

The unit of measurement shall be the area in square metre of the paving that is resanded.

The tendered rate shall include full compensation for procuring the jointing sand, for placing it on the paving and brooming the sand into the joints, and for cleaning the block paving at completion.”

B609.08 Provision and application of:

B609.08.01 Ant poisonPC Sum
B609.08.02 Add the Contractor's chargesPercentage (%)
B609.08.03 Vegetation destroyerPC Sum
B609.08.04 Ant poisonPercentage (%)

Pay item will be as outline on Item 505.11 in the Standard specifications for municipal civil engineering works

SECTION 613: TRAFFIC MARKINGS

B02 MATERIALS

B02.01 Paint

Add the following:

- (a) StreetBond 150 Asphalt pavement coating

Included in this section is the supply and application of the StreetBond 150 asphalt pavement coating as supplied by Asphalt Impressions or similarly approved. The materials used and the installation thereof are to comply with the StreetBond 150 Specifications attached as APPENDIX A – Specialist materials specifications (StreetBond 150).

- (b) Horizont Klemmfix Guide Curb Separator System

Included in this section is the supply and installation of the Horizont Klemmfix Guide Curb Separator System as supplied by Blue Key Road Safety Technology CC or similarly approved. The materials used and the installation thereof are to comply with the Horizont Klemmfix Specifications attached as APPENDIX A – Specialist materials specifications (Horizont Klemmfix Guide Curb Separator System)

B14 MEASUREMENT AND PAYMENT

Add the following pay items:

Item	Unit
B613.01.07 Road marking paint (water based):	
B613.01.07.01 Red lines (broken or unbroken) TRT 1000mm wide.....	kilometre (km)

The unit of measurement shall be the kilometre of painted line. The tendered rate shall include full compensation for procuring and furnishing all materials, painting, protecting and maintenance as specified.

Item	Unit
-------------	-------------

B613.07 Re-establishing the painting unit at the end of the maintenance period..... Sum

The tendered sum shall include full compensation for the re-establishment on the site and for the later removing all special equipment, personnel, etc, as may be required for repainting the road-traffic markings at the end of the maintenance period. The contractor will be paid at tender rates for repainting the road markings.

Item **Unit**

B613.09 Epoxy modified, acrylic, waterborne coating for HMA pavements (Streetbond 150 or similar)

B613.09.01 100mm wide line as shown on road marking drawings metre (m)

The unit of measurement shall be the linear metre of painted line. The tendered rate shall include full compensation for procuring and furnishing all materials, painting, protecting and maintenance as specified.

SERIES 9: QUALITY CONTROL

C3.5.1.4 Planning and Programming

The Contractor shall submit within fourteen (14) days a suitable and realistic construction programme for the consideration of the Engineer. This programme shall be communicated to the electrical subcontractor as well as the other specialist subcontractors to enable them to programme accordingly.

The programme shall be in the form of a Gantt chart and shall include the following details:

- Staggered occupation of the site.
- A work breakdown structure, identifying the major activity groups.
- For each activity group further details shall be provided with regard to the scheduled start and end dates of individual activities.
- The linkages between activities shall be clearly indicated and the logical network upon which the programme is based shall be separately submitted to the engineer if requested. Any constraints shall be classified as being time-related or resource-related.
- The critical path(s) shall be clearly indicated and floats on non-critical activities shall be shown.
- The Contractor shall indicate the working hours per day, night, week and month allowed for in the programme.
- Where relevant the Contractor shall state the production rates for key activities, e.g. earthworks, etc.
- For each activity, a statement of how the Contractor plans to do the work identifying the principal equipment and other resources which he plans to use.
- The execution of the work must be programmed in such a manner as to limit disruption to passing traffic and residents to a minimum.
- The programme shall make allowance for the following:
 - (i) All special non-working days
 - (ii) The expected delays resulting from inclement weather.

- (iii) The contract period of eighteen (18) months.
- (iv) Accommodation of traffic and pedestrians.
- (v) Access by public to residences and businesses.
- (vi) Haul distances to Municipal dump sites or stockpile sites.
- (vii) Peak hour traffic congestion.
- (viii) Events, exams and the other functions at the University and schools in the area.
- (ix) Co-ordination of the contractor's works programme with that of the BE and specialist subcontractors.
- (x) Interaction between service providers, moving or protection of services and the construction of surfaced bypasses.

Any other restrictions regarding access to certain parts of the site or commencement of activities stated in these specifications shall be incorporated in the contractor's programme of work. Together with the programme as detailed above the Contractor shall submit to the Engineer a cash flow projection, indicating projected monthly invoice amounts. This have to be done for each of the projects identified within the limits of the tender. The cash flow projection shall be updated at monthly intervals to reflect actual payments to date and anticipated further payments.

The programme will be reviewed at the monthly site meetings at which the Contractor shall provide sufficient detail that will allow the comparison of completed work per activity that has fallen behind. The updated programme shall be submitted to the Engineer at least two days prior to the monthly meetings. If the programme has to be revised by reason of the Contractor falling behind his programme, he shall produce a revised programme showing how he intends to regain lost time in order to ensure completion of the Works within the time for completion as defined in Clause 5.12 of the General Conditions of Contract or any granted extension of time.

Any proposal to increase the tempo of work must be accompanied by positive steps to increase production by providing more labour and plant on site, or by using the available labour and plant on site, or by using the available labour and plant in a more efficient manner. He shall also communicate his intention to all other stakeholders including the electrical, landscaping and traffic lights subcontractors. Failure on the part of the Contractor to submit the programme or to work according to the programme or revised programmes shall be sufficient reason for the Engineer to take steps as provided in Clause 5.16 of the General Conditions of Contract.

The approval by the Engineer of any programme shall have no contractual significance other than that the Engineer will be satisfied that the work is carried out according to such programme and that the Contractor undertakes to carry out the work in accordance with the programme. It shall not limit the right of the Engineer to instruct the Contractor to vary the programme if required by circumstances. The Contractor is also referred to Clause 5.6 of the General Conditions of Contract when drawing up his programme.

C3.5.1.6 Format of communications

The Engineer will set standards specific to the project for communications.

C3.5.1.7 Key personnel

A schedule of key personnel / schedule of contact particulars of key personnel will be requested by the

Engineer with the commencement of the specific project.

C3.5.1.8 Management meetings

C3.5.1.8.1 Community participation

Community participation consists of engagement of Project Steering Committees (PSC). A PSC will be established by the Ward Councillor. The functions of the PSC will be to:

- Assist in monitoring the project.
- Ensure that the community provide assistance to the contractor to ensure that he can execute the contract in accordance with the specifications and within time.
- Encourage the community to participate in the Labour-Intensive construction.
- Identify skills, skilled personnel and suppliers in the towns.

The PSC will not have the power to:

- Give any instructions to the contractor, except through the engineer.
- Become involved in the daily operations of the contractor or interfere with the contract works.

A monthly meeting will be held with the PSC to discuss relevant matters. The site agent and resident engineer will attend the meetings. The contractor will have to report on progress, deviations from the programme, financial matters community related aspects, general problems and co-operation at the meeting. The PSC members will not receive any remuneration for attending, and they must provide their own transport.

C3.5.1.9 Daily records

The requirements for daily records of resources (people and equipment employed) / site diaries in respect of work performed on the site and where such documents are to be held will be set for the project.

C3.5.1.10 Bonds and guarantees

Requirements for guarantees will be stated in the appointment letter for the contract.

C3.5.1.11 Payment certificates

Requirements for substantiation of claims in payment certificates will be as arranged by the Engineer.

C3.5.1.12 Wayleaves

Required where applicable.

C3.5.1.13 Proof of compliance with law

Specific documents/methods for compliance with any legislation will be verified on commencement of the work.

C3.5.2 ENVIRONMENT

1. INTRODUCTION

The EMPr have been prepared which will address the environmental impacts during the design, construction and operational phases of a project. Section 28 of NEMA put a duty of care to the project proponent to ensure that the proposed development does not impact negatively the receiving environment, Due thisas such, due regard must be given to environmental protection during the entire road project. In order to achieve this, a number of environmental specifications/recommendations are made. These are aimed at ensuring that the Contractor maintains adequate control over the project in order to:

Minimise the extent of impact during construction, ensure appropriate restoration of areas affected by construction. Prevent long term environmental degradation. The contractor must be made aware of the environmental obligations that are stipulated in this document, and declares himself/herself to be conversant of all relevant environmental legislation. The Contractor should also be aware that the Engineer and the appointed Environmental Control Officer (ECO) will monitor the implementation of the procedures.

2. POLICY STATEMENT

The construction will be to the best management practices as identified to minimize the environmental impact of activities associated with the development.

3. OBJECTIVES OF EMPr

The EMPr has the following goals:

- Identifying those construction activities that may have a detrimental impact on the environment;
- Detailing the mitigation measures that will need to be taken, and the procedures for their implementation;
- Establishing the reporting system to be undertaken during the construction.

The EMP also serves to highlight specific requirements that will be monitored during the development and should the environmental impacts not have been satisfactory prevented or mitigated; corrective action will have to be taken. The document should, therefore, be seen as a guideline that will assist in minimising the potential environmental impact of activities.

4. DESIGNATED ENVIRONMENTAL OFFICER

For the purpose of the EMP, a nominated representative of the Contractor should be the designated environmental officer for the project. The nominated representative of the Contractor will therefore be responsible for ensuring that the provisions of the EMP are complied with. The Engineer will be responsible for issuing instructions to the Contractor where environmental considerations call for action to be taken. The environmental officer will submit monthly reports to the Engineer and ECO on site who will verify the information.

5. LEGAL REQUIREMENTS

Under normal circumstances an EMP would be the end result or the final stage in the EIA procedure. However, a working agreement was negotiated between the National Department of Environmental Affairs and Tourism (DEAT) and the City of Tshwane Metropolitan Municipality. The agreement stipulates the project types the City of Tshwane Metropolitan Municipality need to submit to DEAT for approval and those project types the City of Tshwane Metropolitan Municipality do not need to submit for approval.

For those actions that do not need approval, the City of Tshwane Metropolitan Municipality undertook to compile site specific EMP's to assist to minimising degradation to the area. The following project types fall in this non-approval category: periodic maintenance, special maintenance, rehabilitation and specific upgrades.

No environmental authorisation is required for the work as described in this document.

6. MITIGATION MEASURES

In setting mitigation measures, the practical implications of executing these measures must be borne in mind. With early planning, both the cost and the impacts can be minimised.

6.1 Establishment of site offices

6.1.1 Site Plan

The Contractor shall provide the Engineer on site with a plan detailing the layout of site offices facilities, such as chemical toilets, areas for stockpiling of material, storage of hazardous materials and provision of containers. The site offices should not be sited in close proximity to steep areas as this will increase soil erosion.

Preferred locations would be flat areas along the route. If the route traverses water courses, streams and rivers, it is recommended that the site, and in particular the ablution facilities, aggregate stockpiles and hazardous material stockpiles are located as far away as possible from any water course as possible.

The site plan shall be submitted before the site hand over meeting. Read with Standard Specifications for Municipal Civil Engineering Works: Section 001 and 002.

6.1.2 Vegetation

The vegetation surrounding the site offices is to be left as intact as possible and vegetation planted at the site should be indigenous. Only trees directly affected by the works and such others as may be indicated by the Engineer in writing may be sawn off/removed.

The project specification for the rehabilitation of the grass cover shall be strictly adhered to. Any proclaimed weed or alien invader plant shall be cleared by hand before seeding. Read with Specifications: 104 – Landscaping and grassing.

6.1.3 Rehabilitation

The site offices will require rehabilitation at the end of the contract. All construction material, including concrete slabs and braai areas are to be removed from the site on completion of

the contract. Read with Sections 001, 002 and 104 of the Specifications.

6.1.4 Water for human consumption

Water for human consumption must be tested and treated in accordance with recommendations.

6.2 Sewage treatment

Adequate toilet facilities are to be provided. Use of the veld for this purpose shall not, under any circumstances, be allowed. The Contractor shall be entirely responsible for enforcing their use and for maintaining such latrines in a clean, orderly and sanitary condition to the satisfaction of the Engineer. Latrines shall be positioned within walking distance from wherever employees are employed on the works.

Safe and effective sewage treatment will require one of the following sewage handling methods: septic tanks and soak always, dry composting toilets such as "enviro loos", or the use of chemical toilets which are supplied and maintained by a subcontractor.

The type of sewage treatment will depend on the geology of the area selected, the duration of the contract and proximity (availability) of providers of chemical toilets is to be done in consultation with the Site Engineer. Read with Sections 104 of the Specifications.

6.3 Waste management

Waste management and waste minimisation must be implemented at the outset of the contract.

6.3.1 Litter

No littering by construction workers is allowed. During the construction period, the facilities shall be maintained in a neat and tidy condition and the site is to be kept free of litter. Read with Sections 001 and 002 of the Specifications.

6.3.2 Removal of solid waste

Solid waste is to be stored in an appointed area for collection and disposal. A refuse control system must be established for the collection and removal of refuse to the satisfaction of the Engineer. Disposal of solid waste will be in a Department of Water Affairs and Forestry (DWAF) licensed landfill site.

6.3.3 Hazardous waste

Hazardous waste such as bitumen, tar, oils, etc. shall be disposed of in a Department of Water Affairs and Forestry approved landfill site. Special care must be taken when using tar products such as tar prime or pre-coating fluid to avoid water-soluble phenols form entering the ground or contaminating water.

6.4 Soil management

6.4.1 Topsoil

The contract provides for the stripping and stockpiling of topsoil from the site for later reuse. Topsoil is considered to be of a minimum thickness of + 300 mm of the natural soil, including all the vegetation and organic matter.

The areas to be cleared of topsoil shall include the storage areas. Weeds appearing on the stockpiled topsoil shall be removed by hand before seeding. Soils contaminated by hazardous substances shall be disposed of in an approved Department of Water and Sanitation waste disposal site.

6.4.2 Borrow material

The Contractor's attention is drawn to the requirements set forth by the Department of Mineral and Energy in terms of the submission of EMPR's for establishment; operation and rehabilitation of borrow pits and quarries.

The cost of complying with the requirements shall be deemed to be included in existing rates in the schedule of quantities. Read with the Specification Section 203.

6.5 Discovery of archaeology sites, artefacts or graves

6.5.1 Archaeology sites

If an artefact on site is uncovered, work in the immediate vicinity must be stopped immediately.

The Contractor shall take reasonable precautions to prevent any person from removing or damaging any such article and shall immediately upon discovery thereof inform the Engineer of such discovery. The National Monuments Council must be contacted who will appoint and archaeological consultant. Work may only resume once clearance is given in writing by the archaeologist. Read with General Conditions of Contract.

6.5.2 Graves

If a grave on site is uncovered, work in the immediate vicinity must be stopped and an undertaker as well as the National Monuments Council should be contacted. The undertaker will place advertisements in the newspapers concerning the grave. He will also provide for the relocation of bones, should it be necessary. Read with General Conditions of Contract.

6.6 Stockpiled material

The Contractor shall so plan his activities that materials excavated from borrow pits and cuttings, in so far as possible, can be transported direct to and placed at the point where it is to be used. However, should temporary stockpiling become necessary, the areas for the stockpiling of excavated and imported material must be indicated and demarcated on the site plan and approved in writing by the engineer.

The area chosen shall be devoid of indigenous trees and shrubs. Care shall be taken to

preserve all vegetation in the immediate area of these temporary stockpiles. After the stockpiled material has been removed, the site shall be reinstated as closely as possible to its original condition. All areas affected by stockpiling shall be landscaped, top soiled and grassed to the Engineer's approval and at the Contractor's cost.

Material milled out of the existing road surface that is temporarily stockpiled within the road reserve shall:

- be stockpiled so as to be as inconspicuous as possible
- be prevented from contaminating water courses,
- be cleared of weeds.

In all cases, the areas for stockpiling and disposal of construction rubble shall be approved by the Engineer before such operation commences. Read with Section 203 of the Specifications.

6.7 Fuel, diesel and other hazardous materials

6.7.1 Hazardous Materials

All hazardous materials i.e. bitumen binders shall be stored in an appointed area that is fenced and has restricted entry. Storage of bituminous products shall only take place using suitable containers to the approval of the Engineer.

Under no circumstances shall the spoiling of bituminous products on the site, over embankments, in borrow pits or any burying, be allowed. Unused or rejected bituminous products shall be taken to the supplier's production plant. No spillage of bituminous products shall be allowed on site. Affected areas shall be promptly reinstated to the satisfaction of the Engineer.

6.7.2 Fuel

Should any fuel storage tank be required on site, the Contractor shall ensure that he has complied with the necessary legal requirements for the erection of such tanks. Leakage must be avoided. The fuel and diesel areas should be bonded to accommodate any spillage or overflow from these activities.

6.7.3 Oil, grease

Oil, grease and cleaning materials from the maintenance of vehicles and machinery shall be collected in a sump and sent back to the supplier or, otherwise disposed of at a registered site.

6.7.4 Cooking oil

The Contractor should ensure that sufficient fuel is available for heating and cooking purposes should this be necessary.

6.7.5 Spillages

Streams, rivers and dams must be protected from direct or indirect spillage of pollutants such

as refuse, garbage, cement, concrete, sewage, chemicals, fuels, oils, aggregate, tailings, wash water, organic materials and bituminous products. In the event of a spillage, prompt action must be taken by competent instances to clear the affected area.

6.8 General conditions

Complaints received regarding activities on the construction site pertaining to the environment shall be recorded in a designated register and the response noted with the date and action taken. This record must be submitted with the monthly reports.

Any avoidable non-compliance with the above-mentioned measures may be considered sufficient ground for withholding payment of part or all amounts to be paid for the said item.

7. MEASUREMENT AND PAYMENT

The Contractor shall not be separately reimbursed or compensated in respect of his compliance with the provisions of this part of the Scope of Works. All costs so incurred shall, save and except to the extent provided for the schedule of quantities under SECTION 001: GENERAL REQUIREMENTS AND CHARGES, be deemed to be included in the rates tendered for the various items of work listed in the schedule of quantities.

TABLE 1 SUMMARY OF MITIGATION MEASURES

ENVIRONMENTAL COMPONENT	ACTIVITY	MITIGATION	RELEVANT SECTION IN SPECIFICATIONS
Establishment of site offices	Siting of offices	Avoid steep areas as soil erosion could increase. Avoid water courses	001 002.02.01
	Site Plan	Contractor will provide engineer detail of layout of site facilities within two weeks of moving to the site i.e. chemical toilets, the demarcation of areas for stockpiling of materials, storage of hazardous materials and the provision of containers. The offices shall be fenced. The site plan will be submitted before the site hand over meeting.	001 002
Site rehabilitation	Cleanup	All construction material is to be removed from the site on completion of the contract.	001 002 104
Vegetation	On site	Vegetation planted on the site should be indigenous. Only trees directly affected by works as indicated in writing by Engineer, shall be sawn off/removed	104

ENVIRONMENTAL COMPONENT	ACTIVITY	MITIGATION	RELEVANT SECTION/OIN SPECIFICATIONS
	Weeds	Clearance of weeds must be done by hand before seeding.	104
	Grass cover	The grass cover surrounding the construction site is to be left as intact as possible or restored to its original condition.	104
Water	Available for human consumption	Water for human consumption must be tested and treated in accordance with recommendations.	
Soil management	Topsoil	The topsoil (\pm 300 mm) of any excavation shall be removed and stockpiled separately from underlying material in an appointment area	203 104
	Borrow material	EMPR's for borrow pits to be submitted to the Department of Mineral and Energy Affairs for approval	201 203
Archaeological & Cultural sites	Discover of archaeological sites of artefacts	If an artefact on site is uncovered, work in the immediate vicinity must be stopped immediately and an archaeological consultant must be contacted. Work may only resume once clearance is given in writing by the archaeologist.	GCC
Graves	Discovery of graves	If a grave on site is uncovered, work in the immediate vicinity must be stopped and an undertaker should be contacted	GCC
Waste management	Solid & Construction waste	Solid waste is to be stored in an appointment area for collection and disposal. Disposal of waste will be in a DWS licensed landfill, and no waste may be burnt on site.	
	Litter	The site is to be kept free of litter	001
Sewage treatment	Toilet facilities	Adequate toilet facilities are to be provided, and the siting of chemical toilets is to be done in consultation with the site engineer. Use of the veld for this purpose shall not be allowed.	001 002
Fuel, diesel & hazardous materials	Hazardous Materials	All hazardous materials i.e. bitumen binders will be stored in an appointed area that is fenced and has restricted entry. No spoiling of bituminous products on site, over embankments, in borrow pits or any burning. No	

ENVIRONMENTAL COMPONENT	ACTIVITY	MITIGATION	RELEVANT SECTION IN SPECIFICATIONS
		spillage of bituminous products shall be allowed on site.	
	Fuels	All fuel tanks will be stored in an appointed area. Leakage will be avoided.	
	Cooking fuel	The Contractor should ensure that sufficient fuel is available for heating and cooking purposes should this be necessary.	
	Oil, grease	Oil, grease and cleaning materials from maintenance of vehicles shall be collected in a sump and sent back to supplier.	
	Spillages	Streams, rivers or dams must be protected against spillages of pollutants mentioned in 6.7 (e). In the event of a spillage, prompt action must be taken to clear the affected area.	
General considerations	Lines of authority	A nominated representative of the contractor will be the designated environmental officer for the site.	
	Reports	The environmental officer will submit monthly reports to the Engineer who will verify the information	
	Complaints	Complaints received regarding activities on the construction site pertaining to the environment should be recorded in a designated register, and the response noted with the date and action taken. This record must be submitted with the monthly report	

The Site Specific EMPr is appended in C5.1 ENVIRONMENTAL MANAGEMENT PROGRAMME (EMPR)

C3.5.3 HEALTH AND SAFETY

C3.5.3.1 Health and safety requirements and procedures

1. SCOPE

1.1 Scope of specification

This specification covers the principles, duties, responsibilities, liabilities, and requirements applicable in respect of health and safety in the work place on construction work. This document constitutes the Employers' Health and Safety Specification as defined in the Construction Regulations, 2014 of the Occupational Health and Safety Act (Act 85 of 1993).

This specification applies to tunnelling although the minimum requirements for tunnelling are contained in the Mines Health and Safety Act. This specification however does not apply to underground construction at this point in time as covered by the Mines Health and Safety Act, 1996 (Act 29 of 1996) as amended.

1.2 Philosophy

Some of the terms and requirements of the Occupational Health and Safety Act and its Regulations may be novel to Contractors. This specification has therefore been prepared as an instructive guideline without being prescriptive, constraining the competitive advantage or interfering with the legal obligations of the responding parties.

The Health and Safety Plan required in terms of this specification may also be novel to Contractors. This specification has therefore been prepared in such a way to allow Contractors to employ the services of specialist consultants for the preparation and implementation of the same during the construction of the Works.

Health and safety can only be assured on construction works if all stakeholders buy into the Health and Safety plan and when the health and safety of all is an integrated line accountability of all management staff and workers on site. The management systems that are provided for in this specification is to enable the performance statistics of health and safety to be regularly captured, the intention of these systems is not to achieve health and safety by policing the conduct of the Contractor's employees.

In addition to ensuring health and safety, the intention of the management system is rather to commercially exploit the benefit of doing things right the first time that goes hand in hand with top health and safety performance. Accidents and injuries never pay. The loss of production and the cost of injuries, however, relatively infrequent they may be, far outweigh the effort required to maintain top health and safety on construction.

The specification accordingly provides for:

- a) Independent periodic audits to ensure an unbiased pursuit of health and safety,
- b) Follow-up audits to ensure the implementation of prescribed remedial actions,
- c) The review of the efficiency and effectiveness of the Contractor's Health and Safety Plan,
- d) The preparation of regular reports of inspections and accidents to enable the tracking of changes in health and safety performance,
- e) The monitoring of conditions on a continuously pro-active basis to ensure that hazards are without delay identified, assessed and remedied should it threaten the health and safety of persons and property,
- f) Ad hoc inspections to ensure that health and safety is pursued with dedication and not out of intimidation or coercion, and

- g) Development of all aspects of the Contractor's Health and Safety Plan.

The fundamental intention of this specification is that the preservation of health and safety will become a core value of all involved during the construction of the Works.

This Specification does not require the preparation of an unduly extensive or complex risk assessment. The Contractor should rather prepare a risk assessment which takes the size of the project, the size of the Contractor's organization, the conditions of the workplace and the nature, complexity and significance of the hazards likely to be encountered during the execution of the Works into account.

2. INTERPRETATIONS

2.1 Supporting specifications

Where this specification is required for a project, the following specifications (as amended) shall, inter alia, form part of the contract document:

- a) Occupational Health and Safety Act, 1993, and its regulations which shall include, but shall not be limited to the following:
- Construction Regulations, 2014,
 - General Safety Regulations,
 - General Administrative Regulations, 1996,
 - Driven Machinery Regulations, 1988,
 - Electrical Installation Regulations, 1992,
 - Electrical Machinery Regulations, 1988,
 - Environmental Regulations for Workplaces, 1987, and
 - Facilities Regulations, 1990.
- b) Clauses 4.5.2, 4.6, 4.7 and 4.8 of the Contract Data.
- c) Standard Specifications for Municipal Civil Engineering Works, Third Edition 2005, of City of Tshwane Metropolitan Municipality.

2.2 Application

This specification contains clauses that are applicable to the occupational health and safety requirements of the Occupational Health and Safety Act, 1993 and its Regulations, in particular the Construction Regulations, 2014.

2.3 Definitions

In the Contract (as defined in Clause 1.1.1.7 of the Conditions of Contract) the following words and expressions shall have the meanings hereby assigned to them except where the context otherwise requires:

- (a) Assistant Construction Supervisor means a competent person appointed in accordance

- with regulation 6.(2) of the Construction Regulations, 2003, in writing by the Contractor, with written notification to the Engineer.
- (b) Batch Plant Supervisor means a competent person appointed in accordance with regulation 18.(1) of the Construction Regulations, 2003, in writing by the Contractor, with written notification to the Engineer.
 - (c) Construction Health and Safety Officer means a competent person appointed in accordance with regulation 6(6) of the Construction Regulations, 2003, in writing by the Contractor, with written notification to the Engineer.
 - (d) Construction Supervisor means a competent person appointed on a full-time basis in accordance with regulation 6.(1) of the Construction Regulations, 2003, in writing by the Contractor, with written notification to the Engineer.
 - (e) Construction Vehicles & Mobile Plant Inspector means a competent person appointed in accordance with regulation 21.(1)(j) of the Construction Regulations, 2003, in writing by the Contractor, with written notification to the Engineer.
 - (f) Contractor means the natural or juristic person or partnership whose tender has been accepted by or on behalf of the Employer and, who is defined as the Principal Contractor in the Construction Regulations, 2003.
 - (g) Demolition Work Supervisor means a competent person appointed in accordance with regulation 12.(1) of the Construction Regulations, 2003, in writing by the Contractor with written notification to the Engineer.
 - (h) Employer's Designer means the natural or juristic person or partnership named in the Appendix to Tender or any other natural or juristic person or partnership appointed from time to time by the Employer for the design of the portion of the Permanent Works which the Employer is responsible to design in terms of this Contract.
 - (i) Contractor's Designer means the natural or juristic person or partnership appointed from time to time by the Contractor and notified in writing to the Engineer and Employer for the design of the portion of the Permanent Works which the Contractor is responsible to design in terms of this Contract, and for the design of the Temporary Works.
 - (j) Electrical Temporary Installation Inspector means a competent person appointed in accordance with regulation 22. (d) of the Construction Regulations, 2003, in writing by the Contractor, with written notification to the Engineer.
 - (k) Employer means the natural or juristic person or partnership for which the Works are to be executed, who is named as the Employer in the Conditions of Contract and who is known as the "Client", in the Occupational Health and Safety Act, 1993 and its regulations.
 - (l) Engineer means the natural or juristic person or partnership named as the Engineer in the Conditions of Contract and appointed by the Employer to act as the Engineer in terms of this Contract.
 - (m) Engineer's Representative means the person appointed by the Engineer in terms of Clause 1.1.1.1.7 of the Conditions of Contract.
 - (n) Excavation Work Supervisor means a competent person appointed in accordance with regulation 11.(1) of the Construction Regulations, 2003, in writing by the Contractor, with written notification to the Engineer.
 - (o) Explosive Powered Tools Issuer means a competent person appointed in accordance with regulation 19. (2)(g)(i) of the Construction Regulations, 2003, in writing by the Contractor, with written notification to the Engineer.
 - (p) Fall Protection Developer means a competent person appointed in accordance with regulation 8.(1)(a) of the Construction Regulations, 2003, in writing by the Contractor, with written notification to the Engineer.
 - (q) Fire Extinguisher Inspector means a competent person appointed in accordance with

- regulation 27.(h) of the Construction Regulations, 2003, in writing by the Contractor, with written notification to the Engineer.
- (r) Formwork and Support Work Supervisor means a competent person appointed in accordance with regulation 15.(1) of the Construction Regulations, 2003, in writing by the Contractor, with written notification to the Engineer.
 - (s) Hazard means any object, action or condition that can potentially harm the health and safety of persons or property.
 - (t) Hazard Identification means the identification and documenting of existing or expected hazards.
 - (u) Health and Safety Consultant means the natural or juristic person or partnership appointed by the Contractor to assist in any matters related to health and safety on the construction site.
 - (v) Health and Safety Plan means a documented plan, prepared by the Contractor, of work procedures to mitigate, reduce or control hazards identified.
 - (w) Health and Safety Specification means a documented specification of all health and safety requirements and criteria to mitigate reduce or control hazards identified.
 - (x) Health and Safety Representative means the person/s designated in accordance with section 17 of the Occupational Health and Safety Act.
 - (y) Ladder Inspector means a competent person appointed in accordance with regulation 13 of the General Safety Regulations, in writing by the Contractor, with written notification to the Engineer.
 - (z) Material Hoist Inspector means a competent person appointed in accordance with regulation 17.(8)(a) of the Construction Regulations, 2003 in writing by the Contractor, with written notification to the Engineer.
 - (aa) Method Statement means a document detailing the key activities to mitigate, reduce or control hazards identified.
 - (bb) Professional Engineer means any person employed from time to time by either the Employer or Contractor who holds registration as either a Professional Engineer or Professional Certificated Engineer under the Engineering Profession Act, 2000 (Act No. 46 of 2000).
 - (cc) Professional Technologist means any person employed from time to time by either the Employer or Contractor who holds registration as a Professional Technologist under the Engineering Profession Act, 2000 (Act No. 46 of 2000).
 - (dd) Risk means the likely occurrence and impact of a hazard.
 - (ee) Risk Assessment means a programme carried out to identify and evaluate the likely occurrence and impact of all hazards.
 - (ff) Risk Assessor means a competent person appointed in accordance with regulation 7.(1) of the Construction Regulations, 2003, in writing by the Contractor, with written notification to the Engineer.
 - (gg) Safety Agent means a competent natural or juristic person or partnership named in the Appendix to Tender or any other person appointed from time to time by the Employer and notified in writing to the Contractor to act on behalf of the Employer for the purposes of this specification.
 - (hh) Scaffolding Supervisor means a competent person appointed in accordance with regulation 14.(2) of the Construction Regulations, 2003, in writing by the Contractor, with written notification to the Engineer.
 - (ii) Stacking Supervisor means a competent person appointed in accordance with regulation 26.(a) of the Construction Regulations, 2003, in writing by the Contractor, with written notification to the Engineer.

- (jj) Subcontractor means the natural or juristic person or partnership who is appointed by the Contractor with prior consent of the Engineer to execute certain tasks associated with the Works and who is also an employer as defined in section 1 of the Occupational Health and Safety Act.
- (kk) Suspended Platforms Supervisor means a competent person appointed in accordance with regulation 15.(1) of the Construction Regulations, 2003, in writing by the Contractor, with written notification to the Engineer.

2.4 Duties, responsibilities and liabilities

2.4.1 Principal parties

This section covers the duties, responsibilities and liabilities of the following principal parties:

- Employer
- Employer's Safety Agent
- Contractor
- Subcontractor
- Employer's Designer
- Contractor's Designer

The duties and responsibilities of the various principal parties are briefly summarized below (the numbers indicated correspond to the applicable regulation number in the Construction Regulations, 2003). The intention of the summary is not to replace the Regulations, but is included for indicative purposes. The liabilities of each party are also shown.

- a) Employer
In addition to the duties, responsibilities and liabilities specified in the Conditions of Contract, the Employer shall have the following duties and responsibilities to ensure compliance with the Construction Regulations, 2003:
 - 4. (1) (a) Prepare health and safety specifications for the Works.
 - 4. (1) (a) Provide copies of the specifications to Tenderers or to the appointed Contractor.
 - 4. (1) (b) Provide any information to the Contractor that may affect the health and safety of his employees.
 - 4. (1)(c) Appoint the Contractor in writing for the Works.
 - 4. (1)(d) Take reasonable steps to ensure that the Contractor's Health and Safety Plan is implemented and maintained on the Works (which shall include monthly audits).
 - 4.(1)(e) Stop the Contractor from executing work, not in accordance with, his Health and Safety Plan or which poses a threat to the health and safety of persons.
 - 4.(1)(f) Ensure that sufficient health and safety information and appropriate resources are made available to the Contractor when changes are brought about to the design.
 - 4.(1)(g) Ensure that the Contractor is registered and in good standing with the compensation fund or with a licensed compensation insurer prior to the commencement of the Works.
 - 4.(1)(h) Ensure that Tenderers have made provision in their tenders for the cost of health and safety measures during the construction of the Works.
 - 4.(2) Discuss and negotiate the contents of the Contractor's Health and Safety Plan.
 - 4.(2) Approve the Contractor's Health and Safety Plan for implementation.

- 4.(3) On request, make available copies of the Contractor's Health and Safety Plan to his employees, his Subcontractors and inspectors.
- 4.(4) Satisfy himself on the competencies and resources of the Contractor he intends appointing.
- 4.(6) Satisfy himself on the competencies and resources of his Safety Agent should he decide to appoint one.

In terms of Clause 4.3 of the Contract Data, the Contractor accepts sole liability as mandatory for due compliance with the Occupational Health and Safety Act, 1993 and all its regulations including the Construction Regulations, 2003.

The Employer will only be responsible for the duties imposed on the Employer in terms of the Construction Regulations, 2003 as listed above.

b) Employer's Safety Agent

Where the Employer decides to appoint an agent in accordance with regulation 4.(5) of the Construction Regulations, 2003, the duties and responsibilities as imposed by these regulations upon the Employer shall as far as reasonably practicable apply to his Safety Agent. This agent shall be required to attend the monthly site meetings.

c) Contractor

In addition to the duties, responsibilities and liabilities specified in the Conditions of Contract, the Contractor shall have the following duties and responsibilities to ensure compliance with the Construction Regulations, 2003:

- 3.(1)(a) Notify the provincial director in writing of the commencement of the construction works.
- 3.(3) Ensure that a copy of the notification letter is kept on site for inspection on request as well as proof of its receipt by the Department of Labour.

5.(1) Demonstrate a Health and Safety Plan, based on the Employer's health and safety specifications.

5.(1) Apply the Health and Safety Plan from the Commencement Date until completion of the Works.

5.(2) Ensure co-operation between all contractors to enable each to comply with the provisions of Construction Regulations.

5.(3)(a) Provide any Tenderer or Subcontractor with copies of the Employer's health and safety specifications.

5.(3)(b) Appoint Subcontractors in writing.

5.(3)(c) Ensure that each Subcontractor's Health and Safety Management Plan is implemented and maintained on their portion of the Works.

5.(3)(d) Stop any Subcontractor from executing Works, not in accordance with, the Contractor's Health and Safety Plan or which poses a threat to the health and safety of persons.

5.(3)(e) Ensure that sufficient health and safety information and appropriate resources are made available where applicable, to the Subcontractor when changes are brought about to the design of the Works.

5.(3)(f) Ensure that his Subcontractor is registered and in good standing with the compensation fund or with a licensed compensation insurer prior to the commencement of the Works.

5.(3)(g) Ensure that his Tenderers have made provision in their tenders for the cost of health and safety measures during the construction of the Works in line with the requirements of the Employers Health and Safety Specification and his Health and Safety Management Plan.

5.(5) Discuss and negotiate the contents of his Subcontractor's Health and Safety Plan, to ensure compliance with the Employer's Health and Safety Specification and consistent with the Contractors Health and Safety Management Plan.

5.(5) Approve his Subcontractor's Health and Safety Plan for implementation and to keep records of all such approvals on site for auditing purposes.

5.(6) On request, make available a copy of his and his Subcontractor's Health and Safety Plan to an employee, inspector, contractor, the Employer or the Employer's Safety Agent.

5.(7) Open and maintain a record management system regarding health and safety for the Contractors own and Subcontractors' Health and Safety Documentation on the construction site.

5.(7) Upon request, make available his health and safety record management system to an inspector, Employer, the Employer's Safety Agent or the Contractor.

5.(8) Deliver the health and safety record management system to the Employer upon completion of the Works.

5.(9) Ensure that a comprehensive and updated list of all his Subcontractors (including their respective subcontracting agreements) are included in the health and safety record management system.

5.(10) Satisfy himself on the competencies and resources of the Subcontractor he intends appointing.

6.(1) Appoint a construction supervisor.

6.(3) Appoint assistant construction supervisors if required by an inspector.

6.(5) Appoint individual construction supervisors for individual construction sites.

6.(6) The Contractor shall after due consideration of the complexity, size and potential hazards and associated risks as well as controls towards the mitigation of risks, appoint a safety officer in writing. The contractor shall submit a detailed CV of the envisaged Safety Officer appointment for final acceptance thereof by the Employer or his Safety Agent.

6.(7) Provide opportunities to the construction safety officer to provide inputs into the Health and Safety Plan.

6.(8) Satisfy himself with the competencies and resources of the construction safety officer he intends appointing.

7.(1) Perform a risk assessment prior to the commencement of any construction work.

7.(2) On request, make available copies of the his/her risk assessment.

7.(3) Consult with the health and safety committee on the development, monitoring and review of the risk assessment.

7. (4) Ensure that all employees are informed, instructed and trained regarding any hazard and the related work procedures before any work commences. The contractor shall ensure that proof of such is available on site for auditing purposes.

7.(5) Ensure that all Subcontractors are informed regarding any hazard as stipulated in the risk assessment. Further that Subcontractor conduct their own risk assessments as and when required

7.(6) Analyze ergonomic related hazards and address the same in the risk assessment.

7.(7) Ensure that all employees undergo health and safety induction prior to permitting each employee access to the Works. The Contractor shall ensure that proof of such is available on site

for auditing purposes.

7.(8) Ensure that all visitors undergo health and safety induction and are provided with the necessary personal protective equipment. The Contractor shall ensure that proof of such is available on site for auditing purposes.

7.(9) Ensure that every employee is in possession and carries at all times his proof of health and safety induction training.

9.(1)(a) Prevent the uncontrolled collapse of any structure which may become unstable due to the carrying out of construction work.

9.(1)(b) Ensure that no structure is loaded in an unsafe manner.

9.(3) Ensure that all construction drawings are on site and available on request by an inspector, contractors, Employer, the Employer's Safety Agent or employee.

In terms of Clause 4.3 of the Contract Data, it shall be deemed that the parties to this Contract have agreed in writing in terms of Section 37(2) of the Occupational Health and Safety Act, 1993 that the Contractor accepts sole liability for due compliance with the relevant duties, obligations, prohibitions, arrangements and procedures imposed by the Occupational Health and Safety Act, 1993 and all its regulations, including the Construction Regulations, 2003, for which he is liable as mandatory.

d) Subcontractor

To ensure compliance with the Construction Regulations, the Subcontractor shall: 5.(4) Demonstrate a Health and Safety Plan, based on the Employer's health and safety specification.

5.(4) Apply his Health and Safety Plan from the Commencement Date and until completion of the Works.

5.(12) Satisfy himself on the competencies and resources of any Subcontractor he intends appointing.

5.(14) Provide the Contractor with any information which might affect the health and safety of any person or which might justify a review of the Health and Safety Plan.

In addition to the above items, the Subcontractor shall, to ensure compliance with the Construction Regulations, comply with regulations 5.7, 6.(1), 6.(3), 6.(5), 6.(6), 6.(7), 6.(8), 7.(1), 7.(2), 7.(3), 7.(4), 7.(6), 7.(7), 7.(8), 7.(9), 9.(1)(a), 9.(1)(b) and 9.(3), summarized in Section 2.4.1(c) above.

e) Designer (Employer's Designer or Contractor's Designer)

To ensure compliance with the Construction Regulations, 2003, the Designer (as defined in the Construction Regulations, 2003) shall:

9.(2) Make available to the Employer all relevant information affecting the pricing of the Works.

9.(b) Inform the Contractor of any hazards relating to the Works.

9.2(b) Make available all information required for the safe execution of the Works.

9.2(c) Ensure that information relating to geo-sciences, designs loads, and the methods and sequencing of construction processes are made available to the Contractor in a report.

9.2(d) Not include dangerous procedures or hazardous materials in the structure's design which could be avoided.

9.2(e) Make provision in the design of the Works for hazards likely to be encountered during its subsequent maintenance.

9.2(f) Carry out inspections of the construction work during the construction period to ensure compliance with the designs.

9.2(f) Keep records of the inspections carried out on the construction site.

9.2(g) Stop any contractor from executing works not in accordance with the designs.

9.2(h) Conduct a final inspection of the completed Works prior to its commissioning.

9.2(h) Issue a completion certificate to the Contractor subsequent to a successful final inspection.

9.2(i) Ensure that cognizance is taken of ergonomic design principles in order to minimize related hazards.

The Employer's Designer shall only accept responsibility to comply with the Construction Regulations, 2003 for that portion of the Permanent Works which the Employer is responsible to design in terms of the Contract. The Contractor's Designer shall accept sole responsibility and liability to comply with the Construction Regulations, 2003 for that portion of the Permanent Works for which the Contractor is responsible to design in terms of the Contract as well as the design of the Temporary Works.

2.4.2 Secondary parties

This section covers the duties, responsibilities and liabilities of the following secondary parties:

- Construction Health and Safety Officer
- Contractor's Employees
- Fall Protection Developer
- Health and Safety Consultant
- Health and Safety Representative
- Risk Assessor

a) Construction Health and Safety Officer

The Construction Health and Safety Officer will act as Health and Safety advisor to the site management staff, ensuring the integrity of the Safety management System and Plan and its implementation. The Construction Health and Safety Officer can therefore never take over the line management responsibilities for safe work practices.

The Contractor is responsible for the development of the position outcomes descriptors for the Construction Health and Safety Officer. This documentation shall be available on site for auditing purposes. The Construction Health and Safety Officer shall if given an opportunity, provide an input into the Contractor's Health and Safety Plan.

b) Contractor's Employees

All employees will be responsible for safety on the construction site and the work place as prescribed in section 14 of the Occupational Health and Safety Act, 1993 and briefly summarized as follows:

- Take reasonable care for the health and safety of himself and of other persons who may be affected by his acts,

- Co-operate with his employer with regards to health and safety to ensure that his employer complies with requirements imposed on him,
- Obey the health and safety rules and procedures laid down by his employer,
- Report any unsafe or unhealthy situation to his employer or to the health and safety representative for his workplace,
- Immediately report any incident in which he was involved which has caused an injury to himself or others, and
- Assist in inquiries and incident investigations.

No employee shall intentionally or recklessly interfere with, damage or misuse anything which is in the interest of health and safety

c) Fall Protection Developer

The Fall Protection Developer will be responsible for the preparation and maintenance of a fall protection plan to be implemented by the Contractor, in such a manner to ensure compliance with regulation 8 of the Construction Regulations, 2003.

d) Health and Safety Consultant

The Health and Safety Consultant shall assist the Contractor in any health and safety matters on the Works for which he is appointed.

e) Health and Safety Representative

The Health and Safety Representative shall fulfil the duties as set out in section 18 of the Occupational Health and Safety Act, (Act 85 of 1993). A health and safety representative shall not incur any civil liability by reason of the fact only that he failed to do anything which he may do or is required to do in terms of the Act.

f) Risk Assessor

The Risk Assessor shall facilitate the risk assessment process of the Contractor or Subcontractor. The Risk Assessor shall be responsible for the compilation and implementation of a management plan towards the continuous mitigation of identified risks to as low as is reasonable practicable.

2.4.3 Supervisors, inspectors and issuers

This section covers the duties, responsibilities and liabilities of the following Supervisors, Inspectors and Issuers likely to be found on the Works:

a) Batch Plant Supervisor

The Batch Plant Supervisor shall be required to ensure compliance with regulation 18 of the Construction Regulations, 2003. In addition, he shall fulfil the following duties and responsibilities:

- Manage the day to day operation of a batch plant,

- Be responsible for the maintenance of the batch plant,
- Be able to identify developing defects and hazardous situations,
- Act as the Occupational Health and Safety Representative at the batch plant, and
- Take responsibility for the safety of the personnel at the batch Plant.

The Batch Plant Supervisor will have the authority to stop operation of the plant should any hazardous situation require it.

b) Construction Supervisor

The Construction Supervisor shall be responsible for supervising the construction work inclusive of the implementation and maintenance of safe work practices.

c) Construction Vehicle & Mobile Plant Inspector

The Construction Vehicle and Mobile Plant Inspector will ensure the safety of all construction vehicles and plant in such a manner to ensure compliance with regulation 21 of the Construction Regulations, 2003. The inspector will also be responsible for the regular inspection of all vehicles and plant and the recording of his findings. The Contractor shall ensure that proof of such is available on site for auditing purposes.

d) Demolition Work Supervisor

The Demolition Work Supervisor will supervise and control all demolition work on the Works in such a matter to ensure compliance with regulation 12 of the Construction Regulations, 2003. The supervisor will be responsible for all administration related to the demolition works. The Contractor shall ensure that proof of such is available on site for auditing purposes.

e) Electrical Temporary Installation Inspector

The Electrical Temporary Installation Inspector will control all temporary electrical installations on the Works to ensure compliance with regulation 22 of the Construction Regulations, 2003, the Electrical Installations Regulations, 1992 and SANS 0142. The Contractor shall ensure that proof of such is available on site for auditing purposes.

f) Excavation Work Supervisor

The Excavation Work Supervisor will supervise all excavation work on the Works in such a matter to ensure compliance with regulation 11 of the Construction Regulations, 2003 and shall in particular ensure that every excavation is inspected:

- On a daily basis before each shift,
- After every blasting operation,
- After an unexpected fall of ground,
- After substantial damage to supports, and
- After rains.

The Contractor shall ensure that proof of such is available on site for auditing purposes.

g) Explosive Power Tools Issuer

The Explosives Power Tools issuer will control the issuing and collection of explosive tools, cartridges and nails or studs to ensure compliance with regulation 19 of the Construction Regulations, 2003. The Contractor shall ensure that proof of such is available on site for auditing purposes.

h) Fire Extinguisher Inspector

The Fire Extinguisher Inspector will be responsible for the operation and inspection of all fire fighting equipment on the Works to ensure compliance with regulation 27 of the Construction Regulations, 2003. The Contractor shall ensure that proof of such is available on site for auditing purposes.

i) Formwork and Support Work Supervisor

The Formwork and Support Work Supervisor will supervise all formwork and support work operations and will see to it that formwork and support work erectors, operators and inspectors are competent to carry out their work Works to ensure compliance with regulation 10 of the Construction Regulations, 2003. The Contractor shall ensure that proof of such is available on site for auditing purposes.

j) Ladder Inspector

The Ladder Inspector will be responsible for the regular inspection and recording of his/her findings of all ladders on the Works and to ensure compliance with regulation 13 of the General Safety Regulations. The Contractor shall ensure that proof of such is available on site for auditing purposes.

k) Material Hoist Inspector

The Material Hoist Inspector will be responsible for the daily inspection of material hoists or similar machinery and to ensure Works to ensure compliance with regulation 17 of the Construction Regulations, 2003. The inspector must have experience pertaining to the erection and maintenance of all hoists on the Works. The inspector must be able to determine the serviceability of the entire material hoist including guides, ropes and their connections, drums, sheaves or pulleys and all safety devices. The Contractor shall ensure that proof of such is available on site for auditing purposes.

l) Scaffolding Supervisor

The Scaffold Supervisor will be required to supervise all scaffolding work operations carried out on the Works and to ensure compliance with regulation 14 of the Construction Regulations, 2003 as well as ensure compliance with applicable SABS 085 specifications. The Contractor shall ensure that proof of such is available on site for auditing purposes.

m) Stacking Supervisor

The Stacking Supervisor shall supervise the stacking and storage of all articles on site and shall be responsible to ensure compliance with regulation 26 of the Construction Regulations, 2003.

n) Suspended Platform Supervisor

The Suspended Platform Supervisor will supervise all suspended platform work operations carried out on the Works and to ensure compliance with regulation 15 of the Construction Regulations, 2003. The supervisor will also see to it that all suspended platform erectors, operators and inspectors are competent to carry out their work. The Contractor shall ensure that proof of such is available on site for auditing purposes.

3. GENERAL REQUIREMENTS OF HEALTH AND SAFETY PLAN

3.1 General

It will be expected from the Contractor to include in his safety plan method statements on how to accomplish the requirements relating to the Construction Regulations, 2003 and related incorporated standards and regulations. Contractors should describe how their safety management systems will work and what control procedures they plan on using to ensure safety on the construction site. The following generic aspects should be covered in their safety plan:

- What administrative procedures the Contractor envisages to use in the implementation and maintenance of the safety plan with reference to the construction site
- How continuous assessment of the safety plan will be assessed and implemented with respect to construction site
- What control systems the Contractor envisages to implement on site to support his safety program
- How the Contractor will ensure that he adheres to the construction regulations in respect of competent persons for appointments
- What external resources the Contractor envisages on using to ensure successful implementation and sustainability of the safety plan
- What training to employees the Contractor envisages and how he would go about to execute it
- The Contractor should indicate which competent persons he plans on employing

During the tendering phase it will be expected from the tenderer to briefly explain how the abovementioned will be accomplished. Once a successful tenderer has been appointed, the Contractor shall supply a detailed Health and Safety Plan for review by the Employer, prior to site mobilization, to ensure compliance with the Construction Regulations, 2003. Mobilization shall be dependent upon the acceptance of the Contractor's Health and Safety Management Plan by the Employer. The Contractor's Health and Safety Plan should include, but not be limited to, those sections indicated in Section 3.2 of this specification.

3.2 Outline of Health and Safety Plan

The Contractor's Health and Safety Plan prepared in accordance with this specification shall consist of at least the following sections and sub-sections:

1. Aim and Scope of Plan,
2. Risk Assessment,

- a. Alternative Forms of Risk Assessment,
- b. Methodology of Risk Assessment,
- c. Elements of Risk Assessment,
 - i. Scope of assessment,
 - ii. Risks Identified,
 - iii. Risk Analysis,
 - iv. Risk Evaluation,
 - v. Risk Treatment,
 - vi. Monitoring and reviewing,

3. Resources,
 - a. Health and Safety Staffing Organogram,
 - b. Supervisors, Inspectors and Issuers,
 - c. Employees,
 - d. Subcontractors inclusive of their scope of work and their core resources,
 - e. Training,
 - f. Plant,
 - g. Vehicles,
 - h. Equipment

4. Materials,
 - a. Temporary Materials
 - b. Permanent Materials

5. Categories of Work

6. Implementation of Health and Safety Plan,
 - a. Administrative systems,
 - b. Training,
 - c. Reporting,
 - d. Monitoring,
 - e. Inspections,

7. Auditing,
 - a. Internal audits,
 - b. Follow-up audits,

8. Financial Aspects,

9. Emergency procedures and response

4. RISK ASSESSMENT

4.1 General

This section of the specification provides guidelines for the Contractor in preparation of risk assessments in order to ensure compliance with Regulation 7 of the Construction Regulations, 2003. This section highlights the principles related to the preparation of suitable and sufficient risk assessments. Contractor Staff intending to prepare risk assessments should be trained and suitably

experienced in the application envisaged.

A suitable and sufficient risk assessment is an assessment which:

- Accounts for risks that are likely to arise during the construction of the Works,
- Enables the development and implementation of systems to manage the risks,
- Remains valid for a reasonable period of time,
- Provides a basis for training of employees, and
- Improves working procedures and introduce long term controls.

The requirements of the Construction Regulations will not be satisfied by a single risk assessment exercise that holds good for all time. The risk assessment process on the Works is an ongoing process.

The objectives of risk assessments are to:

- Identify the risks that are mostly in need of reduction,
- Identify the various options for achieving such reduction,
- Identify the risks that require careful ongoing management, and
- Identify the nature of the required ongoing attention.

4.2 Forms of risk assessment

In order to ensure compliance with the Construction Regulations, the Contractor will be required to carry out the following three forms of risk assessment.

4.2.1 Baseline or datum risk assessments

The Contractor will be required carry out a risk assessment before the commencement of construction activities on the Works. This “baseline” or “datum” risk assessment will form part of the Contractor’s Health and Safety Plan.

The risks and hazards to which persons, plant, vehicles and facilities may be exposed during the construction of the Works should be identified and evaluated. Measures to reduce or control these risks or hazards should be defined during this assessment. The effectiveness of the measures defined and the baseline risk assessment prepared shall be monitored and reviewed from time to time to ensure that it remains relevant and accurate.

4.2.2 Issue based risk assessments

The Contractor will be required to carry out separate risk assessments during construction of the Works when methods and procedures are varied, for example when:

- Designs are amended,
- New machines are introduced,
- Plant is periodically cleaned and maintained,
- Plant is started-up or shut-down,
- Systems of work change or operations alter,
- Incidents or near-misses occur, or
- Technological developments invalidate prior risk assessments.

4.2.3 Continuous risk assessments

The Occupational Health and Safety Act specifically requires that employers shall provide and maintain working environments that are safe and without risk to health. The general awareness of hazards needs to be raised as work ethic to maintain a safe and risk free environment on an ongoing basis. This is achieved by continuous risk assessments, the most important form of risk assessment that takes place as an integral part of day-to-day management. Examples of continuous risk assessments include:

- Regular audits,
- Maintaining general hazard awareness,
- Pre-work risk assessment

4.3 Methodology for the preparation of risk assessments

The Contractor shall in the preparation of his risk assessments, follow the following general principles:

- Employ a team of suitably qualified individuals with appropriately varied and relevant experience in risk assessment,
- The appointed risk assessor shall lead the risk assessment,
- Provide the team with background data, scope of work, potential hazards and underlying causes, and
- Where necessary employ experts for complex risk assessments and aspects of risk assessments that require experiential judgment,
- Institute an ongoing system of identifying aspects of the work that require risk assessment, and
- Conduct risk assessments in workshops of the team or by individual members of the team under guidance of the leader as appropriate to the situation.

4.4 Elements of risk assessment

4.4.1 General

The process of carrying out a risk assessment consists of a number of well-defined steps. These steps improve decision-making by providing a greater understanding of the risks and their impacts. The main steps or elements of the risk assessment process are as follows:

- 1) Consider scope and nature of risks involved, determine purpose and physical and legal bounds of assessment and define risk evaluating criteria,
- 2) Systematically identify risks,
- 3) Analyze risks with regard to causes, likelihood of occurrence and possible consequences against the background of existing controls and its effectiveness,
- 4) Evaluate risks in terms of pre-established criteria to determine need and priority for attention,
- 5) Treat risks through a process of risk elimination, substitution, controlling risk at source, risk mitigation such as training and as far as risk remains, provide personal protective equipment (PPE),
- 6) Monitor and review progress and performance in terms of management system, and
- 7) Communicate and consult.

The following sections 4.4.2 to 4.4.7 deal with items (2) to (7) above. These items form the continuing process of the risk assessment as indicated in Figure 1, below.

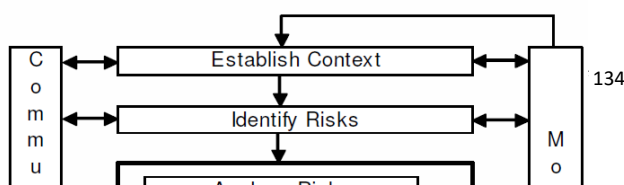

Figure 1: Risk Management Process

The Contractor shall ensure that the risk assessment compiled as part of his Health and Safety Plan contains at least these items.

4.4.2 Risk identification

The Contractor should regard this step of the risk assessment as the most important. Subsequent analysis and evaluation of risks and the development of risk control measures are wasted if the risks or hazards on the Works are not carefully identified.

The Contractor should bear the following principles in mind when identifying the risks:

- i) Systematically address all risks or hazards on the Works,
- ii) Review all aspects of the work, but consider only those that have a potential to cause harm,
- iii) Rank the risks identified in order of importance and then use appropriately advanced techniques to deal with major risks,
- iv) Deal mainly with major risks and don't obscure these with unimportant information, especially minor risks,
- iv) Address what actually happens in the workplace during the work activity
- v) Consider all persons that may be affected,
- vi) Highlight those groups and individuals who may particularly be at risk, and
- vii) Review the adequacy and effectiveness of existing safety controls and measures

4.4.3 Risk analysis

In this step, the Contractor will be required to analyze the risks identified by determining each risks frequency and magnitude or severity of the consequence of the risk or hazard. The frequency of occurrence of a hazard may be expressed as the number of times that it may occur in a year, decade, lifetime, century, or longer period, according to comparative human experience.

The magnitude of the likely consequence of a hazard may be expressed in terms of the degree of incapacitation, number of people or costs involved. The frequency of occurrence of a hazard and the magnitude of its consequence may be compounded as the risk that it poses as shown in the "risk matrix" in Figure 2 below.

Frequency of Occurrence of Hazard	Severity of Consequences of Potential Hazard					
	1 Medically treatable injury	1 Compensable injury	10 Compensable injuries	1 Permanently disabling injury	1 Fatality	10 Fatalities
Frequent; 1 or more occurrences per year	Medium	High	Very high	Severe	Severe	Severe
Several times during a career; 0.1 occurrences per year	Medium-low	Medium	High	Very high	Severe	Severe
Unlikely, but possible during a career; 0.01 occurrences per year	Low	Medium-low	Medium	High	Very high	Severe
Very unlikely during a career; 0.001 occurrences per year	Low	Low	Medium-low	Medium	High	Very high
Barely credible; 0.0001 occurrences per year	Low	Low	Low	Medium-low	Medium	High

Figure 2: Compounded Risk Matrix

The columns in the table represent the likely consequence of the hazard and the rows, the frequency of occurrence. The scales for both quantities represent consistent progressions, albeit they qualitative. The risks evidently range from low to severe. Note that diagonals in the matrix represent the risks of the identified hazards, taking the effectiveness of controls into consideration.

The table represents a typical risk matrix that need not necessarily be adopted by the Contractor. The Contractor may use an alternative risk matrix provided that it is approved as part of his Health and Safety Plan.

4.4.4 Risk evaluation

In this step the Contractor will be required to compare the assessed risk with similar risks previously experienced for the purpose of deciding how to treat the risk. A useful systematic approach for this purpose is as follows:

- If the assessed risk exceeds similar risks that have occurred in the past and that are considered to be unacceptable, the assessed risk would require treatment depending upon its magnitude as discussed in Section 4.4.5, or
- If the assessed risk exceeds similar historical risks that are acceptable, treatment of the assessed risk will depend on the extent by which it exceeds the historical risks, or
- If the assessed risk is less than historical risks that are unacceptable, treatment of the assessed risk will depend on the extent by which it is less than the historical risks, or
- If the assessed risk is less than historical risks that are acceptable, the assessed risk would also be acceptable and would not require any treatment.

4.4.5 Risk treatment

In this step, the Contractor will select and implement appropriate measures for dealing with risk. Typically measures comprise the following:

- Elimination by changing designs, procedures, management methods, etc., applicable to high

frequency–high consequence risks, or

- Reduction by changing designs, procedures, management methods, etc., applicable to high frequency–high consequence risks, or
- Minimization by changing designs, procedures, management methods, etc., applicable to high frequency–low consequence risks, or
- Transfer or share whole or part of the risk to another party by insurance, contractual arrangements or organizational structures, applicable to low frequency–high consequence risks, or
- Control to ensure that risks do not increase, applicable to low frequency–high consequence risks, or
- Retention together with provision of monitoring and personal protective equipment, applicable to low frequency–low consequence residual risks after reduction, or
- Acceptance without particular action other than provision of personal protective equipment, applicable to low frequency–low consequence risks.

The following principles enable the optimum treatment to be determined:

- Avoid risks altogether if possible by using different approaches, substances or methods of work,
- Combat risks at source rather than by adopting secondary measures,
- Adapt work to the individual rather than the individual to the work, that is, in the design consider the people and their attributes that will operate the system
- Take advantage of technological and technical progress,
- Risk prevention measures must be part of a coherent policy and approach to safety management that involves performance measurement, goal setting, feedback and analysis,
- Give preference to measures that protect the whole work force,
- Ensure that those for whom protection is provided understand what they need to do to make sure that the protection works, and
- Ensure that measures to control risks are an accepted part of an active health and safety culture supported by all levels of the organization; single risk reduction initiatives invariably fail.

4.4.6 Reporting and recording

The Contractor shall ensure that the risk assessment process is recorded in the form of a report and included in his Health and Safety Plan. The report should be easily accessible to the Contractor's employees, their representatives, to inspectors, the Employer or his Safety Agent and the Engineer. The essential contents of the report should be as follows:

- Objectives and expected outcomes,
- Description of the Works under assessment,
- Summary of context of study
- Composition of risk assessment team, (including qualifications and relevant experience),
- Approach used to systematically identify risks,
- Identified risks (ranked in order of priority),
- Method adopted for assessing frequencies and consequences of risks,
- Consequences (ranked in order of magnitude),
- Identification of individuals and groups who may be affected by major hazards and risk and who may especially be at risk,

- Basis for defining safety standards to be achieved,
- Contractor's resources devoted to risk assessment,
- Actions proposed to reduce unacceptably high risks,
- Review effectiveness of existing safety measures to control risks, and
- Implementation programme of selected treatments (including controls to manage unacceptably high risks).

4.4.7 Monitoring and review

It is necessary to monitor risks, the effectiveness of the risk treatment plan and the strategies and management system set up to control implementation. Control of the risk management program entails the setting of standards, monitoring actual performance, comparing the performance with the standards and correcting any deviations from the standard.

Risks and the effectiveness of the control measures need to be monitored to ensure changing circumstances do not alter risk priorities. Few risks remain static.

Ongoing review is essential to ensure that the management plan remains relevant. Factors that affect the likelihood and consequences of an outcome may change, as may factors that affect the suitability or cost of the various treatment options. If an accident occurs, or if more is learnt about the hazards in the workplace, the risk assessment may need to be reviewed or modified. Hazards may be observed that have not been anticipated or previously identified and which may require appropriate measures to be taken.

After an accident has occurred, it is important to determine whether it was predicted, whether preventive measures were identified, and if so, why they did not work, whether the risk assessment is still suitable and sufficient if it failed to predict the accident, whether the decision to accept a predicted risk as tolerable is still valid, why the accident occurred and what should be done to prevent similar accidents occurring again.

It is therefore necessary to regularly repeat the risk management cycle, the time between reviews being dependent on the nature of the risks and the degree of change likely to take place in the work activity. Review is an integral part of the risk management treatment plan.

4.4.8 Communication and consultation

The Contractor will be required to communicate and consult with internal and external stakeholders during each step of the risk assessment process. Stakeholders will include the Employer and his Safety Agent, the Engineer and the Contractor's employees and consultants.

Effective communication will ensure that those responsible for implementing the risk management process and those with a vested interest, understand the basis on which decisions are made and why particular actions are taken. It will also ensure that the perceptions of all those involved are noted and accommodated during the process.

5. RESOURCES

5.1 General

In this section of his Health and Safety Plan, the Contractor will be required to state how he intends to comply with the requirements of the Occupational Health and Safety Act, 1993 and all its Regulations and related incorporated standards with regards to the resources and facilities intended for use on the temporary and permanent Works.

5.2 Employees

5.2.1 Inspectors, supervisors and issuers

The Contractor shall provide in his Health and Safety Plan his intended Staffing Organogram for the Works. The organogram should include those inspectors, supervisors and issuers as envisaged in the Construction Regulations, 2003 required for the Works and any additional supervisory staff members as the Contractor (having taken the scope of the Works into account) considers necessary.

Copies of the supervisory staffs' curriculum vitae or portfolio of evidence and their appointment letters should be appended to the Contractor's Health and Safety Plan. The Contractor's Health and Safety Plan should in addition cover at least the following aspects:

- The number of unskilled, semi-skilled and skilled (including Foreman, Charge hands, Artisans, Operators, Drivers, Clerks, Storeman and Team Leaders) employees he intends employing on the Works,
- The health and safety training to be provided to the Contractor's employees,
- The programme of the health and safety training,
- Systems for the review of the effectiveness of the training provided, and
- Systems to determine further training requirements throughout the construction period.

In preparing his Health and Safety Plan, the Contractor shall ensure compliance with Clause PS 22 in Section 4.2 of the Project Specifications. Pro-forma letters of appointment for the various inspectors, supervisors and issuers as contemplated in the Construction Regulations, 2003 are included in Annexes to this specification for use by the Contractor. The Contractor shall ensure that he includes in his Health and Safety Plan the appointment letters for all his inspectors, supervisors and issuers appointed for the Works.

5.2.2 Subcontractors

The Contractor shall with reference to the use of subcontractors on the Works and without limiting his obligations, cover at least the following matters in his Health and Safety Plan:

- The steps intended to ensure that his Subcontractors prepare, implement and maintain Health and Safety Plans,
- How health and safety information will be made available to his Subcontractors when changes are brought about to the design,
- How he intends determining that his Subcontractors are registered and in good standing with the compensation fund or with a licensed compensation insurer prior to the commencement of the Works,
- How he intends determining if his Subcontractors have made provision in their tenders for the cost of health and safety measures during the construction of the Works,
- How he intends satisfying himself on the competencies and resources of Subcontractors he intends

appointing, and

- How he intends ensuring that his Subcontractors perform risk assessments prior to commencing their respective portions of the Works.

5.2.3 Competencies

The Contractor shall establish if a person is competent to perform a certain duty or be appointed in a certain capacity by requesting all candidates to supply the required certificates of competency. Where certificates of competencies cannot be delivered, the Contractor shall request a portfolio of evidence from the respective candidates. Contractors should do enquiries at the South African Qualifications Authority (SAQUA) relating to the qualifications required for appointment of competent persons.

5.2.4 Physical and psychological fitness

Were required by the Occupational Health & Safety Act and its regulations the contractor shall ensure that his employees are in possession of a valid medical certificate of fitness to work in such an environment.

In terms of the Construction Regulations 2003 medical certificates of fitness are required for persons working at elevated positions (Regulation 8(2)(b)), persons working on suspended platforms (Regulation 15(12)a) tower crane operators (Regulation 20 (g)) and construction vehicle and mobile plant operators (Regulation 21 (1)(d)(ii)).

5.3 Plant, vehicles and equipment

5.3.1 Suspended platform

The Contractor shall with reference to Regulation 15: Suspended platforms of the Construction Regulations, 2003, and without limiting his obligations, cover at least the following matters in his Health and Safety Plan:

- How he intends complying with SABS 1808 and SABS 1903,
- What systems he intends using to ensure the safety of all suspended platforms,
- What tests will be performed to establish the safety of suspended platforms,
- How he intends maintaining suspended platforms being used, and
- How he will document the design, testing, maintenance and inspections of the suspended platforms.

5.3.2 Boatswains chairs

The Contractor shall with reference to Regulation 16: Boatswains chairs of the Construction Regulations, 2003, and without limiting his obligations, cover at least the following matters in his Health and Safety Plan:

- Explain what systems he intends using to ensure the safety of all boatswains chairs,
- Explain how he intends maintaining boatswains chairs in use,
- What tests will be performed to establish the safety of boatswains chairs, and
- How he will document the design, testing, maintenance and inspections of the boatswains chairs.

5.3.3 Material host

The Contractor shall with reference to Regulation 17: Materials Hoist, of the Construction Regulations, 2003, and without limiting his obligations, cover at least the following matters in his Health and Safety Plan:

- How he intends confirming the construction stability of the material hoists,
 - What systems he intends using to ensure the safety of all material hoists,
 - What tests will be performed to establish the safety of all material hoists,
 - How he intends maintaining the material hoists being used, and
-
- How he will document the design, testing, maintenance and inspections of all material hoists and
 - What safety procedures and precautions are envisaged to ensure safe operation of the materials hoists.

5.3.4 Batch plants

The Contractor shall with reference to Regulation 18: Batch plants of the Construction Regulations, 2003, and without limiting his obligations, cover at least the following matters in his Health and Safety Plan:

- What systems he intends using to ensure the safety of all batch plants,
- How he intends maintaining the batch plants in use, and
- How he will document the design, testing, maintenance and inspections of batch plants in use.

5.3.5 Explosive powered tools

The Contractor shall with reference to Regulation 19: Explosive powered tools, of the Construction Regulations, 2003, and without limiting his obligations, cover at least the following matters in his Health and Safety Plan:

- How he intends controlling the issuing of explosive powered tools,
- How he intends implementing safety procedures prior to use of explosive powered tools, and
- What safety measures will be required during the use of explosive powered tools?

5.3.6 Cranes

This section of the specification shall be read in conjunction with the provisions of the Driven Machinery Regulations, 1988. The Contractor shall with reference to Regulation 20: Cranes, of the Construction Regulations, 2003 and without limiting his obligations, cover at least the following matters in his Health and Safety Plan:

- How will environmental factors be taken into account in respect to the use of cranes,
- What systems he intends using to ensure the safety of all cranes in use,
- How he intends maintaining cranes in use,
- What tests will be performed to establish the safety of all cranes in use,
- What safety procedures and precautions are envisaged to ensure the safe operation of all cranes in use,

- How he will document the design, testing, maintenance and inspections of all cranes in use, and
- The contractor shall proof compliance of the Driven Machinery Regulation, 1988, with reference to the lifting machinery and tackle being used.

5.3.7 Construction vehicles and mobile plant

The Contractor shall with reference to Regulation 21: Construction vehicles and mobile plant of the Construction Regulations, 2003, and without limiting his obligations, cover at least the following matters in his Health and Safety Plan:

- How he intends ensuring that construction vehicles and mobile plant are:
 - Of acceptable design and construction,
 - Maintained and in good working order,
 - Used according to design specifications, and
 - Are protected from falling into excavations, water or areas lower than the working surfaces,
- How he intends ensuring that workers are trained, authorised and physically fit to operate construction vehicles and mobile plant,
- What traffic arrangements and safety precautions will be implemented to ensure safe operation of construction vehicles and mobile plant on the Works, and
- How he intends safeguarding employees against construction vehicles and mobile plant moving on the construction site.

5.3.8 Electrical installation and machinery sites

This section of the specification shall be read in conjunction with the provisions contained in the Electrical Installation Regulations, 1992. The Contractor shall with reference to Regulation 22: Electrical Installation and machinery on construction sites of the Construction Regulations, 2003, and without limiting his obligations, cover at least the following matters in his Health and Safety Plan:

- How he intends safeguarding employees against electrical cables or apparatus under, over or on site, and
- How he will ensure that electrical installations are of adequate strength to withstand working conditions on a construction site.

5.3.9 Ladders

The Contractor shall with reference to Regulation 13A of the General Safety Regulations and without limiting his obligations, cover at least the following matters in his Health and Safety Plan:

- How he intends ensuring that ladders used are safe and constructed of materials approved for its intended use, and
- What precaution will be made to ensure the stability of ladders in use?

6. MATERIALS

6.1 General

In this section of his Health and Safety Plan, the Contractor will be required to state how he intends to

comply with the requirements of the Occupational Health and Safety Act, 1993 and all its regulations and related incorporated standards with regards to the design, supply, storage and erection of materials used for the temporary and permanent Works.

6.2 Fall protection equipment

The Contractor shall with reference to Regulation 8: Fall Protection Equipment of the Construction Regulations, 2003, and without limiting his obligations, cover at least the following matters in his Health and Safety Plan:

- Compilation of a fall protection plan,
- How the fall protection plan will be implemented and maintained,
- How employees will be screened and declared medically fit to work in areas where fall protection equipment is needed,
- How the safeguarding of persons, plant, vehicles, equipment and facilities on the construction site is contemplated,
- Training of staff working at heights and in the use of fall protection equipment,
- How a continuous assessment of the situation will be executed,
- How fall protection equipment will be inspected for safety, and
- How corrective actions will be implemented
- Emergency plans and procedures for treatment of incidents relating to falls from height.

6.3 Scaffolding

The Contractor shall with reference to Regulation 14: Scaffolding of the Construction Regulations, 2003, and without limiting his obligations, cover at least the following matters in his Health and Safety Plan:

- How compliance with SABS 085 will be ensured,
- How scaffolding in use will be maintained,
- What systems are intended to ensure the safety of scaffolding used, and
- What tests will be performed to establish the safety of scaffolding used
- Training plan for scaffold erectors and inspectors.

6.4 Use and temporary storage of flammable liquids on construction sites

This section of the specification shall be read in conjunction with the provisions for the use and storage of flammable goods as determined in the General Safety Regulations.

The Contractor shall with reference to Regulation 23: Use and temporary storage of flammable liquids on construction sites of the Construction Regulations, 2003, and without limiting his obligations, cover at least the following matters in his Health and Safety Plan:

- How flammable liquids will be stored to minimize the risk of fire or explosions,
- How the contractor will identify a flammable store
- What safety precautions will be employed if ventilation of the flammable store is not possible,
- How access to flammable stores will be controlled,
- How empty vessels used for the storage of flammable liquids will be disposed of,

- What quantity of flammable liquids will be stored on the construction site,
- What systems are intended to ensure the safe storage of flammable liquids, and
- What retaining methods will be used to prevent the spreading of any spillage.

6.5 Stacking and storage

This section of the specification shall be read in conjunction with the provisions for the stacking of articles contained in the General Safety Regulations.

The Contractor shall with reference to Regulation 26: Stacking and storage on construction sites of the Construction Regulations, 2003, and without limiting his obligations, cover at least the following matters in his Health and Safety Plan:

- Who will supervise the stacking and storage of materials on site, and
- What systems are intended to ensure the safe stacking and storage of materials on the site

6.6 Personal safety equipment and facilities

The Contractor shall comply with Section 2 of the General Safety Regulations, and shall in particular provide all necessary personnel protective equipment for his personnel for the duration of the construction period. To this end the Contractor shall without limiting his obligations indicate in his Health and Safety Plan:

- Identify training requirements in the Contractors Training plan in the use and maintenance of personal protective equipment,
- The type of personnel safety equipment he will provide,
- How he intends issuing it to his employees, and
- How he will maintain the personnel safety equipment issued.

6.7 First aid, emergency equipment and procedures

The Contractor shall comply with Section 3 of the General Safety Regulations regarding first aid, emergency equipment and procedures.

7. CATEGORIES OF WORK

In this section of his Health and Safety Plan, the Contractor will be required to state how he intends to comply with the requirements of the Occupational Health and Safety Act, 1993 and all its regulations and related incorporated standards with regards to the execution of the following categories of work.

7.1 General

The Contractor shall, without limiting his obligations, cover at least the following matters in his Health and Safety Plan under this category of work:

7.1.1 Construction welfare facilities

Contractors will be required to adhere to Regulation 28: Construction welfare facilities of the Construction Regulations, 2003. This regulation must be read in conjunction with the provisions of the Facilities Regulations, 1990 (as amended) and SANS 0400.

The Contractor must discuss the following in detail in his safety plan:

- How will the Contractor establish the amount of facilities required for employees to shower, change, eat and attend to sanitary needs
- What measures will the employer take to house employees on site who lives far from their residences or for the provision of transport

7.1.2 Environmental regulations for workplaces

The Contractor shall comply with the Environmental Regulations for Workplaces, 1987, and shall address the following aspects as described in the regulations in his Health and Safety plan:

- Thermal requirements,
- Lighting,
- Windows,
- Ventilation,
- Housekeeping,
- Noise and hearing conservation,
- Precautions against flooding, and
- Fire precautions and means of egress.

7.1.3 Housekeeping on construction sites

Contractors will be required to adhere to Construction Regulation 25: Housekeeping on construction sites, of the Construction Regulations, 2003. This regulation must be read in conjunction with the provisions of the Environmental Regulations for Workplaces, 1987 (as amended). The Contractor must discuss the following in detail in his safety plan:

- How will contractors ensure the neatness of construction sites
- What measures does the Contractor envisage to?
 - Store and/or stack materials,
 - Remove debris from site,
 - Prevent unauthorized entrance to the site
 - Protect employees or passers-by from falling objects

7.1.4 Fire precaution on construction sites

Contractors will be required to adhere to Construction Regulation 27: Fire precautions on construction sites, of the Construction Regulations, 2003. This regulation must be read in conjunction with the provisions of the Environmental Regulations for Workplaces, 1987 (as amended).

The Contractor must discuss the following in detail in his safety plan:

- How the Contractor will minimize the risk of fire on the site
- How the Contractor will identify potential fire hazards
- What prohibitions the Contractor will implement to manage risk areas
- How many employees the Contractor will train in fire fighting
- What organization the Contractor envisage to combat fires on sites
- What precautions and procedures will be followed to evacuate employees in the case of a fire

7.1.5 Water environments

The Contractor will be required to adhere to Construction Regulation 24: Water Environments, of the Construction Regulations, 2003.

The Contractor must discuss the following in detail in his safety plan:

- What precautions will the Contractor take to identify dangers where employees may fall into water
- What safety procedures and equipment will the Contractor implement to safeguard employees working at water environments

7.1.6 Structures

The Contractor will be required to adhere to Construction Regulation 9: Structures, of the Construction Regulations, 2003. The Contractor must discuss the following in detail in his safety plan:

- Explain what controls, test or precautions will be made to prevent structures from collapsing during construction,
- The Contractor shall indicate what steps will be taken and implemented to ensure that structures or parts thereof will not be loaded in such a manner that it may collapse, and
- What procedures does the Contractor envisage to implement in order to obtain all relevant data on structures before commencement of construction work?

7.1.7 Watching, barricading and lighting

The Contractor will be required to adhere to regulations 11.3. (i) and 11.3.(l) of the Construction Regulations, 2003. The Contractor must discuss the following in detail in his safety plan in respect of any excavation or other dangerous activity adjacent to public roads and thoroughfares:

- Type of barrier or fencing to be used,
- Type and spacing of warning lights and warning signs, and
- Control systems and personnel he intends employing to ensure that the above items are maintained.

7.1.8 Hazardous chemical substances

The Contractor will be required to adhere to the Regulations for Hazardous Chemical Substances 1995 as amended in the handling and storage cement of and other hazardous chemical substances. The Contractor must discuss the following in detail in his safety plan in respect of each hazardous chemical substance that will be used in the works:

- Storage of substance
- Handling of substance
- Protective clothing and other devices to be used while handling the substance
- Medical surveillance.

7.2 Site clearance

The Contractor shall, without limiting his obligations, cover at least the following matters in his Health and Safety Plan under this category of work:

7.2.1 Demolition work

Contractors will be required to adhere to Construction Regulation 12: Demolition work, of the Construction Regulations, 2003.

The Contractor shall discuss the following in detail in his safety plan:

- Briefly explain how he will safeguard people and property during and after demolition works
- Briefly explain how he will protect staff from dangerous situations
- Discuss the methods proposed to safeguard the public and property against harm during demolition works
- Discuss what type of equipment he envisage to use during demolition work
- How will the Contractor ensure the safety of equipment used during demolition work
- What steps will the Contractor deem necessary to take where hazardous materials is encountered
- Dust control measures
- Noise control measures

7.3 Earthworks

Contractors will be required to adhere to Construction Regulation 11: Excavation work, of the Construction Regulations, 2003. The Contractor must discuss the following in detail in his safety plan:

- How will the Contractor establish the stability of ground prior to excavations,
- What steps will the Contractor follow to ensure that bolstering, shoring and bracing is sufficient to ensure the safety of the excavation, and
- What steps will the Contractor follow to ensure the equipment used to safeguard an excavation is sufficient and safe

7.4 Concrete

The Contractor shall, without limiting his obligations, cover at least the following matters in his Health and Safety Plan under this category of work:

7.4.1 Formwork and support work

The Contractor shall with reference to Regulation 10: Formwork and support work, of the Construction Regulations, 2003, and without limiting his obligations, cover at least the following matters in his Health and Safety Plan:

- How the design of formwork and support work will be carried out,
- How the erection of formwork and support work will be managed,
- How the continuous assessment of the safety of formwork will be done,
- How the loading of formwork and support work will be managed or limited, and
- How he intends keeping records of the above.

7.5 Pipes

The Contractor shall comply with Section 9 of the General Safety Regulations, with regards to the welding, flame cutting, grinding, soldering or similar operations associated with pipe work.

8. IMPLEMENTATION OF CONTRACTOR'S HEALTH AND SAFETY PLAN

8.1 General

The Contractor shall describe in his Health and Safety Plan how he intends implementing his plan. The Contractor shall indicate the methods he intends using to ensure accurate record keeping of all critical elements identified in his risk assessment and covered in his Health and Safety Plan. The Contractor shall indicate how internal audits will be carried out, how shortcomings will be addressed, how he intends to review the safety plans, how he would train staff and how he would implement the findings and recommendations of internal audits or inputs of employees.

8.2 Administrative systems

The Contractor shall comply with Section 9 of the General Administrative Regulations, 1996. The Contractor's administrative system shall without limiting his obligations, cover the following:

- Up keep of a safety file on site,
- Maintenance of his Health and Safety plan,
- Procedures to follow for the appointment of competent persons,
- Application for permits,
- Procedures to follow for notifications,
- Injury on duty [IOD] administration,
- Recording of minutes of safety meetings,
- Recording of checklists,
- Safe keeping of checklists, and
- Internal audits.

The Contractor shall in particular ensure that at least one copy of the Occupational Health and Safety Act, 1993 and its Regulations is available on the for every 20 employees employed

8.3 Reporting systems

The Contractor shall comply with Section 9 of the General Administrative Regulations, 1996 and shall in particular (in accordance with section 12) furnish an inspector with information relating to health and safety on the construction site, when requested to do so.

The Contractor shall notify the Employer of any investigations, complaint or criminal charge which may arise as a consequence of the provision of the Occupational Health and Safety Act, 1993 and its Regulations, pursuant to work performed in terms of this Contract.

8.4 Training

The Contractor shall train all his employees in accordance with the requirements of section 13 of the Occupational Health and Safety Act, 1993. The Contractor shall ensure that every employee is informed of the following:

- The hazards of any work he has to perform or plant machinery or equipment he is permitted to use, and
- The precautionary measures which should be taken regarding the above.

The Contractor shall, without limiting his obligations, indicate in his Health and Safety Plan how he intends:

- Identifying the training needs of the personnel he intends employing, and

- Implementing the training identified
- What proof of induction training will be carried by his employees (e.g. laminated type identification card).

8.5 Safety meetings

The Contractor shall conduct at least one formal safety meeting per month with his employees to ensure safety awareness and shall maintain appropriate records of attendance and meeting content. Such records shall be made available to the Employers Safety Agent. Such meetings shall address at least the following:

- Accident / safety incidents
- Hazardous conditions
- Hazardous materials / substances
- Job or work projections
- Work procedures
- Protective clothing / equipment
- Housekeeping
- General safety topics

8.6 Inspections and monitoring

The Contractor shall be required to inspect each workplace prior to works commencing to ensure that all protective equipment is in place and that by entering the workplace no person will be exposed to any hazard which could affect his health or safety. The Contractor shall without limiting his obligations, indicate the following in his Health and Safety Plan:

- The inspection and monitoring procedures he intends employing to determine the safety of workplaces, and
- Who will be responsible for the checking of each workplace at the commencement of each shift.

The Contractor shall include in his Health and safety Plan all the checklists he intends using during the inspection and monitoring of the implementation of his Health and Safety Plan. The Contractor can expect inspections of the works by any of the following parties:

- The Employer or his Safety Agent,
- The Employer's Occupational Safety Officer, or
- The designated officer serving in the Department of Manpower and appointed by the Minister as Chief Inspector or his representative.

In addition to site inspections performed by the Employer or his safety agent they shall also do audits and assess the safety situation at the works and investigate incidents. Follow-up inspections will be performed to ensure compliance to recommendations done. The Employer, his Safety Agent or his Occupational Safety Officer may stop the work at any time under the following conditions:

- If the Contractor is not compliant with his Health and Safety Plan
- Imminent threat to the health and safety of any person on site
- Continuous non-conformance to corrective action requests.

Inspections by the Chief Inspector or his representative will be by appointment and the purpose would be to investigate complaints received by the Inspector or to investigate serious incidents. The Chief Inspector or his representative may issue prohibition notices to stop the activities at the works until the situation investigated has been resolved or he may issue an improvement notice whereby the Contractor will have a period to rectify any hazard identified by the inspector.

9. AUDITING

9.1 Internal audits

The audits contemplated in regulation 4.(1)(d) of the Construction Regulations, 2003 will be carried out by the Employer or his appointed Safety Agent. The intervals for the audits shall be agreed between the Contractor and the Employer or his Safety Agent during the preparation of the Contractor's Health and Safety Plan, but shall be carried out at least once every month or at such shorter interval that an inspector may require.

The Employer or his Safety Agent shall provide at least 7 calendar days' notice prior to the conducting of an audit. The findings of each audit will be made known to the Contractor and the Employer in a report prepared by the Employer or his Safety Agent and will be submitted to all parties within seven working days of the respective audit being completed.

Any shortfalls identified will be documented in the audit report together with the Contractor's proposals to rectify the same. All audit reports will be filed in the Health and Safety File. A date for a follow up audit will be negotiated with the Contractor to verify the implementation of all actions to rectify shortfalls as identified in the audit report.

The Contractor will ensure that the same arrangement detailed above be implemented with his Contractors to ensure his compliance with the Construction Regulations and contemplated in regulation 5. (3)(c). The audits described above only constitute part compliance by the Employer or the Safety Agent with regulation 4. (1)(c) of the Construction Regulations, 2003.

9.2 External audits

The Engineer or the Employer may obtain the services of an external auditor to carry out additional audits or follow-up audits, as the case may be, at any time during the construction period provided that:

- i) The audit or follow-up audit are carried out during ordinary working hours, and
- ii) The Contractor is given at least 24 hours' notice of the intention to carry out such audits.

The Contractor's employees indicated in Section 9.1 will be present during any audit carried out by the Employer or his Safety Agent.

10. MEASUREMENT AND PAYMENT

10.1 Measurement and payment

The scheduled items for health and safety will be as specified in the Schedule of Quantities. The Contractor shall price all items scheduled in this section of the schedule of quantities. Failure by the Contractor to price these items may force the Employer to reject the Contractor's tender in terms of

clause 4.(4) of the Construction Regulations, 2003.

11. ANNEXURES

11.1 APPOINTMENT LETTERS

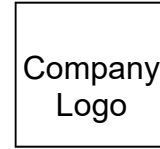

Company Name
Company Address
Code

Attention: (Assistant Construction Supervisor's Name)

APPOINTMENT OF THE ASSISTANT CONSTRUCTION SUPERVISOR IN TERMS OF CONSTRUCTION REGULATION 6(2)

I, (contractor's name) hereby appoint (assistant construction supervisor's name) as the assistant supervisor responsible for (site address) to carry out the construction work of (description of construction work and area of responsibility).

In terms of this appointment, you are required to ensure that all construction work performed under your supervision is carried out as follows:

1. By persons suitably trained and competent to do such work;
2. That all persons are aware and understand the hazards attached to the work being carried out;
3. That the required risk assessments are carried out;
4. That precautionary measures are identified and implemented;
5. That discipline is enforced at the construction site at all times;
6. That all identified statutory requirements are met; and
7. That any other interest in terms of health and safety with respect to the responsible area is met.
8. You will accept the duties of the Construction Supervisor in his absence.

You are required to report any deviations of the above-mentioned instruction to (construction supervisor's name) and in his absence to the contractor's representative. This appointment is valid from (date) to the completion of the stipulated construction work.

You shall submit a written weekly report any non-compliance with the construction Regulations, 2003.

_____	_____	_____
Contractor's representative	Signature	Date
Full name		

Kindly confirm your acceptance of this appointment by completing the following:

I, (assistant construction supervisor) understand the implications of the appointment as detailed above and confirm my acceptance.

_____	_____	_____
Assistant construction supervisor's full	Signature	Date
name		



Company Name
Company Address
Code

Attention: (Safety Officer's Name)

APPOINTMENT OF THE CONSTRUCTION HEALTH AND SAFETY OFFICER IN TERMS OF CONSTRUCTION REGULATION 6(6)

I, (contractor's name) hereby appoint (safety officer's name) as the Construction Health and Safety Officer responsible for (site address) to manage all the health and safety issues as required in terms of the Act by establishing a health and safety program with elected health and safety Representatives.

You shall ensure that all the requirements in terms of the Act and in particular in terms of the Construction Regulations, 2003 are met. You shall also ensure that all appointed subcontractors comply with the requirements as stipulated in the Construction Regulations, 2003.

You shall further ensure that all records, registers and required lists are maintained and shall stop construction work upon identifying any non-compliance by any contractor; this includes stopping any work should the competency of the person carrying out such work be questionable.

This appointment is valid from (date) to the completion of the stipulated construction work.

Contractor's representative Signature Date
Full name

Kindly confirm your acceptance of this appointment by completing the following:

I, (construction health and safety officer's name) understand the implications of the appointment as detailed above and confirm my acceptance.

Construction Health & Safety Signature Date
Officer's full name



Company Name
Company Address
Code

Attention: (Construction Vehicle and Mobile Plant Inspector)

APPOINTMENT OF THE CONSTRUCTION VEHICLE AND MOBILE PLANT INSPECTOR IN TERMS OF CONSTRUCTION REGULATION 21(1)(j)

I, (contractor's name) hereby appoint (construction vehicles and mobile plant inspector's name) as the construction vehicles and mobile plant inspector responsible for (site address) to inspect on a daily basis all construction vehicles and mobile plant, as per the provided checklist.

You shall ensure that when becoming aware of any health and safety hazards in respect to construction vehicles and mobile plant that these hazards are reported in writing to the Construction Health and Safety Officer and Construction supervisor and the necessary precautionary measures are taken and enforced.

You shall further ensure that the requirements of the Construction Regulations, 2003 are at all times met. This appointment is valid from (date) to the completion of the stipulated construction work.

Contractor's representative Signature Date
Full name

Kindly confirm your acceptance of this appointment by completing the following:

I, (construction vehicles and mobile plant inspector's full name) understand the implications of the appointment as detailed above and confirm my acceptance.

Construction vehicles and mobile Signature Date
plant inspector's full name



Company Name
Company Address
Code

Attention: (SubContractor's Name)

APPOINTMENT OF SUBCONTRACTOR IN TERMS OF THE CONSTRUCTION REGULATION 5(3)(b)

I, (contractor's name) hereby appoint (subcontractor's name) as the subcontractor responsible for (site address) to carry out the construction work of (description of construction work).

You shall ensure that you meet all the requirements in terms of the Act and in particular in terms of the section 37(2) agreement and the Construction Regulations, 2003. You shall also ensure that all contractors appointed by yourself and reporting to you comply with the requirements as stipulated in the Construction Regulations, 2003.

You shall also ensure that all the information and specifications to ensure that the construction work is carried out in a safe manner are carried over to all contractors appointed and reporting to you.

You shall further ensure that all records, registers and required lists are maintained and that all persons appointed to carry out tasks as stipulated by these regulations are competent and have the necessary resources to complete their tasks effectively in such a manner that health and safety is not in any manner compromised.

This appointment is valid from (date) to the completion of the stipulated construction work.

You shall submit a written weekly report on all shortfalls that have not been met in terms of these regulations.

Contractor's representative full Signature Date
name

Kindly confirm your acceptance of this appointment by completing the following:

I, (subcontractor's name) understand the implications of the appointment as detailed above and confirm my acceptance.

Subcontractor's Representative full Signature Date
name



Company Name
Company Address
Code

Attention: (Construction Supervisor's Name)

APPOINTMENT OF THE CONSTRUCTION SUPERVISOR IN TERMS OF CONSTRUCTION REGULATION 6(1)

I, (contractor's name) hereby appoint (construction supervisor's name) as the Supervisor responsible for (site address) to carry out the construction work of (description of construction work and area of responsibility).

In terms of this appointment, you are required to ensure that all construction work performed under your supervision is carried out as follows:

1. By persons suitably trained and competent to do such work;
2. That all statutory appointments have been completed;
3. That, where required, health and safety committees are established and that meetings are accordingly held;
4. That all persons are aware and understand the hazards attached to the work being carried out;
5. That the required risk assessments are carried out;
6. That precautionary measures are identified and implemented;
7. That discipline is enforced at the construction site at all times;
8. That all identified statutory requirements are met; and
9. That any other interests in terms of health and safety with respect to the responsible area is met.
10. You will in writing delegate your duties to the Assistant Construction Supervisor while absent from site.

You are required to report any deviations of the above-mentioned instructions to (contractor's name). This appointment is valid from (date) to the completion of the stipulated construction work. You shall submit a written weekly report on all shortfalls that have not been met in terms of these regulations

Contractor's representative full name Signature Date

Kindly confirm your acceptance of this appointment by completing the following:

I, (construction supervisor) understand the implications of the appointment as detailed above and confirm my acceptance.

Construction Supervisor's full name Signature Date



Company Name
Company Address
Code

Attention: (Form work and Support work supervisor's name)

APPOINTMENT OF THE FORMWORK AND SUPPORT WORK SUPERVISOR IN TERMS OF CONSTRUCTION
REGULATION 10(a)

I, (contractor name) hereby appoint (form work and support work supervisor's name) as the formwork and support work supervisor responsible for (site address) to supervise and carry out all the necessary inspections in terms of all formwork and support work as per the provided checklist.

You shall ensure that when becoming aware of any health and safety hazards in respect to formwork and support work that the necessary precautionary measures are taken and enforced. Hazards are reported in writing to the Construction, Health and Safety Officer and the Construction Supervisor.

You shall further ensure that the requirements of the Construction Regulations are at all times met. This appointment is valid from (date) to the completion of the stipulated construction work.

Contractor's representative full Signature Date
name

Kindly confirm your acceptance of this appointment by completing the following:

I, (formwork and support work supervisor's full name) understand the implications of the appointment as detailed above and confirm my acceptance.

Formwork and Support Work Signature Date
Supervisor's full name



Company Name
Company Address
Code

Attention: (Ladder Inspector's Name)

APPOINTMENT OF THE LADDER INSPECTOR IN TERMS OF CONSTRUCTION REGULATION 13(A)

I, (contractor's name) hereby appoint (ladder inspector's name) as the ladder inspector responsible for (site address) to manage ladders on site. You should inspect the ladders as per the checklist at least once a week.

You shall ensure that when becoming aware of any health and safety hazards in respect to ladders that these hazards are reported in writing to the Construction Health and Safety Officer and Construction supervisor and the necessary precautionary measures are taken and enforced.

You shall further ensure that the requirements of the Construction Regulations, 2003 are at all times met. This appointment is valid from (date) to the completion of the stipulated construction work.

Contractor's representative full name Signature Date

Kindly confirm your acceptance of this appointment by completing the following:

I, (ladder inspector's full name) understand the implications of the appointment as detailed above and confirm my acceptance.

Ladder inspector's full name Signature Date



Company Name
Company Address
Code

Attention: (Risk Assessor's Name)

APPOINTMENT OF THE CONSTRUCTION SITE RISK ASSESSOR IN TERMS OF CONSTRUCTION REGULATION 7(1)

I, (contractor's name) hereby appoint (risk assessor's name) as the construction site risk assessor responsible for (site address) to carry out risk assessments prior to the commencement of construction work and any other risk assessment that may be required for the duration of the construction work.

You shall ensure that all risks are identified and analyzed and that safe working procedures are drafted and implemented to reduce, mitigate or controls the hazards that were identified.

You will at least use the risk evaluation program with the provided checklists.

This appointment is valid from (date) to the completion of the stipulated construction work.

Contractor's representative full name Signature Date

Kindly confirm your acceptance of this appointment by completing the following:

I, (construction site risk assessor's name) understand the implications of the appointment as detailed above and confirm my acceptance.

Construction site Risk Assessor's full name Signature Date



Company Name
Company Address
Code

Attention: (Scaffolding Supervisor's Name)

APPOINTMENT OF THE SCAFFOLDING SUPERVISOR IN TERMS OF CONSTRUCTION REGULATION 14(2)

I, (contractor's name) hereby appoint (scaffolding supervisor's name) as the scaffolding supervisor responsible for (site address) to supervise and carry out all the necessary inspections in terms of all scaffolding work. (Whether newly erected, altered or moved as per the provided checklist)

You shall ensure that when becoming aware of any health and safety hazards in respect to scaffolding work that these hazards are reported in writing to the Construction Health and Safety Officer and Construction supervisor and the necessary precautionary measures are taken and enforced.

You shall further ensure that the requirements of the Construction Regulations, 2003 are at all times met. This appointment is valid from (date) to the completion of the stipulated construction work.

Contractor's representative full name Signature Date

Kindly confirm your acceptance of this appointment by completing the following:

I, (scaffolding supervisor's full name) understand the implications of the appointment as detailed above and confirm my acceptance.

Scaffolding Supervisor's full name Signature Date

11.2 NOTIFICATION TEMPLATES



Company Name
Company Address
Code

Attention: The Provincial Director
The Department of Labour [Postal Address*]

NOTIFICATION OF CONSTRUCTION WORK ON CONTRACT [NUMBER] [CONTRACT DESCRIPTION]

In terms of regulation 3.(1) of the Construction Regulations , 2003 promulgated on 18 July 2003 in terms of the Occupational Health and Safety Act, 1993 (Act 85 of 1993), we hereby notify you of our intention to commence construction works on the abovementioned contract, which:

Includes the demolition of a structure exceeding a height of 3 meters, Includes the use of explosives to perform the construction work, Includes the dismantling of fixed plant at a height greater than 3 meters, Will exceed 30 days or will involve more than 300 person days of construction, Includes excavation work deeper than 1 meter, or
Includes working at a height greater than 3 meters above ground or a landing.

1. Parties involved on the Contract

1.1 The Principal Contractor is: [Contractor's Name] [Contractor's postal address]
[Contractor's postal address]
Att: [Contractor's contact person and telephone number]

1.2 The Client (Employer) is: [Employer's Name]
[Employer's postal address]
Att: [Employer's contact person and telephone number]

1.3 The Client's Safety Agent is: [Safety Agent's Name]
[Safety Agent's postal address]
Att: [Safety Agent's contact person and telephone number]

1.4 The Contractor's Construction Supervisor is: [Contractor's Construction Supervisor's name and telephone number]

2. Details of the construction works

2.1 The physical address of the works is: [Physical address of works]
[Physical address of works]

The nature of the construction works is: [Provide a description of the works].

The expected commencement date of the Works is: [Insert expected commencement date]

The expected completion date of the works is : [Insert expected completion date]

The estimated maximum number of persons on the construction site:

A total of _____ contractors will be accountable to the Principal Contractor on the construction site during the execution of the Works. The names of the contractors already chosen are as follows: [Provide a list of the Contractor's subcontractors already appointed]

3. Other details

The Principal Contractor's compensation registration number is: _____

In terms of regulation 3.(3) a copy of this notification will be kept on site for inspection. We trust the above is in order.

Yours faithfully,

Signature

Date

* Postal Address of Provincial Director as indicated in regulation 1 of the General Administrative Regulations, 1996.

11.3 IDENTIFIED HEALTH AND SAFETY HAZARDS

In terms of Regulation 4(1)(b) of the Construction Regulations 2003 the following hazards anticipated with the scope of work have been identified.

NOTE: The list of potential hazards is by no means intended to be all inclusive and is not limited to this list, and it remains the responsibility of the Contractor to identify all possible hazards with regards to his scope of work and to put measures in place to mitigate, reduce or control these hazards.

- Potential Hazards
- Commissioning of new installations Confined space entry
- Demolition/breaking into existing structures Excavation shoring / brazing
- Excavations been flooded during rainy season Explosives
- Hazardous material handling / storage / management Heat stress
- Loading and off-loading vehicles Manual handling of materials Plant and equipment integrity Public and traffic safety Requirements for plant isolations Roofing and Cladding operations
- Safe usage and storage of Oxygen, Acetylene and LPG cylinders Scaffolding
- Stacking and storage of equipment / materials Tie-ins into existing equipment
- Usage of compressed air and equipment Work involving radio-active sources Working in operational areas
- Working on live electrical installations / sub-stations / MCC rooms Working on moving equipment.

PART C4: SITE INFORMATION

TABLE OF CONTENTS

C4.1	Locality Plan
C4.2	Physiography

C4.2 PHYSIOGRAPHY

C.4.2.1 TOPOGRAPHY

The BRT Line 3 Section 1 traverses a flat to rolling terrain. The average elevation is 1321 m, the maximum 1353 m and the minimum is 1302 m above mean sea level. The route follows a westerly direction from Pretoria CBD.

C4.2.2 CLIMATE

The study area is situated in the moderate eastern plateau area of South Africa (refer **Figure 0-**). Climate data from Pretoria was used for the purposes of this analysis.

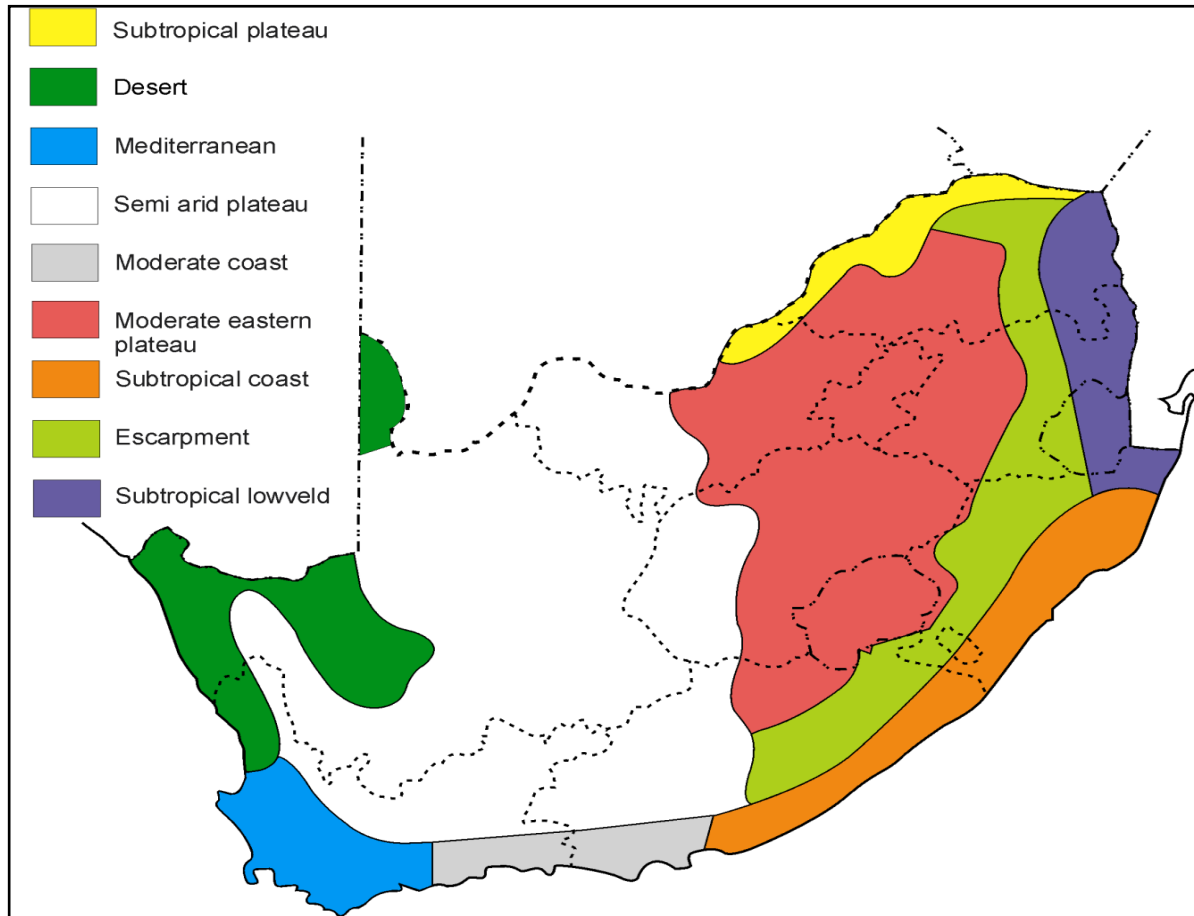
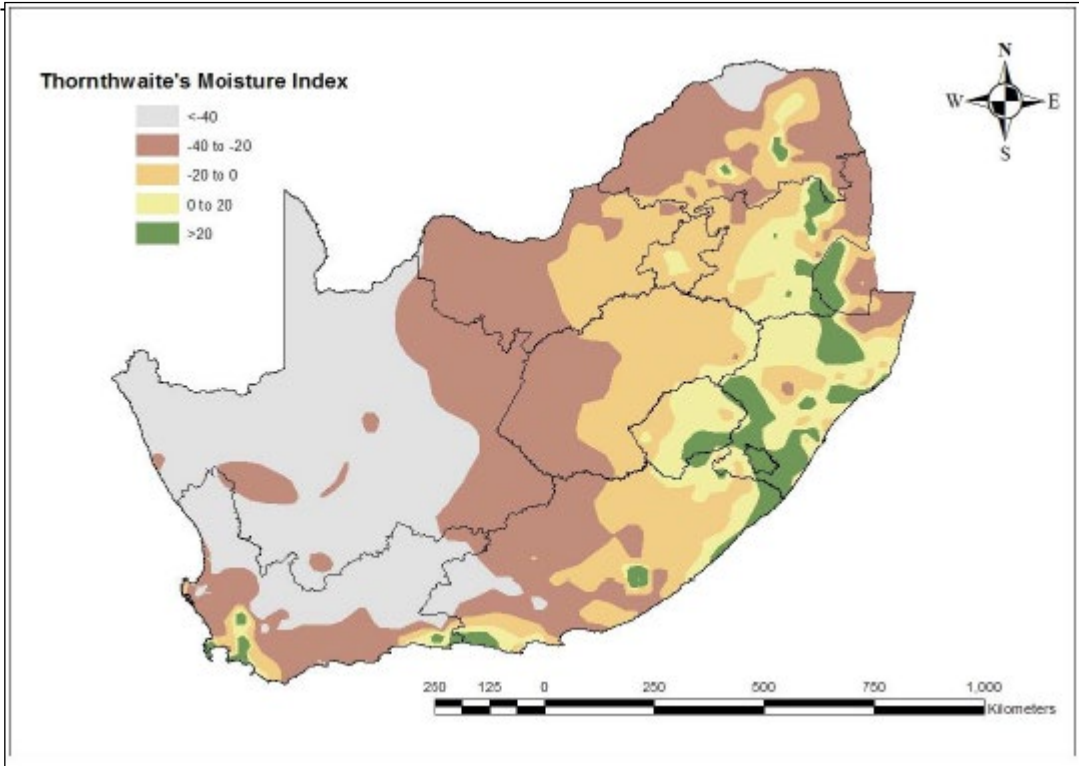

Figure 0-2: Climate Zones of South Africa.

The Thornthwaite's Moisture Index is a function of evapo-transpirations i.e. dependent on vegetation and rainfall. As indicated below, the road is located in an area where the Thornthwaite's Moisture index is between -20 and 0. The road is therefore in a wet region. The rainfall station located in the vicinity of the project is the Pretoria University Proefplaas – 0513435A4 '(-25.7520 28.2580 138 m 2018)

The South African Weather Service (SAWS) was contacted in order to obtain the rainfall and temperature data for the Pretoria University Proefplaas. The weather station is located approximately 9.2km East of the project area – The temperatures and rainfall information obtained is based data collected over 5 years – period 2018 to 2022.



C4.2.2.1 Precipitation

The average annual amount of precipitation in Pretoria CBD is 855.6mm. The month with the highest precipitation on average is November with 152.8mm of precipitation. The months with the least precipitation on average is July and August with an average of 0.4 mm.

There is an average of 95.8 days of precipitation, with the most precipitation occurring in November with 17.0 days and the least precipitation occurring in July and August with 0.6 and 1.0 days respectively.

The area is classified as wet under Macroclimatic regions of Southern Africa and it has a Weinert N that is greater than 5 as denoted in TRH4 1996. The rainfall statistics obtained from SAWS suggests that this area might be moderate rather than wet and for design and construction purposes we will classify it as moderate.

Roads get affected by the rain in various ways, rainfall is one of the key components of climate that causes the road to fail. The weathering pattern of road materials is taken into consideration when designing new pavements. Drainage is also another key aspect that is taken into consideration when designing new roads as it affects the safety of drivers and lifespan of the road. From this perspective, it is critical that rainfall statistic of the area where the road will be built is known and is analysed thoroughly.

RAINFALL ANALYSIS FOR: PRETORIA UNIVERSITY PROEFPLAAS : PERIOD 2018 to 2022

Date: 2023/04/20

Data for the Average Calculation is not used if:
 There are more than five consecutive days of accumulation
 The data for certain days in the month is not available
 The accumulation period occurred at the end of the month

Data for the Frequency calculation is not used if:
 The data for certain days in the month is not available
 The accumulation period occurred at the end of the month

Month	Average Monthly Rainfall (mm)	Standard Deviation	Average Number of Rain Days per Month	Number of Months	Average number of days of Rain						Maximum 24-hour Rainfall (mm)	Date of Maximum 24-hour Rainfall
					1 - 5 mm	5.1 - 10mm	10.1 - 20mm	20.1 - 50mm	50.1 - 100 mm	> 100 mm		
JAN	146.2	53.8	14.7	3.0	3.3	2.3	2.0	1.7	0.7	0.0	85.4	2021/01/10
FEB	112.9	18.6	15.0	3.0	6.3	2.0	2.0	0.7	0.3	0.0	82.4	2022/02/04
MAR	120.0	68.8	10.8	4.0	2.8	1.0	2.5	0.8	0.3	0.3	132.4	2018/03/22
APR	98.1	41.6	9.8	5.0	2.0	1.2	1.6	1.2	0.4	0.0	76.0	2018/04/11
MAY	6.6	7.3	2.3	3.0	1.0	0.0	0.3	0.0	0.0	0.0	15.0	2022/05/20
JUN	5.6	8.9	1.3	4.0	0.5	0.0	0.3	0.0	0.0	0.0	18.0	2022/06/24
JUL	0.4	0.4	0.6	5.0	0.0	0.0	0.0	0.0	0.0	0.0	0.8	2018/07/10
AUG	0.4	0.4	1.0	2.0	0.0	0.0	0.0	0.0	0.0	0.0	0.6	2018/08/24
SEP	18.4	20.3	3.3	4.0	0.8	0.5	0.3	0.3	0.0	0.0	36.0	2021/09/30
OCT	67.4	15.8	9.0	2.0	2.5	1.0	1.5	1.0	0.0	0.0	52.0	2018/10/13
NOV	158.2	0.0	17.0	1.0	3.0	3.0	7.0	1.0	0.0	0.0	62.0	2020/11/20
DEC	121.4	0.0	11.0	1.0	3.0	2.0	2.0	2.0	0.0	0.0	96.8	2019/12/09
YR	855.6		8.0	37	25	13	20	9	2	0		

Figure 1.2.1–Rainfall Data

January, February, March, November and December are the wettest months of the year in Pretoria area and April is not far behind as shown above.

C4.2.3 Temperature

Southern Africa has been divided into three climatic regions as shown on TRH4 1996 edition, the greater North West region under which the road is situated falls under dry climate region with a Weinert N value greater than 5. The other method of delineating climate regions is that of Thornthwaite Moisture Index (TMI), it takes into consideration evapotranspiration (i.e. rainfall & vegetation), soil water storage, moisture deficit and run off. The TMI for the North West region can be described as ranging between – 40 and – 20, this means this area is classified as a wet region.

The warmest month, on average, is January with an average maximum temperature of 35.7 °C. This area generally has cold winter and warm summer as per the data obtained from South African Weather Services (SAWS). Winter commences in May and runs up to August. The rainy season begins in October and runs up to April and the months with most rain are January, February, November and December.

From a road perspective, the temperature plays a key part with regard to decisions taken to cater for design, construction and post construction stages. Typical example of these decisions is to determine when the temperature is going to be cold or warm in order to determine the type of pavement to be built in that particular area and to plan for the construction techniques feasible for the predetermined temperatures. Further to the above example, there are certain construction activities like laying of asphalt that cannot be executed during cold months and all this has to be taken into consideration when planning the construction programme. In summer there are also activities that may not be executed when the temperatures are too high, an example to such is chemical stabilisation of soils.

C4.2.4 Wind

Prevailing winds are predominantly north/north/westerly from December to January and the average daily wind speed is 14 km per hour.

C4.2.5 Climatic Classification Region

The study area falls within the Transvaal System and more specific the Pretoria Series. The group is primarily underlain by quartzite, shale, hornfels, calcareous layers and agglomerate. It can be expected that there are silty clayey deposits in the flood plains and stream beds of the rivers (streams) crossing the area. refer Figure C4.5,

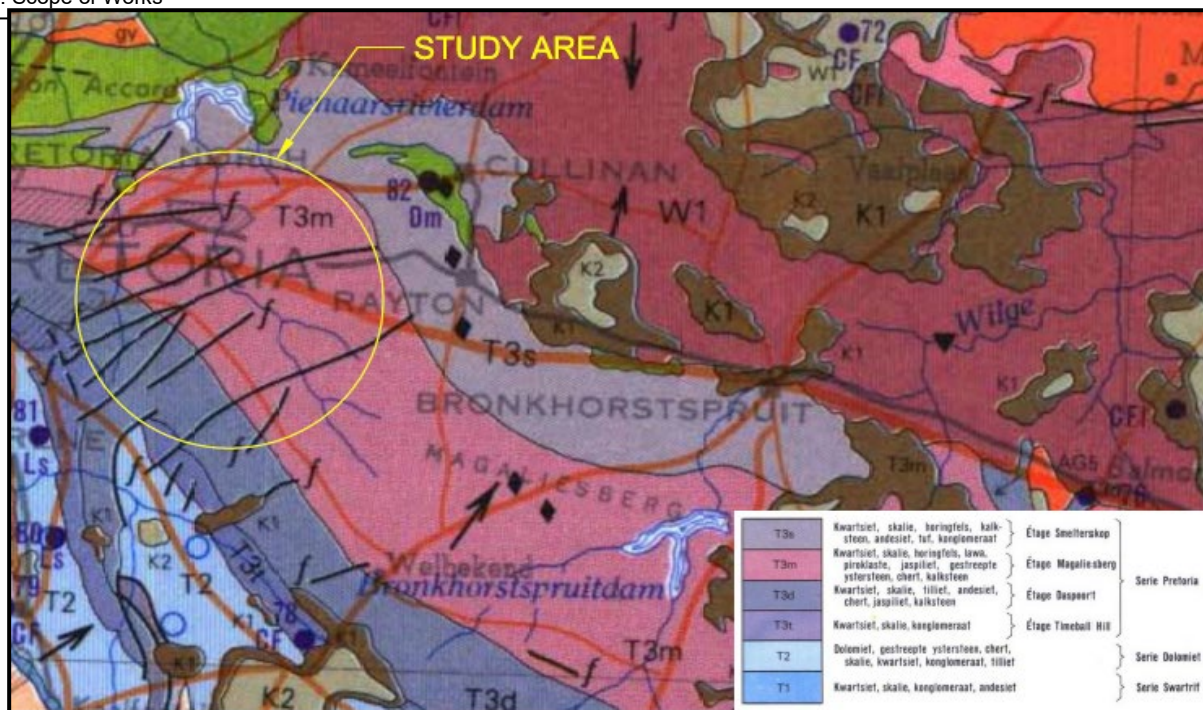

FIGURE C4.5: GEOLOGICAL MAP OF PROJECT AREA

PART C5: APPENDICES

TABLE OF CONTENTS

C5.1	ENVIRONMENTAL MANAGEMENT PROGRAMME (EMPR)
C5.2	PROJECT HEALTH AND SAFETY SPECIFICATION and BASELINE RISK ASSESSMENT
C5.3	WATER INTERRUPTION PROCEDURES
C5.4	ELECTRICAL SPECIFICATION

PART C5.1: ENVIRONMENTAL MANAGEMENT PROGRAMME (EMPR)

PART C5.2: PROJECT HEALTH AND SAFETY

SPECIFICATION and BASELINE RISK ASSESSMENT

PART C5.3: WATER SUPPLY INTERRUPTION

My ref: _____ Tel: 012 358 8001
 Your ref: _____ Fax: 086 210 1604
 Contact person: G Phillipson Email: glaudip@tshwane.gov.za
 Section/Unit: Water Consumer Operations Management Date: 20 March 2014

MEMORANDUM

WATER SUPPLY INTERRUPTION REQUIREMENTS AND SPECIFICATIONS

The following information is required **at least ten working days** before the water supply interruption date in order to communicate and advertise water supply interruption.

Requirement	To be completed
Interruption date	
Affected suburbs	
Affected wards	
Boundaries and map of affected area	
Number of households affected	
Responsible project manager	
Responsible section	
Contact details	
Signed or approved memorandum from the Director of the relevant section	
Cost centre number	
GL number	
WBS number	
Approval from Pro-active Maintenance Construction: Departmental Works	
Will water tankers be used? If yes , please provide details of arrangements made regarding this.	
Names of hospitals, schools, old age homes, business and shopping centres affected <i>A5 flyers to be circulated to these institutions</i>	

Procedure of notices (Mark with X)	Engineer to print and distribute	<input type="checkbox"/>	City of Tshwane vendor or tender	<input type="checkbox"/>
--	----------------------------------	--------------------------	----------------------------------	--------------------------

The Water Consumer Operations Management (WCOM) Subsection (Glaudi Phillipson or Danett van Niekerk) will be responsible for the following:

1. A memorandum will be sent to the Communication, Marketing and Events Department.
2. The Communication, Marketing and Events Department will inform the applicable media (radio stations and newspapers).
3. A memorandum will be sent to the following persons via email:
 - Relevant ward councillors
 - Regional Directors
 - Hospitals, schools, old age homes, businesses and shopping centres
4. The notice will be placed on the intranet and external website.
5. The City of Tshwane vendor will be instructed to print and distribute posters and flyers and to remove them after the interruption date.

If the external engineer or contractor prefers to use a private company for the printing and distribution, it will remain the responsibility of the Director/Functional Head/Project Manager to ensure that posters and flyers are distributed at least two working days before the interruption date and removed after the interruption date.

The spreadsheet obtained from the WCOM Subsection should also be completed and signed by each individual that will receive a flyer. Photographs of the posters should be taken and sent back to WCOM along with the spreadsheet.

Specifications for A1 posters (see attached example)

1. Printed on A1 Correx board.
2. Printed in full colour.
3. Attached on street light poles – not on traffic lights, signs or street names.
4. Placed in suitable places for all residents to see (entrances at shopping centres, main routes, etc).
5. Removed immediately after the interruption date.

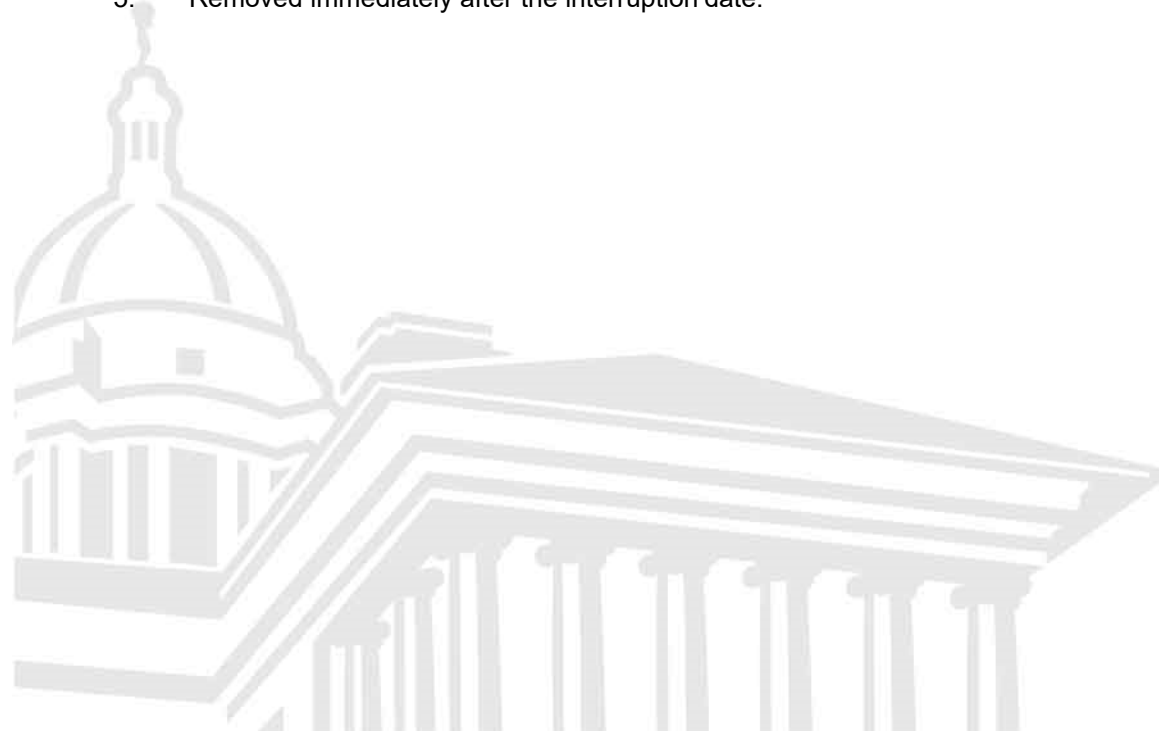

Specifications for A5 flyers (see attached example)

1. Printed on white paper.
2. Printed in black OR full colour.
3. Distributed to all institutions as specified on page one.
4. Delivered by hand.
5. Spreadsheet should be completed with signatures of individuals or institutions that received a flyer.

Director Name DIRECTOR: SECTION

Regional Director Name REGIONAL DIRECTOR: SECTION



Example – A1 Poster

WATER SUPPLY INTERRUPTION

Date: 13 February

Time: 06:00 – 19:00

Where:

**Annlin, Magalieskruin,
Pretoria North, Sinoville, Wolmer,
Grootvlei, Waterval, Wonderboom**

**Water and Sanitation
Enquiries: 080 111 1556 /
012 358 2111**

www.tshwane.gov.za



Example – A5 Flyer



The flyer features a green header with the title 'WATER SUPPLY INTERRUPTION'. Below the title, the date and time '13 February 2014 06:00 – 19:00' are displayed. A central graphic shows water splashing over a list of affected areas and water-saving tips. The affected areas are listed on the left, and the tips are on the right. At the bottom, contact information for Water and Sanitation is provided, along with social media icons and the City of Tshwane logo.

WATER SUPPLY INTERRUPTION

13 February 2014
06:00 – 19:00

- Annlin
- Magalieskruin
- Pretoria North
- Sinoville
- Wolmer
- Grootvlei
- Waterval
- Wonderboom

Water saving tips during the duration of water interruptions.

- Do not leave taps open during the duration of water interruptions.
- Make sure to fill up containers for washing and drinking purposes.
- Use the bath water for watering your garden
- Use swimming pool water for flushing the toilet
- Use piped water sparingly during interruptions
- Remember to provide water for animals

Water and Sanitation
Enquiries: 080 111 1556 /
012 358 2111
www.tshwane.gov.za

CITY OF TSHWANE
IGNITING EXCELLENCE



PART C5.4: ELECTRICAL SPECIFICATION

PART 5.4 PROJECT SPECIFICATIONS: ELECTRICAL

PART 5.4 PROJECT SPECIFICATIONS: ELECTRICAL

TABLE OF CONTENTS

SECTION B1: GENERAL

- B1.1 REGISTRATION AS AN ELECTRICAL CONTRACTOR
- B1.2 TESTS
- B1.3 MAINTENANCE OF INSTALLATIONS
- B1.4 REGULATIONS
- B1.5 NOTICES AND FEES
- B1.6 QUALITY OF MATERIALS
- B1.7 SCHEDULE OF MATERIALS
- B1.8 CERTIFICATE OF COMPLIANCE

SECTION B2: QUALITY SPECIFICATION

- B2.1 GENERAL
- B2.2 REGULATIONS LAWS AND BY-LAWS
- B2.3 ELECTRICAL/ELECTRONIC EQUIPMENT
- B2.4 TERMINOLOGY
- B2.5 LIAISON
- B2.6 SUPERVISORY STAFF AND IDENTIFICATION
- B2.7 SETTING OUT OF WORKS
- B2.8 ERECTION OF EQUIPMENT
- B2.9 CERTIFICATE OF COMPLIANCE BY AN ACCREDITED PERSON
- B2.10 INSTALLATION TESTS
- B2.11 MATERIAL
- B2.12 DELIVERY AND COMPLETION
- B2.13 DRAWINGS
- B2.14 LEVELLING AND PLUMBING
- B2.15 UNDERGROUND CABLE NETWORKS
- B2.16 INSTALLATION OF CABLES
- B2.17 ELECTRICAL LV SUPPLY CABLES
- B2.18 SLEEVES
- B2.19 CABLE MARKERS
- B2.20 LABELS AND NOTICES
- B2.21 CONDUCTORS
- B2.22 EQUIPMENT OF SWITCHBOARDS AND DISTRIBUTION KIOSKS
- B2.23 COMPLIANT LUMINAIRES & SIMULATION REPORTS
- B2.24 LUMINAIRE AND LED MODULE LIFESPAN
- B2.25 LIGHTING DESIGN LIFE CYCLE COST
- B2.26 LIGHTING ENERGY MANAGEMENT AND CONTROL SYSTEM
- B2.27 PHOTO- ELECTRIC SWITCHES
- B2.28 ITS AND TELECOMMUNICATION SERVICES

SECTION B3: PARTICULAR SPECIFICATION

B3.1 MEASURING AND PAYMENT PRINCIPLES

B3.2 CALCULATION OF QUANTITIES

B3.3 SCHEDULED ITEMS

B3.3.1 GENERAL ITEMS: ELECTRICAL – SECTION C2.2.1

B3.3.2 RETICULATION SYSTEM – SECTION C2.2.2

B3.3.3 TRENCHING AND EARTHWORKS – SECTION C2.2.3

B3.3.4 LUMINAIRES – SECTION C2.2.4

B3.3.5 POLES AND MASTS – SECTION C2.2.5

B3.3.6 MAST FOUNDATIONS AND EARTHING – SECTION C2.2.6

B3.3.7 EARTHING – SECTION C2.2.7

B3.3.8 OTHER SERVICES – SECTION C2.2.8

SECTION B1: GENERAL

B1.1 REGISTRATION AS AN ELECTRICAL CONTRACTOR

The contractor is responsible for the completion and submission of the required application forms, in respect of registration, to the supplying authority. A copy of the registration form must be forwarded to the engineer or its representative as soon as possible after the contract has been allocated. The electrical installation may not commence before the registration certificate and proof that the particular electrician is registered as an installation electrician has been received.

The successful Tenderer/electrical sub-contractor must be registered as an Electrical Contractor with the Electrical Contracting Board of South Africa, with the Workmen's Compensation Commissioner and the Unemployment Insurance Commissioner to qualify for this contract.

The successful Tenderer must complete the following questionnaire and submit it to the engineer before any work is commenced.

THE SUB-CONTRACTOR APPOINTMENT MAY NOT BE CONSIDERED UNLESS ALL THE NECESSARY INFORMATION HAS BEEN SUBMITTED.

Has the company been registered as an electrical contractor with the Electrical Contracting Board of South Africa?

YES	NO
-----	----

Registration No.:

Date of issue :

Has the company been registered with the:

1. Department of Manpower? Registration No.:

YES	NO
-----	----

Date of issue :

2. The Workmen's Compensation Commissioner? Registration No.:

YES	NO
-----	----

Date of issue :

3. The Unemployment Insurance? Registration No.:

YES	NO
-----	----

Date of issue :

I/We certify that the above information is correct and undertake to comply with the provisions in Regulation 4(2) and 6(1) of Government Notice R2920 of 23 October 1992 promulgated under Section 35 of the Occupational Health and Safety Act, No. 85 of 1993.

SIGNATURE OF TENDERER:

DATE:

NAME OF TENDERER:

ADDRESS:

Regulation (4) 2 read as follows:

CONSTRUCTION

Except in the case of electrical installations supplied by a single-phase electricity supply at the point of supply, an accredited person shall exercise general control over all electrical installation work being carried out and no person shall allow such work without such control.

Regulation 6(1) reads as follows:

COMMENCEMENT OF AND PERMISSION TO CONNECT INSTALLATION WORK

No person shall commence with installation work which would require a new electricity supply or an increase in electricity supply capacity unless the supplier has been notified thereof: Provided that the supplier may waive this requirement in respect of such types of work as he may specify.

(In your own interest you are advised to obtain a copy of Government Gazette No. 9968 of 11 October 1985 from the Government Printer in Pretoria).

SIGNED BY TENDERER:

.....

B1.2 TESTS

(a) General

The engineer may call for the inspection or testing of all or any goods forming the subject of the Contract. The engineer reserves the right to attend or not to attend any of the inspections, tests or commissioning. Whether, the engineer attends these or not, written reports and test results shall be submitted to the engineer for approval. The Contractor shall replace any portion of the installation, which does not meet with the requirements of the Wiring Code, relevant SABS standards or this Specification, or the local bye-laws as may be found by test or inspection. Such replacement shall be done at his own cost.

(b) Tests and Inspections by Local Authorities

The entire installation shall be tested after completion in accordance with the Wiring Code and any applicable by-laws of local authorities. The Contractor shall assist the Inspectors of the local authorities during any tests carried out by them and shall supply tools, instruments and consumables for testing purposes.

The Engineer reserves the right to be present at any tests and the Contractor shall inform the Engineer of all tests to enable him to be present if he so desires. The Engineer may perform similar tests at any time and the Contractor shall render all assistance and shall provide all tools and instruments, which may be required for such tests. The work specified in this document shall not be considered to have been completed until the installation inspectors of the responsible authorities have issued a clearance certificate for the electrical installation.

(c) Acceptance Tests

After completion, either in a part or as a whole the complete installations shall be subject to acceptance tests by the Engineer. The Contractor shall assist the Engineer during any test carried out and must supply tools and instruments for testing purposes.

(d) Test and Commissioning Instruments, Labour and Consumables, etc.

All labour, power, fuel, dummy loads and all instruments and appliances that may be required for the tests and commissioning shall be provided by the Contractor. Test instruments used to demonstrate capacities and characteristics specified or offered shall be tested for accuracy by an approved laboratory or by the manufacturer and certificates showing degree of accuracy shall be furnished to the engineer.

If gauges, thermometers, etc. which are to be left permanently installed are used for tests, they shall not be installed until just prior to the tests to avoid possible changes in calibration.

(e) Test and Commissioning Certificates and Records

The engineer reserves the right to attend or not to attend any of the inspections, tests or commissioning. Whether, the Employer or engineer attends these or not, written reports and test results shall be submitted to the engineer.

All certificates shall be in English.

All test and commissioning forms shall be completed in rough or final form during these operations. All test certificates are to be countersigned by the Engineer as "witnessed" or "accepted" or "seen". Four copies of test and commissioning certificates shall be handed over to the Engineer. Handover of the certificates and records is a prerequisite for handover of the installation.

With Final Acceptance the Electrical Contractor shall accept in writing the responsibility for the total installation as installed by him certifying the correctness of the installation in accordance with and on the certificates of Compliance of electrical works. The contractor shall also be responsible to have the sections required to be completed by the Engineer and the Owner completed by them as required.

Copies of the completed certificates shall be distributed as follows:

- i. Head Office of the owner – for retention in Main Planning File.
- ii. Regional Office of the owner – for retention in Regional Control file.

After completion of the works and before first delivery is taken, a full test (including a full load test) will be carried out on the installation for a period of 30 days, 24 hour operation per day thereof, to determine the satisfactory working thereof for which the system is to operate fault free for 30 days (if a fault occurs, it is to be rectified and the 30 day test period will reset). During this period the installations will be inspected and the contractor shall make good, to the satisfaction of the Engineer, any defects which may arise.

The contractor shall provide all instruments and equipment required for testing and any water, power and fuel required for the commissioning and testing of the installations at completion.

B1.3 MAINTENANCE OF INSTALLATIONS

With effect from the date of the First Delivery Certificate the contractor shall at his own expense undertake the regular servicing of the installation during the Defects Liability Period and shall make all adjustments necessary for the correct operation thereof.

If during the said period the installation is not in working order for any reason for which the contractor is responsible, or if the installation develops defects, the contractor shall immediately, upon being notified thereof, take steps to remedy the defects and make any necessary adjustments. Should such stoppages however be so frequent as to become troublesome, or should the installation otherwise prove unsatisfactory during the said period the contractor shall, if called upon by the Engineer, at his own expense replace the whole of the installation or such parts thereof as the Engineer may deem necessary, with apparatus specified by the Engineer.

Luminaires will be tested upon the completion of the Defects Liability Period for compliance to the contract specifications. If the test results indicate non-compliance the contractor shall, by instruction by the Engineer, at his own expense replace the whole of the installation or such parts thereof as the Engineer may deem necessary, with apparatus specified by the Engineer.

B1.4 REGULATIONS

The installation shall be erected and tested in accordance with the following Acts and regulations:

Tshwane material specifications

- a) ESMS0001: Underground paper insulated 11kV copper cable.
- b) ESMS0002: Underground polyethylene-insulated petroleum-jelly filled telephone-type pilot cable,
- c) CTMME-IS60: Streetlights Installation Specification
- d) ESMS0007: LV cable jointing accessories.
- e) ESMS0009: Accessories for MV power cables for systems with nominal voltages of 11kV to 33kV
- f) ESM0015: Street lighting luminaires.
- g) ESM0021: Photo electric control unit (PECU)

Standards

- h) SANS 1277: Streetlighting Luminaires
- i) SANS 10225:1991 : Design and construction of Lighting masts
- j) SANS 1088:2004 : Luminaires entries and spigots
- k) The latest issue of SANS 10142-1: "Code of Practice for the Wiring of Premises-Part 1: Low Voltage Installations",
- l) The latest issue of SANS 475: 2005: "Code of Practice for Streetlight Luminaires",
- m) The latest issue of SANS 10098-1: "Lighting of public thoroughfares", to be regarded as a standard,
- n) The latest issue of SANS 10098-2: "Lighting of certain specific areas of streets and highways", to be regarded as a standard,
- o) The latest issue of SANS 10389-1: "Exterior Lighting Part 1: Artificial lighting of external areas for work and safety"
- p) The Occupational Health and Safety Act, 1993 (Act 85 of 1993) as amended,
- q) The Local Government Ordinance 1939 (Ordinance 17 of 1939) as amended and the municipal by-laws and any special requirements of the local supply authority,
- r) The Fire Brigade Services Act 1993, Act 99 of 1987 as amend,
- s) The National Building Regulations and Building Standards Act 1977 (Act 103 of 1977) as amended,
- t) Electrical Installation Regulations of 1992 promulgated under section 35 of the Machinery and Occupational Safety Act of 1983 (Act No. 6 of 1983)
- u) The Post Office Act 1958 (Act 44 of 1958) as amended,
- v) The Electricity Act 1984 (Act 41 of 1984) as amended,
- w) The Regulations of the local Gas Board where applicable.
- x) The latest issue of SABS 150
- y) The latest issue of SANS 97
- z) The latest issue of SANS 1339
- aa) Relative Municipal Authority standards and specifications, and

It shall be assumed that the Contractor is conversant with the above-mentioned requirements.

Should any requirement, by-law or regulation, which contradicts the requirements of this Document, apply or become applicable during erection of the Installation, such requirement, by-law or regulation shall overrule this Document and the Contractor shall immediately inform the Engineer of such a contradiction.

Under no circumstances shall the Contractor carry out any variations to the installation in terms of such contradictions without obtaining the written permission to do so from the Engineer. No claims for extras

in respect of failure by the Contractor to comply with any of the above regulations will be considered. Where conflict exists between any of the above regulations and the specifications, the said conflict must be referred to the Engineer in writing for his ruling in writing.

B1.5 NOTICES AND FEES

The successful Tenderer for this Contract shall, immediately after he has been officially notified that his tender has been accepted, and at any time thereafter as may be necessary, notify all the relevant authorities, pay fees including inspection and re-inspection fees and take any other steps which may be required or prescribed to execute the installation as specified.

Copies of such correspondence with the relevant authorities shall be forwarded to the Engineer who shall at all times be kept informed. Submission of copies to the Engineer to keep him informed does not relieve the Services Contractor of his responsibilities in terms of the contract. The Employer will pay the connection fee payable to the local electricity supply authority for the permanent electrical supply/connection, or, where paid by the Contractor, the Employer upon presentation of the receipt will reimburse him.

B1.6 QUALITY OF MATERIALS

Only materials of highest quality shall be used and all materials shall be subject to the approval of the engineer. Wherever applicable, the material shall comply with the relevant South African National Standards, specifications, or to IEC or British Standards Specifications, where no SANS Specifications exist, and shall be approved, installed and commissioned in accordance with these Specifications and Codes and to the satisfaction of the engineer. Materials and equipment used in this Contract shall, where possible, be of South African manufacture and shall comply with this Specification and relevant SANS, BS or IEC Specifications and Codes

Where a certain manufacturer's material or apparatus is mentioned in the drawings or specifications, such materials or apparatus shall be provided as specified, excepting where an alternative to this condition is allowed in the specifications, but the engineer shall have the final decision. Where a detailed specification for material or apparatus is not provided, it shall be understood that all normal requirements for the use of such material or equipment shall apply.

Should the Contractor base his tender price on any alternative and this alternative is rejected by the engineer, any cost implication this may have shall be for the Contractor's account. Tender prices may be based on alternatives to those items specified in this specification or where a written addendum to this tender document specifying allowable alternatives is issued during the tender period by the Engineer.

Alternatives for specified equipment will only be considered during the first 8 weeks from the date of the letter of appointment of the Contractor, as issued by the Engineer. Only the Engineer shall have the right to grant the contractor permission to change the equipment and / or material subsequent to the award of the contract.

Should alternatives be offered by the Contractor, the following is required:

- A sample and technical pamphlet and data of the specified item
- A sample and technical pamphlet and data of the alternative or substitute offered
- Price implication per item for the alternative or substitute together with substantiating invoices or

quotations

- Price implication for the entire installation for the alternative or substitute. This price implication should be itemised listing every item applicable separately and totalling them.

The Contractor shall submit samples of all materials or equipment for approval by the Engineer before installation, unless prior approval to the contrary has been obtained in writing from the Engineer. Such samples will be held for purposes of comparison with equipment and materials installed and will be released on satisfactory completion of the Contract.

The Engineer may instruct the Contractor to supply and/or deliver and/or install any other make or manufacture of article(s) than that/those specified and will issue a variation order where such a change has cost implications. Where certain products of a specified manufacturer are unobtainable, substitutions may be offered, but shall only be supplied after written consent by the Engineer.

Where plastic materials are used in areas exposed to direct sunlight, they shall be treated for/protected against the effects of Ultra Violet light. Where materials and equipment are to be installed exposed to the elements or in corrosive or explosive environments, the materials of the equipment and for holding down the equipment shall be selected taking due note of these conditions.

B1.7 SCHEDULE OF MATERIALS

In all instances where schedule of power points, luminaires, poles and kiosks are attached to or included on the drawings, these schedules are to be regarded as forming part of the specification. Except in the case of electrical installations supplied by a single-phase electricity supply at the point of supply, an accredited person shall exercise general control over all electrical installation work being carried out.

The workmanship shall be of the highest grade and to the satisfaction of the Engineer. All inferior work shall, on indication by the Engineer's inspecting officers, be immediately removed and rectified by and at the expense of the contractor. All equipment and fittings supplied must be in accordance with the attached quality specification (of this document), suitable for the relevant supply voltage and frequency and must be approved by the Engineer.

Notes to tenderer:

1. For the purpose of clarity when using this form, a supplier is any company (including refineries) that supplies to a tenderer an electrical & road lighting product that it manufactures. A tenderer shall, in compliance with note 2 below, attach to this form a letter of supply from each supplier it intends using in the performance of the contract.
2. Tenderers shall append to this page the following information on a letterhead from their selected supplier:
 - the supplier's company registration and address details; and
 - the product range available; and
 - the net base product type and content for each product; and
 - the supply price (excluding VAT but including all other obligatory taxes and levies) to the tenderer for the net product base content of each product; and
 - the date from which the supply prices apply.
3. A change of supplier may be permitted, but only upon application to the engineer with the appropriate letters of supply in compliance to Note 2 above and approval thereof.

4. Non-disclosure of reduction in supply prices shall be deemed a contractor's deliberate action to defraud the Employer and grounds for the Employer, at its sole discretion, to terminate the contract.

Each material and equipment dealt with is stated in the list below. The rates and prices for the equipment and materials shall be furnished by the tenderer as an attachment to this Form, which rates and prices shall not include VAT but shall include all other obligatory taxes and levies.

The schedules must only be completed insofar as the equipment and materials required for this particular contract are concerned. If these schedules are not properly completed by the Tenderer, his bid document will be regarded as incomplete.

Where types, etc. are filled in below and these do not comply with the Specification, this must be specifically pointed out by the Tenderer. Filling in of types, etc. below does not signify that they are acceptable or will be accepted, if they do not comply. All material proposed can only be changed when prior written approval is received from the engineer.

B1.7.1 CABLES, CONDUCTORS AND ACCESSORIES

EQUIPMENT AND MATERIAL	UNIT	RATE OR PRICE FOR BASE MONTH	DESCRIPTION AND MAKE
11kV PILC 3C SWA Cable			
11kV PILC 3C Cable Joints			
PVC SWA ECC PVC XLPE Cable			
PVC SWA ECC PVC XLPE Cable Joints			
PVC SWA PVC LV Cable terminations			
GP PVC Wire			
GP PVC Wire terminations			
Earth Conductor			
1.5m Earth Spike			
Exo-Thermic Jointing (Cadweld)			

B1.7.2 MINI SUBS, DISTRIBUTION KIOSKS AND EQUIPMENT

EQUIPMENT AND MATERIAL	UNIT	RATE OR PRICE FOR BASE MONTH	DESCRIPTION AND MAKE
12 Way LV Kiosk (Vandal Resistant)			
LV Kiosk Security System			
Miniature Circuit Breakers (MCB)			
Contactors			
Photo-electric switch			
Surge Protection			

B1.7.3 LUMINAIRES

TYPE	UNIT	RATE OR PRICE FOR BASE MONTH	SUPPLIER AND PRODUCT TYPE
------	------	------------------------------	---------------------------

L1			
L2			
Lighting energy management and monitoring control system for entire installation			

B1.7.4 POLES AND HIGH MASTS

Mounting Height	UNIT	RATE OR PRICE FOR BASE MONTH	MANUFACTURER, CONSTRUCTION AND TYPE
10.50m MH pole			

B1.7.5 CIVIL WORKS

TYPE	UNIT	RATE OR PRICE FOR BASE MONTH	MANUFACTURER, CONSTRUCTION AND TYPE
Mast foundations			
Service sleeves			

B1.8 CERTIFICATE OF COMPLIANCE

On completion of the service, a certificate of compliance shall be issued for each Mini-sub, LV Kiosk and LV cable feed, to the Engineer in terms of the Occupational Health and Safety Act, 1993 (Act 85 of 1993).

SECTION B2: QUALITY SPECIFICATION

B2.1 GENERAL

This Quality specification defines the Generals of materials and equipment, installation work and ancillary work to be employed in the electrical installation contract or sub-contract. The Project Specification defines the extent of work required.

B2.2 REGULATIONS LAWS AND BY-LAWS

The supply and installation of the work shall be in agreement with the Conditions of the Contract with special attention to the following in particular:

- a) The Occupational Health and Safety Act no. 85 of 1993, as revised, whereby SANS 10142 is enclosed.
- b) Government notices.
- c) The local Municipal By-laws and any special requirements of the local supply authorities.
- d) The local Fire Office Regulations.
- e) Telkom Regulations
- f) Any special conditions specified in this specification.

It must be clearly understood that, where differences in the Generals occur as stated in (a), (b), (c), (d), (e) and (f) or where additional requirements are required, the higher General requirements shall apply. In the event of any contradiction between (a), (b), (c), (d), (e) and (f), then (f) shall be accepted above the rest. Where any required by-law or regulation, which applies or becomes applicable during the execution of the electrical installation, is in conflict with the stipulation of the document, the former must have preference in all cases. The contractor must immediately notify the Engineer of such discrepancies. The contractor may not make any alterations to the installation before written sanction to do so is received from the Engineer or its representative.

B2.3 ELECTRICAL/ELECTRONIC EQUIPMENT

All the equipment must be properly protected against damage, faulty functioning or interference by any external factors such as static electricity, induced voltage, magnetizing forces, radio waves, etc., which may occur in the building.

Equipment which is sensitive to interference and interference peaks in the electrical circuit; variations in voltage and frequency such as normally occur in the electrical distribution network, and the municipal supply to the building, which are inevitable, must be fitted with the necessary stabilizers, over and under-voltage protection equipment, suppressers, etc.

Equipment must be so manufactured and installed (and provided with suppression), that it does not cause any interference to other equipment or in any way affect the functioning thereof.

B2.4 TERMINOLOGY

Labels must indicate the functions of equipment and components in the distribution boxes and/or distribution boards.

The terminology on the identification labels must be in English.

B2.5 LIAISON

The electrical contractor shall, in each case, provide the engineer, employer (principal contractor) with all necessary information, dimensions, materials, etc., as called for in the specification, in good time. It is essential that the electrical contractor work in close collaboration with the principal contractor to ensure that where his services run in proximity with other services, there are no clashes. Failure to comply with the above may mean that corrective measures will have to be taken to correctly position the equipment. Any abortive work resulting will be entirely to the electrical contractor's account.

Where the electrical contractor is to provide electrical supplies to control panels forming part of other contract works, it is essential that the electrical contractor liaise fully with the particular contractor who must provide the electrical contractor with all information necessary so as to ensure that the supply cable terminates in the correct position and that the phase rotation complies with the equipment installed. Failure to do so may result in the electrical contractor being held responsible for the cost of removing and replacing not only his own but also the equipment of the main contractor and other contractors.

B2.6 SUPERVISORY STAFF AND IDENTIFICATION

All work done on site shall at all times be under the direct and full time supervision of a contract manager who shall be a qualified installation electrician who will sign the certificate of compliance.

Full particulars of the site organisation, complete with names of officials the Tenderer proposes to allocate to this project are to be submitted with this tender. For the duration of this contract the above detailed officials will be permanently assigned to this project and may only be relieved of their duties after prior agreement by the Engineer or his representative/agent. Whilst on the site all staff and labourers employed by the electrical contractor shall wear distinctively marked clothing bearing the name of the electrical contractor or his identification logo.

B2.7 SETTING OUT OF WORKS

The electrical contractor shall be responsible for marking out and setting out of all equipment and plant. The position of items of electrical equipment and plant indicated on the drawings are to be taken as approximate. The exact position for fixing shall be obtained by site measurements. In case of doubt, decisions shall be obtained from the Engineer or his representative/agent.

B2.8 ERECTION OF EQUIPMENT

The contractor shall be responsible for the erection and installation of all equipment supplied by him under this contract.

In addition, the contractor shall be responsible for the care and maintenance of all electrical equipment after erection is completed until the first delivery of the specific section of the works. He shall ensure that the proper enclosure of all equipment is maintained at all times, that access doors and covers are opened only when necessary to work on the equipment and replaced afterwards, that the paint finish on all items

is effectively protected and that all unused cable and conduit entries are effectively sealed.

B2.9 CERTIFICATE OF COMPLIANCE BY AN ACCREDITED PERSON

On completion of the electrical installation the contractor shall complete the Certificate of Compliance for the electrical Installation in the form of Annexure 1 as described in the Occupational Health and Safety Act no. 85 of 1993, as amended, and obtainable from the Electrical Contracting Board of South Africa. This form must be handed to the Engineer or its representative.

B2.10 INSTALLATION TESTS

Tests as stipulated in the "Occupational Health and Safety Act no. 85 of 1993, as amended, and in the "Code of Practice for the Wiring of Premises" SANS 10142 (as amended), must be done. These test report forms must be filled in fully and correctly in ink, signed by the installation electrician and handed to the Engineer or its representative.

Tests must be conducted on site after the whole installation is complete, unless written the Engineer to the contrary grants permission. The tests must include a full-load test for an adequate period to ensure the satisfactory working of the installation. If negative test results are obtained, faults must be rectified and tests again done. The contractor must supply all testing apparatus, correctly calibrated.

All tests shall be carried out in conjunction with and to the satisfaction of the Supply Authority and in the presence of the Engineer or his representative. The contractor shall make all arrangements for testing and inspection, the costs thereof being included in the Tender Price.

Each length of cable shall be tested for insulation and polarity by means of a 2000 Volt Megger for LV and 22kV low frequency tester on 11kV cables designed for that purpose. In the case of underground cables this shall be done before back filling. In addition, the earth-loop impedance of each conductor earth electrode shall be measured. The earth resistance shall be tested by means of an approved instrument. "Danger" notices shall be displayed at remote ends of cables under test.

The contractor shall ensure that the installation is completed in every respect and that there are no major defects prior to notifying the Engineer (in writing) for a first delivery inspection. The Engineer will accept zero minor defects during the final inspection. Should the number of defects be exceeded at the final inspection then the Engineer will terminate that inspection and request that the contractor arrange an additional final inspection.

B2.11 MATERIAL

Materials and equipment used in this installation must be of the best quality of their respective types, must meet the relative SANS or BSS specifications and must be installed to the satisfaction of the electrical Engineer or his representative.

The contractor will be informed in writing if any material or workmanship is not of the required quality. In such a case the contractor must replace the material concerned or repair the installation to the satisfaction of the Engineer or its representative. If requested to do so, the contractor must provide samples of materials or equipment, for the approval by the electrical Engineer, before it may be installed. The samples will be kept for comparison with materials and equipment actually installed and will be returned after the contract has been satisfactorily completed.

B2.12 DELIVERY AND COMPLETION

All contract materials shall be ordered timeously and delivered to site at dates suited to the agreed construction program. The successful Tenderer for the installation will be required to commence work immediately following notification of tender acceptance and shall thereafter at all times maintain the progress required by the agreed completion program.

B2.13 DRAWINGS

As soon as is possible after the contract has been awarded to him, the contractor must submit two (2) copies of the following drawings to the Engineer for approval:

Design and construction drawings of all distribution kiosks, poles, and foundation details as specified. The following information must appear on the drawings:

- (a) A full layout with the arrangement of the equipment in the distribution kiosks, and on which all measurements of the equipment and the construction are indication.
- (b) The position, fastening method and current rating of the bus bars.
- (c) The make, catalogue number and capacity of insulators, circuit breakers, fuses, contactors, etc.

The Engineer's acceptance of these drawings does not release the contractor from his responsibility to supply the material in terms of this contract. Submit to the Engineer duplicate prints of dimensioned general arrangement drawings of all switchboards, distribution boards, motor control centres, control boards and consoles, busbar trunking systems, rising mains systems, etc. Attend upon the Engineer, preferably with the manufacturers of the equipment, to discuss and agree any changes required in the drawings.

Modify makers' drawings as directed and, after acceptance by the Engineer, provide at least four prints of each for distribution to the parties to the contract. On completion of the project update the drawings with any changes made during the course of the contract works and furnish the Engineer with the necessary prints for record purposes.

B2.14 LEVELLING AND PLUMBING

All equipment shall be carefully levelled and plumbed, checked with a spirit level. Should any equipment be unsatisfactorily installed in this respect it shall be dismantled and reinstalled, the costs of making good to damaged structures, plaster and paint will be for the account of the contractor. It must be noted that boxes for imported accessories must be levelled and plumbed when installed, since the inserts cannot be levelled independently of the boxes.

B2.15 UNDERGROUND CABLE NETWORKS

2.15.1 Scope

This specification covers the laying and joining of cables for underground high-voltage and low voltage systems.

2.15.2 Interpretation

2.15.2.1 Supporting Specification

The following specifications are part of this specification.

- a) SANS 97 : Electrical cables with impregnated paper insulation
- b) SANS 1507 : Electrical cables and flexible cords with poly-vinyl chloride (PVC) insulation
- c) SANS 10198 : The choice, handling and installation of electrical power cables with a rating not exceeding 33 kV
- d) SANS 1200 C : The cleanup of the site
- e) SANS 1200 DA : Ground works (small jobs)
- f) SANS 1200 DB : Ground works (pipe trenches)
- g) SANS 1200 LB : Scatting (pipes)
- h) SANS 1200 LC : Cable ducts
- i) SANS 1339 : Electrical cables with insulation of cross-linked polyethylene (XLPE)
Insulated Electric Cables
- j) SANS 1053:201 : Accessories doe medium- voltage power cables (3,8/6,6 KV to 19/33KV)
- k) NRS 028 : Cable lugs and ferrules for copper and aluminium conductors

2.15.2.2 Implementation

This specification includes clauses which is in general applicable to underground network systems for electrical power supply. The interpretation of, and variations to this specification is explained in Section 2 of the project specification.

2.15.2.3 Terminology

The terminology in the applicable supporting specifications, as given in 2.1 and the following terminology applies to this specification.

Core

A single insulated conductor without any protective housing.

Screened cable

A cable in which every core is separately encased by a conducting layer to ensure that the conductor is surrounded by a radial electric field when it is energised.

Belted cable

It is a multi-core cable where a part of the insulation covers each conductor and the rest of the insulation covers the combined cores.

Pilot cable

A cable which is normally used for measuring (control) or safety or communication circuits or all three.

Phase sequence

The sequence in which the phase voltages of a multiphase system reach its maximum values.

High voltage (HV)

Voltages with RMS value higher than 1 000V.

Cable

A length of core (or a length of 2 or more cores, laid up) which, in total, can be provided with a mechanical housing.

Low voltage (LV)

Voltages with RMS value of 1 000 V or lower.

Mass impregnated non-draining cable (MIND)

A cable of which the surplus impregnated-agent was not removed during production because the cable is non- migrating at the conductor's working temperature.

Ambient temperature

The temperature of the air 400mm above ground level at the bottom of the ditch, where applicable.

Thermal resistivity

The resistance against the flow of heat in a dielectric (Unit : K.m/W).

Consumer distribution unit (CDU)

A switch-box for LV service connections connecting the network and one or more consumer supply points.

2.15.2.4 Abbreviations

The abbreviations in the applicable part of the specification given in 2.1 and the following abbreviations apply to this specification.

Al	:	Aluminium
Cu	:	Copper
CNE	:	Combined neutral and earth
CDU	:	Consumer distribution unit (LV – distribution connecting box)
HV	:	High voltage
LV	:	Low voltage

MIND	:	Mass impregnated non-draining cable
PME	:	Protective multiple earthing
PI	:	Plasticity index
PILC	:	Paper insulated, lead covered
PVC	:	Poly-vinyl chloride
SWA	:	Steel Wire Armour
XPLE	:	Cross-linked polyethylene cables

2.15.3 Material

2.15.3.1 Graded Backfill material

Graded backfill material must be used to cover the cable(s) and to ensure good embedding. The material

must be earth with a low clay content, with a maximum PI of 6 and a maximum resistivity of 1,2 K.m/W and must be free of all plant materials, clots and stones with diameter bigger than 15mm, except in situations where other limits are specified in the project specifications. Sea or river sand is not acceptable because of its high thermal resistivity.

2.15.3.2 Grading

The contractor may not waste excavated material that complies with 3.1 by removing it. The contractor is not compelled to use selective methods of excavation. He is allowed, (but not forced) to sift the excavated material, treat or process the material in any other way to make it suitable to cover the cable(s) and to prevent material that is suitable for fill material or main fill material to become buried or contaminated. If suitable material for graded backfill material is not freely obtainable from excavations, the contractor must obtain material from other excavations on site or by opening quarries or by importing suitable material from commercial or other approved sources.

2.15.3.4 Cable Route Markers

Cable route markers must be provided if required and according to the project specifications.

2.15.3.5 Cable Joints and Cable Terminations

Cable connections throughout the system shall follow the same phase rotation, and all cores on the system shall follow the undernote identification:

Red Phase... :	Core No. 1
Yellow / White Phase :	Core No. 2
Blue Phase :	Core No. 3

Suitable tinned lugs, terminals and other fittings shall be used to match the different sizes of stranded copper core or solid aluminium core cables. The correct type of hexagonal crimping tools shall be used to crimp the lugs, terminals and other fittings onto the copper or aluminium cores.

The costs for the supply of lugs, terminals and all other fittings shall be included in the prices for the installation of cables.

Cable joints and cable terminations must be of an approved type, e.g. heat shrink or mechanical sealing type. All cable ends must be insulated via heat shrink.

All high and medium voltage cable joints must be done by an approved artisan. Paper insulated cable joints may be done with heat shrink joints else will be encased by a cast-iron joint box, designed for this purpose. The fill material must comply with BS 1858. XPLE cables must be jointed with heat shrink joints. The electrical continuity, screening and armouring may in no way be negatively influenced by the joint.

All heat shrink terminations must be supplied as a unit, including all necessary parts. The termination must be designed for the specific cable and application. Outdoor terminations must be designed to prevent arcing under any pollution and weather conditions to which it may be subjected. The joints to be used must adhere to the local supply authority specifications and requirements.

Cable glands shall be used according to the manufacturer's recommendations. All cable glands shall be manufactured from brass. Cable shoes must be "Hex" crimped onto the cable ends with a purpose made

tool. Cable shoes must be encased with a heat shrink sleeve of which the colour corresponds with the phase of each cable core.

Clamps

One piece cable clamps with rear pressure shoes mounted on Unistrut P4000 bar can be used to clamp the cables. The armouring shall be bolted to earth bars by means of suitable lugs.

Glands

Steel wire armoured cable ends shall be made off in glands as prescribed by the manufacturers, of correct size and complete with neoprene shrouds. The armouring shall be clamped between substantial tapered sections, which form an integral part of the gland, secured by lock nuts to give a proper earth connection.

Glands shall be used for all cables to be terminated outdoors, with neoprene shrouds and suitable heat shrink covers. Where the cable enters an outdoor box, the gland shall be provided with a neoprene washer to seal off the hole.

Compression Glands

Compression type glands shall be used where specified, for armoured cables where the armouring can be taken through the gland to be bolted to an earth bar. Cable ends shall be made off in compression type glands as prescribed by the manufacturers, of correct size and complete with neoprene shrouds. The armouring together with the cable cores shall be brought through the gland and the cable shall be properly clamped by means of cable gland neoprene rings.

The armouring of the cable shall be connected to an earth bar by means of a suitable tinned cable ring. The compression type gland shall be used for all Strip Aluminium Armoured

Cables.

Cable ends shall be long enough for the making off of cable ends into cable through joint boxes and/or cable end boxes. The Contractor shall avoid excessive waste. The Contractor at his own cost shall replace excessive waste if there are any cable shortages to complete the contract, due to the wastage by the Contractor.

Compound shall conform to BSS 1858

Lead sheets, or other approved material, approximately 75mm wide, shall be clamped around the high and medium voltage cables at every cable end box and cable joint box and underneath every cable marker. The following information shall be engraved on the sheets if the manufacturer has not already printed in on the cable sheath:

- (a) Voltage, e.g : 11kV
- (b) Sizes, e.g : 185mm² Cu.
- (c) Designation, e.g : Substation 1,

The ends of cables that are cut shall immediately be sealed by means of plumbed lead end caps should there be a delay before jointing is to take place. The sealing of cable ends by means of rubber or bituminised tapes shall not be allowed. Heat shrink caps manufactured by Raychem may be used provided the seal is correctly applied. Where cable ends were open for 24 hours or more, the cable ends shall be tested for moisture.

All ends of cables are to be made off with a suitable end box (for paper cables) or gland (for PVC insulated

cables) that shall be effectively earthed and bolted to equipment or switchboards. PVC cable glands shall be complete with neoprene shroud. Sufficient slack shall be provided at each end of the cables.

Termination of Paper-insulated Cables

The ends shall be terminated in cable end boxes filled with bituminous, cold filling resin oil semi-fluid compound or heat-shrinkable terminations in accordance with the Local Authority's standard specifications.

Heat-shrinkable materials may be used unless indicated otherwise with the written permission of the Local Authority. Before terminating or jointing paper-insulated cables, a test to establish the presence of moisture must be carried out. The armouring shall be bonded to the main earth bar of the switchgear or transformer, but the bond shall be easily removable for testing purposes.

The lead sheath shall be wiped against the conical wiping gland. All cut cable ends which will be exposed to the atmosphere for more than two hours shall be sealed and wiped to prevent penetration of moisture.

Termination of XLPE Cables.

These cables shall only be used in exceptional circumstances and only with the written permission of the Local Authority and Engineer. Cross-linked polyethylene cables (XLPE) shall be terminated in accordance with the Local Authority's standard specifications.

The copper tapes of the earth screen on the cable shall be bonded to the main earth bar of the switchgear or transformer, but the bond shall be easily removable for testing purposes. The cable shall be firmly secured on the switchgear by means of a clamp to prevent mechanical stress on the cables and terminations.

Joints

Joints shall not be allowed in cable runs unless authorised by the local municipality. Jointing shall be carried out strictly in accordance with the manufacturer's instructions and by personnel competent in jointing the types of cable used.

Cable joints shall be done by means of suitable ferrules which shall be properly sweated onto the conductors. Crimped ferrules will not be accepted. Suitable tinned ferrules and flux with the correct type of aluminium soldering shall be used for aluminium cables. On underground through joints, suitable ferrules shall be used for connecting the cores together. The strands shall be thoroughly tinned before being sweated onto the ferrules.

The joint will not impair the anti-electrolysis characteristics of the cable. The Contractor shall notify the Engineer & Local authority timeously of the day on which jointing is to be carried out in order that an inspection may be arranged if so required. Any cable joint not inspected by the Engineer because of insufficient notice being given, shall be opened for inspection, and redone at the discretion of the Engineer and at the cost of the Contractor.

The Engineer reserves the right at any stage during the contract to instruct that any completed joint be opened for the purpose of carrying out an interior inspection. Should the workmanship of the joint be such that it fails to pass an inspection, the remaking of the joint shall be carried out at full cost to the Contractor. Should the workmanship pass the inspection the cost of making good the opened joint shall be the

Employer's account.

The joining of copper conductors to aluminium conductors shall be achieved by the use of properly tinned and sweated cores and ferrules respectively. The correct type of ferrules shall be used. All materials used on HV and MV Cable Joints, paper insulated or XLPE cables, shall be those recommended and accepted by the cable manufacturers and approved by the local municipality. Where cable jointing kits are used, all the components and materials used with the kits shall be used as instructed, their application being in the correct sequence as instructed by the manufacturers.

Joints shall be fully water and air tight and shall be free of voids and air pockets. The crossing of cores in joints will not be permitted under any circumstances.

2.15.3.6 Protective Concrete Slab

Where protective concrete slabs are required in the project specifications, it must have the following nominal measurements.

Length	:	1m
Width	:	230mm
Depth	:	50mm

The slabs must be manufactured of 20 Mpa concrete. Each slab must have one armament rod along the length and 3 across the width. The rods must be manufactured using mild steel with a nominal diameter of 8mm. If not, the slabs must be manufactured as specified in the project specifications.

2.15.3.7 Plastic Warning Tape

Plastic warning tape must consist of a strip of polyethylene, at least 0,04mm thick and with a nominal width of 150mm or 230mm (as specified in the project specifications). The warning tape must be totally impregnated with pigment so that it corresponds with colour no B26 (light orange) of SANS 1091 in a reasonable way. A black triangle and the flash symbol for electricity, which corresponds with sign WW7 of SANS 1186 as well as the words "DANGER, GEVAAR, INGOZI" must be printed on the full length of the tape with maximum intervals of 1 meter.

2.15.4 Construction Equipment

2.15.4.1 Compaction Equipment

Sufficient manual compaction equipment must be supplied for the compacting of the graded backfill material around and above the cables, sleeves and in trenches.

2.15.5 Installations

2.15.5.1 General

Trench excavations must comply with the requirements of SANS 1200 LC and SANS 1200 DA. No cables may be laid before the site is cleaned and the mass earthworks, which is done by others, is completed. Every trench must be kept as straight as possible and must be dug to approved levels and measurements.

The bottom must have an even contour.

Trenches dug close to railway lines, walls, roads, drains, pipes, cables, structures and on similar places where the danger of sagging exists, must be secured against such dangers and it must be done in such a way as to prevent possible injuries to construction personnel and the public. All these excavations must be done to the satisfaction of the Engineer and the public authorities concerned.

Bedding materials may not be laid until the trench has been approved by the Engineer. The Engineer might expect proof from the contractor that the minimum depth of bedding material is provided before giving authority for the cables to be laid.

2.15.5.2 Guarding, Barricades, Lighting and Traffic Intersections

The contractor must arrange guarding, barricades, lighting, and traffic intersections for work in public roads. This arrangement must comply with the applicable Road Traffic Ordinance, the requirements of the Occupational Health and Safety Act (Act 85: 1993), the project specification and the applicable requirements of sub clause 5.0 of SANS 1200 DA.

2.15.5.3 Protection of Structures

In cases where work has to be done in the vicinity of buildings, bridges, tanks or other structures, the contractor must take all the necessary precautions as required by the Occupational Health and Safety Act (Act 85: 1993) and the Mines and Industries Act of 1956, (Act 27: 1956).

These precautions shall include shoring where necessary, to ensure the safety of structures which is subject to danger during installation.

2.15.5.4 Protection of Surface and Underground Services

The contractor must take all the necessary precautions to protect all existing services (meaning services on the site, which is shown on the drawings) and he will be held responsible for all damages to these services, caused by his activities. All works and protection arrangements are subject to approval, and it must only be done after consulting the owner(s) of the various services. Should a service be damaged, the contractor must immediately inform the Engineer and the authorities concerned. The contractor may not repair the damaged service unless he is instructed to do so.

In cases where no underground services are shown on the drawings or recorded, but the possible presence thereof cannot be discarded, the contractor must, in conjunction with the Engineer, establish if any such services exist within the applicable site area. The contractor must in good time complete such investigation before construction may start on the area concerned. A report must be issued to the Engineer whom will make the necessary arrangements for the protection, removal or relaying of the services prior to the commencement of any construction work.

Upon the discovery an underground service previously not indicated on the drawings, this service will be classified as 'n known service and the contractor will be held responsible for any damages thereof during all further works. In cases where such service is damaged with the initial discovery, the Employer will cover the costs of repairing the service, except if the Employer can prove that the contractor did not take the necessary precautions and that the damage could have been prevented. Should the authorities concerned prefer to make the changes or arrangement for protection of services on their own expenses, the contractor

must co-operate with such authorities, and give reasonable access, working area and time to complete the necessary work. Permanent changes to or permanent relaying of services which is necessary to complete the work, and which is authorised, will be compensated for, there will be no compensation for work carried out and not previously investigated by the Engineer and for which no written instructions were issued.

2.15.5.5 Conduct with Respect to Water on Site

The contractor must give proper attention to water and remove it to ensure that the works are kept dry enough so the work can be properly executed. For this purpose he must provide, use and keep in order, pump equipment, water sand pens, pipes and other equipment that might be needed. He must also provide fresh drains, trenches, coffer-dams and other temporary works that might be necessary to keep damages, inconveniences and disturbances at a minimum.

2.15.5.6 Pollution

The contractor must take all reasonable precautions to the satisfaction of the Engineer to keep dust disturbance, pollution of streams and inconveniences or annoyances to the public (or others) because of the execution of the work, at a minimum.

1.15.5.7 Safety

The contractor must at all times provide proper and adequate precaution and safety arrangements on site.

Should the contractor fail to comply with this requirement, the Engineer will take the necessary steps to ensure that this requirement is met and any costs incurred will be for the contractor's account.

Complying with this requirement does not exonerate the contractor of his responsibilities and duties in accordance with the Occupational Health and Safety Act (Act 85: 1993) and mines and Industries Act of 1956, (Act 27: 1956). Symbolic safety signs must comply with the applicable requirements of SANS 1186.

2.15.5.8 Minimum Base Width of Trenches

The minimum base width of each trench must be wide enough for the cable spacing which is specified in the project specifications. Each trench must be excavated in a way that half the specified width will be left on both sides of the designated centre line of the cable or group of cables. The trench width must be adequate for the proper compacting of the fill materials when backfilling is done. (In the case of trenches for cable sleeves or –ducts, see sub clause 5.1.1 of SANS 1200 LC).

2.15.5.9 Cleaning of Route

The contractor must clean an area wide enough to ensure that his inspection is not obstructed along the cable trench as specified in SANS 1200 C. In cases where the cable trench falls within a servitude or passageway of specified width, the damage to the vegetation of the named servitude or passageway must be limited.

2.15.6 Backfilling

2.15.6.1 LV Cables

In trenches containing one or more low voltage cables, the approved fill material must be cautiously placed, in layers of 100mm un-compacted depth, throughout the width of the trench and then compacted to a minimum compacted depth of 150mm as specified in PI.5.10.3.

2.15.6.2 HV Cables

In trenches containing one or more high voltage cables the approved fill material must be placed in the trench as specified in PI.5.10.3. Should the project specification require a layer of protective concrete slabs or plastic warning tape, this must cautiously be centred over the high voltage cable after the first layer of approved uncompressed fill material.

2.15.6.3 Compaction

In areas subjected to road traffic and any other such area which is specified in the project specifications the trenches must be refilled in layers of maximum 150mm depth (after compaction) and in case of soil sticking together (clay material) it must be compacted up to 93% of the modified AASHTO-density or in the case of non-sticky soil (sandy material) up to 98% of the modified AASHTO-density.

Machine compaction will not be permitted directly above the cable(s) or sleeve(s) before a layer of 300mm depth fill material has been placed on top of the cable(s) or sleeve(s).

The machine compaction must be conducted in such a way that the forces superimposed on the cable(s) or sleeve(s) does not exceed that superimposed by ordinary pedestrians or light vehicle traffic when the cover is already 1 m deep. If road traffic is involved, the cable(s) must be protected by a cable-way or – sleeve of at least 100mm in diameter, through which the cable(s) can be drawn at any time.

Cable-ways beneath subways must be cast in concrete in a suitable way, if it is required by the project specifications.

2.15.6.4 Cables at Different Depths

In situations where cables are laid at different depths in a common trench, the same procedure for placing and compaction of the approved fill material beneath and on top of the upper cable applies as for the lower cable. In situations where cables have to be laid on top of each other the high voltage cables must be laid under the low voltage cables. (See drawing LC-1 in SANS 1200 LC).

2.15.6.5 Conduct with Respect to Obstructions

In cases where obstructions are encountered during excavation that demands changes to the trench or a special kind of trench, the contractor must have the Engineer's approval to implement such changes before laying the cable(s).

2.15.7 Excavated Material

2.15.7.1 Stacking

The excavated material must be placed along the trench in such a way that it does not obstruct or damage adjacent fences, trees, drains, gate openings and other properties and must be heaped up in such a way

that traffic is not obstructed. Should this not be possible, the material must be removed from site, with the Engineer's approval and brought back later to backfill the trench after the cable(s) has been laid. Surplus material must be removed by the contractor and on the contractor's own expense.

2.15.7.2 Removal of Surplus Material

Surplus material excavated from trenches must be removed from the trenches side or the servitude to a scheduled area within 0,5 km of the source, as nominated.

2.15.8 Admittance to Properties on Cable Routes

Unless otherwise specified in the project specifications, the contractor must (on his own expense) provide owners, inhabitant, and their vehicles with reasonable access to their properties which may be situated adjacent or near the cable route(s).

2.15.9 Jointing Chambers

Jointing chambers must be of approved size in order to make it possible for the cable jointer to work efficient and expeditiously.

Every chamber must be adequately covered to as far as possible to prevent dust and moisture from penetrating and must be equipped with sufficient lighting, draining and ventilation for use during cable jointing.

2.15.10 Transport of Cable Drums

Cable drums must be carefully transported to prevent damage to the cables and to prevent disturbing the cables. Damaged cables will be rejected. Drums may not be off-loaded by simply allowing them to roll off the back of the truck onto the ground. Drums may only be rolled in the direction as indicated by the arrow painted on the drum by the manufacturer. (This will ensure that the correct tension is maintained and prevent the cable from damage later). Every drum may only have one cable length on it. Proper attention must be given to where the drums are to be off-loaded in order to prevent unnecessary moving thereof, eg. At joint locations.

2.15.11 Handling of Drums on Site

Note: It is recommended that a correctly designed spreader must be used to load and unload the drums with a crane.

Every drum must be mounted on jacks or on a cable-drum trailer with a horizontal supporting beam of suitable size and strength to handle the width and weight of the drum. The drum may not be allowed to rotate freely when the cable is rolled off. (Free rotation causes the cable to twist and loosen the windings, which can cause the inside armouring/insulation of the cable to be stretched). The cable must enter the trench from the top of the reel. All cables ends including that left on the drum or in a trench must be sealed to prevent the penetration of moisture into the cable. The free cable end on the drum must be fastened to the side of the drum.

2.15.12 Rollers

Rollers must be used when each cable is laid and must be carefully placed in the trenches to make sure the cable only lies on the rollers when it is pulled in.

2.15.13 Communication

The contractor must ensure good communication between the operators at the pulling end and at the reel end of the cable while laying the cable(s).

2.15.14 Pulling Cable

The cable may be pulled by hand or by a wrench, but the maximum tension in the cable as specified by the manufacturer, may not be exceeded. A cable grip must be used to pull the cable, but if specified by the project specification, a loop connected to the cable cores and sheathing must be used.

A twist connection must be used between the loop and the rope used to pull the cable. In cases where cables have to be drawn around corners, well lubricated skid-plates or special corner rollers must be used.

Skid-plates and rollers must be firmly secured and must be inspected regularly throughout the cable laying process to ensure that they work properly.

2.15.15 Ambient Temperature During Cable Laying

In accordance with the stipulations of 5.19.2, a cable may not be installed at an ambient temperature that:

- a) in the case of paper insulated cables, is lower than 10°C; or
- b) in the case of PVC-insulated cables, is lower than 0°C.

In situation where the ambient temperature is continuously at a low a temperature, the cable may be installed, with the written approval of the Engineer. Special arrangements are made to keep the cable temperature above the minimum temperature specified in 5.19.1 for at least 24 hours before installation.

2.15.16 Cable Bends

No cable bend may have a smaller radius than the minimum radius specified by the cable manufacturer. This radius shall never be less than the radius prescribed by the relevant SANS specification.

2.15.17 Cables Laid in Sleeves, Cable Ways, etc.

Cables laid under roads or railway lines, must be laid through sleeves or cable-ways that are strong enough to withstand the expected shock loads applied by traffic. The laying of cable-ways and sleeves must comply with the applicable requirements of SANS 1200 LB and SANS 1200 LC. After the cable-ways and sleeves had been laid, they must be cleaned thoroughly to remove roughness and sharp edges that can damage the cable. The ends of spare sleeves and cable-ways must be properly sealed and if the project specification requires a pull wire, this must be installed. The position of these sleeves and cable-ways must be identified in the project specifications.

2.15.18 Spacing Between Cables and Other Services

The minimum spacing between electrical cables and other services must be in accordance with the project specifications. In case of trenches used for a number of electrical cables the minimum horizontal free space required to prevent de-rating of the cables, are as follows:

- a) In the case of cables with a conductor size of not more than 70mm: 150mm

- b) In the case of cables with a conductor size of at least 70mm: 250mm

2.15.19 LV Cable Joints

No joints are allowed in distribution cables, except where it is specifically authorised. The low voltage cable in a continuous cable run must be of one size, except where a change in cable size is necessary, in which case the change must be approved by the Engineer.

2.15.20 Marking of Cables

An approved identification plate or label on which the following information is given, must be attached to every high voltage and low voltage cable in every substation, miniature substation and CDU:

- a) the size of the conductors;
- b) the number of phases;
- c) the route ("from" or "to");
- d) the system voltages.

2.15.21 Reinstatement

The reinstatement of areas over cable- and pipe trench excavations must be executed as specified in sub clause 5.9 of SANS 1200 DB.

2.15.22 The Marking and Recording of Cable Routes

If required by the Engineer the cable run must be marked in such a way that the underground position thereof can be traced at any time. In case of straight runs, the cable route markers may be placed at intervals not exceeding 50 m or as specified by the Engineer.

The contractor must measure and indicate on plan all the detail of the installed cable, the position of each cable run, the depth of each cable, as well as all the joints and cable-ways which are installed. The name of the cable jointer and the date on which the joint was made must be indicated on the plans and, if specified by the project specifications, on the cables as well. Drawings of the cable routes "as built" must be supplied immediately by the contractor to the Engineer after the contractor has finished the work covered by the contract.

2.15.23 Tolerances

Degree of accuracy II applies to approved backfill material and the placing thereof.

2.15.24 Tests

2.15.24.1 Density of Bedding and Back Fill Material

The Engineer may demand a density test to determine the grade of density at the bottom layer of the trench and of the approved back fill material. If the density is lower than specified (see 5.10.3) the Engineer may demand the removal of the material, replacing of the bottom layer or the back fill material with the same or other material, and the re- compaction, on the contractor's own expense.

The contractor is responsible for all tests done as a result of the removing and replacing of material.

2.15.24.2 Electrical Tests

Every part of the cable network between CDU's and substations must be tested for electrical continuity and for insulation resistance. Acceptance tests must consist of the following.

a) Phase identification test

A test must be done to determine if the connections between the end points are correct. All cables must be phased out before connected to the switchgear.

b) Insulation resistance test (Low voltage cables)

The resistance of the insulation of every core to earth and to every other core must be determined. These tests must be done with a 2 000V insulation resistance tester on paper and PVC insulated cables.

B2.16 INSTALLATION OF CABLES

2.16.1 General

All cable sleeves manholes and cable markers are to be provided by the contractor unless otherwise specified. Others will provide cable ducts in the floors of buildings unless otherwise specified. Cable run indoors shall be supported on cable trays or cable rack, secured thereto by heavy duty plastic strapping. The cables shall be fixed at intervals not greater than those stipulated in SANS 10142 and shall be spaced sufficiently to avoid de-rating in terms of SANS 10142 – 1. Cables shall be individually fixed so that anyone may be removed from a group without disturbing the others.

Cables installed in trenches shall be installed at a depth of 1000mm below final ground level for LV cables, 1100mm for Intermediate Voltage cables and 1200mm for MV cables. All cable depth measurements shall be made to the top of the cable when laid directly in ground or to the top of the duct or sleeve where these are provided.

The contractor may only deviate from the above depth provided prior authority in writing has been obtained from the Engineer. A yellow PVC cable warning tape with the wording "DANGER" shall be installed above all cables installed in cable trenches.

Every run of cable shall be a single length without joints. Say that where a run exceeds the general drum length of where the length of a run is increased after the cable is delivered on site, a through box will be permitted. Such through boxes shall be so placed as to afford easy access for maintenance and repair; when they are required in underground cable runs the contractor shall provide special cable markers to locate them.

All cable tails shall be provided with either cable lugs or ferrules as may be appropriate. At each sealing end straps-on cable markers shall be fixed, showing clearly and indelibly the number and size of cable cores and the destination of the cable.

2.16.2 Cable routes

Cables shall follow the routes shown on the drawings; the routes shall only be varied with the written permission of the Engineer. Where no routes are defined on the drawings the contractor may select routes to his reasonable preference but shall obtain written approval of them before installing the cables.

The contractor shall, before trenching commences, familiarize himself with the routes and site conditions and the procedure and order of doing the work shall be planned in conjunction with the general construction program for other services and building requirements. The contractor shall acquaint himself with the position of all the existing services such as storm water pipes, water mains, sewer mains, gas pipes, telephone cables, etc. before any excavations are commenced. For this purpose he shall approach the Engineer's representative, the local municipal authority and any other authority which may be involved, in writing.

The Engineer reserves the right to alter any cable route or portion thereof in advance of cable laying. Payment in respect of any additional or wasted work involved shall be at the documented rates. The removal of obstructions along the cable routes shall be subject to the approval of the Engineer.

2.16.3 Trenching

Trenching shall be programmed in advance and the approved program shall not be departed from except with the consent of the Engineer. Trenches shall be as straight as possible and shall be excavated to a depth of 1150mm x 450mm wide for LV cables, to a depth of 1250mm x 450mm wide for Intermediate Voltage cables and to a depth of 1350mm x 450mm wide for MV cables.

The excavation of cable trenches shall form part of the contract works. Prices for trenching shall be based on the following classifications of the ground:

- i) **Hard Rock**
Shall mean rock that can be excavated only by means of explosives or large rock breaking plant, solid slabs and boulders over 1,00 m³ in volume.
- ii) **Soft rock (Machine excavation)**
Shall mean granite, quartzitic sandstone, slate and rock of similar or greater hardness, solid slabs and boulders from 0,03 m³ and up to 1.00 m³ in volume.
- iii) **Hand Pickable Soil**
Shall mean rock that can be loosened by hand pick and include hard shale, compact decomposed shale and boulders from 75 mm in diameter up to 0,03 m³ in volume.

No allowance shall be made for the breaking away of the trench sides, other earth movements or for trenches excavated in excess of the stipulated dimensions, other than as agreed with the Engineer. No guarantee is given or implied that blasting shall not be required, but should this method of removal be necessary and permitted, then the Contractor shall take all responsibility and observe all conditions set forth in Government and Local Authority Regulations.

Power driven mechanical excavators may be used for trenching operations provided that they are not used in close proximity to other plant liable to be damaged by the use of such machinery. They may not be used within the boundaries of live switchyards. The Engineer must in each case approve their use along sections of the route.

The bottom of the trench shall be level and clear and the bottom and sides free from rocks or stones liable to cause damage to the cable. Payment for cable trenching having greater volume than that specified for the purpose will not be considered except where extra excavations are necessary to bypass obstacles such as water pipes, drains, large boulders, etc. In all such instances the amount of the extra excavations shall be agreed upon on site between the Engineer and the Contractor.

The Contractor must take all necessary precautions to safeguard all pipe work, structures, roads, sewage works or other property on the site from any risk of subsidence and damage. The contractor will be held responsible for damage to any existing services brought to his attention by the relevant authorities and shall be responsible for the cost of repairs.

The contractor shall take all the necessary precautions and provide the necessary barriers, warning signs and/or lights to ensure that the public and/or employees on site are not endangered. The contractor shall ensure that the excavations will not endanger existing structures, roads, railways, other site constructions or other property. Trenches shall connect the points shown on the drawings in a straight line. The Engineer beforehand shall approve any deviations due to obstructions or existing services. The bottom of the trench shall be of smooth contour, and shall have no sharp dips or rises, which may cause tensile forces in the cable during back filling.

The excavated material shall be placed adjacent to each trench in such a manner as to prevent nuisance, interference or damage to adjacent drains, gateways, trenches, water furrows, other works, properties or traffic. Where this is not possible the excavated materials shall be removed from site and returned for back filling on completion of cable lying.

Trenches across roads, access ways or footpaths shall not be left open. If cables cannot be laid immediately the contractor shall install temporary "bridges" or cover plates of sufficient strength to accommodate the traffic concerned. In the event of damage to other services or structures during trenching operations the contractor shall immediately notify the Engineer and institute repairs.

Prior to cable laying the trench shall be inspected thoroughly and all objects likely to cause damage to the cables either during or after lying shall be removed. Where ground conditions are likely to reduce maximum current carrying capacities of cables or where the cables are likely to be subjected to chemical or other damage or electrolytic action, the Engineer shall be notified before installing the cables. The Engineer will advise on the course of action to be taken. Extreme care shall be taken not to disturb surveyor's pegs. These pegs shall not be covered with excavated material. If the surveyor's pegs are disturbed, a person qualified to do so shall replace them.

2.16.4 Laying and Installation of Cables

The general installation of cables shall conform with the guidelines contained in the relevant SANS Specification regarding the handling of drums on site and minimum installation bending radius.

2.16.5 Laying of Cables in Ground

When laying cables in trenches excavated in soft or hard rock or containing sharp stones, rocks or other times likely to injure cables, the following precautions shall be taken:

Before laying the cables, all injurious items shall be removed from the bottom of the trench. The floor of the trench shall be evenly covered with a layer of sifted backfill, or sandy loam to a level which is 150 mm above the highest unevenness of the trench. The backfill used for this purpose shall have passed through a screen having a 6 mm square mesh. The thermal resistivity of the bedding soil shall be less than 1.20 K m/W.

The laying of cables shall not be commenced until the trenches have been inspected and approved. The cable shall be removed from the drum in such a way that no twisting, tension or mechanical damage is caused, and must be adequately supported at short intervals during the whole operation.

After the cables have been laid in the trench on 150mm bedding and inspected and approved by the Engineer they shall be covered with an additional 150 mm layer of bedding. The backfill shall be well consolidated. Backfilling shall then be continued with proper grading of material to ensure settling without voids, and the material is to be stamped down after the addition of every 150 mm layer. The surface is to be made good to approval, and in the case of roadway crossings the excavations must be consolidated to original stability. Where cables pass under roadways, they shall be laid in 110mm diameter PVC sleeve provided or in pipes at a depth not less than 1 500 mm below the surface.

Should the specified backfill not be available at any particular section of the trench, the Contractor shall transport from elsewhere. Where cables are cut and are not intended to be made off within 24 hours the ends are to be sealed without delay.

Where more than one horizontal layer of cable is laid, the level of the upper layers of cable shall be gauged from the level of the finished bottom of the trench and marked on the side of the trench at frequent intervals before the installation of the lower layers, to ensure that the correct vertical spacing is maintained.

The contractor shall, before commencing with any excavation work, satisfy himself as to the location of any buried cables, water pipes, buried earthing conductors or other underground service which might be damaged during excavation. Any damage inflicted on other services by the Contractor shall be immediately reported to the engineer and shall be made good by the Contractor or by others at the Contractor's expense. All surplus ground, rocks and spoil generally shall either be removed to a selected area of the site or shall be spread evenly across the surface of the site, whichever is directed by the Engineer, and the cost of same shall be included in the prices for laying and installing the cables.

2.16.6 Bedding

LV, Intermediate, Medium & High voltage Cables: The bottom of the trench shall be filled across the full width with a 150mm layer of soil with a thermal conductivity of at least 1.2 [Watt/°K m] for the bedding of the cables.

After cable laying a further layer of 150mm of the same bedding soil shall be provided to extend to 150mm above the cables.

2.16.7 Backfilling

The contractor shall not commence with the backfilling of trenches without prior notification to the Engineer

so that the cable installation may be inspected. Should the contractor fail to give a timeous notification, the trenches shall be re-opened at the contractor's cost. Such an inspection will not be unreasonably delayed.

For all cables, a coloured plastic-marking tape shall be installed 200mm above the cable. The tape shall be yellow, with red skull and crossbones with the words "ELECTRIC CABLE". These markings shall not be more than 1m apart from center to center. Back filling shall be undertaken with soil suitable to ensure settling without voids. The maximum allowable diameter of stones present in the back fill material is 75mm.

The contractor shall have allowed in his tender for the importation of suitable backfill material if required. The backfill shall be compacted in layers of 150mm and sufficient allowance shall be made for final settlement. The contractor shall maintain the refilled trench at his expense for the duration of the contract. Surplus material shall be removed from site and suitably disposed of. On completion, the surface shall be made good to match the surrounding area.

In the case of roadways or paved areas the excavations shall be consolidated to the original density of the surrounding material and the surface finish reinstated.

2.16.8 Blasting

No guarantee is given or implied that blasting will not be required. Should blasting be necessary and approved by the Engineer, the contractor shall obtain the necessary authority from the relevant Government Departments and Local Authorities. The contractor shall take full responsibility and observe all conditions and regulations set forth by the above authorities.

B2.17 ELECTRICAL MV SUPPLY CABLES

2.17.1 General

Written approval for the use of a mechanical trench digger shall be obtained from the Engineer.

All possible steps shall be taken for the protection of trees, plants, flowers and shrubs during the execution of the contract. Where the cable trench passes through chemically active soil, the Engineer shall be informed accordingly. The Engineer is responsible for the analysis of the soil in a laboratory of and to take the necessary steps for the safety of the cables. If the Engineer is not notified of chemically active soil, the organisation erecting the installation will be held responsible for any damage that may be caused to cables.

Where any obstacle or obstruction is encountered during the erection of the installation which necessitates alterations to the cable trench or cable route or method of construction, such alterations shall first be approved by the Engineer in writing. The alterations shall be indicated on the "as-built" drawings.

Where excavations pass within one meter of strut-, telephone-, electrical-, or traffic light poles it is necessary to carry out tunnel excavations for a distance of 500mm on each side of the relevant service. The tunnel excavation shall be executed as a safety measure for overhead services. The number of cables that have to be laid will determine the width of the tunnel. The height shall be such that the maximum quantity of support soil is retained.

The contractor must do all measuring on site himself in respect of lengths of cable, earth wires and ditches required. The lengths given in the schedules are only allowed for tender purposes. Payments will only be made for the lengths of cable actually installed and at the tendered tariffs. In their tenders, Tenderers must allow for cut-off lengths of cables and bends.

The storage, transport, handling and lying of cables must conform to approved and acceptable practice and must meet the requirements of SANS 10198 as amended. Cables which are cut and left open for a period of time before being coupled must be sealed in the prescribed manner. When such cable ends are flooded by water, they must be subjected to the tests prescribed by the Engineer.

The contractor shall have adequate suitable equipment and labour available to prevent damage to cables. Before the cable is installed, the cable trenches must be carefully inspected and any objects, which may damage the cable during or after installation, must be removed.

2.17.2 Sealing glands for PVC insulated cables

The sealing glands must consist of a sleeve in which a conical bush screws into one side and a nickel-brass or galvanized steel lock nut is situated on the other side. The galvanizing must meet SANS 763 as amended standards. The sleeve must have a hollow groove on the side on which the cable enters the sleeve to house the top ring of the waterproofing mantle.

The waterproofing mantle must be manufactured from non-weathering neoprene or other synthetic rubber and must be proof against water, oil and sunlight. These mantles must fit snugly over the sealing glands and the cables. Sealing glands must have a 150 screw thread and must be suitable for the specified cable sizes.

2.17.3 Cable joints

Cable joints are not permissible except where specifically approved. No joints will be allowed where the specified length of cable appears on a drum.

B2.18 SLEEVES

Cable sleeves shall be provided where shown on the drawings and wherever necessitated by installation conditions. Sleeves shall be of steel water pipe when traversing railways sidings, heavy duty tarmac, loading areas, etc.; they shall be of other approved materials where traffic loading is lighter.

Cable sleeves shall not be less than 100mm internal diameter unless specifically noted otherwise in the Project Specification; they shall be of continuously smooth bore with no snags or hitches en route and shall encompass only easy sweeping bends permitting the easy passage of the heaviest cable involved. No cable sleeve shall exceed ten meters without a manhole draw position, unless authorized in writing by the Engineer.

Cable sleeves entering a floor cable duct shall be swept gently to the level of the bottom of the trench so that cables do not kink at entry to the trench. Cable sleeves brought to switchboards or distribution boards having no associated floor cable ducts, or brought to rising cable ducts shall be swept up easily so that the cable emerges vertically from the floor. In cases where the emerging cable is exposed to view, wooden dams shall be fitted round the cable at the top of the sleeve, and the floor screeded completely round the cable. The outer ends of cable sleeves entering buildings shall, after drawing in the cables, be water proofed with cable compound of low melting point.

Sweeping bends shall be installed where sleeves enter distribution boards. Sharp sleeve bends are not acceptable. Cables attached to external walls must be placed in a recessed galvanized pipe from 300mm below ground level into the meter box or into roof spaces complete with brass bushes at both ends. The ends of all sleeves shall be sealed with a non-hardening watertight compound after the installation of cables. All sleeves intended for future use shall likewise be sealed.

B2.19 CABLE MARKERS

The necessary number of cable markers must be installed so as to indicate the route of underground cables, as on the drawings. Where the direction of cables changes, this must be indicated on the surface by means of cable markers. Cable markers must be concrete pyramids, with measurements of 150mm x 150mm on the top and 250mm x 250mm at the bottom. Their height must be 300mm.

Brass plates must be cast into the tops of these pyramids in such a way that they cannot be removed easily. The words "ELECTRIC CABLE" must be punched onto these plates as well as the voltage of the cable and an arrow indicating the direction of the cable routes. The cable must be linked to the cable marker by a galvanized wire cast in the cable marker.

Cable markers must be placed on the surface above all underground cables and must stand out 35mm above ground level, unless they are a danger to pedestrians or traffic, in which case the tops of the markers must be flush with the level of the ground.

Cable markers must be placed at the beginning and end of each cable route (e.g. where a cable goes into a cable kiosk or a building); at changes of direction; at all joints; above cable sleeve inlets and outlets, and

along the whole cable route at distances not exceeding 50 meters.

B2.20 LABELS AND NOTICES

The contractor shall arrange for the labelling of all equipment, instruments, meters, relays, cables, etc., as indicated below. Where identical items of equipment can be removed from their housings, e.g. HV circuit breaker carriages, plug-in relays etc., both the fixed and withdrawal portion are to be labelled identically. All labels shall be ivory or other back engraved white on black labels of the sizes indicated. They are to be located in purpose made holders or otherwise are to be screwed or riveted into position. "Dymo" tape or similar labels will not be accepted nor will labels, which are glued in position only.

Labels on poles shall comprise an aluminium plate with the designated number. These labels shall be nailed to the pole 1,5m above ground level. Nails shall be electro-galvanized clout nails. Prior to any equipment being labelled, the contractor shall request the Engineer to provide a complete labelling schedule for all items of equipment. Under no circumstances is equipment to be labelled in accordance with the tender drawings since any description thereon is for identification purposed during construction only and is unlikely to apply to the completed Works.

The following list indicates the general labelling requirements but does not limit the extent of labelling required, which shall encompass the full extent of the equipment supplied, or in the case of existing equipment, any such which is affected by this Contract.

50mm high lettering:-

- Substation and mini sub designation.
- Outdoor switch gear designation.
- Transformer designation.
- Distribution kiosk and fused feeder panel designation.

20mm high lettering:-

- Main or sub-main board designation.
- Control panel designation.
- Indoor switch gear designation.

5mm high lettering:-

- Mini sub feeder breakers and isolators.
- Distribution kiosk feeder breakers and isolators.
- General distribution switchgear.

This size shall be used to designate the conductor size and number of cores of each cable installed under this Contract. In addition, all feeder cables shall be labelled at both ends indicating from where/to cables are feeding. All kiosks shall be provided with a label in both official languages reading "In case of leakage or accidental contact, put off main switch immediately". All kiosks shall be provided with notices as required by the Machinery and Occupational Safety Act. All doors to such locations shall be fitted with the appropriate notices.

Where more than one similar item of equipment is fed from the same board or control panel, the item itself shall be labelled, this being fixed in a permanent position, i.e. not attached to motors, pumps, etc., but to bases or adjacent thereto. The lettering shall be 50mm high. Each distribution board shall additionally

bear a label indicating the source and size of the feeder to it. Labelling will be done with "Brother tape".

For example: DB.C (Normal)

Fed from Mini-sub 2
25mm² x 4 core cable + 16mm² BCEW

Each feeder must be labelled at both ends with "Brother tape" and a clear heat shrink to cover the tape. This label must indicate the size of the cable and from/to where the cable is feeding.

For example: 70mm² x 4 core cable + 50mm²
BCEW Fed from DB.A to DB.B

Light switches, socket outlets, multi outlets, pop out boxes and isolators must be labelled indicating from/to which DB and circuit it is feeding.

B2.21 CONDUCTORS

Cables used for wiring the installation must be 1000V grade PVC insulated cables for LV installations, contractor so confirm voltage grades for other voltages. Heat resistant cables must be heatproof PCP insulated (e.g. B.I.C.C. or other approved type). Cables must not be old stock and must be delivered on site with their seals unbroken. PVC insulated conductors must meet SANS 150 and 1507 as amended standards and bear the SANS mark. Conductors for light circuits must be 1,5mm² and those for outlet socket circuits 2,5mm², unless specified otherwise.

Because of the distortion of insulating materials at temperatures above 57°C, PVC cables must not be directly attached to the terminal clamps of equipment such as stoves, geysers, built-in electrical heaters and any other electrical apparatus or equipment (including light accessories) of which the temperature exceeds 57°C.

B2.22 EQUIPMENT OF SWITCHBOARDS AND DISTRIBUTION KIOSKS

The fault-breaking capacity of each breaker shall be certified by IEC test to be not less than the prospective fault levels marked on the wiring schedules. When used as main L.T. switches protecting transformers, they shall be submitted to the Supply Authority for trip testing.

Moulded case circuit-breakers shall comply with IEC 157-1 or SANS 156: 1987 as amended shall be of fixed or draw-out execution as set out in the Project Specification. It shall have fault-breaking capacities certified by I.E.C. test to be equal to or greater than the prospective fault levels marked on the wiring schedules. Wherever possible, circuit breakers shall bear the SANS mark.

Miniature circuit-breakers shall comply with SANS 156: 1987 as amended and shall bear the SANS mark.

The fault-breaking capacity of miniature circuit breakers shall be certified by SANS test to be not less than the values set out in the wiring schedules. Current-limiting circuit breakers, suitably certified, are acceptable in all cases.

In general circuit-breaker overload trip systems of the thermal or hydraulic-magnetic types are equally acceptable. In cases where high ambient temperatures or widely varying extremes of ambient temperature are expected hydraulic-magnetic devices shall be preferred: alternatively thermal devices with ambient temperature compensation may be offered. Where circuit breakers have to sustain motor-starting currents and the like, circuit breakers shall be hydraulic-magnetic with appropriate tripping characteristics. Where described in the Project Specification as being for short-circuit protection only, the circuit breakers shall be supplied without overload trip devices.

Switches shall comply with the requirements of SANS 152: 1987 as amended and shall be capable of safely making onto fault currents of the magnitudes shown on the wiring schedules. Main switches of distribution boards shall additionally comply with the requirements of SANS 152: 1987 applicable to switch-disconnectors. The main switches shall be rated for uninterrupted duty. Other switches shall be rated for 8-hour duty – the utilization category shall in all cases be AC22. All switches and switch-disconnectors shall bear the SANS mark. Contactors shall comply with SANS 1092: 1993 and shall be rated to perform not less than 1 000 000 operations at the current ratings and duties quoted on the wiring schedules. They shall be so fixed as to ensure adequate coil ventilation. Contactors shall comply with the detailed requirements set out later in this Specification.

The internal wiring of switchboards shall be done with colour-coded PVC-insulated stranded conductors and shall include all phase, neutral, earth and control wires between equipment and to terminal blocks. Wiring channels shall be made spacious enough to permit the easy passage of all circuit wiring with adequate spacing between different circuits to promote ventilation. All the wires of each circuit or sub-circuit shall be braided together with approved strapping and shall be so arranged as to permit any individual circuit to be examined or renewed without disturbing any other circuits. Stranded conductors shall be terminated in crimped lugs of ferrules; manual crimping shall be done with makers' special tools which will not release until the full crimping pressure has been achieved; the ends of conductors from 50mm² cross-sectional areas upwards shall be crimped by hydraulic machine.

All labels shall be of plastic "sandwich board" material, the legends being engraved through the front plastic layer to the contrasting inner layer. The lettering of legends shall not be less than 6mm high in sans-serif capitals; white lettering on black ground or black lettering on white ground shall be selected as necessary to ensure maximum legibility and contrast with the switchboard finish. All labels shall be secured by at least two bolts or rivets per label and shall be accurately level and central over their subjects.

Bus bars shall be of copper or aluminium and shall comply with SANS 1195: 1978. Copper bus bars shall be tinned after fabrication; the current ratings shall be those assigned by the Copper Development Association. Aluminium bus bars shall be of bright finish; the current ratings shall be those assigned by Alcan Aluminium S.A. Ltd. Multiple bars shall be arranged with air gaps between the sections, equal to the section thickness. Insulating busbar supports shall be provided at intervals related to the prospective short-circuit fault currents, the following table being a guide for single-section bus bars:

Busbar Section mm x mm	kA at 400V for Insulating Spacing of			
	450mm	450mm	450mm	450mm
25 x 9,5	29	21	17	14
40 x 9,5	47	35	27	23
50 x 9,5	55	47	39	33
75 x 9,5	61	53	47	43

100 x 9,5	67	58	52	47
-----------	----	----	----	----

Cable sealing ends and glands shall be fixed to perforate metal gland plates or racks rigidly fixed in the boards and so positioned that terminating the cables is made easy.

B2.23 COMPLIANT LUMINAIRES & SIMULATION REPORTS

2.23.1 Luminaires identification

Luminaires shall conform to SANS 10098-1 & -2 or IEC equivalent and shall bear the SANS 60598-2-3 and SANS 60598-2-5 safety mark or equivalent International rating. Lighting outlets are numbered on the drawings. The numbering of the outlets defines the circuitry and control required. Each luminaire shall be furnished with the wattage and colour as specified or as implied by the supplier of the luminaires specified.

Note to Tenderer:

Only LED luminaires will be accepted for the tender and a letter submitted indicating the origin from which luminaires are imported / manufactured from. The lighting simulation reports submitted are to indicate compliance to SANS 10098-1 & SANS 10098-2 standards or IEC equivalent. Lighting simulation reports are to be submitted in both hard copy and PDF format and simulations are to be submitted in DIALux Version 4.12 or later format compatibility. The PDF simulation reports and DLX format simulations are to be submitted on the tender submission CD, under sub folder LIGHTING SIMULATIONS.

Failure to submit the simulation reports, DLX simulations and valid readable luminaire photometric files (IES format or equivalent) with certification letters from a reputable test facility (SABS, CSIR test facilities or similar) shall render the tender non-responsive. Tenderers are urged to use standard spigot lengths and rake angles, where a favourable lighting design uses a fixed spigot length and fixed rake angle for all simulations, thus minimising maintenance costs. Tenderers may be requested to submit samples of their proposed luminaires to the engineer to verify compliance of the luminaires. Tests to be conducted, but not limited to, include verifying the photometric file to the actual luminaire, IP rating, metallurgical testing, operation at rated ambient temperature, etc. The luminaires shall be returned to the tenderers by the engineer.

The Tenderer shall provide four (4) simulation reports, forming a complete set of lighting simulations, that comply with the lighting designs as described below, which as a whole is compliant to the SANS 10098-1:2007 & SANS 10098-2:2005 or equivalent IEC standards.

If there is any discrepancy between B2.23 and SANS 10098- 1:2007 & SANS 10098-2:2005, SANS 10098-1:2007 & SANS 10098-2:2005 will be the standard to be adhered to.

The evaluation of simulations will be based on SANS 10098-1 & SANS 10098-2 or IEC equivalent standards and evaluated with the DIALux lighting simulation software, version 4.12 or later. Simulation results shall be to two decimal point accuracy. Should a lighting simulation out of the entire lighting simulation set be non-compliant or should there be discrepancies, it may render the tender non-responsive.

Refer to the electrical and civil drawings for cross section designs of the roads, underpass, pedestrian

bridge and light pole placement. Drawings included on tender CD. The correction factor, which can be used in DIALux to alter a luminaire's performance, will be set to be equal to 1 for all luminaires used in the lighting simulations. Luminaires selected are to adhere to tender specifications. Where the same luminaire type is used in several lighting simulations, the luminaire type must be compliant in all lighting simulations. Spigot length excludes the mounting length of the luminaire.

The correct surfaces are to be used in the lighting simulations, e.g. brick paving for sidewalk and R3, q0 0.070 tarmac for carriageway surfaces, etc. Emergency lanes (also referred to as shoulder lanes) are to be included in the lighting simulations and shall comply to the lighting levels specified for each respective simulation specified in table B2.23.2 below.

Colour rendering, colour temperature, is to remain constant for entire luminaire selection. It may only vary between road lighting and pedestrian sidewalk lighting. Example: using luminaires with a colour temperature of 2000K for road lighting and luminaires with a colour temperature of 4000K for pedestrian sidewalk lighting.

Each simulation is to comply with the corresponding simulation design criteria in Tables B2.23 below and the corresponding simulation design criteria drawings which follow. Luminaire maintenance factors are to be stated and calculated below and used accordingly in the simulations. The dirt depreciation factor is obtained from SANS 10098-1 Table B.1 for a burning period of 36 months before cleaning of an IP6X luminaire in an average environment installation.

Luminaire Maintenance Factors Table - Form B2.23.1

Luminaire Type	Luminaire description	Dirt Depreciation Factor	Lamp / LED Depreciation Factor for Ta = 35°C (LLMF*LSF*LMF) As per CIE 154:2003	Maintenance Factor
A	B	C	D	E = (CxD)
L1		0.83		
L2		0.83		

Lighting Simulation Design Criteria – Form B2.23.2

Simulation	Luminaire Type	Pole Spacing [m]	Pole Mounting Height (MH) [m]	Mast above Road Level [m]	Spigot Length [mm]	Maximum Rake Angle [degrees]	Offset from Edge of Road	SANS 10098 Lighting Category
1	L1		10.50m MH	0.00	500	15	0.50 m	Ln ≥ 1.50 cd/m ² U ₀ ≥ 0,40 U _L ≥ 0,70 TI ≤ 20

2	L2		6m MH	0.00	≥125	15	2.88m	$L_n \geq 1.50$ cd/m^2 $UO \geq 0,40$ $UL \geq 0,70$ $TI \leq 20$
3	L1-L2		10.50m MH+8m MH	0.00		15	0.50 m	$L_n \geq 1.50$ cd/m^2 $UO \geq 0,40$ $UL \geq 0,70$ $TI \leq 20$
4	L1		10.5m MH	0.00		15	2.25 m	$L_n \geq 1.50$ cd/m^2 $UO \geq 0,40$ $UL \geq 0,70$ $TI \leq 20$

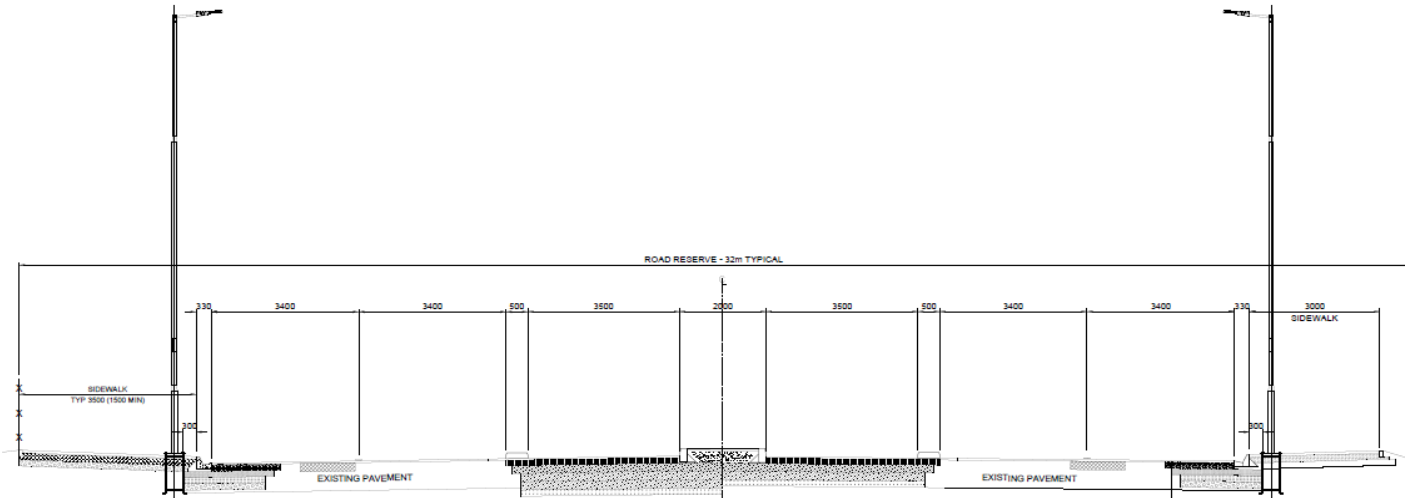

Simulation 1 - Type L1 Luminaire

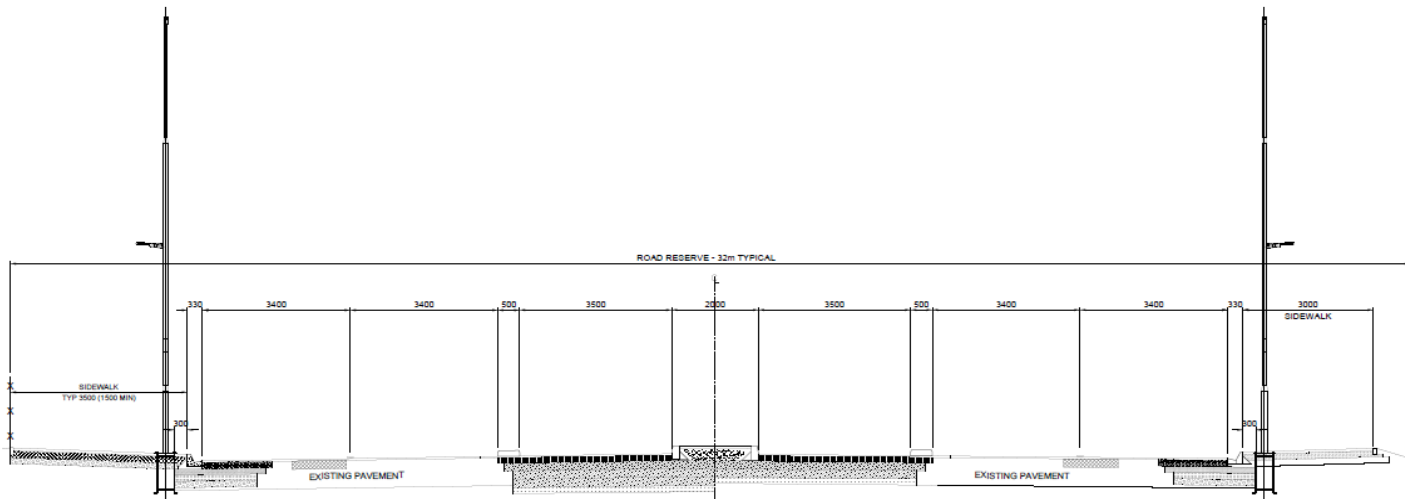

Simulation 2 - Type L2 Luminaire

Contract: RTD 04 2023/24 Integrated Rapid Public Transport Network (IRPTN) Project:
UPGRADING OF IRPTN LINE 3 INTERIM OPERATIONS: PRINCE'S PARK AVENUE AND BUS STOPS/BAYS ALONG WF NKOMO STREET
Part C3: Scope of Works

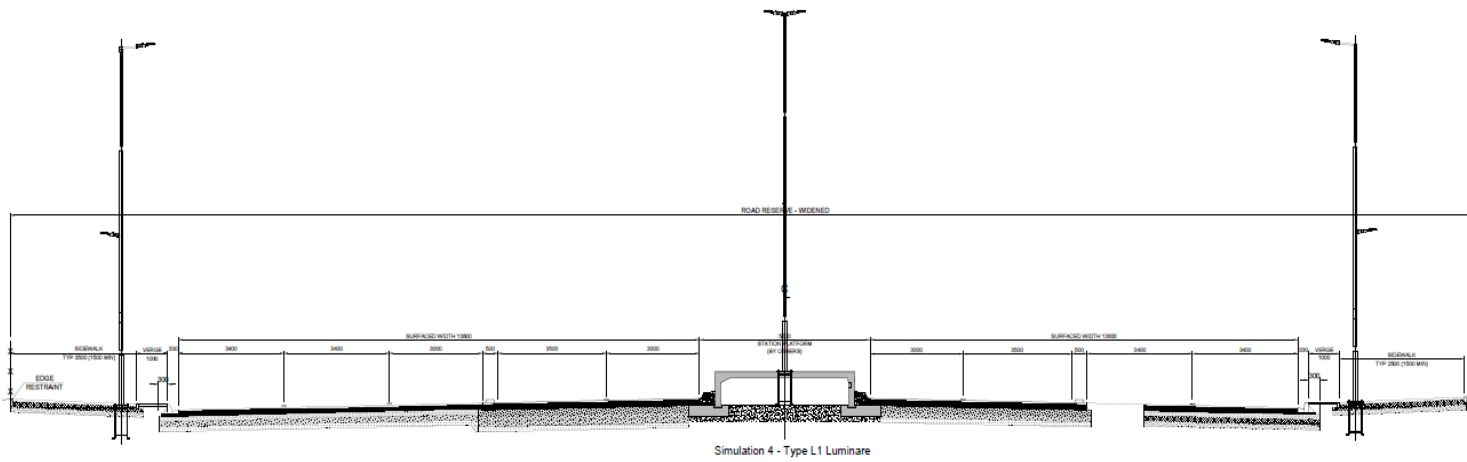
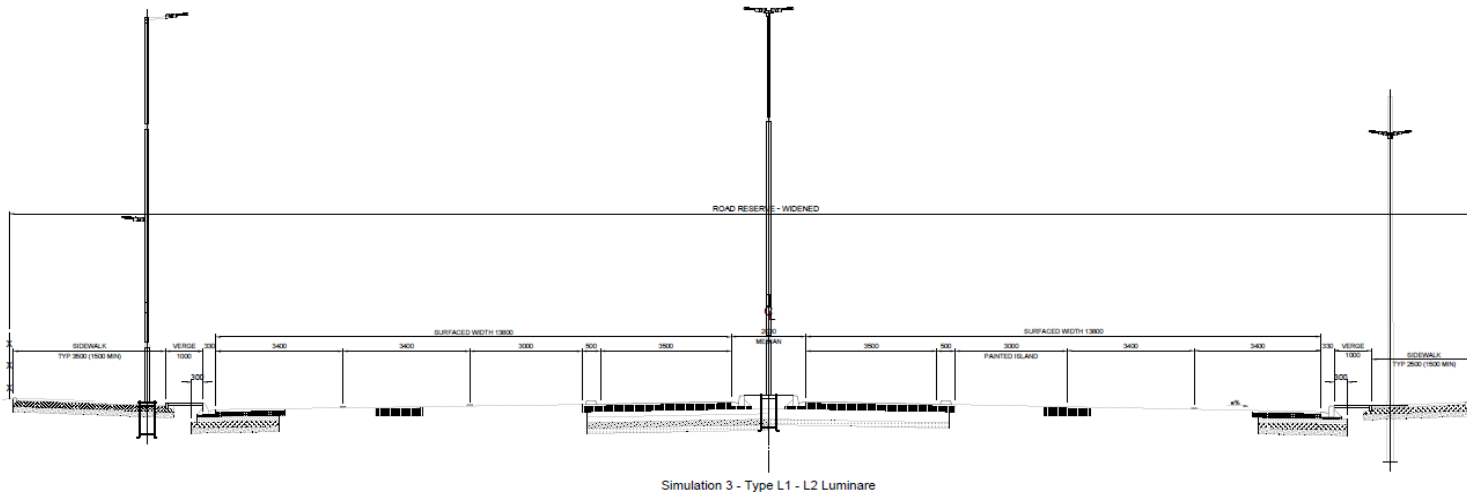

B2.24 LUMINAIRE AND LED MODULE LIFESPAN

Note to Tenderer:

Should the information that is submitted for B2.24 be incomplete or vary from the information submitted for B2.23, particularly with respect to the simulation results, it may render the appointment of the electrical sub-contractor non-responsive. The Tenderer must provide a letter from the supplier on the following for each type of luminaire (Failure to submit all documentation as requested below may render the tender non-responsive):

1. Specify the rated Thermal threshold of the Luminaire and Lamp / LED module.
2. Luminaire and LED module lifespan in hours at rated operating ambient temperature, $T_a = 35^{\circ}\text{C}$.
3. Luminaire lumen output efficiency over the lifespan at $T_a = 35^{\circ}\text{C}$.
4. Lumen degradation over life span, rated for $T_a = 35^{\circ}\text{C}$.
5. Control Gear and components lifespan, rated for $T_a = 35^{\circ}\text{C}$.
6. Reputable Certificate (from SABS, CSIR testing facility or similar) stating that each Luminaire offered has an aluminium housing of marine grade (EN1706 AC-44100) (or higher) aluminium alloy and complies with BS 1490.
7. Certificate (from SABS, CSIR testing facility or similar) stating that the IP Rating and Thermal dissipation of the luminaire is unchanged by the inclusion of an energy/monitoring control gear system within the luminaire and a circuit breaker.
8. Control Gear and components lifespan due to the inclusion of the energy/monitoring control gear system. Certificates from the Regulator, the body appointed by the Minister to administer compulsory specifications, are to be submitted for all luminaires proposed, in which the luminaire and all components of the luminaire adhere to the relevant Gazetted compulsory specifications. These certificates verify that any imported material adheres to Gazetted compulsory specifications and are allowed to be imported and used in the country. Failure to submit these certificates will render the tender non-responsive.

Note to Tenderer:

(b) Energy Costs (Average R/kVAh is estimated @ 10% increase per year over a 15 year life cycle)

Energy Cost Table Form B2.24.2

Luminair e Type	LUMINIAIRE DESCRIPTION	UNI T	QTY	RATE	AMOUNT	Luminaire Lumens [lm]	Rated Luminai re Wattage [kW]	Power Factor	Total Power per Luminaire [kVA]	Avera ge Burni ng Hrs/A n num	Averag e R/kVAh over 15 years	Life Cycle	Energy cost per life cycle
1	2	3	4	5	6 = 4 x 5	7	8	9	10 = 8 / 9	11	12	13	14 = 4 x 10 x 11 x 12 x 13
Type 1		No		R	R					3650	R 2.46	15	R
Type 2		No		R	R					3650	R 2.46	15	R
TOTAL INITIAL LUMINAIRE INSTALLATION COST				SUM A	R	TOTAL ESTIMATED ENERGY COST OVER LIFE CYCLE PERIOD					SUM B	R	

Maintenance Cost Table Form B2.24.3

Luminaire Type	Luminaire Description	Unit	Qty	Cost of Lamp / "LED Module" per Luminaire	Cost of Ballast/ Electronic Driver	Rated average Lamp / "LED Module" Life at Ta = 35°C	Rated average Ballast / Electronic Driver Life at Ta = 35°C	Average Burning Hrs/Annun	Annual Lamp / "LED Module" Replacement	Annual Ballast / Electronic Driver Replacement	Life Cycle	Maintenance cost per life cycle
1	2	3	4	5	6	7	8	9	10 = 9 / 7	11 = 9 / 8	12	13 = 12 x 3 x [10(5) + 11(6)]
Type 1		No		R	R			3650			15	R
Type 2		No		R	R			3650			15	R
TOTAL ESTIMATED MAINTENANCE COST OVER LIFE CYCLE PERIOD										SUM C	R	

B2.25 LIGHTING DESIGN LIFE CYCLE COST

Note to Tenderer:

The information provided by the suppliers, for the three tables as requested below, shall be used by the evaluation panel to determine the life cycle cost over a fifteen-year period. The total for maintenance shall be added to the total for energy consumption. These forms may be used as a determining factor in the final evaluation of the appointment of the electrical subcontractor. Should the best life cycle cost not be from the lowest offer (price and preference) then the difference between the lowest offer and the offer being considered shall be compared to the best savings offered in B2.25 of the tender being considered, if deemed necessary.

Maintenance and Energy Costs are to be shown for the entire lighting installation for all luminaires, without the use of an energy management and monitoring control system. The tables below are included on the tender CD in Excel format that are to be completed, signed hard and soft copies submitted and the electronic Excel format copy completed and submitted.

**LIFE CYCLE COST SUMMARY OF LUMINAIRES FOR
 Installation Table Form B2.25.1**

No	Description (Note: Life Cycle based on a 15-year period⁰)	Amount s
1	SUM A - Initial Capital Cost of Luminaires for Installation	R
2	SUM B - Estimated Energy Consumption Cost of Luminaires for Installation	R R
3	SUM C - Estimated Maintenance Cost of Luminaires for Installation	
	TOTAL EXCL. VAT (1 + 2 + 3)	R

Note to Tenderer:

(a) Energy Costs (Average R/kVAh is estimated @ 10% increase per year over a 15 year life cycle)

Energy Cost Table Form B2.25.2

Luminaire Type	LUMINAIRE DESCRIPTION	UNIT	QTY	RATE	AMOUNT	Luminaire Lumens [lm]	Rated Luminaire Wattage [kW]	Power Factor	Total Power per Luminaire [kVA]	Average Burning Hrs/Annum	Average R/kVAh over 15 years	Life Cycle	Energy cost per life cycle
1	2	3	4	5	6 = 4 x 5	7	8	9	10 = 8 / 9	11	12	13	14 = 4 x 10 x 11 x 12 x 13
Type 1		No		R	R					3650	R 2.46	15	R
Type 2		No		R	R					3650	R 2.46	15	R
TOTAL INITIAL LUMINAIRE INSTALLATION COST				SUM A	R	TOTAL ESTIMATED ENERGY COST OVER LIFE CYCLE PERIOD					SUM B	R	

Maintenance Cost Table Form B.25.3

Luminaire Type	LUMINAIRE DESCRIPTION	UNIT	QTY	Cost of Lamp / "LED Module" per Luminaire	Cost of Ballast/ Electronic Driver	Rated average Lamp / "LED Module" Life at Ta = 35oC	Rated average Ballast / Electronic Driver Life at Ta = 35oC	Average Burning Hrs/Annun	Annual Lamp / "LED Module" Replacement	Annual Ballast / Electronic Driver Replacement	Life Cycle	Maintenance cost per life cycle
1	2	3	4	5	6	7	8	9	10 = 9 / 7	11 = 9 / 8	12	13 = 12 x 3 x [10(5) + 11(6)]
Type 1		No		R	R			3650			15	R
Type 2,		No		R	R			3650			15	R
TOTAL ESTIMATED MAINTENANCE COST OVER LIFE CYCLE PERIOD											SU M C	R

B2.26 LIGHTING ENERGY MANAGEMENT AND CONTROL SYSTEM

2.26.1 Notes to Tenderer

The Tenderer must provide the following from the supplier (Failure to submit all documentation as requested below may render the tender non-responsive):

1. Proposal of an energy efficient, energy management and monitoring control system with brochure.
2. Product lifespan at rated operating ambient temperature, $T_a = 35^{\circ}\text{C}$.
3. Initial Capital Cost and yearly maintenance cost, inclusive of annual software fees and yearly training, for the entire lighting installation.
4. Separately indicate the yearly energy savings & maintenance cost saving the system could provide by controlling and monitoring the entire lighting installation.
5. Based on an average 10-hour operation period, the minimum energy consumption and saving control of the luminaires will be based on operating at rated power upon nightfall for a period of 2.5 hours, then be dimmed to 50% rated power for 6 hours, before switching to rated power for 1.5 hours before sunrise and switching off. Rated power operation of the luminaires is based on providing the SANS 10098-1 & -2 lighting standard requirements for peak traffic volumes.
6. The energy consumption per year of the energy management and monitoring control system.
7. State whether the energy management and monitoring control system is compatible with the proposed luminaires and that the IP rating of the luminaires will remain intact.
8. State on a letterhead how the energy management and monitoring control system is:
 - vandal resistant,
 - level of security and encrypted software,
 - Degree of adequate redundancies implemented so as to prevent loss of communication with the luminaire controllers.
 - Ability and time period in which to detect and notify if there is a power failure or cable fault due to possible theft.
 - Whether the system has internal back-up power supplies to record and notify of a power loss and period over which data can be record if communication is lost.
 - Form of communication, communication speed and event detection speed

2.26.2 Design Parameters

- a) It is a requirement that a computer based integrated automatic lighting energy management, monitoring and control system is provided as part of the installations, utilizing the latest GSM networks, fibre-optic networks and wireless technology.
- b) The lighting energy management, monitoring and control system should provide automatic switching and dimming of the following:
 - i) Individual luminaires
 - ii) Group based luminaires
 - iii) Weekday scheduled switching
 - iv) Week-end scheduled switching
 - v) And be able to be customized for Custom Days i.e. Special events and/or special functions in the vicinity of groups of luminaires
 - vi) Dimming should have a number of pre-set levels
- c) It should be possible for an authorized operator to over-ride the above scheduled programs for switching and dimming for individual luminaires, single street level groups, multiple street level

groups and suburb/city level groups.

d) System Monitoring and Data Capturing

Each luminaire should be individually monitored for the following:

- i) Luminaire load
- ii) Last switch on
- iii) Last switch off
- iv) Luminaire voltage
- v) Luminaire current
- vi) Luminaire Power Factor
- vii) Luminaire Power Consumption kWh
- viii) Luminaire dimming status
- ix) Power status
- x) Luminaire Burning Hours, maintenance indication

e) Failure Reports

Failure reports that should generate maintenance schedules for maintenance staff to undertake repairs logged. In addition, circuit phase failure and primary supply failure should be monitored and reported. Utilizing the above the System Operator should be able to alter switching times and dimming schedules in consideration of prevailing weather conditions, thus improving road safety levels along the routes.

All repairs and failures can be monitored to ensure quick notification with exact location for maintenance staff to undertake speedy repairs. Recurring failures can be accurately logged, and this will result in a more comprehensive investigation of the causes. Energy savings can be achieved via improved operation for the particular circumstances on individual roadways.

2.26.3 Power Supply Units

The power supply unit shall have the following features:

- a) The power factor shall be rated at ≥ 0.95 .
- b) The power supply shall be removable and shall be suitable for operation with the specified rating of the lamp on a 185-265VAC 50Hz single phase system.
- c) Operating temperatures shall be from -15°C to $+75^{\circ}\text{C}$ on the housing (case temperature).
- d) Operating humidity shall be from 20% to 95%.
- e) The control gear shall incorporate a thermal switch for protection when exceeding the case temperature.
- f) Provisions shall be made to withstand surges up to 20kV/20kA.
- g) The unit shall be EMC compliant to the EN55015 and EN61347-1 standard.

2.26.4 Contractual Requirements

The following points are required for the contractor/s to adhere to for lighting energy management, monitoring and control system installation instructions and procedures:

- a) The Client will be provided with all necessary training, documentation, manuals, material (including desktop computer, server, etc), and one year licence fee paid after project handover such that the

Client can easily operate and maintain the system.

- b) The integrator must be provided with complete marked-up drawings, showing the installed positions of the luminaires (GPS co-ordinates) and pole numbering prior to project initiation. Electrical Circuits and phases connecting each luminaire, per pole shall be shown. Any changes which affect the drawings, in respect of as-built changes, must be reported to the Integrator within the shortest time possible.
- c) A project kick-off meeting will be required, between the contractors, professional team and the Integrator, to formalise all required information and parameters, in order to ensure successful implementation.
- d) The numbering designations for the poles and luminaires shall be pre-allocated by the Integrator and shall be reflected directly within the lighting energy management, monitoring and control system.
- e) The required IT infrastructure and inter-device connectivity must be provided for before any configuration or commissioning can commence, including interconnectivity between all devices.
- f) The contractor is required to install the luminaires strictly in accordance with the installation procedures, as required for a managed installation. This includes the completion of an installation reference sheet with the following information:
 - Pole number
 - Luminaire number (as labelled by the supplier)
 - Luminaire's device address
 - GPS co-ordinates
 - Circuit number

The above information is to be provided on a daily basis during the construction, immediately after each luminaire is installed. The installation reference sheets must be returned to the Integrators' Field Application Engineer. The responsibility of this shall rest on the contractor to ensure that the provided information is correct. This is critical for the correct identification of each individual luminaire for lighting energy management, monitoring and control system. Failure to follow the provided installation procedures and instructions shall require the contractor to revisit the affected luminaires and/or the entire section at their own cost.

The contractor shall install the lighting energy management, monitoring and control system, in conjunction with and under the direction of the Integrator, in accordance with the installation procedures. The contractor shall also provide support to the Integrator for access to the lighting energy management, monitoring and control system when required.

Upon completion of the electrical works, a 30 day full load fault free test period of the entire electrical system will be conducted, after which a 30 day fault free test period will be conducted of the entire electrical system with the lighting energy management, monitoring and control system implemented during which time any and all faults will be logged and rectified until the system operates for a 30 day fault free test period.

B2.27 PHOTO- ELECTRIC SWITCHES

This unit must consist of a photocell, thermal starter and switch. The body of this unit must be manufactured from strong material to protect it against tampering, and it must also have good anti-

weathering features; it must be capable of withstanding ultra-violet rays and long periods of exposure to the sun. The unit must be a wall/pole-mountable type and it must be fitted with a suitable mounting frame. The unit must be mounted over a 60mm (diameter) round draw-box of which the lid must be fitted with a grommet to protect conductors entering the draw-box. The unit must be installed in such a way that it is not activated by ambient or any other artificial light source. The photocell shall be installed on the first light from a miniature substation or kiosk.

The unit must be pre-set in the factory so that it will switch on at an illumination level of approximately 54 Lux and switch off again at 108 Lux. A time delay of at least 15 seconds must be provided for to prevent the switch from being activated by lightning or other brief changes in the illumination level.

B2.22 ITS AND TELECOMMUNICATION SERVICES

A specialised sub-contractor may be required to fulfil the works. Specifications, drawings, and test procedures will be submitted during the construction phase and will form part of this document.

SECTION B3: PARTICULAR SPECIFICATION

B3.1 MEASURING AND PAYMENT

PRINCIPLES

3.1.1. The basic principles of measurement and payment for cable trench excavations is that the rate tendered for excavations covers the cost of excavations, the re-use of excavated material for back filling and the removal of all surplus material along the trench routes within 0,5 km from the source.

3.1.2. The rate for the laying of the cable covers the cost of the handling and placing of the cable in the approved trench, as well as any other costs concerning the laying of the cables.

3.1.3. Trench excavations for cables, etc. is measured volume wise, but can be measured according to length.

Except when differently stated in the project specification or differently demanded, the depth will be measured from the ground level, along the centre line of the trench, down to the bottom of the specified bottom layer. The ground level is that which was formed after mass ground works was completed, measuring the excavated level or the backfilled level, except where another execution sequence is demanded.

3.1.4. The source of the approved back fill material and the bottom layer is the contractors own responsibility. He is free to use approved material excavated from the side of the trench or other excavations on site, providing such material meets the applicable requirements. He is also free to buy one or both the materials from commercial sources and to excavate along the cable route at his own cost. Additional and separate payment for the backfill of over-excavations and the removal of surplus materials or any other unforeseen works will only be made if such works was specified by the Engineer.

3.1.5. The requirements of sub clause 8.3.3 of SANS 1200 DA apply to additional transport distances. All additional distances will be measured only via the shortest route possible and only in one direction to the nearest 0,1 km measured and the volumes will be calculated as specified in 8.2.3.

3.1.6. All rates shall allow for fault finding and commissioning procedures as well as include making, aiming, conveying, importing, delivering, unloading, storing, unpacking, hoisting, setting, fitting and fixing in position, cutting and waste, plant, temporary works and profit. All equipment and materials shall be new.

3.1.7. The rates shall include all permanent labelling and numbering on all switchgear, cables and equipment. The labelling shall be made from Trafolite (black writing on white background) as detailed in the general technical specification. All ends of cables shall be labelled.

3.1.8. The Contractor shall be responsible for obtaining the Engineer's signature accepting any measurements and payment claims by no later than one week before the payment claim is to be submitted for payment.

3.1.9. Payment for Materials on Site (MOS), with written Engineer approval, may be claimed for billed items purchased by the contractor and stored securely on site, provided the contractor submit delivery notes of material on site and invoices for the materials supplied by the suppliers. The contractor may only claim 90% of the full invoiced amount of MOS submitted by the supplier, provided that the total claimed MOS for each billed item does not exceed 90% of the full amount allowed for each billed item in the pricing schedule.

Although MOS may be claimed, the MOS will remain the contractor's responsibility until project completion and hand-over to the Employer, thereafter the defect liability period is effective, thus any damage, vandalism, theft, etc of materials will be the contractor's responsibility to replace and repair at the contractor's own expense.

B3.2 CALCULATION OF QUANTITIES

- 3.2.1. The length used for calculations is the total length of the cable, cable trench, etc from one end to the other or from one structure face to the next structure face. No deductions will be made for any manholes, etc. Excavations will be measured as if excavated with vertical sides, regardless of whether it was excavated with sloping sides.
- 3.2.2. If volumetric measurements are required, the volume will be measured from the depths shown on the drawings or to the bottom of the specified base, whichever is the largest, and a minimum base width of 450mm in the case of high voltage cables and 350mm in the case of low voltage cables.
- 3.2.3. The volume of the backfill will be calculated from the minimum base width of the trench and the depth of the backfill needed. No allowance shall be made for loss of volume of the compacted material.
- 3.2.4. Imported material must be disposed of along the cable servitude within a distance of 50m from the source unless specified otherwise by the project specifications. Additional transport of material if ordered must be handled as specified in sub clause 8.3.3.4 of SANS 1200 DB. Free haul as specified in sub clause 5.2.6.1 of SANS 1200 DA shall be applied.
- 3.2.5. If supports are specified or ordered, the length of the supports will be measured for payment along the centre of the trench. This tariff includes works done as specified in 8.3.1.4(a) of SANS 1200.

B3.3 SCHEDULED ITEMS

B3.3.1 GENERAL ITEMS: ELECTRICAL – SECTION C2.2.1

- 1.1. Insurance of works. Unit: Sum
- The unit of measure shall be for the cost of insuring the electrical works to an amount of 100% of the electrical contract amount.
- 1.2. 3rd Party Insurance. Unit: Sum
- The unit of measure shall be for the cost of providing 3rd party insurance for the electrical works for the duration of the project.
- 1.3 CAD preparation of 'As Built' drawings. Unit: Sum
- The unit of measure shall be for the cost of providing four copies of complete 'as built' drawings on paper and electronically of all equipment, layouts, etc. A suitable CAD package shall be used for the drawings. Exact positions of cables and all electrical services installed shall be clearly shown.
- Included in the rate is the provision of 4 handing over files with all necessary handing over documentation: CoC's test measurements of earthing, loads, currents, voltage drop, as-built drawings, brochures and drawings of all material used in the project (e.g. luminaires, Kiosks, poles, etc.) as well as any keys or maintenance equipment that may be required to be handed over.
- 1.4 Security. Unit: Month
- The unit of measure shall be for the cost of providing Security per month for the electrical works against vandalism and theft for the entire contract duration period defined.
- 1.5 Soil resistivity survey. Unit: Sum
- The unit of measure shall be for the cost of conducting a complete soil resistivity survey for the area. Resistivity measurements shall be taken at, at least 5 locations and at the 11kV supply points. It shall include a certificate and recommendation regarding the soil conditions.
- 1.6 Testing and Commissioning of each Kiosk complete Electrical Installation. Unit: No
- The unit of measure shall be the number of CoC's submitted and approved with 3 hard copies for each metering kiosk, LV kiosk that is energised with electrical circuit installations fully completed and tested and all necessary test results and test certificates submitted. In addition, all testing is to be included in the rate, which will include cable pressure and insulation testing, voltage drop, full load, fault level, loop impedance and earth testing.
- 1.7 Issuing of Certificate of Compliance for the complete Electrical Installation. Unit: Sum
- The unit of measure shall be the number of CoC's submitted and approved with 3 hard copies for each metering kiosk, LV kiosk that is energised with electrical circuit installations fully completed and tested.
- 1.8 Electrical Connection Fee for the Power Supplies. Unit: Prov Sum

The unit of measure shall be a Provisional sum for the application and payment for the power supplies discussed and obtained with the Local Supply Authority. May only claim amount invoiced by Local Supply Authority with 5% handling fee, once payment is made to Local Supply Authority and proof of payment is submitted with claim. In addition submitting CoC's, Connection & service connection fee, terminations, feeder cable testing, appropriately sized feeder circuit breaker (10kA, 400V) and all other provision of supply requirements are to be included in the rate.

1.9 OHS Services. Unit: Month

The unit of measure shall be for the cost of implementing and adhering to all required OHS regulations on site per month.

1.10 Environmental Management Plan. Unit: Month

The unit of measure shall be for the cost of implementing and adhering to environmental management plan on site per month.

B3.3.2 RETICULATION SYSTEM – SECTION C2.2.2

2.1 12 Way LV Kiosk Unit: No.

The unit of measure shall be the number of kiosks supplied, installed, and commissioned.

The rate shall include all associated costs involved in bringing the kiosk to full operational status, including the shaping of the ground level for water to flow away from the kiosk and to allow safe maintenance. Labelling is inclusive in the rate.

A concrete plinth suitable for the kiosk shall be included in the rate. The kiosk shall be painted olive green colour, H05 SANS 1091 specification, and shall be powder coated at the factory, with IP65 rating. The kiosk shall be constructed in accordance with the local municipality specifications.

In the LV compartment, rails shall be mounted to accommodate the control gear listed below in addition to a 20% future allowance. LV circuit breakers are measured within this rate. In addition, included in this rate is the following gear:

- 200A, 415V, three pole, on-load isolator (rated for inductive loads)
- 150A, 415V, three pole, on-load isolator (rated for inductive loads)
- 2x60A, 415V, three pole, on-load isolator (rated for inductive loads)
- 2x25A, 415V, three pole, on-load isolator (rated for inductive loads)
- 4xPolyphase kWh Ferraris, Electro - Mechanical 40-100 A; type E1000GPM or equivalent
- 3xSinglephase kWh Ferraris, Electro - Mechanical 40-100 A; type E1000GPM or equivalent
- 80A, 10kA, 415V curve 1 (slow) three pole circuit breaker to protect kiosk control gear
- 65kA 4-Pole Surge Arrestors
- 100A, 415V three pole contactor (rated for inductive loads)
- 2x50A, 10kA, 400V curve 1 (slow) three pole circuit breaker to protect electrical circuits

- 1x15A, 10kA, 400V curve 1 (slow) three pole circuit breaker to protect electrical circuits
- 4x20A, 5kA, 400V curve 1 (slow) three pole circuit breaker to protect lighting circuits

- 3x20A, 5kA, 230V curve 1 (slow) single pole circuit breaker to protect traffic signals circuits
- 3x10A, 5kA, 230V curve 1 (slow) single pole circuit breaker to protect electrical circuits
- Photocell to control the contactor (switch on at ambient illuminance of 70 lux). Photocell failure shall result in an 'on' state. Similar to that of a Royce Thompson photocell. To be housed within the Kiosk
- Bypass switch to bypass the photocell
- Council Specified Ripple Relay
- 5A, 5kA, 230V, curve 1 (slow) single pole circuit breaker to protect the photocell and contactor.

The LV Kiosk doors shall be fitted with key-alike Union/Yale or similar locks and shall have key facilities for the LV Kiosks. Two individual keys shall be provided with each lock and four master keys shall be provided for the entire installation. *All LV Kiosk doors shall be equipped with a covered, tamper free, vermin resistant, lock system for padlock that cannot be cut by a bolt cutter.*

Implementation and installation of luminaire energy management and monitoring control system section controller inside the LV compartment of mini-sub will remove the contactor, 5A circuit breaker, bypass switch, photocell and delay-on timer (ripple relay). The LV kiosk is to adhere to document specifications and local supply authority specifications. One sample of the complete kiosk shall be available in the factory for inspection by the engineer prior to production of the remaining kiosks.

2.2. Supply % of Item 2.1 Unit: No.

The unit of measure shall be the number of spare LV Kiosks described in 2.2 above to be supplied and delivered to the responsible electrical maintenance personnel.

2.3 150mm² 3 core PILC 11KV Cu Cable Unit m

The unit of measure shall be the cable length in meters supplied, installed, and commissioned. If any the labels shall be included in the rate. Cable Guards to be installed at 3m intervals shall also be included in the rate.

Laying cables in trenches:

Measurement of cables laid in trenches shall be of the actual length of that part of a cable laid in the trench when the cable is finally installed.

Drawing cables into ducts,

(excluding supply and installation of ducts, pipes and conduits). Measurement of cables drawn into ducts, shall be of the actual length of that part of a cable laid in ducts, pipes or conduits when the cable is finally installed.

2.4 150mm² 3 core PILC 11KV Cu Cable Straight Through Joint Unit No

The unit of measure shall be the number of 11kV joint supplied and installed, tested and surveyed and survey data submitted to the engineer. The termination shall be rated for 11kV and be made from document specified material and be in accordance with local supply authority standards.

2.5 95mm² 3-core PVC ECC XLPE Cable Unit m

The unit of measure shall be the cable length in meters supplied, installed, and commissioned. If any the labels shall be included in the rate. Cable Guards to be installed at 3m intervals shall also be included in

the rate.

Laying cables in trenches:

Measurement of cables laid in trenches shall be of the actual length of that part of a cable laid in the trench when the cable is finally installed.

Drawing cables into ducts,

(excluding supply and installation of ducts, pipes and conduits). Measurement of cables drawn into ducts, shall be of the actual length of that part of a cable laid in ducts, pipes or conduits when the cable is finally installed.

2.6 95mm² 3-core PVC ECC XLPE Cable Straight Through Joint Unit No

The unit of measure shall be the number of 11kV joint supplied and installed, tested and surveyed and survey data submitted to the engineer. The termination shall be rated for 11kV and be made from document specified material and be in accordance with local supply authority standards.

2.7. 25mm² Aluminium 3-core PVC ECC SWA PVC LV Cable. Unit: m.

The unit of measure shall be the cable length in meters supplied, installed and commissioned. All

cable ends shall be labelled. The labels shall be included in the rate. Cable Guards to be installed at 3m intervals shall also be included in the rate.

Laying cables in trenches:

Measurement of cables laid in trenches shall be of the actual length of that part of a cable laid in the trench when the cable is finally installed.

Drawing cables into ducts, pipes and conduits:

(excluding supply and installation of ducts, pipes and conduits). Measurement of cables drawn into ducts, pipes and conduits shall be of the actual length of that part of a cable laid in ducts, pipes or conduits when the cable is finally installed.

2.8. 2.5mm² Copper 3-core PVC SWA PVC LV Cable. Unit: m.

The unit of measure shall be the cable length in meters supplied, installed and commissioned. All cable ends shall be labelled. The labels shall be included in the rate. Cable Guards to be installed at 3m intervals shall also be included in the rate.

Laying cables in trenches:

Measurement of cables laid in trenches shall be of the actual length of that part of a cable laid in the trench when the cable is finally installed.

Drawing cables into ducts, pipes and conduits:

(excluding supply and installation of ducts, pipes and conduits). Measurement of cables drawn into ducts, pipes and conduits shall be of the actual length of that part of a cable laid in ducts, pipes or conduits when the cable is finally installed.

2.9. 25mm² 3-core Aluminium PVC ECC SWA PVC LV Cable Termination. Unit: No.

The unit of measure shall be the number of terminations supplied and installed, including glands/clamps for securing the cable. The termination shall be rated for 2000V and be made from heat shrinkable material. Terminations excluded. Cable Guards to be installed at 3m intervals shall also be included in the rate. All joints and connections shall be made by means of exothermic welding.

2.10. 2.5mm² 3-core Copper PVC SWA PVC LV Cable Termination. Unit: No.

The unit of measure shall be the number of terminations supplied and installed, including glands/clamps for securing the cable. The termination shall be rated for 2000V and be made from heat shrinkable material. Terminations excluded. Cable Guards to be installed at 3m intervals shall also be included in the rate. All joints and connections shall be made by means of exothermic welding.

2.11 Cable Warning Tape. Unit: m.

The unit of measure shall be the number of metres supplied and installed (trenching measured elsewhere). The warning tape shall be installed 300mm above MV as well as LV cables.

B3.3.3 TRENCHING AND EARTHWORKS – SECTION C2.2.3

Excavation of all material for trenches, backfill, compaction and removal of excess material.

The volumes of the cable sleeve, cable ways and cable trench excavations shall be calculated according to the length and depth as shown on the drawings or to the bottom of the specified bedding, whichever is the largest and to the minimum base width specified.

The tariff covers the cost to comply with safety and protection regulations, except in the case of particular items listed to cover the cost of deep of excavations, backfill and compaction as well as the removal of any excess material.

The tariff also covers the cost of the same works in tunnels if the contractor wishes to use this method of excavation. No additional payment will be made for such tunnels and no deductions will be allowed for the decrease in the amount of excavation quantities.

3.1. Hand pickable soil (soft soil). Unit: m³.

The unit of measure shall be the number of cubic metres of hand pickable soil removed from the trenches (see general specifications for definition of soil type). LV trenching to be 1150mm deep, Intermediate Voltage trenching to be 1250mm deep and MV trenching to be 1350mm deep. The maximum width of a trench shall be fixed at 450mm.

3.2. Machine excavation (soft rock). Unit: m³.

The unit of measure shall be the number of cubic metres of soft rock removed to form the trenches (see general specifications for definition of soil type). LV trenching to be 1150mm deep, Intermediate Voltage trenching to be 1250mm deep and MV trenching to be 1350mm deep. The maximum width of

a trench shall be fixed at 450mm.

3.3. Hard rock (blasting). Unit: m³.

The unit of measure shall be the number of cubic metres of hard rock removed to form the trenches (see general specifications for definition of soil type). LV trenching to be 1150mm deep, Intermediate Voltage trenching to be 1250mm deep and MV trenching to be 1350mm deep. The maximum width of a trench shall be fixed at 450mm.

3.4. Back filling and compacting. Unit: m³.

The unit of measure shall be the number of cubic metres of backfilling and compaction done to close the trenches (the measurement shall be based on the size of the trench). When backfilling every 150mm shall be compacted to 90% AASHTO. The size of the trench shall be from the top of the bedding to ground level with a trench width maximum of 450mm.

3.5. Sifting of local soil for bedding of the cables. Unit: m³.

The unit of measure shall be the number of cubic metres of bedding sifted and installed in the trenches. The bedding shall have a thermal conductivity of at least 1.2 K.m/W and be approved by the Engineer prior to installation. A 6mm grid shall be used during the sifting process. The bedding shall be 150mm above and below the cable as well as cover the width of the trench (maximum of 450mm).

3.6. Import soil for bedding of cables. Unit: m.

The unit of measure shall be the number of cubic metres of imported soil and installed in the trenches. The bedding shall have a thermal conductivity of at least 1.2 K.m/W and be approved by the Engineer prior to installation. A 6mm grid shall be used during the sifting process. The bedding shall be 150mm above and below the cable as well as cover the width of the trench (maximum of 450mm).

3.7. Core drilling underneath existing road, 150mm Ø sleeve. Unit: m.

The unit of measure shall be the number of metres core drilled successfully under an existing road and surveyed and survey data submitted to the engineer. Additionally, each unit may only be claimed for payment upon signed off inspection sheet, whereby the sleeve is clear of all debris and capped closed.

The depth of drilling shall be at least 1200mm and at most 1500mm below the road surface and extend 5m from edge of road where allowed and min 3m. Included in this rate are 160 mm diameter HDPE sleeves with steel draw wire per meter installed in the core-drilled tunnel and capped on both ends and drilling pit expenses.

3.8. Core drilling underneath existing road, 110mm Ø sleeve. Unit: m.

The unit of measure shall be the number of metres core drilled successfully under an existing road and surveyed and survey data submitted to the engineer. Additionally, each unit may only be claimed for payment upon signed off inspection sheet, whereby the sleeve is clear of all debris and capped closed. The depth of drilling shall be at least 1200mm and at most 1500mm below the road surface and extend 5m from edge of road where allowed and min 3m. Included in this rate are 110 mm diameter HDPE sleeves

with steel draw wire per meter installed in the core-drilled tunnel and capped on both ends and drilling pit expenses.

3.9. 110mm PVC sleeves. Unit: m.

The unit of measure shall be the number of metres of 110mm PVC sleeves installed at a depth of 1500mm through the carriageway rather than core drilling. All related civil works included in rate. Each unit may only be claimed for payment upon signed off inspection sheet, whereby the sleeve is clear of all debris and capped closed.

3.10. 150mm PVC sleeves. Unit: m.

The unit of measure shall be the number of metres of 150mm PVC sleeves installed at a depth of 1500mm through the carriageway rather than core drilling. All related civil works included in rate. Each unit may only be claimed for payment upon signed off inspection sheet, whereby the sleeve is clear of all debris and capped closed.

B3.3.4 LUMINAIRES – SECTION C2.2.4

4.0 General

All luminaires shall be supplied, installed, commissioned and aimed by the contractor. All luminaires are to adhere to Local Municipal Standards and Specifications. All luminaires & Lamps are to adhere to relevant Gauteng Environment standards, Contract & Local Supply Authority specifications, with IP66 Ratings Intact or higher with a rated an ambient temperature of $T_a = 35^{\circ}\text{C}$.

The contractor shall be responsible for installation of the fittings including lamps / LED Modules strictly according to the supplier's requirements and approved compliant lighting simulations submitted at tender stage. Any defective luminaires found after installation will be the responsibility of the contractor and shall be replaced at his cost, within the one year defect liability period.

The lighting installation will comply to SANS 10098-1 & -2 standards or IEC equivalent standards. Should the lighting installation not comply to SANS 10098-1 & 2 standards or IEC equivalent standards upon testing, it will be the contractor's responsibility and at the contractor's own expense to provide a compliant lighting installation. All alternative luminaires or alterations proposed to achieve compliancy will need to be reviewed and approved by the Engineer.

Should a tendered luminaire model become outdated, the contractor is to inform the engineer and clearly state the latest luminaire model that takes the place of the outdated model. Additionally, the necessary lighting simulations are to be submitted to validate that the newer luminaire model is compliant.

The contractor is to submit this information for approval by the Engineer. Any additional costs for the updated luminaire will be for the contractor's own expense.

Only once the commissioned system has operated fault free at full load for 30 days initially without to test the electrical and lighting system and then an additional 30 days with the energy and luminaire monitoring control system operational to test the energy and luminaire monitoring control system, will full payment of all luminaires be allowable, until such time 15% will be retained.

- 4.01 Luminaire - Type L1, Unit: No.
- The unit of measure shall be the number of luminaires supplied, installed on light poles and commissioned per luminaire type specified.
- 4.1 Supply Only 10% of Luminaire - Type L1, Unit: No.
- The unit of measure shall be the number of spare luminaires supplied and delivered to the responsible electrical and lighting maintenance personnel, per luminaire type specified.
- 4.02 Luminaire - Type L2 Unit: No.
- The unit of measure shall be the number of luminaires supplied, installed on light poles and commissioned per luminaire type specified.
- 4.2 Supply Only 10% of Luminaire - Type L2 Unit: No.
- The unit of measure shall be the number of spare luminaires supplied and delivered to the responsible electrical and lighting maintenance personnel, per luminaire type specified.
- 4.3 Testing of Luminaires. Unit: No.
- The unit of measure shall be the number of luminaires commissioned and fully operational after the fulfilment of the testing requirements.
- 4.4 Removal of existing luminaires & Poles Unit: No.
- The unit of measurement shall be the number of existing streetlight luminaires & lamps and poles removed from site and delivered to a local council storage depot. These luminaires and poles are to be removed when temporary lighting is to be replaced with the new lighting design.
- 4.5 Temporary Lighting Unit: Prov Sum
- The unit of measure shall be a provisional sum for maintaining the existing lighting requirements where an existing lighting system has had to be removed for project purposes, payment thereof will be based on the period for which material and labour was used to maintain the existing lighting requirements. Contractor is to submit proof of expenditure for approval before claiming. If there is functioning existing lighting, the existing lighting of the road may not be removed until it can be replaced by the new lighting installation.
- The existing lighting can be used as temporary lighting and be supplied by a temporary supply, but the road is to have lighting at all times during the construction period, until the new lighting design is supplied, installed, commissioned and working properly according to engineer approval.
- Inclusive is the number of functional temporary streetlight luminaires & poles installed, temporary connections supplied and installed and the cost for power consumption. The contractor is to provide all necessary documentation to validate claims for temporary lighting.

B3.3.5 POLES – SECTION C2.2.5

5.0 General

All poles shall be labelled on both sides where possible by means of matt yellow background and matt black paint font with a minimum letter size of 75mm. The labels shall be painted on the sides of each pole, facing 45 degrees towards approaching traffic at a height of 1,5m from the base plate or final ground level.

Where poles are installed in the median, labels shall be painted on both sides.

The mounting height of the luminaires, once installed on the poles is taken to be relative to the centre lane road surface level of each carriageway and is to be maintained to adhere to SANS 10098-1 & -2 standards. A suitable lightning arrestor shall protrude at the top of all masts and poles to protect the luminaires from a direct lightning strike. The lightning arrestor shall not be terminated directly on the connection box. Maintenance tools, 3 units of each type of tool required, to be inclusive in total rate and to be submitted upon project handover.

Poles are to adhere to Local Municipal Standards and Specifications.

5.1. 10.50m Pole. Unit: No.

The unit of measure shall be the number of Galvanised Steel streetlight poles with a mounting height of 10.50m that is supplied, installed correctly, aligned to the Z-axis, to the correct mounting height and commissioned as indicated on the drawings.

All accessories, termination plate, earth stud, wiring in the pole to complete the operation of the light pole are all included in the rate. The wiring to the luminaires shall be by means of 2.5mm² 3-core Surfex cable and shall be included in the rate. Labelling, double band-strapping included in the rate.

The rate also includes the complete trenching, planting of the pole, backfilling and compaction for the installation of the pole. The streetlight poles shall be installed at a depth specified by the manufacturer, if installed in the ground. The pole will be planted such that the access hole will be located (away from approaching traffic) such that personnel can see approaching traffic.

The method for ground installation shall be as follows:

Fill the hole with a 1:6 mix of cement and sifted soil to 300mm below natural ground level and compacted every 300mm to 90% AASHTO. Fill the rest of the hole with non-chemical active soil and compact to 90% AASHTO.

5.2 Cross-arm Framework (Spigots) Items 5.1 Unit: No.

The unit of measure shall be the number of cross-arms supplied; installed and commissioned for the following various approved lighting simulation luminaire arrangements for luminaire types L1

5.3 Supply 10% of Item 5.1 and 5.2 Unit: No.

The unit of measure shall be the number of spare poles/cross-arm frameworks described in 5.1 above to be supplied and delivered to the responsible electrical maintenance personnel.

B3.3.6 POLE FOUNDATIONS AND EARTHING – SECTION C2.2.6

B3.3.7 EARTHING – SECTION C2.2.7

7.1 Earthing of M/S, LV Kiosk and Switches.

Unit: No.

The unit of measure shall be the number of LV Kiosks and control switch earthing systems supplied and installed to achieve an earth resistance smaller or equal to 5 ohms. All the cable connections to the earth electrodes shall be cad-welded, included are earth spikes, earth continuity conductors, terminations and all lugs and insulating material needed to complete the termination.

7.2 Additional Earth Continuity Conductors.

Unit: m.

The unit of measure shall be the length of additional 70mm² earth continuity conductor supplied and installed to achieve an earth resistance smaller or equal to 5 ohms. All the cable connections to the earth electrodes shall be cad-welded.

7.3 Terminating of Additional Continuity Conductors.

Unit: No.

The unit of measure shall be the number of additional earthing terminations supplied and installed. The termination shall include all the lugs and insulating material needed to complete the termination.

7.4 Extra over for the supply and installation of additional 1.5m earth electrodes incl. Cadweld connections of earth conductors.

Unit: No.

The unit of measure shall be the number of additional 1.5 m earth electrode terminations supplied and installed. If the 5 ohm is not achieved with a standard crow foot earthing system, additional earthing enhancement will be done.

7.5 Earth Resistivity Tests.

Unit: No.

The unit of measure shall be the number of soil resistivity tests done. Soil Resistivity tests to be done at each LV Kiosk site. Soil resistivity measurements will be supplied for each mini substation / LV Kiosk and earthing design to be done by the contractor and approved by the engineer based on the results obtained.

7.6 Earth Tests.

Unit: No.

The unit of measure shall be the number of earth system resistance tests done. Resistance of the earthing system shall be measured for each mini substation / LV Kiosk. Resistance readings shall be logged and shall form part of the commissioning tests.

B3.3.8 OTHER SERVICES – SECTION C2.2.8

8.1 ITS & Telecommunication services

Unit: Prov. Sum.

The unit of measure shall be a provisional sum for all works to be done or relating to ITS and telecommunication services, including the relocation thereof, liaison with respective persons, construction or installation of manholes, installation of service sleeves, testing and commissioning of services.

Drawings, specifications, and test procedures will be submitted during the construction phase and will form part of this document.

8.2 110mm Diameter PVC Sleeves. Unit: m.

The unit of measure shall be the length of 110mm diameter PVC sleeves. Supply and install and tested. Each unit may only be claimed for payment upon signed off inspection sheet, whereby the sleeve is clear of all debris and capped closed.

8.3 10mm Diameter PVC slow bends. Unit: No.

The unit of measure shall be the slow bends for the 110mm PVC sleeves. Supply and install and tested. Each unit may only be claimed for payment upon signed off inspection sheet, whereby the sleeve is clear of all debris and capped closed.

8.4 Provision of raised mini-substation platforms Unit: Prov Sum

The unit of measure shall be the submitted cost per 7m x 7m mini-substation ground platform constructed for the 6m x 6m concrete platform, such that all sleeves entering are correct, back-filling of the platform is done with a 1:6 mix of cement and sifted soil to required site level, such that the platform is visible from the road and compacted to 90% AASHTO every 300mm and submitted compaction test results and inspections are approved.

8.5 Relocation of Existing Electrical Services Unit: Prov Sum

The unit of measure shall be a provisional sum for the works to be done for the number of existing electrical services to be relocated, communicated with and approved by the Local Supply Authority and the materials required and works to be done in accordance with the Local Supply Authority standards, specifications and requirements.

Contractor is to submit proof of expenditure for works done and material supplied and installed for approval before claiming.

8.6 Electrical Manholes. Unit: No.

The unit of measure shall be the number of electrical manholes, average inner size of 1mx1m constructed and installed to supply authority specifications and requirements, with vandal resistant access cover, steps to be included. Each unit may only be claimed for payment upon signed off inspection sheet.

8.7 IT Manholes. Unit: No.

The unit of measure shall be the number of electrical manholes, average inner size of 900mx1.2m constructed and installed to supply authority specifications and requirements, with vandal resistant access cover, steps to be included. Each unit may only be claimed for payment upon signed off inspection sheet.

SITE INFORMATION

PART: SITE INFORMATION

TABLE OF CONTENTS

PAGE

1. SCOPE	78
2. Installations by Others	78
3. General Information	78
4. Standards and Regulations	78
5. Environmental and Site Conditions	78
6. Main Services	79
7. Power Supply	79
8. lighting kiosk	79
9. Cabling	79
10. Earthing and Lightning Protection	79
11. lighting	80
12. DESIGN PARAMETERS	81
13. street lighting poles	81
14. Labelling and Numbering	82
15. operating and maintenance Manuals	82
16. Tools and Accessories	82
17. Maintenance and Guarantee	83
18. inspection by the engineer	83
19. Drawings	83
20 Workmanship	86
21 Supervision	86
MEASUREMENT AND PAYMENT	88

STREETLIGHTING ELECTRICAL PROJECT SPECIFICATION

1. SCOPE

This Contract includes the design, supply, delivery, installation, testing, commissioning and guarantee of the following:

- a. Street lighting;
- b. Low voltage cabling;
- c. Low voltage distribution kiosks;
- d. Earthing;
- e. Lightning protection and
- f. Any other installation and materials stated or implied to provide for a complete installation in accordance with the Specification, Drawings and Schedules supplied.

2. INSTALLATIONS BY OTHERS

The following will be provided by others:

- Power supply via miniature substations

3. GENERAL INFORMATION

This Electrical Project Specification shall be read in conjunction with the following Electrical Standard Specifications.

- Latest revision of City of Tshwane, Standard Specification for Municipal Electrical Engineering Work
- Standard Specification for LED Street Lighting Luminaires, included in this tender document.

Detail of all equipment offered shall be provided, during tender stage.

4. STANDARDS AND REGULATIONS

All materials and equipment shall be new and of the standard and quality specified.

The design and manufacture of Electrical Equipment and the complete installation shall be carried out and tested in accordance with the latest issue or amendments of the following Regulations, as applicable:

- SANS 10142 – The Code of Practice for wiring of premises as amended;
- The Occupational, Health and Safety Act, (Act 85 of 1993 and its regulations);
- The local municipal by-laws and regulations and regulations of the local supply authority;
- The Fire Brigade Services Act, 2000 (Act 14 of 2000) and
- The Electricity Act, (Act 88 of 1996).

5. ENVIRONMENTAL AND SITE CONDITIONS

The following information pertains to the Site and Works:

- Nominal LV supply: 400 V; 3 phase; 4 wire with earthed neutral
- Nominal supply frequency: 50 Hz

The Contractor shall ensure that all equipment, electrical or electronic, will be suitable for continuous, reliable operation under these circumstances, and the Contractor shall ensure that all equipment is adequately protected in this regard, whether such protection has been specified in detail or not.

Failure or malfunction of any component of the installation, even if attributable to the quality of supply, will be rectified at the Contractor's expense.

6. MAIN SERVICES

The Contractor shall familiarize himself with the positions of the other main services, i.e. pipelines, water pipes, storm water sleeves and sewer pipes and co-ordinate these services to ensure an unobstructed path for any cable installations.

Should obstructions be identified these must be brought to the attention of the Engineer as soon as possible.

7. POWER SUPPLY

Bulk power supply shall be provided from Tshwane miniature substations. The contractor shall be responsible for all cabling between miniature substations, lighting kiosks and all street lighting.

8. LIGHTING KIOSK

Lighting kiosk shall be similar to the existing kiosks supplied by PPS for Simon Vermooten Road.

The kiosk shall be a light grey colour.

The kiosk earth connection shall be connected underground to the Minisub earth with an aerial bundle conductor (ABC), which shall be equivalent to 70mm² copper conductor.

The kiosk shall be manufactured from 3mm, 3CR12 with electronic cyber lock and 3pin locking mechanism and shall be mounted on a concrete plinth. Designs shall be submitted for approval by the Engineer and Tshwane Electrical Department.

Location of lighting kiosks shall be as indicated on the drawings. Power supply will be from the nearest miniature substation.

The contractor shall be responsible for the complete installation, including any required concrete plinth or base.

9. CABLING

Cable sizes, types and approximate lengths are as shown on the Drawings and in Bill of Quantities. Final cable lengths shall be measured on site.

10. EARTHING AND LIGHTNING PROTECTION

A complete lightning protection installation shall be provided using surge arrestors, with indication, at the lighting luminaire and distribution kiosk. The arrestors used shall be a combination of Dehn type DEHNcord and DEHNshield arrestors. An overall lightning protection design for street lighting shall be submitted to the Engineer for approval.

11. LIGHTING

The Contractor shall be responsible for the complete street lighting and power distribution as shown on the drawings.

The lighting installation shall be as indicated on the Drawings. Fittings offered by the Contractor shall be as indicated on the Drawings. Equivalent fittings can be offered if approved by the Engineer and Tshwane Municipality.

The contractor shall use the latest layout provided during construction phase to submit a final lighting design for approval, using design parameters included in this specification.

Luminaires shall be supplied and installed complete with lamps, ballast's, control gear, diffusers, mounting facilities, etc., as applicable. All fittings shall be new and unused and shall be delivered to site as packed by the supplier. Fixing of luminaires shall not compromise the protection rating of the luminaire.

All lamps and control gear shall be rated for the supply voltage of 220V-240V as specified.

The permanent luminaires intended for installation shall not be used for temporary lighting during construction. The Certificate of Completion for the installation will not be finalized unless all light fittings and lamps are in working order.

All access holes shall be sealed off with compression glands and other suitable covers to ensure a weather proof installation, as required.

Luminaire tilts shall be as indicated on the drawings.

Lighting for the new and existing underpass underneath bridge 1 shall be provided as shown on the drawing. Light fittings shall be surface mounted with wiring inside concealed conduit. The conduit shall be chased in concrete after completion of the bridge. Power supply to the light fittings shall be from a cable installed in a surface mounted steel pipe with a termination box at ceiling height.

A lighting management system shall be installed, which shall provide remote management and control. The system shall control lighting levels and switching based on the time and day of the week.

The operators shall be able to access the system from a standard web browser to print operational reports or override the switching schedules for individual groups or a specific luminaire.

The system shall report the status of power consumption, power factor, load current and lamp run hours for every individual luminaire. This will enable the operator to plan maintenance and replacement of lamps.

Full detail of this lighting management system, including equipment detail, sim card detail, cabling and communication detail and after sales support shall be submitted at tender stage. A system without sim

cards at each luminaire will be preferred.

12. DESIGN PARAMETERS

Street lighting design shall be based on SANS 10098-1 'The Lighting of Public Thoroughfares'

The road is classified as a lighting category A3 'Important urban traffic routes, for speed limits not exceeding 60 km/h' with a maximum of 300 vehicles per lane per hour during darkness in terms of table 1.

The specifications for an A3 road are:

- Minimum average luminance = 0.6 cd/m^2
- Overall luminance uniformity = 0.4 min
- Longitudinal luminance uniformity = 0.5 min
- Threshold increment = 20% max

The walkway/cycle route is classified as a lighting category B2 'Residential streets in medium density residential areas' in terms of table 1.

The specifications for a B2 road are:

- Minimum average horizontal illuminance = 3 lux
- Minimum horizontal illuminance = 0.6 lux
- Minimum semi-cylindrical illuminance = 1 lux

13. STREET LIGHTING POLES

Street lighting poles shall be similar to the existing scissor poles supplied by Sectional Poles for Simon Vermooten Road. See drawings included.

The operating spanner for these poles shall not be the standard type as shown on the drawing. Detail of a unique spanner to be used shall be submitted with final construction drawings.

Fixed poles shall be installed for footpath.

Heights above ground level (Z) are shown on the drawings.

Lockable double pole isolators shall be fitted in the base compartment of each lighting column or traffic sign into which cables are to be terminated.

Armoured cables shall be terminated by means of a 3-part compression gland comprising armour locking ring, locknut, earth terminal and shroud.

The cable armour shall be bonded to the earth terminal block in each column and continuity achieved throughout the earth loop including the column.

The installation shall be earthed and labelled in accordance with SANS 10142-1:2006

Armoured cables shall not rely upon the steel wire armour alone for the return path to earth.

A separate dedicated earth terminal block shall be fixed to the baseboard of each column and the earthing terminals of all equipment shall be bonded separately to this terminal block. Crimped connections are to be used wherever possible.

The dedicated earth terminal shall be supplied irrespective of any other earth terminal e.g. within the cut-out or on the column.

The main earthing conductor shall be the equivalent cross sectional area of the incoming phase conductor.

All screwed earth connections shall be made between two brass washers.

Earthing labels shall be fitted at every main or supplementary earth bonding point. Labels shall be fitted with Traffolyte type and be in accordance with SANS 10142.

All screws, washers and bolts shall be manufactured from stainless steel or brass.

Designs shall be submitted for approval by the Engineer and Tshwane Electrical Department.

Spare lighting poles shall be provided as shown in the bill of quantities.

14. LABELLING AND NUMBERING

Equipment shall be marked clearly in accordance with the Drawings.

Equipment not designated or numbered on the layout Drawings shall be labelled by means of a unique numbering system for ease of identification. The Contractor shall apply the numbering system as prescribed by the Engineer.

All cables shall be clearly labelled at both ends. Each end shall be labelled to identify the equipment it is connected to on its other end. More than one cable of the same type shall be distinguished by a second suffix in numerical order.

Draw boxes and terminals shall be numbered and labelled.

Labels shall be permanent and indelible.

Numbering and labelling shall be such that, during maintenance, the wiring can be traced by using the Record ("As Installed") Drawings.

15. OPERATING AND MAINTENANCE MANUALS

Three sets of O&M Manuals shall be required before final commissioning.

16. TOOLS AND ACCESSORIES

All tools, special tools and accessories required for the normal operation and maintenance of all the equipment and systems supplied, shall be included in this Contract. This shall include tools to lower a scissor mast.

All keys, tools and special tools shall be in duplicate and handed to the Engineer upon completion. The Contract shall be deemed to be incomplete until this requirement has been met.

The Contractor shall ensure that all tools and equipment required are available during inspections and testing.

17. MAINTENANCE AND GUARANTEE

The Equipment and installation included in this Contract shall be guaranteed and maintained in all respects for the duration of the Defects Notification Period.

The Contractor shall, for the full duration of the Defects Notification Period, be responsible for all work and equipment replacements required, including labour, travelling costs, the replacement of lamps and fuses, etc. Renewals or repairs resulting from misuse, however, will not be made at the expense of the Contractor. The Contractor shall repair/replace faulty equipment within 48 hours of notification.

The Contractor shall submit full details of his maintenance and repair service facilities, including statutory holidays, weekends, after hours and normal hours.

The Contractor shall stock the spares during the Defects Notification Period. All repairs to be made to the installation due to causes not covered by the guarantees shall be done utilising the above material.

At the end of the Defects Notification Period the remaining material shall be documented and handed over to the Employer for the ongoing maintenance of the installation.

18. INSPECTION BY THE ENGINEER

Inspection of equipment shall be carried out by the Engineer, his appointed representative or a nominated and approved inspection authority at the manufacturer's works.

The Engineer's inspection shall in no way relieve the Contractor or Sub-Contractors of any of their obligations to design, manufacture and supply equipment of superior quality and workmanship in accordance with the specification.

19. DRAWINGS

19.1 Drawings Issued by the Engineer

The drawings that were issued as part of the tender documentation are not final design drawings and are only sufficient for tendering purposes.

19.2 Contractor's Drawings

The Contractor shall submit drawings for the following purposes:

Concept Design	:	for assessment
Manufacturing (Workshop)	:	for approval
Installation	:	for approval
As-built	:	for records

19.3 Concept Design Drawings

- a) The Contractor shall submit concept design drawings for review by the Engineer before commencing with manufacturing drawings.
- b) Concept drawings submitted by the Contractor shall give sufficient information to make a proper assessment of the Equipment offered together with sufficient detail to enable the dimensions and general arrangement of the Equipment to be determined. All the important parts shall be shown in detail.
- c) Drawings shall include details of parts to be built into, and loads to be transferred to, the civil engineering works, routes and sizes of cabling, cable ducts or trunking, hydraulic pipework, description of erection methods, operating and control units, position indicators and details of connections to any other equipment.

19.4 Manufacturing (Workshop) Drawings

- a) Before commencing with fabrication, drawings shall be submitted for approval by the Engineer. These drawings shall cover the general arrangement, assembly and supporting detailed drawings of the equipment offered and their related ancillary equipment.
- b) The drawings shall provide complete information regarding thickness and types of material, finishing of surfaces, fixing and connections, standard parts, tolerances, clearances with regard to other machine parts or building faces and in general everything that may have a bearing on the satisfactory fabrication, erection and operation of the equipment shown on these drawings.
- c) Electrical Equipment wiring and or hydraulic diagrams for the sub-assemblies such as distribution and control boards, as well as overall integrated cabling and wiring diagrams for the complete installation, shall be prepared and submitted in a similar fashion to these drawings.
- d) These drawings shall be submitted within the period(s) as indicated on the Construction Programme and agreed with the Engineer. All drawings submitted must signify authorisation by the Contractor. Submission of the Contractor's Drawings shall be accompanied by one or more updated index sheets prepared on A3-size sheet, listing all drawings with numbers, titles and status of amendments.
- e) Two weeks after submission by the Contractor, or 10 days in the event of re-submission, the Engineer will return one of the above-mentioned prints either with his certified approval or else with his comments regarding any amendments that may be required. A drawing returned to the Contractor for amendment purposes shall be re-submitted in its amended form within 2 weeks of the date of receipt of the drawing by the Contractor.
- f) Approval of the above drawings by the Engineer shall only signify approval of the general design and layout and shall not make the Engineer liable for any error by the Contractor.
- g) Priority shall be given to those drawings regarding items that affect the concrete or other construction work of a civil engineering nature. These drawings shall detail in full, the necessary provisions to be made in the concrete or other supporting structure(s) for casting in of embedded parts and anchors for

- fixing of built-in parts and equipment
- h) All the foundation details and the positions and dimensions of all connecting rods, pockets, vent ducts, cable ducts, anchor bolt holes and similar items, as well as aligning, fixing, anchoring and second stage concrete requirements must be clearly indicated and detailed on these drawings with the general requirements for built-in parts.
- i) The magnitudes and directions of all forces and loads, both static and dynamic, exerted by the Equipment on the supporting concrete structure shall be clearly and fully detailed on the Contractor's Drawings. Any special requirements to prevent transmitting possible vibrations must also be shown.

19.5 Installation Drawings

- a) Not later than 21 days after the proposed Equipment has been given approval, drawings shall be submitted to allow for adequate site preparation before the arrival of the Equipment. These drawings shall offer the necessary details for the programming of civil works, including foundation details and anchor bolts.
- b) The Engineer has the right to suspend manufacture until a set of drawings, calculations, a draft Operation and Maintenance Manual and Quality Control Plans (for the manufacture and corrosion protection including data sheets of paint and abrasives used) are in his possession and approved in principle.

19.6 As-built Drawings

- a) On completion of the Works, the Contractor shall deliver to the Engineer's office one complete set in triplicate of high quality paper copies together with an electronically saved version preferably on Compact Disc of the Contractor's Drawings, updated to reflect the as-built information. These drawings must be clearly marked as "As Built".
- b) These drawings shall contain general arrangements, assemblies, parts lists (including part numbers) and complete component details as well as wiring and hydraulic diagrams. These items are required in draft form before the Tests on Completion are commenced and in final form before Taking Over in terms of the General Conditions of Contract.
- c) Layout Drawings shall be marked up by the Contractor showing all dimensions to buildings, including the relative positions of underground cables.

19.7 Drawing Format

- a) Drawings provided by the Contractor shall be to scale size A3 produced in hard copy and electronically in .pdf format. Each Drawing shall show the following particulars in the lower right hand corner:-
- Name of Employer;
 - Name of Engineer;
 - Name of Contractor;
 - Project title;
 - Contract number;
 - Title of Drawing (Location, item and detail);
 - Scale;
 - Date of Drawing;
 - Details of electrical supply (where applicable);

- Drawing number; and
 - Revision identification.
- b) Dimensions on all Drawings shall be metric.
- c) A blank space 45mm by 30mm shall be provided as an extension of the title block for the Engineer's approval stamp. Provision shall be made for details of revisions to be recorded above the title block. Prints of Drawings shall be in the form of black lines on a white background.

19.8 Notes and Part lists

- a) Notes on the drawings shall be in English and dimensions in the metric system in SI units with all scales clearly stated.
- b) The Parts Lists shall be part of the assembly drawing unless otherwise agreed to by the Engineer.

19.9 Drawing Identification and Number

- a) All drawings shall be consecutively numbered.
- b) Each drawing shall be provided with a title block as per the construction drawings issued by the Engineer. A pro-forma drawing frame and title block is available electronically from the Engineer.

19.10 Quality and Format of Drawings

- a) The standard of draughtsmanship and detailing shall conform to the requirements of SANS 10111 & 10143. Drawings shall be clear, black line on white paper, unfolded and suitable for microfilming purposes.
- b) Unless otherwise agreed to by the Engineer, the Contractor's Drawings shall be prepared on A3-size (297 x 420mm) high quality paper. The size of the drawing shall not compromise the clarity of the prints.
- c) Drawings shall be submitted in hard copy and electronically in Pdf format.

20 WORKMANSHIP

The Contractor shall only employ competent staff to execute the installation.

The Contract shall be executed with the best workmanship in a workmanlike manner and to the satisfaction of the Engineer.

Should any material or workmanship not be to the satisfaction of the Engineer, it shall be rectified at the cost of the Contractor and all rejected material shall be removed from site.

The Contractor shall be responsible for the correct and complete erection of the Installation. Inspections by the Engineer shall not release the Contractor from this responsibility.

21 SUPERVISION

The Contractor shall provide full time supervision while staff is working on the Contract.

Part C3: Scope of Works

The person nominated by the Contractor to supervise the works shall have the authority to take instructions on behalf of the Contractor.

MEASUREMENT AND PAYMENT

001 Supply and installation of lighting kiosk00

Unit: number (No)

The rates shall include full compensation for the design, supply, delivery, installation and commissioning of lighting kiosk. The price shall include kiosk, all circuit equipment and control equipment as specified and shown on drawings and all factory and site testing.

002 Supply and install Earthing and Lightning Protection

Unit: number (No)

Unit: length (m)

Unit: lump sum (Sum)

The rates shall include full compensation for the design, supply, delivery, installation and commissioning of an earthing and lightning protection system complete with all conductors, surge arrestors, earth rods, isolators, bolts, nuts, welding, copper, trenching and other usable materials to complete the installation, including earth conductivity and earth mat resistance tests.

003 Supply and installation of luminaires

Unit: number (No)

The Supply and Installation rate shall include for all lamps, control gear, surge protection, isolators, terminal blocks, fixing material and support brackets. It shall also include for all lighting design to be issued for approval.

004 Supply and installation of cabling and wiring

Unit: length (m)

Cable and wiring lengths are approximate lengths. Installed cables and wires will be measured on site.

Installation rates shall include for all clamping, strapping and cable tag marking. Trenching is priced separately.

005 Supply and installation of cable terminations and joints

Unit: number (No)

The rates for cable terminations and joints shall include for cable glands/termination kits, shrouds, crimped lugs, connection to terminals, core ferrule numbers and cable tag number inside the compartment or cable connection box.

006 Cable trenches

Unit: length (m)

The rates shall include full compensation for excavation, top and bottom layer of soft sifted soil, cable marker tape and backfill as specified.

007 Supply and installation of lighting management system

Unit: lump sum (Sum)

Supply and install lighting controller system complete with sensors, controllers, software and power supply as specified.

008 Supply and installation of street lighting poles

Unit: number (No)

The rates shall include full compensation for the design, supply, delivery and installation of street lighting poles. The price shall include all civil foundation work, concrete plinths, earthing, terminations, labelling and isolators as specified.

009 Commissioning

Unit: lump sum (Sum)

The rates shall include full compensation for commissioning, including labour, supervision, materials, instruments etc., necessary for the testing, assuming responsibility for all operations necessary during the

testing (including attendance on tests witnessed by the Engineer), remedial work and any other work as specified.

010 Special tools and test equipment

Unit: lump sum (Sum)

The Contractor shall allow for the tools and test equipment considered to be necessary for all testing as specified.

The rates shall include full compensation for the supply and delivery to Site of all special tools and test plant as specified, including lowering equipment for scissor masts.

011 O + M manuals and Drawings

Unit: Lump Sum (Sum)

The rates tendered against the items in the Price Schedules shall include for full compensation of all costs incurred in the preparation of O+M manuals and drawings and submission of copies as scheduled for the different phases i.e. manufacturing, installation and As Built drawings. Pro-rata payment will only be effected after the O+M manuals and drawings have been approved by the Engineer.

**012 Supply and installation of conduit and termination boxes
required for bridge lighting.**

Unit: number (No)

Unit: length (m)

Conduit lengths are approximate lengths. Installed conduit will be measured on site.

Installation rates shall include for all saddles, fastening and chasing into concrete and the installation method as specified.

STANDARD SPECIFICATIONS FOR LED STREETLIGHT LUMINAIRES

1. Scope

This specification covers the City of Tshwane's requirements for LED street lighting luminaires for use on a 230V ac supply voltage at 50Hz.

The service provider shall be required to offer and supply LED street light luminaires suitable for operation in an ambient temperature environment of at least 35°C, without reducing the life time of the luminaires with a maximum of 20% light depreciation.

The design life shall be in excess of 25 years.

2. Standards

The following standards contain provisions which, through reference in this text, constitute requirements of this specification.

- SANS 121 - Hot dip galvanized coatings on fabricated iron and steel articles – Specifications and test methods
- SANS 475 - Luminaires for interior lighting, street lighting and floodlighting – Performance requirements
- SANS 1088 - Luminaires entry and spigots
- SANS ARP 035 Guidelines for the installation and maintenance of street lighting
- SANS 10098 – 1 Public lighting - Part 1; The lighting of public thoroughfares.
- SANS 60529/ Degrees of protection provided by enclosures (IP Code)
- IEC 60529
- SANS 60598/ Luminaires – Part 1: General requirements and tests
- IEC 60598
- SANS 60598/ Luminaires – Part 2-3: Particular requirements -
- IEC60598-2-3 Luminaires for road and street lighting
- OHSACT (ACT 85 of 1993) Occupational Health and Safety ACT and Regulations

3. Luminaire construction

The luminaire shall consist of a separate LED, power supply and spigot compartments and shall incorporate a levelling device.

The replacement (upgrading and service) of the LED unit and the driver/power supply shall be possible without removing the whole luminaire. It shall be done by means of replacing only the optical/gear compartment with a hinging mechanism.

The power supply shall automatically disengage when opening the luminaire.

All compartments of the luminaire shall have a minimum IP rating of IP66 and only stainless screws shall be used.

The protector shall be smooth, for easy cleaning, and shall be manufactured of tempered glass of at least (IK07) or high-impact acrylic (IK10).

The cooling fins shall be designed in such a manner to prevent the accumulation of dirt, thus ensuring the continuous effective cooling. The cooling rib height to width ratio may not exceed 0.7. Additionally, the top surface shall be curved in shape.

Direct conduction & maximized surface for external heat exchange shall be provided.

Luminaire closure shall be by means of a single movement clip mechanism at the rear of the luminaire and secured by a tamper-proof screw to minimize theft and vandalism.

The control gear compartment shall be incorporated into the luminaire housing.

The luminaires shall be robustly constructed from marine grade (LM6) die cast aluminium to prevent undue deterioration in its safe operation or appearance during the expected service life.

Bidders shall submit a metallurgical report from an independent metallurgist confirming the grade of aluminium for all luminaires offered.

4. Components

LEDs shall have a lifetime residual flux of 100 000 hours at 70% lumen maintained at a maximum performance temperature of $T_q 25^{\circ} C$ and a safety maximum ambient temperature of $T_a 35^{\circ} C$. Documentary evidence from the LED manufacturer, by means of an appropriate datasheet, confirming the statistical correlation, shall be provided.

LED shall be high efficiency LED's with an efficiency larger than 100 lumens/watt and absolute photometry (CRI) larger than 70. Documentary evidence of compliance to this clause shall be submitted with the tender.

Colour temperature shall be neutral white (4 000K). A report from the LED vendor, for LED's used in the luminaire, shall be submitted, which shall include the following documentary evidence:

- LED drive current.
- LED manufacturer data that clearly correlates LED junction temperature and LED drive current to lumen maintenance.
- The LED datasheets, indicating the B_{yy} , L_{xx} data, as provided by the LED manufacturer.
- Documentary evidence, confirming that the failure of one LED will not cause additional LED's to fail.

The PCB shall incorporate a temperature monitoring sensor which shall reduce the current to protect the LEDs at higher than rated ambient temperatures. The temperature sensor is not intended to switch off the LEDs at high temperatures.

Switching/Dimming control shall be available in three different options:

- Downward facing daylight switch
- Pre-programmable stand-alone dimming
- Intelligent remote control management

The terminal blocks of the incoming supply shall be independently fixed and fastened to the body of the luminaire or to the mounting plate. The terminal blocks shall be capable of accepting two 2,5 mm conductors each.

The internal wiring of the luminaire shall be flexible and suitably insulated to withstand the voltage and maximum temperature to which it is subjected to in service. Wiring shall comply with the requirements clause 5.3 of IEC 60598-1.

Wiring to the LED module shall be suitably sealed to prevent ingress of insects into the LED module compartment.

5. Power supply

The nominal input voltage is between 108-305VAC (50Hz)

The unit shall have the following features:

- The power factor shall be rated at ≥ 0.95 .
- Expected lifetime of driver shall match that of the LED ie 100 000 hours.
- Operating temperatures shall be from -15deg to +60deg on the housing (case temperature).
- Operating humidity shall be from 20% to 95%.
- The control gear shall incorporate a thermal switch for protection when exceeding the case temperature.
- The unit shall be EMC compliant to the IEC55015 and IEC61347-1 standard.
- The unit shall be able to withstand surges up to 10kV/10kA by means of an external surge protection device mounted inside the gear compartment and shall be easily replaceable.

6. Spigot entries

Spigot entries shall be designed to fit easily over the bracket pipe and shall be truly parallel to the fitting axis and it shall comply with SANS 1088.

The luminaire shall be secured to the spigot by means of at least two stainless steel M8 grub screws, as specified in ISO 4762. This shall be done from the inside of the luminaire to minimize the risk of vandalism and theft.

An additional safety screw, with a special coded screw head, shall protect the luminaire against pilferage.

7. Provision for earthing

The luminaire shall be earthed in accordance with clause 13 of the Electrical Machinery Regulations of the OSH Act (Act 85 of 1993).

The earthing of the luminaire shall comply with sub clause 7.2 of IEC 60598 – 1. All parts of an earth terminal shall be made of brass or other corrosion resistant metal and the contact surface shall be bare metal and not be painted or varnished surfaces.

Metal parts of luminaires which may become alive in the event of an insulation fault and which are not accessible when the luminaire is mounted but liable to come into contact with the supporting surface shall be permanently and reliably connected to an earthing terminal.

For luminaire with detachable parts provided with connectors and similar connection devices, the earth connection shall be made before the current-carrying contacts are made and the current-carrying contacts shall separate before the earth connection is broken.

All earth connections shall be effected by means of suitable lugs appropriately made to avoid all possibility of electrolytic corrosion.

An earth connection shall be provided in all instances, even if the luminaire is fully insulated and even if all conductive parts, which could become alive in the event of insulation fault, are not accessible.

Protection against electric shock shall be provided for all methods and positions of installation in normal use. Protection shall also be maintained after removal of all parts which can be removed by hand, except those parts of lampholders specified in sub-clause 8.2.1 of IEC 60598 – 1.

8. Photometric requirements

The tenderer shall submit the calculations, as per SANS 10098.

Detailed calculations, confirming the results, shall accompany the tender document.

The photometric data submitted shall be based on measurements undertaken by an internationally certified lighting laboratory.

Copies of the photometric report shall be submitted and shall contain the measuring matrix, with measurement points as defined by CIE 140, illustrating:

- The candela values, at an ambient temperature of 25°C.
- The description and photography of the luminaire tested.
- The supply voltage and LED currents during testing.

The calculation shall be based on the following criteria:

- LED lumen depreciation: 20%
- Maintenance factor: 0.9 (allowing for a 10% light loss due to dirt on the protector surface).

5. Streetlight Luminaire Markings

Each luminaire shall be distinctly and durably marked with black writing on a white background using 25mm high lettering on the luminaire such that it is clearly visible from the ground; with the following information;

- Name or trade mark of manufacturer and date of manufacturer
- Name of supplier and luminaire model name
- Rated wattage of the luminaire and lamp type eg. 40W LED

6. LED Luminaire Test Reports

The following test reports shall be submitted with the bid documents and failure to submit the reports shall result in automatic rejection of the offer:

Part C3: Scope of Works

- Type test reports to proof luminaire compliance to IEC 60598 -1 and IEC 60598-2-3.
- The test reports shall be issued by SANS or IEC accredited test authority.

The performance test reports shall include the following:

- Photometric test
- Endurance test and thermal test
- Resistance to corrosion
- Insulation resistance and electric strength
- Humidity test
- Mechanical strength test
- Electrical test
- IP rating test
- Power factor

APPENDIX A

LIGHTING SCISSOR MAST

Part C3: Scope of Works

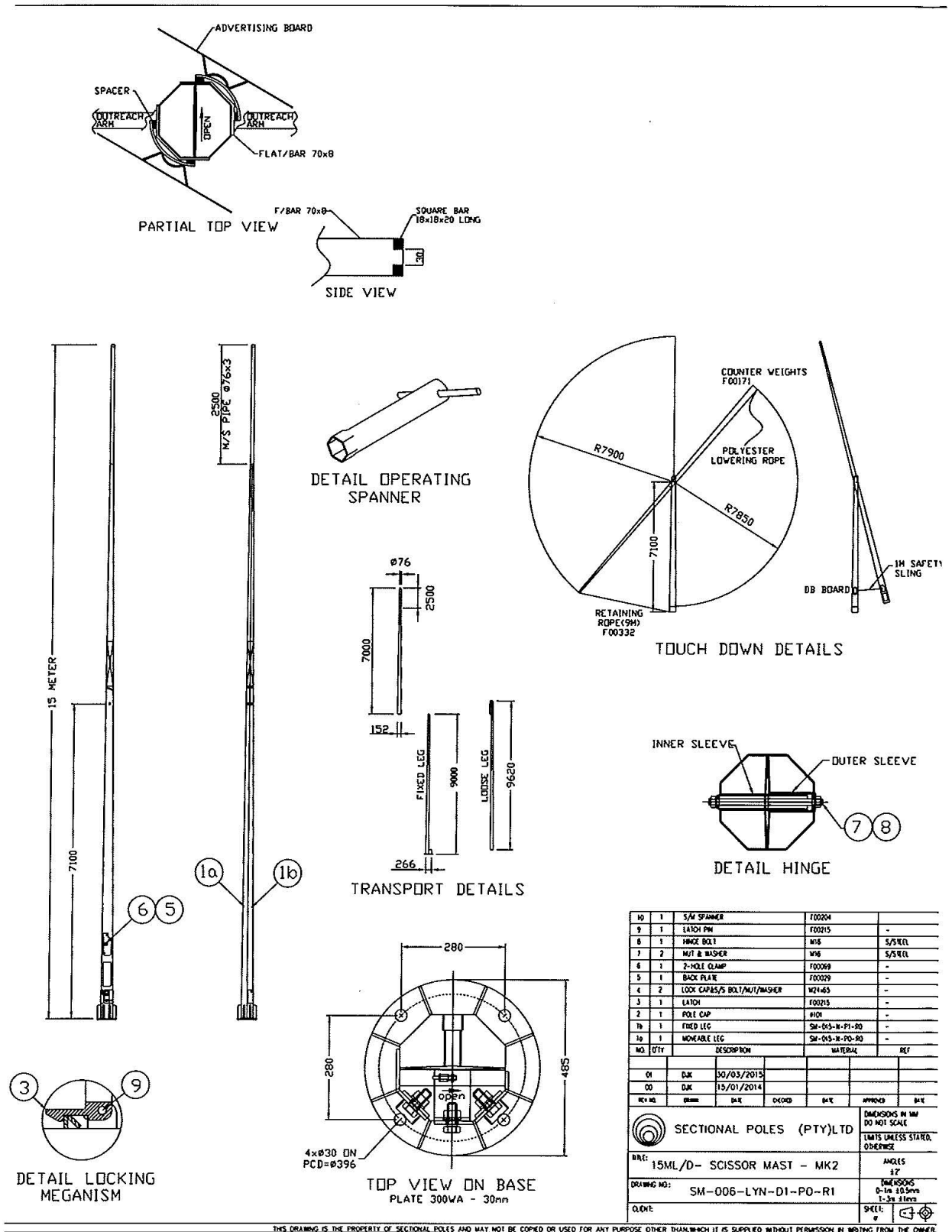

Part C3: Scope of Works

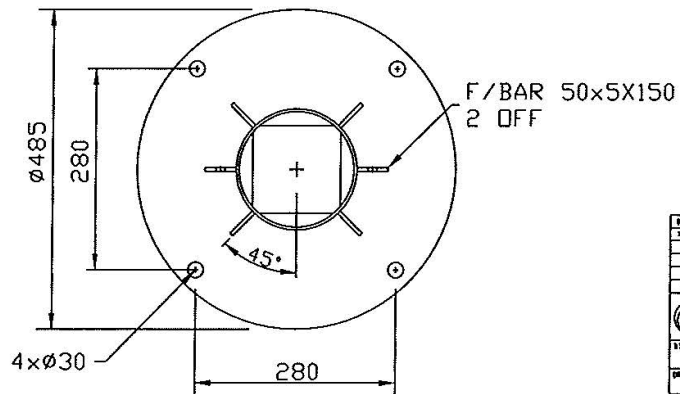
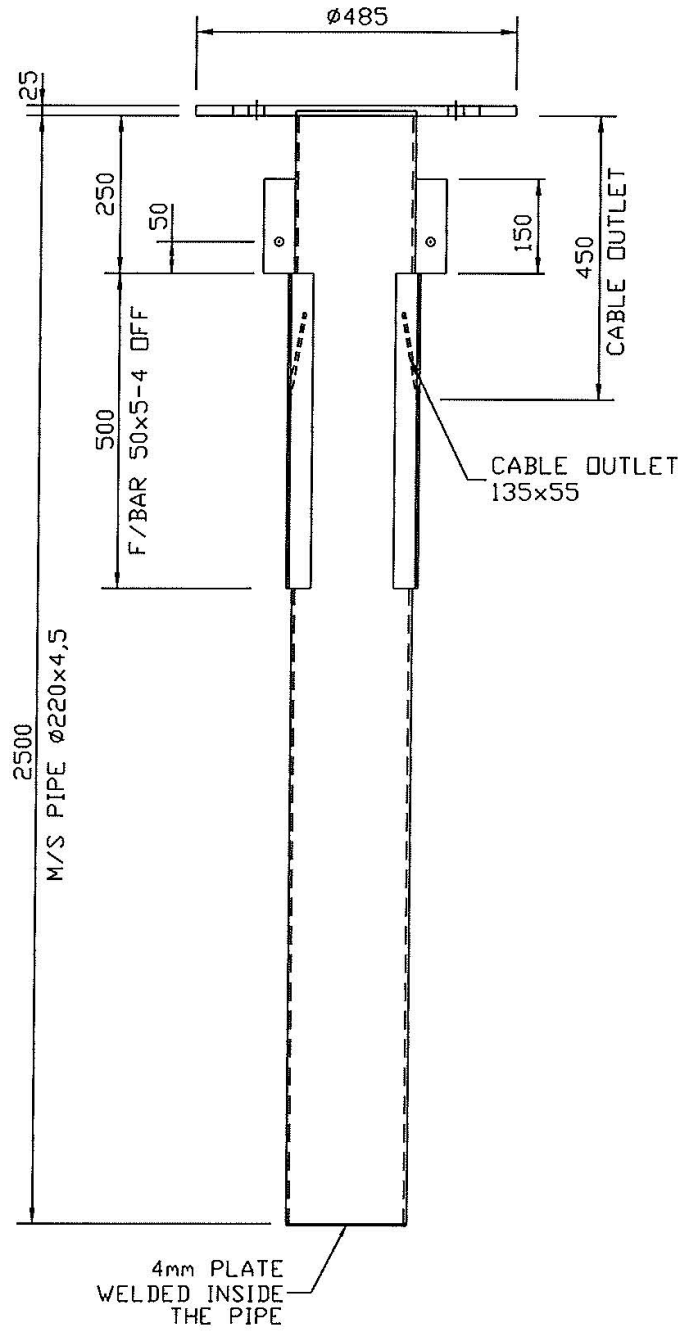

NO	REV	DESCRIPTION	DATE	BY	CHK
00					
01					
02					
03					
04					
05					
06					
07					
08					
09					
10					
11					
12					
13					
14					
15					
16					
17					
18					
19					
20					
21					
22					
23					
24					
25					
26					
27					
28					
29					
30					
31					
32					
33					
34					
35					
36					
37					
38					
39					
40					
41					
42					
43					
44					
45					
46					
47					
48					
49					
50					
51					
52					
53					
54					
55					
56					
57					
58					
59					
60					
61					
62					
63					
64					
65					
66					
67					
68					
69					
70					
71					
72					
73					
74					
75					
76					
77					
78					
79					
80					
81					
82					
83					
84					
85					
86					
87					
88					
89					
90					
91					
92					
93					
94					
95					
96					
97					
98					
99					
100					