

Title: **PHASE CONDUCTOR
STANDARD FOR ESKOM
OVERHEAD LINES**

Unique Identifier: **240-152844641**

Alternative Reference Number: **N/A**

Area of Applicability: **Engineering**

Documentation Type: **Standard**

Revision: **2**

Total Pages: **57**

Next Review Date: **March 2026**

Disclosure Classification: **Controlled
Disclosure**

Compiled by



**Prashant Mathuradas
Senior Engineer – Line
Engineering Services**

Date: 28/01/2021

Reviewed by



**Bharat Haridass
Senior Consultant – Line
Engineering Services**

Date: 28/01/2021

Reviewed by



**Ravi Singh
Chief Engineer – Line
Engineering Services**

Date: 20/01/2021

Authorized by

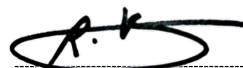

**Riaz Vajeth
LES Senior Manager &
SCOT Chairperson**

Date: 4 Feb 2021

Content

	Page
1. Introduction.....	3
2. Supporting Clauses	3
2.1 Scope	3
2.1.1 Purpose.....	3
2.1.2 Applicability	3
2.2 Normative/Informative References.....	3
2.2.1 Normative.....	3
2.2.2 Informative	3
2.3 Definitions.....	4
2.3.1 General	4
2.3.2 Classification	4
2.4 Abbreviations.....	4
2.5 Roles and Responsibilities	4
2.6 Process for monitoring	4
2.7 Related/Supporting Documents	4
3. Requirements	5
3.1 General.....	5
3.2 Standard Drum Sizes	5
3.3 Fabrication.....	5
3.4 Matched set requirements.....	6
3.5 Lay Ratios	6
3.6 Length	6
3.7 Conductor Marking	7
4. Test Requirement	7
5. Packing and marking requirements.....	8
5.1 Drums	8
5.2 Drum Marking.....	9
5.3 Additional notes.....	10
6. Authorisation.....	10
7. Revisions	10
8. Development team	10
9. Acknowledgements	11
Annex A – Example of Technical Schedule A and B.....	12
Annex B – Conductor Strand Marking.....	53
Annex C – Conductor properties, ampacity and drum properties	54
Annex D – Typical size wooden drum showing Eskom branded flange.....	57

1. Introduction

This document details the specifications of overhead power line conductors for Eskom Transmission and Distribution.

2. Supporting Clauses

2.1 Scope

This standard covers the technical, manufacturing and testing requirements for aluminium conductor with steel reinforcement (ACSR), all aluminium alloy conductor (AAAC) and all aluminium conductor (AAC) for use on Eskom's overhead power lines.

2.1.1 Purpose

This document outlines technical, manufacturing and testing requirements relating to ACSR, AAAC and AAC conductors.

2.1.2 Applicability

This document shall apply throughout Eskom Holdings Limited Divisions.

2.2 Normative/Informative References

Parties using this document shall apply the most recent edition of the documents listed in the following paragraphs.

2.2.1 Normative

- [1] SANS 61089: 1991, Round wire concentric lay overhead electrical stranded conductors
- [2] IEC 60888: 1987, Zinc-coated steel wires for stranded conductors
- [3] IEC 60889: 1987, Hard-drawn aluminium wire for overhead line conductors
- [4] IEC 61394: 1997, Characteristics of greases for aluminium, aluminium alloy and steel bare conductors
- [5] Cispr TR 18-2:2017, Radio interference characteristics of overhead power lines and high voltage equipment – Part 2: Methods of measurement and procedure for determining limits.
- [6] SANS10005: The Preservative treatment of timber
- [7] ISPM 15: Guidelines for regulating wood packaging material in international trade
- [8] 32-9: Definition of Eskom documents.
- [9] 32-644: Eskom documentation management standard.
- [10] 240-75670386: Operating Manual of the Steering Committee for Technologies (SCOT)
- [11] 240-47172520 TRMSCAAC: The Standard for the construction of overhead power lines (latest revision)
- [12] 240-147806256: Determination of conductor ratings in Eskom

2.2.2 Informative

None

2.3 Definitions

2.3.1 General

Definition	Description
All aluminium alloy conductors (AAAC)	A conductor comprising helically wound aluminium alloy wire
All aluminium conductors (AAC):	A conductor comprising helically wound hard drawn aluminium wire.
Aluminium conductor, steel reinforced (ACSR)	A conductor comprising hard-drawn aluminium strands helically wound around steel reinforcing strands
Bare conductor	A conductor without any insulating covering
Conductor	An electrical conductor arranged to be electrically connected to a source of electrical energy.

2.3.2 Classification

Controlled disclosure: controlled disclosure to external parties (either enforced by law, or discretionary).

2.4 Abbreviations

Abbreviation	Description
AAAC	All aluminium alloy conductors
AAC	All aluminium conductors
ACSR	Aluminium conductor steel reinforced
GSW	Galvanized steel wire.
OHS ACT	The Occupational Health and Safety Act, 1993 (Act 85 of 1993)
QITP	Quality Inspection Test Plans
UTS	Ultimate Tensile Strength.

2.5 Roles and Responsibilities

It is the responsibility of the engineers, commercial representatives, end user and manufacturers to completely abide by the criteria set out in this standard together with the requirements mentioned in the referenced documentation.

2.6 Process for monitoring

This document will be reviewed once every five years.

2.7 Related/Supporting Documents

See Section 2.2

3. Requirements

3.1 General

- 3.1.1 Nothing in this standard shall lessen the obligations of the supplier detailed in any other specifications or documents forming part of the order.
- 3.1.2 The supplier shall be responsible for all aspects of quality, relating to manufacture, handling, packaging and possible transportation of his product.
- 3.1.3 Eskom will provide the technical details for the required conductors as per Schedule A in **ANNEXURE A**. The Supplier shall provide the details of the conductor offered in Schedule B. Any deviation from the requirements shall be entered separately in a deviation schedule/sheet.
- 3.1.4 Handling and storage of all conductor drums once received by the contractor must adhere to guidelines as specified in latest revision of 240-47172520 (*TRMSCAAC5.2*).
- 3.1.5 The requester of the various commodities listed in this document must ensure that the relevant internal Eskom processes are adhered to when placing orders.
- 3.1.6 It is the responsibility of the manufacturer to submit all relevant Quality Inspection Test Plans (QITP) and specific project quality documents to Eskom before production of any batch begins. These quality documents will be used by Eskom to monitor the final product quality before release is done from the factory.

3.2 Standard Drum Sizes

- 3.2.1 For non-returnable wooden drums, **ANNEXURE C** provides guidelines on the typical dimensions to which the drums must conform. Drum sizes for conductors not mentioned in the table, must be designed to satisfy the bending factor criteria. These designs must be submitted to Eskom for approval before production starts. Current drums used for existing conductors supplied to Eskom may be used for conductors not listed in the table in **ANNEXURE C**. The main criteria for the drum design is that the spindle size must have an inside diameter of 92 mm. Where drum lengths that are requested for supply either differ or are non-standard for conductors that are shown in **ANNEXURE C**, the supplier must indicate if, and if requested to, show via submitted drum designs that, the new total length and drum size are acceptable for drumming and supply according to bending factor and spindle size criteria.

3.3 Fabrication

- 3.3.1 Each wire shall be marked with two uniform longitudinal indentations, situated 180° opposed, along its entire length. A deviation angle of 5 to 15 degrees below 180° shall be allowed to ensure proper contact between indent ring and wire. The dimension of the indent mark shall be 0.3 mm wide and the groove depth from 0.15 mm down to 0.11 mm. The marking rollers shall undergo periodic dimension checking to ensure that the marking groove dimensions are within the specified limits (**ANNEXURE B**). The indentations shall be performed after the wire drawing process, but before stranding. The indentations shall be clearly visible and shall not affect the original wire characteristics, distort the wire roundness or leave any sharp protrusions. The marking is protected by patent laws and shall therefore be unique to and accepted by Eskom, prior to the first production run.
- 3.3.2 The location of all welds in individual aluminium wires shall be recorded. Copies of these records must be forwarded to Eskom at the time of conductor dispatch.
- 3.3.3 Notwithstanding clause 5.5 of SANS 61089,
- There shall be no joints in any individual wire of a steel core containing less than seven wires.
 - Joints in individual wires of a steel core containing seven wires or more shall be permitted, provided that
 - No two such joints are less than 15 m apart;

ESKOM COPYRIGHT PROTECTED

- Each joint is made by resistance butt welding and is protected against corrosion by re-galvanizing; and
- The diameter of the stranded core is not increased materially by the joint.

3.3.4 The wire must be stranded so that the conductor is essentially free from the tendency to untwist or spring apart when cut.

3.3.5 The completed conductor shall be uniformly cylindrical and shall be capable of withstanding normal handling during manufacturing, transportation, and installing without being deformed from its cylindrical form in such a way as to increase corona losses and radio interference.

3.3.6 When specified in the schedule of requirements, the core and the inner layers of aluminium shall be greased only with only an approved grease (refer to technical bulletin 13TB-015), certified and tested in accordance with IEC 61394. The test certificate of the grease to be used shall be supplied with the tender.

3.3.7 The method of application of the grease shall be as per IEC 61089 Case 2 for conductors with three or more layers and as per IEC 61089 Case 4 for two layers or a single layer conductor, or as otherwise specified by the client in writing. Grease shall be uniformly applied by a method approved by Eskom. All aspects of manufacture and delivery of greased conductors shall be completed in such a manner that grease is not displaced toward the outer surface of the conductors. The greased conductor shall be delivered as specified above. Incorrectly greased conductor will not be accepted by Eskom and shall be replaced by the supplier unless otherwise stated. All AAAC conductors shall be greased.

3.3.8 The conductor linear masses quoted in the schedules are for ungreased conductors. The supplier must provide the mass for greased conductors.

3.4 Matched set requirements

3.4.1 Matched sets of conductors shall be furnished in lengths given in schedule A. Matched pairs shall be manufactured from a single length of steel core. Matched sets of four and six conductors shall consist of two or three matched pairs respectively. All the core wire for the matched set shall be produced from steel wires drawn from billets produced from one cast or heat.

3.4.2 All lengths of steel core used for a matched set shall be produced on the same stranding machine. Each drum of the matched set of conductors shall be produced on the same stranding machine. Lay gears and tooling set up, shall remain constant for each production run. Lay ratios shall not vary by more than 5 % over the entire order from a specific supplier.

3.4.3 The mass of the conductor, per unit length without grease, shall not vary from its nominal value given by the supplier of the conductor to the client and accepted by the client in the relevant schedule B in ANNEXURE A, by more than ± 2 %.

3.5 Lay Ratios

Lay ratios shall be in accordance with SANS 61089 if not specified otherwise.

3.6 Length

3.6.1 The length of conductor on a drum shall not vary by more than +2 % and 0 % from the nominal length.

3.6.2 The variation in length between conductors forming a matched set shall not exceed 20 m. Only one continuous length of conductor per drum shall be permitted. The accuracy of measurement shall be ± 0.5 %.

3.7 Conductor Marking

3.7.1 Only marked conductors shall be used in Eskom projects. Marked conductors shall be obtained only from Eskom approved suppliers. Eskom will provide tenderers for contracted projects with the list of approved suppliers. The tender enquiry will clearly indicate the details of free issue conductor when Eskom wishes to provide marked conductors or for the tenderer to procure marked conductors from an approved supplier, on behalf of Eskom. Eskom will maintain ownership of the marked conductors at all times. Conductor suppliers may sell marked conductors only to those contractors who can prove that they will be used on Eskom projects. Eskom will provide those contractors with the necessary proof, indicating the name of the project and the quantities required. The contractor must obtain the letter of proof from Eskom Group Procurement. The contractor shall arrange for the return of unused, waste and off-cuts of marked conductors to Eskom.

4. Test Requirement

4.1.1 Type, sample production and routine production tests shall be carried out by the supplier, and shall be submitted to Eskom within 14 days before production of full consignment commences when required or requested.

4.1.2 A complete set of conductor type tests certificates, in accordance with SANS 61089, must be submitted for at least one conductor per design type at tender stage. This set of type tests will qualify the design range at tender stage. Before a conductor is supplied to Eskom, a full set of type tests for the conductor must be submitted. Type test reports must include full sample test data and manufacturing equipment details, e.g. stranding machine details. Manufacturers must be aware that if any aspect of the conductor production changes a new type test is required, e.g. new manufacturing equipment, conductor lay ratios, new raw materials suppliers and production changes.

4.1.3 A list of typical tests as specified in SANS 61089 is included below, this list is subject to change, and not limited to the following, as required by Eskom and updates to SANS 61089.

- Type tests
 - Joint in aluminium wires
 - Stress-strain curves
 - Breaking strength of conductor (tensile test of conductor)
- Sample tests
 - On wire before stranding
 - As per the applicable wire standards
 - On the conductor
 - Cross-sectional area
 - Overall diameter
 - Linear density
 - Surface condition
 - Lay ratio and direction of lay
 - Breaking strength of wires
- Sample size
- Sample length
- Welding of aluminium wires

4.1.4 The tenderer shall provide Eskom with an estimate of the creep each conductor can expect over a 20-year lifespan when required. The estimate must be given with full details of the calculation thereof.

ESKOM COPYRIGHT PROTECTED

- 4.1.5** All conductors which deviate from the specification or these schedules will be rejected. Should deviations from the specification be unavoidable, written acceptance of those deviations shall be obtained from Eskom.
- 4.1.6** Test certificates showing results of production routine tests, shall be retained by the supplier for a minimum of five years, whereas test certificates showing results of type tests shall be retained on permanent record by the supplier, for Eskom's inspection.
- 4.1.7** For release of any consignment of conductor required by Eskom it is required that the full sample/production test results be available for review by the Eskom Quality Representative. There may be additional samples tested by the Eskom Quality Representative to verify the consignment being released.
- 4.1.8** The tests listed below must be conducted according to *Cispr 18-2* for when requested by Eskom. Additional tests when requested by Eskom shall be done by the supplier.
- Determine corona inception gradient in kV/cm for a single conductor (using RIV measurement method)
 - Record the ambient parameters which define relative air density (ambient temp, humidity etc.)
- 4.1.9** For the resistivity type test, a resistance value per metre of the produced conductor is to be provided. Resistivity values are also required for each material type (e.g. steel, copper, aluminium alloy), used to make up the complete conductor. Resistance per conductor type is to be provided in per unit length where requested.

5. Packing and marking requirements

5.1 Drums

- 5.1.1** All conductors shall be supplied on returnable steel drums or non-returnable wooden drums as specified in Schedule A.
- 5.1.2** For multi-layered construction the conductor shall be wound onto the drums to form complete layers. Each layer shall fill the width of the drum before the succeeding layer is wound on. Drums not wound in this manner will be rejected. Conductor drums where conductors are damaged when taken off the drum due to an incorrectly wound conductor shall be replaced by the manufacturer.
- 5.1.3** An acceptable method of holding the conductor end shall be used, to ensure that no relative movement of conductor occurs between the uppermost uncompleted layer and the completed layer directly below it, during transportation. Details of the proposed holding method shall accompany the tender offer, and shall be subject to Eskom's approval.
- 5.1.4** Wood lagging shall be used to protect the conductor. Four steel straps shall be used to secure the lagging on steel drums. Wooden lagging should be uniformly spaced with at most 10mm spacing between adjacent laggings. The battens shall be nailed to the flanges of wooden drums and two steel band straps shall be provided around each drum to prevent easy removal of the battens. The length of the nails used shall be at least 10 mm less than the distance from the outside of the battens to the top of the conductor on the drum. Care shall be taken to prevent the nails from protruding through the surface of the flange. No component of the drum shall cause damage to the conductor at any time.
- 5.1.5** Heavy weatherproof paper, cardboard or other suitable material shall be placed between the conductor and barrel and flange surfaces of steel drums. This material shall remain attached to the drum during unreeling.
- 5.1.6** Imported conductor shall have weatherproof material inserted between the two outermost layers of conductor and wrapped over the outermost layer. The supplier of imported conductors must arrange the arrival dates and times of shipments with Eskom Distribution Quality Assurance so that the conductor can be land-tested before it is released.
- 5.1.7** The moisture content of wood used for the fabrication of drums and reels shall not exceed 150 g/kg (15 %).

ESKOM COPYRIGHT PROTECTED

-
- 5.1.8** Wooden drums shall be preserved from insect attack and mould by adopting either the **Heat Treatment (Kiln drying-CPI indicated by HT) or by Methyl Bromide Fumigation (indicated by MB)**. At the time of compiling this document these were the acceptable preservation methods. Further information on this can be sourced from the South African Department of Agriculture (reference document *ISPM 15 – GUIDELINES FOR REGULATING WOOD PACKAGING MATERIAL IN INTERNATIONAL TRADE*). The preservative used shall not react with the metal of the conductor.
- 5.1.9** Conductor travelling by ship shall have a waterproof plastic or canvas material inserted between the outer most layers of conductor and wrapped over the outermost layer.
- 5.1.10** Where requested, the supplier is to include a modified drum that is either a hybrid or made completely of steel. The design and request of a specialised drum will be finalised on a project by project basis.
- 5.1.11** All drums must be as ergonomically designed as possible to allow for efficiency and comfort of use in the work environment. Where possible and economically acceptable, upgrades and changes to drums must be included as part of the project if requested.

5.2 Drum Marking

Further to Clause 7.2 of IEC 61089 and Eskom's General Conditions of Purchase, the following requirements shall also be met:

- 5.2.1** The drums for a matched set of conductors shall be marked:
- 1A and 1B for matched pairs;
 - 1A, 1B and 1C for matched triple sets, etc.
 - This marking must be on both flanges of the drum.
- 5.2.2** The actual measured length and nett mass of conductor shall be marked on each drum in black stencilled lettering of 50mm height on the drum side. Other markings on drums must include the following:
- Matched sets to be marked
 - Measured length
 - Nett mass
 - Gross mass
 - Order number
 - Conductor type
 - Greased or non-greased
 - Eskom Logo and signature
 - Red dot
 - Drum rolling direction
- 5.2.3** Drums of greased conductor shall be marked "Greased with (the product name)".
- 5.2.4** All drum marking pertaining to a previous order shall be painted over or otherwise satisfactorily obliterated.
- 5.2.5** All conductor drums destined for Eskom projects shall be branded with Eskom signature (logo and logotype) on one of its flat sides (the flange).
- 5.2.6** The Eskom signature shall be printed in Eskom Blue or Black only on the white-coloured background.

- 5.2.7** For metal drums and wooden drums, a portion of the flange surface shall be painted in white to provide rectangular background on which the signature shall be printed in Eskom Blue or Black only. The width (or height) of the white rectangular background shall be three times the diameter of the “circle” part of the Eskom signature. The printed Eskom signature shall appear central onto the white rectangular background leaving a space equal to one signature “circle” on both front and back ends.
- 5.2.8** The Eskom logo printing shall be made by stencilling; taking care to complete continuous character “O” in the name Eskom. Other equivalent techniques can be used, once approved by Eskom.
- 5.2.9** The dimensions of complete Eskom signatures shall be a minimum length and width (height) of 82 mm and 21 mm respectively. All other printing on the flange shall be positioned so as to ensure a minimum clearance of one logo “circle” diameter away from the Eskom signature. An example of a drum with the Eskom signature and standard printing guidelines are shown in **ANNEXURE D**.
- 5.2.10** Red Round Mark: The Opposite end of a conductor drum (not bearing the Eskom logo) shall be marked (stamped) with a red circle of 200 mm diameter to augment the logo for forensic purposes.
- 5.2.11** A label detailing handling/storing requirements must be attached onto one side of the drum which will inform contractors of how to take care of drums and conductors. The size of label should be approximately 0.4 m x 0.4 m of drum. As a minimum label should state “Remove all protruding nails near conductor on flanges before conductor is used for stringing; ensure conductor never touches the bare ground; spreader bar must be used for lifting of drums, follow arrow on drum for rolling direction” etc.

5.3 Additional notes

Not applicable.

6. Authorisation

This document has been seen and accepted by:

Name and surname	Designation
Riaz Vajeth	Line Engineering Services - Senior Manager
Bharat Haridass	Line Engineering Services - Senior Consultant
Ravi Singh	Line Engineering Services - Chief Engineer

7. Revisions

Date	Rev	Compiler	Remarks
March 2021	2	P. Mathuradas	Revision changes due to comments received. Included table in Annex C.
Aug 2020	1	P Mathuradas	New document, this document supersedes the following documents: TSP 41-264, DSP 34-377 and 240-75521456

8. Development team

The following people were involved in the development of this document:

- Riaz Vajeth Line Engineering Services
- Ravi Singh Line Engineering Services
- Bharat Haridass Line Engineering Services
- Arthur Burger Line Engineering Services

ESKOM COPYRIGHT PROTECTED

- Prashant Mathuradas Line Engineering Services
- Shawn Ramadhin Line Engineering Services

9. Acknowledgements

Comments received from the following people:

- Sydwell Makhaye
- Mohamed Khan
- A.M. Gouws
- Boreman Risiva
- Kiresh Singh
- Tumisang (Lebo) Maphumulo

Annex A – Example of Technical Schedule A and B**Squirrel ACSR conductor****ALTERNATIVE phase conductor**

- Resistance (Ohms/km) ≤ 1.3677
- Conductor diameter (mm) ≈ 6.33
- Ultimate Tensile Strength (kN) ≥ 8.02
- Conductor linear mass (kg/km)- ungreased value ≈ 85.2
- Modulus of elasticity final (MPa) ≈ 80400
- Coefficient of linear expansion, β , ($1/^\circ\text{C}$) $\approx 19.31 * 10^{-6}$

A/B SCHEDULES phase conductor Specification Sheets**Schedule A: Purchaser's specific requirements****Schedule B: Particulars of equipment to be supplied****Conductor Type**

Description	Schedule A	Schedule B
IEC Code	20.98-A1/S1A-6/1/2.11	
Conductor Overall Diameter (mm)	6.33	
Area Aluminium (mm ²)	20.98	
Area Total (mm ²)	24.48	
Aluminium wires (number off) / (diameter mm)	6/2.11	
Steel wires (number off) / (diameter mm)	1/2.11	
Conductor linear mass (kg/km)- ungreased value	85.2	
Ultimate Tensile Strength (kN)	8.02	
Resistance DC @ 20°C (Ohms/km)	1.3677	
Modulus Elasticity Final (MPa)	80400	
Coefficient of Linear Expansion, β , ($1/^\circ\text{C}$)	19.31 * 10-6	
Drum Length (m)	3000	
Matched Sets	No	
Greased (As specified in 13TB-015. Equivalent products subject to Eskom's approval.)	Greased and ungreased	

ESKOM COPYRIGHT PROTECTED

Magpie ACSR conductor

ALTERNATIVE phase conductor

If an alternative conductor is offered, the following electrical and mechanical properties shall be observed:

- Resistance (Ohms/km) ≤ 2.707
- Conductor diameter (mm) ≈ 6.35
- Ultimate Tensile Strength (kN) ≥ 18.573
- Conductor linear mass (kg/km)- ungreased value ≈ 139.7
- Modulus of elasticity final (MPa) ≈ 133760
- Coefficient of linear expansion, β , (1/°C) $\approx 13.68 \times 10^{-6}$

A/B SCHEDULES phase conductor Specification Sheets

Schedule A: Purchaser's specific requirements

Schedule B: Particulars of equipment to be supplied

Conductor Type

Description	Schedule A	Schedule B
IEC Code	10.58-A1/S1A-3/2.12-4/2.12	
Conductor Overall Diameter (mm)	6.35	
Area Aluminium (mm ²)	10.58	
Area Total (mm ²)	24.71	
Aluminium wires (number off) / (diameter mm)	3/2.12	
Steel wires (number off) / (diameter mm)	4/2.12	
Conductor linear mass (kg/km)- ungreased value	139.7	
Ultimate Tensile Strength (kN)	18.573	
Resistance DC @ 20°C (Ohms/km)	2.707	
Modulus Elasticity Final (MPa)	133760	
Coefficient of Linear Expansion, β , (1/°C)	13.68 * 10-6	
Drum Length (m)	3000	
Matched Sets	No	
Greased (As specified in 13TB-015. Equivalent products subject to Eskom's approval.).	Greased and ungreased	

Fox ACSR conductor

ALTERNATIVE phase conductor

If an alternative conductor is offered, the following electrical and mechanical properties shall be observed:

- Resistance (Ohms/km) ≤ 0.7822
- Conductor diameter (mm) ≈ 8.37
- Ultimate Tensile Strength (kN) ≥ 13.1
- Conductor linear mass (kg/km)- ungreased value ≈ 149
- Modulus of elasticity final (MPa) ≈ 80400
- Coefficient of linear expansion, β , (1/°C) $\approx 19.31 * 10^{-6}$

A/B SCHEDULES phase conductor Specification Sheets

Schedule A: Purchaser's specific requirements

Schedule B: Particulars of equipment to be supplied

Conductor Type

Description	Schedule A	Schedule B
IEC Code	36.68-A1/S1A-6/1/2.79	
Conductor Overall Diameter (mm)	8.37	
Area Aluminium (mm ²)	36.68	
Area Total (mm ²)	42.8	
Aluminium wires (number off) / (diameter mm)	6/2.79	
Steel wires (number off) / (diameter mm)	1/2.79	
Conductor linear mass (kg/km)- ungreased value	149	
Ultimate Tensile Strength (kN)	13.1	
Resistance DC @ 20°C (Ohms/km)	0.7822	
Modulus Elasticity Final (MPa)	80400	
Coefficient of Linear Expansion, β , (1/°C)	19.31 * 10-6	
Drum Length (m)	1500	
Matched Sets	No	
Greased (As specified in 13TB-015. Equivalent products subject to Eskom's approval.).	Greased and ungreased	

Mink ACSR conductor

ALTERNATIVE phase conductor

If an alternative conductor is offered, the following electrical and mechanical properties shall be observed:

- Resistance (Ohms/km) ≤ 0.4546
- Conductor diameter (mm) ≈ 10.98
- Ultimate Tensile Strength (kN) ≥ 21.9
- Conductor linear mass (kg/km)- ungreased value ≈ 257
- Modulus of elasticity final (MPa) ≈ 80400
- Coefficient of linear expansion, β , (1/°C) $\approx 19.31 * 10^{-6}$

A/B SCHEDULES phase conductor Specification Sheets

Schedule A: Purchaser's specific requirements

Schedule B: Particulars of equipment to be supplied

Conductor Type

Description	Schedule A	Schedule B
IEC Code	63.13-A1/S1A-6/1/3.66	
Conductor Overall Diameter (mm)	10.98	
Area Aluminium (mm ²)	63.13	
Area Total (mm ²)	73.65	
Aluminium wires (number off) / (diameter mm)	6/3.66	
Steel wires (number off) / (diameter mm)	1/3.66	
Conductor linear mass (kg/km)- ungreased value	257	
Ultimate Tensile Strength (kN)	21.9	
Resistance DC @ 20°C (Ohms/km)	0.4546	
Modulus Elasticity Final (MPa)	80400	
Coefficient of Linear Expansion, β , (1/°C)	19.31 * 10-6	
Drum Length (m)	1500	
Matched Sets	No	
Greased (As specified in 13TB-015. Equivalent products subject to Eskom's approval.).	Greased and ungreased	

Horse ACSR conductor

ALTERNATIVE phase conductor

If an alternative conductor is offered, the following electrical and mechanical properties shall be observed:

- Resistance (Ohms/km) ≤ 0.3939
- Conductor diameter (mm) ≈ 13.95
- Ultimate Tensile Strength (kN) ≥ 60.7
- Conductor linear mass (kg/km)- ungreased value ≈ 541
- Modulus of elasticity final (MPa) ≈ 108000
- Coefficient of linear expansion, β , ($1/^\circ\text{C}$) $\approx 15.84 \times 10^{-6}$

A/B SCHEDULES phase conductor Specification Sheets

Schedule A: Purchaser's specific requirements

Schedule B: Particulars of equipment to be supplied

Conductor Type

Description	Schedule A	Schedule B
IEC Code	IEC Code 73.36-A1/S1A-12/7/2.79	
Conductor Overall Diameter (mm)	13.95	
Area Aluminium (mm ²)	73.36	
Area Total (mm ²)	116.16	
Aluminium wires (number off) / (diameter mm)	12/2.79	
Steel wires (number off) / (diameter mm)	7/2.79	
Conductor linear mass (kg/km)- ungreased value	541	
Ultimate Tensile Strength (kN)	60.7	
Resistance DC @ 20°C (Ohms/km)	0.3939	
Modulus Elasticity Final (MPa)	108000	
Coefficient of Linear Expansion, β , ($1/^\circ\text{C}$)	15.84×10^{-6}	
Drum Length (m)	2000	
Matched Sets	No	
Greased (As specified in 13TB-015. Equivalent products subject to Eskom's approval.).	Greased and ungreased	

Hare ACSR conductor

ALTERNATIVE phase conductor

If an alternative conductor is offered, the following electrical and mechanical properties shall be observed:

- Resistance (Ohms/km) ≤ 0.2733
- Conductor diameter (mm) ≈ 14.16
- Ultimate Tensile Strength (kN) ≥ 36
- Conductor linear mass (kg/km)- ungreased value ≈ 427
- Modulus of elasticity final (MPa) ≈ 80400
- Coefficient of linear expansion, β , (1/°C) $\approx 19.31 * 10^{-6}$

A/B SCHEDULES phase conductor Specification Sheets

Schedule A: Purchaser's specific requirements

Schedule B: Particulars of equipment to be supplied

Conductor Type

Description	Schedule A	Schedule B
IEC Code	IEC Code 104.98-A1/S1A-6/1/4.72	
Conductor Overall Diameter (mm)	14.16	
Area Aluminium (mm ²)	104.98	
Area Total (mm ²)	122.48	
Aluminium wires (number off) / (diameter mm)	6/4.72	
Steel wires (number off) / (diameter mm)	1/4.72	
Conductor linear mass (kg/km)- ungreased value	427	
Ultimate Tensile Strength (kN)	36	
Resistance DC @ 20°C (Ohms/km)	0.2733	
Modulus Elasticity Final (MPa)	80400	
Coefficient of Linear Expansion, β , (1/°C)	19.31 * 10-6	
Drum Length (m)	1500	
Matched Sets	No	
Greased (As specified in 13TB-015. Equivalent products subject to Eskom's approval.).	Greased and ungreased	

Tiger ACSR conductor

ALTERNATIVE PHASE CONDUCTOR

If an alternative conductor is offered, the following electrical and mechanical properties shall be observed:

- Resistance (Ohms/km) ≤ 0.2202
- Conductor diameter (mm) ≈ 16.52
- Ultimate Tensile Strength (kN) ≥ 58.70
- Conductor linear mass (kg/km)- ungreased value ≈ 606
- Modulus of elasticity final (MPa) ≈ 83400
- Coefficient of linear expansion, β , ($1/^\circ\text{C}$) $\approx 18.43 * 10^{-6}$

A/B SCHEDULES PHASE CONDUCTOR SPECIFICATION SHEETS

Schedule A: Purchaser's specific requirements

Schedule B: Particulars of equipment to be supplied

Conductor Type

Description	Schedule A	Schedule B
IEC Code	131.23-A1/S1A-30/7/2.36	
Conductor Overall Diameter (mm)	16.52	
Area Aluminium (mm ²)	131.23	
Area Total (mm ²)	161.85	
Aluminium wires (number off) / (diameter mm)	30/2.36	
Steel wires (number off) / (diameter mm)	7/2.36	
Conductor linear mass (kg/km)- ungreased value	606	
Ultimate Tensile Strength (kN)	58.70	
Resistance DC @ 20°C (Ohms/km)	0.2202	
Modulus Elasticity Final (MPa)	83400	
Coefficient of Linear Expansion, β , ($1/^\circ\text{C}$)	$18.43 * 10^{-6}$	
Drum Length (m)	2000	
Matched Sets	Yes	
Greased (As specified in 13TB-015. Equivalent products subject to Eskom's approval.).	Greased and ungreased.	

Oden ACSR conductor

ALTERNATIVE phase conductor

If an alternative conductor is offered, the following electrical and mechanical properties shall be observed:

- Resistance (Ohms/km) ≤ 0.23
- Conductor diameter (mm) ≈ 17.6
- Ultimate Tensile Strength (kN) ≥ 102.75
- Conductor linear mass (kg/km)- ungreased value ≈ 860
- Modulus of elasticity final (MPa) ≈ 108000
- Coefficient of linear expansion, β , (1/°C) $\approx 15.84 \times 10^{-6}$

A/B SCHEDULES phase conductor Specification Sheets

Schedule A: Purchaser's specific requirements

Schedule B: Particulars of equipment to be supplied

Conductor Type

Description	Schedule A	Schedule B
IEC Code	117-A1/S1A-12/7/3.52	
Conductor Overall Diameter (mm)	17.6	
Area Aluminium (mm ²)	117	
Area Total (mm ²)	185	
Aluminium wires (number off) / (diameter mm)	12/3.52	
Steel wires (number off) / (diameter mm)	7/3.52	
Conductor linear mass (kg/km)- ungreased value	860	
Ultimate Tensile Strength (kN)	102.75	
Resistance DC @ 20°C (Ohms/km)	0.23	
Modulus Elasticity Final (MPa)	108000	
Coefficient of Linear Expansion, β , (1/°C)	15.84* 10-6	
Drum Length (m)	1500	
Matched Sets	Yes	
Greased (As specified in 13TB-015. Equivalent products subject to Eskom's approval.).	Greased and Ungreased.	

Wolf ACSR conductor

ALTERNATIVE phase conductor

If an alternative conductor is offered, the following electrical and mechanical properties shall be observed:

- Resistance (Ohms/km) ≤ 0.1828
- Conductor diameter (mm) ≈ 18.13
- Ultimate Tensile Strength (kN) ≥ 69.2
- Conductor linear mass (kg/km)- ungreased value ≈ 730
- Modulus of elasticity final (MPa) ≈ 83400
- Coefficient of linear expansion, β , (1/°C) $\approx 18.43 \times 10^{-6}$

A/B SCHEDULES phase conductor Specification Sheets

Schedule A: Purchaser's specific requirements

Schedule B: Particulars of equipment to be supplied

Conductor Type

Description	Schedule A	Schedule B
IEC Code	IEC Code 158.06-A1/S1A-30/7/2.59	
Conductor Overall Diameter (mm)	18.13	
Area Aluminium (mm ²)	158.06	
Area Total (mm ²)	194.94	
Aluminium wires (number off) / (diameter mm)	30/2.59	
Steel wires (number off) / (diameter mm)	7/2.59	
Conductor linear mass (kg/km)- ungreased value	730	
Ultimate Tensile Strength (kN)	69.2	
Resistance DC @ 20°C (Ohms/km)	0.1828	
Modulus Elasticity Final (MPa)	83400	
Coefficient of Linear Expansion, β , (1/°C)	18.43 * 10-6	
Drum Length (m)	1500	
Matched Sets	Yes	
Greased (As specified in 13TB-015. Equivalent products subject to Eskom's approval.).	Greased and ungreased	

Chickadee ACSR conductor

ALTERNATIVE phase conductor

If an alternative conductor is offered, the following electrical and mechanical properties shall be observed:

- Resistance (Ohms/km) ≤ 0.1427
- Conductor diameter (mm) ≈ 18.87
- Ultimate Tensile Strength (kN) ≥ 44.9
- Conductor linear mass (kg/km)- ungreased value ≈ 643
- Modulus of elasticity final (MPa) ≈ 66200
- Coefficient of linear expansion, β , (1/°C) $\approx 21.44 * 10^{-6}$

A/B SCHEDULES phase conductor Specification Sheets

Schedule A: Purchaser’s specific requirements

Schedule B: Particulars of equipment to be supplied

Conductor Type

Description	Schedule A	Schedule B
IEC Code	200.93-A1/S1A-18/1/3.77	
Conductor Overall Diameter (mm)	18.87	
Area Aluminium (mm ²)	200.93	
Area Total (mm ²)	212.09	
Aluminium wires (number off) / (diameter mm)	18/3.77	
Steel wires (number off) / (diameter mm)	1/3.77	
Conductor linear mass (kg/km)- ungreased value	643	
Ultimate Tensile Strength (kN)	44.9	
Resistance DC @ 20°C (Ohms/km)	0.1427	
Modulus Elasticity Final (MPa)	66200	
Coefficient of Linear Expansion, β , (1/°C)	21.44 * 10-6	
Drum Length (m)	3000	
Matched Sets	Yes	
Greased (As specified in 13TB-015. Equivalent products subject to Eskom’s approval.).	Greased and ungreased	

Panther ACSR conductor

ALTERNATIVE PHASE CONDUCTOR

If an alternative conductor is offered, the following electrical and mechanical properties shall be observed:

- Resistance (Ohms/km) ≤ 0.1363
- Conductor diameter (mm) ≈ 21.00
- Ultimate Tensile Strength (kN) ≥ 90.80
- Conductor linear mass (kg/km)- ungreased value ≈ 970
- Modulus of elasticity final (MPa) ≈ 83400
- Coefficient of linear expansion, β , (1/°C) $\approx 18.43 * 10^{-6}$

A/B SCHEDULES PHASE CONDUCTOR SPECIFICATION SHEETS

Schedule A: Purchaser's specific requirements

Schedule B: Particulars of equipment to be supplied

Conductor Type

Description	Schedule A	Schedule B
IEC Code	212.06-A1/S1A-30/7/3.00	
Conductor Overall Diameter (mm)	21.00	
Area Aluminium (mm ²)	212.06	
Area Total (mm ²)	261.54	
Aluminium wires (number off) / (diameter mm)	30/3.00	
Steel wires (number off) / (diameter mm)	7/3.00	
Conductor linear mass (kg/km)- ungreased value	970	
Ultimate Tensile Strength (kN)	90.80	
Resistance DC @ 20°C (Ohms/km)	0.1363	
Modulus Elasticity Final (MPa)	83400	
Coefficient of Linear Expansion, β , (1/°C)	18.43 * 10 ⁻⁶	
Drum Length (m)	3000	
Matched Sets	Yes	
Greased (As specified in 13TB-015. Equivalent products subject to Eskom's approval.).	Greased and ungreased.	

Bear ACSR conductor

ALTERNATIVE phase conductor

If an alternative conductor is offered, the following electrical and mechanical properties shall be observed:

- Resistance (Ohms/km) ≤ 0.1093
- Conductor diameter (mm) ≈ 23.45
- Ultimate Tensile Strength (kN) ≥ 112
- Conductor linear mass (kg/km)- ungreased value ≈ 1220
- Modulus of elasticity final (MPa) ≈ 83400
- Coefficient of linear expansion, β , (1/°C) $\approx 18.43 \times 10^{-6}$

A/B SCHEDULES phase conductor Specification Sheets

Schedule A: Purchaser's specific requirements

Schedule B: Particulars of equipment to be supplied

Conductor Type

Description	Schedule A	Schedule B
IEC Code	IEC Code 264.42-A1/S1A-30/7/3.35	
Conductor Overall Diameter (mm)	23.45	
Area Aluminium (mm ²)	264.42	
Area Total (mm ²)	326.12	
Aluminium wires (number off) / (diameter mm)	30/3.35	
Steel wires (number off) / (diameter mm)	7/3.35	
Conductor linear mass (kg/km)- ungreased value	1220	
Ultimate Tensile Strength (kN)	112	
Resistance DC @ 20°C (Ohms/km)	0.1093	
Modulus Elasticity Final (MPa)	83400	
Coefficient of Linear Expansion, β , (1/°C)	18.43 * 10-6	
Drum Length (m)	1500	
Matched Sets	Yes	
Greased (As specified in 13TB-015. Equivalent products subject to Eskom's approval.).	Greased and ungreased	

Kingbird ACSR conductor

ALTERNATIVE PHASE CONDUCTOR

If an alternative conductor is offered, the following electrical and mechanical properties shall be observed:

- Resistance (Ohms/km) $\leq 0,0891$
- Conductor diameter (mm) ≈ 23.90
- Ultimate Tensile Strength (kN) ≥ 71.32
- Conductor linear mass (kg/km)- ungreased value ≈ 1038
- Modulus of elasticity final (MPa) ≈ 66200
- Coefficient of linear expansion, β , (1/°C) $\approx 21.69 * 10^{-6}$

A/B SCHEDULES PHASE CONDUCTOR SPECIFICATION SHEETS

Schedule A: Purchaser's specific requirements

Schedule B: Particulars of equipment to be supplied

Conductor Type

Description	Schedule A	Schedule B
IEC Code	323.01-A1/S1A-18/1/4.78	
Conductor Overall Diameter (mm)	23.90	
Area Aluminium (mm ²)	323.01	
Area Total (mm ²)	340.96	
Aluminium wires (number off) / (diameter mm)	18/4.78	
Steel wires (number off) / (diameter mm)	1/4.78	
Conductor linear mass (kg/km)- ungreased value	1038	
Ultimate Tensile Strength (kN)	71.32	
Resistance DC @ 20°C (Ohms/km)	0,0891	
Modulus Elasticity Final (MPa)	66200	
Coefficient of Linear Expansion, β , (1/°C)	$21.69 * 10^{-6}$	
Drum Length (m)	1500	
Matched Sets	Yes	
Greased (As specified in 13TB-015. Equivalent products subject to Eskom's approval.).	Greased and ungreased.	

IEC 315 ACSR conductor

ALTERNATIVE PHASE CONDUCTOR

If an alternative conductor is offered, the following electrical and mechanical properties shall be observed:

- Resistance (Ohms/km) $\leq 0,0917$
- Conductor diameter (mm) ≈ 23.9
- Ultimate Tensile Strength (kN) ≥ 79.03
- Conductor linear mass (kg/km)- ungreased value ≈ 1039.6

A/B SCHEDULES PHASE CONDUCTOR SPECIFICATION SHEETS

Schedule A: Purchaser's specific requirements

Schedule B: Particulars of equipment to be supplied

Conductor Type

Description	Schedule A	Schedule B
IEC Code	315-A1/S1A-45/2.99-7/1.99	
Conductor Overall Diameter (mm)	23.9	
Area Aluminium (mm ²)	315	
Area Total (mm ²)	337	
Aluminium wires (number off) / (diameter mm)	45/2.99	
Steel wires (number off) / (diameter mm)	7/1.99	
Conductor linear mass (kg/km)- ungreased value	1039.6	
Ultimate Tensile Strength (kN)	79.03	
Resistance DC @ 20°C (Ohms/km)	0,0917	
Modulus Elasticity Final (MPa)	Supplier to specify	
Coefficient of Linear Expansion, β , (1/°C)	Supplier to specify	
Drum Length (m)	3000	
Matched Sets	Yes	
Greased (As specified in 13TB-015. Equivalent products subject to Eskom's approval.)	Greased and ungreased.	

Goat ACSR conductor

ALTERNATIVE phase conductor

If an alternative conductor is offered, the following electrical and mechanical properties shall be observed:

- Resistance (Ohms/km) ≤ 0.0891
- Conductor diameter (mm) ≈ 25.97
- Ultimate Tensile Strength (kN) ≥ 136
- Conductor linear mass (kg/km)- ungreased value ≈ 1500
- Modulus of elasticity final (MPa) ≈ 83400
- Coefficient of linear expansion, β , (1/°C) $\approx 18.43 \times 10^{-6}$

A/B SCHEDULES phase conductor Specification Sheets

Schedule A: Purchaser's specific requirements

Schedule B: Particulars of equipment to be supplied

Conductor Type

Description	Schedule A	Schedule B
IEC Code	IEC Code 324.31-A1/S1A-30/7/3.71	
Conductor Overall Diameter (mm)	25.97	
Area Aluminium (mm ²)	324.31	
Area Total (mm ²)	399.98	
Aluminium wires (number off) / (diameter mm)	30/3.71	
Steel wires (number off) / (diameter mm)	7/3.71	
Conductor linear mass (kg/km)- ungreased value	1500	
Ultimate Tensile Strength (kN)	136	
Resistance DC @ 20°C (Ohms/km)	0.0891	
Modulus Elasticity Final (MPa)	83400	
Coefficient of Linear Expansion, β , (1/°C)	18.43 * 10-6	
Drum Length (m)	3000	
Matched Sets	Yes	
Greased (As specified in 13TB-015. Equivalent products subject to Eskom's approval.).	Greased and ungreased	

Tern ACSR conductor

ALTERNATIVE PHASE CONDUCTOR

If an alternative conductor is offered, the following electrical and mechanical properties shall be observed:

- Resistance (Ohms/km) $\leq 0,0718$
- Conductor diameter (mm) ≈ 27.00
- Ultimate Tensile Strength (kN) ≥ 98.70
- Conductor linear mass (kg/km)- ungreased value ≈ 1340
- Modulus of elasticity final (MPa) ≈ 66600
- Coefficient of linear expansion, β , (1/°C) $\approx 21.12 * 10^{-6}$

A/B SCHEDULES PHASE CONDUCTOR SPECIFICATION SHEETS

Schedule A: Purchaser's specific requirements

Schedule B: Particulars of equipment to be supplied

Conductor Type

Description	Schedule A	Schedule B
IEC Code	403.77-A1/S1A-45/3.38-7/2.25	
Conductor Overall Diameter (mm)	27.00	
Area Aluminium (mm ²)	403.77	
Area Total (mm ²)	431.60	
Aluminium wires (number off) / (diameter mm)	45/3.38	
Steel wires (number off) / (diameter mm)	7/2.25	
Conductor linear mass (kg/km)- ungreased value	1340	
Ultimate Tensile Strength (kN)	98.70	
Resistance DC @ 20°C (Ohms/km)	0,0718	
Modulus Elasticity Final (MPa)	66600	
Coefficient of Linear Expansion, β , (1/°C)	$21.12 * 10^{-6}$	
Drum Length (m)	3000	
Matched Sets	Yes	
Greased (As specified in 13TB-015. Equivalent products subject to Eskom's approval.).	Greased and ungreased.	

Zebra ACSR conductor

ALTERNATIVE phase conductor

If an alternative conductor is offered, the following electrical and mechanical properties shall be observed:

- Resistance (Ohms/km) ≤ 0.0674
- Conductor diameter (mm) ≈ 28.62
- Ultimate Tensile Strength (kN) ≥ 133
- Conductor linear mass (kg/km)- ungreased value ≈ 1630
- Modulus of elasticity final (MPa) ≈ 73200
- Coefficient of linear expansion, β , (1/°C) $\approx 19.91 \times 10^{-6}$

A/B SCHEDULES phase conductor Specification Sheets

Schedule A: Purchaser's specific requirements

Schedule B: Particulars of equipment to be supplied

Conductor Type

Description	Schedule A	Schedule B
IEC Code	IEC Code 428.88-A1/S1A-54/7/3.18	
Conductor Overall Diameter (mm)	28.62	
Area Aluminium (mm ²)	428.88	
Area Total (mm ²)	484.48	
Aluminium wires (number off) / (diameter mm)	54/3.18	
Steel wires (number off) / (diameter mm)	7/3.18	
Conductor linear mass (kg/km)- ungreased value	1630	
Ultimate Tensile Strength (kN)	133	
Resistance DC @ 20°C (Ohms/km)	0.0674	
Modulus Elasticity Final (MPa)	73200	
Coefficient of Linear Expansion, β , (1/°C)	19.91* 10-6	
Drum Length (m)	3000	
Matched Sets	Yes	
Greased (As specified in 13TB-015. Equivalent products subject to Eskom's approval.).	Greased and ungreased	

IEC 450 ACSR conductor

ALTERNATIVE PHASE CONDUCTOR

If an alternative conductor is offered, the following electrical and mechanical properties shall be observed:

- Resistance (Ohms/km) ≤ 0.0642
- Conductor diameter (mm) ≈ 28.5
- Ultimate Tensile Strength (kN) ≥ 107.47
- Conductor linear mass (kg/km)- ungreased value ≈ 1485.2

A/B SCHEDULES PHASE CONDUCTOR SPECIFICATION SHEETS

Schedule A: Purchaser's specific requirements

Schedule B: Particulars of equipment to be supplied

Conductor Type

Description	Schedule A	Schedule B
IEC Code	450-A1/S1A-45/3.57-7/2.38	
Conductor Overall Diameter (mm)	28.5	
Area Aluminium (mm ²)	450	
Area Total (mm ²)	481	
Aluminium wires (number off) / (diameter mm)	45/3.57	
Steel wires (number off) / (diameter mm)	7/2.38	
Conductor linear mass (kg/km)- ungreased value	1485.2	
Ultimate Tensile Strength (kN)	107.47	
Resistance DC @ 20°C (Ohms/km)	0.0642	
Modulus Elasticity Final (MPa)	Supplier to specify	
Coefficient of Linear Expansion, β , (1/°C)	Supplier to specify	
Drum Length (m)	3000	
Matched Sets	Yes	
Greased (As specified in 13TB-015. Equivalent products subject to Eskom's approval.)	Greased and ungreased.	

Rail ACSR conductor

ALTERNATIVE phase conductor

If an alternative conductor is offered, the following electrical and mechanical properties shall be observed:

- Resistance (Ohms/km) ≤ 0.0598
- Conductor diameter (mm) ≈ 29.59
- Ultimate Tensile Strength (kN) ≥ 117
- Conductor linear mass (kg/km)- ungreased value ≈ 1610
- Modulus of elasticity final (MPa) ≈ 66700
- Coefficient of linear expansion, β , (1/°C) $\approx 21.11 * 10^{-6}$

A/B SCHEDULES phase conductor Specification Sheets

Schedule A: Purchaser's specific requirements

Schedule B: Particulars of equipment to be supplied

Conductor Type

Description	Schedule A	Schedule B
IEC Code	483.84-A1/S1A-45/3.70-7/2.47	
Conductor Overall Diameter (mm)	29.59	
Area Aluminium (mm ²)	483.84	
Area Total (mm ²)	517.39	
Aluminium wires (number off) / (diameter mm)	45/3.70	
Steel wires (number off) / (diameter mm)	7/2.47	
Conductor linear mass (kg/km)- ungreased value	1610	
Ultimate Tensile Strength (kN)	117	
Resistance DC @ 20°C (Ohms/km)	0.0598	
Modulus Elasticity Final (MPa)	66700	
Coefficient of Linear Expansion, β , (1/°C)	21.11 * 10 ⁻⁶	
Drum Length (m)	3000	
Matched Sets	Yes	
Greased (As specified in 13TB-015. Equivalent products subject to Eskom's approval.).	Greased and ungreased.	

IEC 500 ACSR conductor

ALTERNATIVE PHASE CONDUCTOR

If an alternative conductor is offered, the following electrical and mechanical properties shall be observed:

- Resistance (Ohms/km) ≤ 0.0578
- Conductor diameter (mm) ≈ 30.1
- Ultimate Tensile Strength (kN) ≥ 119.41
- Conductor linear mass (kg/km)- ungreased value ≈ 1650.2

A/B SCHEDULES PHASE CONDUCTOR SPECIFICATION SHEETS

Schedule A: Purchaser's specific requirements

Schedule B: Particulars of equipment to be supplied

Conductor Type

Description	Schedule A	Schedule B
IEC Code	500-A1/S1A-45/3.76-7/2.51	
Conductor Overall Diameter (mm)	30.1	
Area Aluminium (mm ²)	500	
Area Total (mm ²)	535	
Aluminium wires (number off) / (diameter mm)	45/3.76	
Steel wires (number off) / (diameter mm)	7/2.51	
Conductor linear mass (kg/km)- ungreased value	1650.2	
Ultimate Tensile Strength (kN)	119.41	
Resistance DC @ 20°C (Ohms/km)	0.0578	
Modulus Elasticity Final (MPa)	Supplier to specify	
Coefficient of Linear Expansion, β , (1/°C)	Supplier to specify	
Drum Length (m)	3000	
Matched Sets	Yes	
Greased (As specified in 13TB-015. Equivalent products subject to Eskom's approval.)	Greased and ungreased.	

IEC 560 ACSR conductor

ALTERNATIVE PHASE CONDUCTOR

If an alternative conductor is offered, the following electrical and mechanical properties shall be observed:

- Resistance (Ohms/km) ≤ 0.0516
- Conductor diameter (mm) ≈ 31.8
- Ultimate Tensile Strength (kN) ≥ 133.74
- Conductor linear mass (kg/km)- ungreased value ≈ 1848.2

A/B SCHEDULES PHASE CONDUCTOR SPECIFICATION SHEETS

Schedule A: Purchaser's specific requirements

Schedule B: Particulars of equipment to be supplied

Conductor Type

Description	Schedule A	Schedule B
IEC Code	560-A1/S1A-45/3.98-7/2.65	
Conductor Overall Diameter (mm)	31.8	
Area Aluminium (mm ²)	560	
Area Total (mm ²)	599	
Aluminium wires (number off) / (diameter mm)	45/3.98	
Steel wires (number off) / (diameter mm)	7/2.65	
Conductor linear mass (kg/km)- ungreased value	1848.2	
Ultimate Tensile Strength (kN)	133.74	
Resistance DC @ 20°C (Ohms/km)	0.0516	
Modulus Elasticity Final (MPa)	Supplier to specify	
Coefficient of Linear Expansion, β , (1/°C)	Supplier to specify	
Drum Length (m)	3000	
Matched Sets	Yes	
Greased (As specified in 13TB-015. Equivalent products subject to Eskom's approval.)	Greased and ungreased.	

IEC 630 ACSR conductor

ALTERNATIVE PHASE CONDUCTOR

If an alternative conductor is offered, the following electrical and mechanical properties shall be observed:

- Resistance (Ohms/km) ≤ 0.0459
- Conductor diameter (mm) ≈ 33.8
- Ultimate Tensile Strength (kN) ≥ 150.45
- Conductor linear mass (kg/km)- ungreased value ≈ 2079.2

A/B SCHEDULES PHASE CONDUCTOR SPECIFICATION SHEETS

Schedule A: Purchaser's specific requirements

Schedule B: Particulars of equipment to be supplied

Conductor Type

Description	Schedule A	Schedule B
IEC Code	630-A1/S1A-45/4.22-7/2.81	
Conductor Overall Diameter (mm)	33.8	
Area Aluminium (mm ²)	630	
Area Total (mm ²)	674	
Aluminium wires (number off) / (diameter mm)	45/4.22	
Steel wires (number off) / (diameter mm)	7/2.81	
Conductor linear mass (kg/km)- ungreased value	2079.2	
Ultimate Tensile Strength (kN)	150.45	
Resistance DC @ 20°C (Ohms/km)	0.0459	
Modulus Elasticity Final (MPa)	Supplier to specify	
Coefficient of Linear Expansion, β , (1/°C)	Supplier to specify	
Drum Length (m)	3000	
Matched Sets	Yes	
Greased (As specified in 13TB-015. Equivalent products subject to Eskom's approval.)	Greased and ungreased.	

Dinosaur ACSR conductor

ALTERNATIVE phase conductor

If an alternative conductor is offered, the following electrical and mechanical properties shall be observed:

- Resistance (Ohms/km) ≤ 0.0437
- Conductor diameter (mm) ≈ 35.55
- Ultimate Tensile Strength (kN) ≥ 202.92
- Conductor linear mass (kg/km)- ungreased value ≈ 2493
- Modulus of elasticity final (MPa) ≈ 72200
- Coefficient of linear expansion, β , (1/°C) $\approx 19.91 \times 10^{-6}$

A/B SCHEDULES phase conductor Specification Sheets

Schedule A: Purchaser's specific requirements

Schedule B: Particulars of equipment to be supplied

Conductor Type

Description	Schedule A	Schedule B
IEC Code	661.72-A1/S1A-54/3.95-19/2.36	
Conductor Overall Diameter (mm)	35.55	
Area Aluminium (mm ²)	661.72	
Area Total (mm ²)	744.84	
Aluminium wires (number off) / (diameter mm)	54/3.95	
Steel wires (number off) / (diameter mm)	19/2.36	
Conductor linear mass (kg/km)- ungreased value	2493	
Ultimate Tensile Strength (kN)	202.92	
Resistance DC @ 20°C (Ohms/km)	0.0437	
Modulus Elasticity Final (MPa)	72200	
Coefficient of Linear Expansion, β , (1/°C)	19.91* 10-6	
Drum Length (m)	2000	
Matched Sets	Yes	
Greased (As specified in 13TB-015. Equivalent products subject to Eskom's approval.).	Greased and Ungreased.	

Bersfort ACSR conductor

ALTERNATIVE PHASE CONDUCTOR

If an alternative conductor is offered, the following electrical and mechanical properties shall be observed:

- Resistance (Ohms/km) $\leq 0,0420$
- Conductor diameter (mm) ≈ 35.58
- Ultimate Tensile Strength (kN) ≥ 177.65
- Conductor linear mass (kg/km)- ungreased value ≈ 2386
- Modulus of elasticity final (MPa) ≈ 68800
- Coefficient of linear expansion, β , (1/°C) $\approx 20.68 * 10^{-6}$

A/B SCHEDULES PHASE CONDUCTOR SPECIFICATION SHEETS

Schedule A: Purchaser's specific requirements

Schedule B: Particulars of equipment to be supplied

Conductor Type

Description	Schedule A	Schedule B
IEC Code	687.36-A1/S1A-48/4.27-7/3.32	
Conductor Overall Diameter (mm)	35.58	
Area Aluminium (mm ²)	687.36	
Area Total (mm ²)	747.96	
Aluminium wires (number off) / (diameter mm)	48/4.27	
Steel wires (number off) / (diameter mm)	7/3.32	
Conductor linear mass (kg/km)- ungreased value	2386	
Ultimate Tensile Strength (kN)	177.65	
Resistance DC @ 20°C (Ohms/km)	0,0420	
Modulus Elasticity Final (MPa)	68800	
Coefficient of Linear Expansion, β , (1/°C)	$20.68 * 10^{-6}$	
Drum Length (m)	2000	
Matched Sets	Yes	
Greased (As specified in 13TB-015. Equivalent products subject to Eskom's approval.).	Greased and ungreased.	

IEC 800 ACSR conductor

ALTERNATIVE PHASE CONDUCTOR

If an alternative conductor is offered, the following electrical and mechanical properties shall be observed:

- Resistance (Ohms/km) ≤ 0.0361
- Conductor diameter (mm) ≈ 37.6
- Ultimate Tensile Strength (kN) ≥ 167.41
- Conductor linear mass (kg/km)- ungreased value ≈ 2480.2

A/B SCHEDULES PHASE CONDUCTOR SPECIFICATION SHEETS

Schedule A: Purchaser's specific requirements

Schedule B: Particulars of equipment to be supplied

Conductor Type

Description	Schedule A	Schedule B
IEC Code	800-A1/S1A-72/3,76 - 7/2,51	
Conductor Overall Diameter (mm)	37.6	
Area Aluminium (mm ²)	800	
Area Total (mm ²)	835	
Aluminium wires (number off) / (diameter mm)	72/3.76	
Steel wires (number off) / (diameter mm)	7/2.51	
Conductor linear mass (kg/km)- ungreased value	2480.2	
Ultimate Tensile Strength (kN)	167.41	
Resistance DC @ 20°C (Ohms/km)	0.0361	
Modulus Elasticity Final (MPa)	Supplier to specify	
Coefficient of Linear Expansion, β , (1/°C)	Supplier to specify	
Drum Length (m)	2000	
Matched Sets	Yes	
Greased (As specified in 13TB-015. Equivalent products subject to Eskom's approval.).	Greased and ungreased.	

Acacia (Grs) AAAC conductor

ALTERNATIVE phase conductor

If an alternative conductor is offered, the following electrical and mechanical properties shall be observed:

- Resistance (Ohms/km) ≤ 1.39
- Conductor diameter (mm) ≈ 6.24
- Ultimate Tensile Strength (kN) ≥ 6.69
- Conductor linear mass (kg/km)- ungreased value ≈ 65
- Modulus of elasticity final (MPa) ≈ 61000
- Coefficient of linear expansion, β , (1/°C) $\approx 23 \times 10^{-6}$

A/B SCHEDULES phase conductor Specification Sheets

Schedule A: Purchaser's specific requirements

Schedule B: Particulars of equipment to be supplied

Conductor Type

Description	Schedule A	Schedule B
IEC Code	IEC Code 23.79-A2-7/2.08	
Conductor Overall Diameter (mm)	6.24	
Area Aluminium (mm ²)	23.79	
Area Total (mm ²)	23.79	
Aluminium wires (number off) / (diameter mm)	7/2.08	
Steel wires (number off) / (diameter mm)	N/A	
Conductor linear mass (kg/km)- ungreased value	65	
Ultimate Tensile Strength (kN)	6.69	
Resistance DC @ 20°C (Ohms/km)	1.39	
Modulus Elasticity Final (MPa)	61000	
Coefficient of Linear Expansion, β , (1/°C)	23×10^{-6}	
Drum Length (m)	3000	
Matched Sets	No	
Greased (As specified in 13TB-015. Equivalent products subject to Eskom's approval.).	Greased and ungreased	

Code 35 (Grs) AAAC conductor

ALTERNATIVE phase conductor

If an alternative conductor is offered, the following electrical and mechanical properties shall be observed:

- Resistance (Ohms/km) ≤ 0.785
- Conductor diameter (mm) ≈ 8.31
- Ultimate Tensile Strength (kN) ≥ 11.86
- Conductor linear mass (kg/km)- ungreased value ≈ 115
- Modulus of elasticity final (MPa) ≈ 61000
- Coefficient of linear expansion, β , (1/°C) $\approx 23 \times 10^{-6}$

A/B SCHEDULES phase conductor Specification Sheets

Schedule A: Purchaser's specific requirements

Schedule B: Particulars of equipment to be supplied

Conductor Type

Description	Schedule A	Schedule B
IEC Code	IEC Code 42.18-A2-7/2.77	
Conductor Overall Diameter (mm)	8.31	
Area Aluminium (mm ²)	42.18	
Area Total (mm ²)	42.18	
Aluminium wires (number off) / (diameter mm)	7/2.77	
Steel wires (number off) / (diameter mm)	N/A	
Conductor linear mass (kg/km)- ungreased value	115	
Ultimate Tensile Strength (kN)	11.86	
Resistance DC @ 20°C (Ohms/km)	0.785	
Modulus Elasticity Final (MPa)	61000	
Coefficient of Linear Expansion, β , (1/°C)	23×10^{-6}	
Drum Length (m)	1500	
Matched Sets	No	
Greased (As specified in 13TB-015. Equivalent products subject to Eskom's approval.).	Greased and ungreased	

Pine AAAC conductor

ALTERNATIVE PHASE CONDUCTOR

If an alternative conductor is offered, the following electrical and mechanical properties shall be observed:

- Resistance (Ohms/km) ≤ 0.462
- Conductor diameter (mm) ≈ 10.83
- Ultimate Tensile Strength (kN) ≥ 20.2
- Conductor linear mass (kg/km)- ungreased value ≈ 196
- Modulus of elasticity final (MPa) ≈ 61000
- Coefficient of linear expansion, β , (1/°C) $\approx 23 * 10^{-6}$

A/B SCHEDULES PHASE CONDUCTOR SPECIFICATION SHEETS

Schedule A: Purchaser's specific requirements

Schedule B: Particulars of equipment to be supplied

Conductor Type

Description	Schedule A	Schedule B
IEC Code	71.65-A2-7/3.61	
Conductor Overall Diameter (mm)	10.83	
Area Aluminium (mm ²)	71.65	
Area Total (mm ²)	71.65	
Aluminium wires (number off) / (diameter mm)	7/3.61	
Conductor linear mass (kg/km)- ungreased value	196	
Ultimate Tensile Strength (kN)	20.2	
Resistance DC @ 20°C (Ohms/km)	0.462	
Modulus Elasticity Final (MPa)	61000	
Coefficient of Linear Expansion, β , (1/°C)	23 * 10-6	
Drum Length (m)	3000	
Matched Sets	Yes	
Greased (As specified in 13TB-015. Equivalent products subject to Eskom's approval.).	Greased and ungreased.	

Oak AAAC conductor

ALTERNATIVE PHASE CONDUCTOR

If an alternative conductor is offered, the following electrical and mechanical properties shall be observed:

- Resistance (Ohms/km) ≤ 0.279
- Conductor diameter (mm) ≈ 13.95
- Ultimate Tensile Strength (kN) ≥ 33.33
- Conductor linear mass (kg/km)- ungreased value ≈ 325
- Modulus of elasticity final (MPa) ≈ 61000
- Coefficient of linear expansion, β , (1/°C) $\approx 23 * 10^{-6}$

A/B SCHEDULES PHASE CONDUCTOR SPECIFICATION SHEETS

Schedule A: Purchaser's specific requirements

Schedule B: Particulars of equipment to be supplied

Conductor Type

Description	Schedule A	Schedule B
IEC Code	118.9-A2-7/4.65	
Conductor Overall Diameter (mm)	13.95	
Area Aluminium (mm ²)	118.9	
Area Total (mm ²)	118.9	
Aluminium wires (number off) / (diameter mm)	7/4.65	
Conductor linear mass (kg/km)- ungreased value	325	
Ultimate Tensile Strength (kN)	33.33	
Resistance DC @ 20°C (Ohms/km)	0.279	
Modulus Elasticity Final (MPa)	61000	
Coefficient of Linear Expansion, β , (1/°C)	23 * 10-6	
Drum Length (m)	1500	
Matched Sets	YES	
Greased (As specified in 13TB-015. Equivalent products subject to Eskom's approval.).	Greased and ungreased.	

IEC 160 AAAC conductor

ALTERNATIVE PHASE CONDUCTOR

If an alternative conductor is offered, the following electrical and mechanical properties shall be observed:

- Resistance (Ohms/km) ≤ 0.1798
- Conductor diameter (mm) ≈ 17.6
- Ultimate Tensile Strength (kN) ≥ 54.32
- Conductor linear mass (kg/km)- ungreased value ≈ 506.1

A/B SCHEDULES PHASE CONDUCTOR SPECIFICATION SHEETS

Schedule A: Purchaser's specific requirements

Schedule B: Particulars of equipment to be supplied

Conductor Type

Description	Schedule A	Schedule B
IEC Code	184-A2-19/3.51	
Conductor Overall Diameter (mm)	17.6	
Area Aluminium (mm ²)	184	
Area Total (mm ²)	184	
Aluminium wires (number off) / (diameter mm)	19/3.51	
Conductor linear mass (kg/km)- ungreased value	506.1	
Ultimate Tensile Strength (kN)	54.32	
Resistance DC @ 20°C (Ohms/km)	0.1798	
Modulus Elasticity Final (MPa)	Supplier to specify	
Coefficient of Linear Expansion, β , (1/°C)	Supplier to specify	
Drum Length (m)	3000	
Matched Sets	Yes	
Greased (As specified in 13TB-015. Equivalent products subject to Eskom's approval.).	Greased and ungreased.	

IEC 315 AAAC conductor

ALTERNATIVE PHASE CONDUCTOR

If an alternative conductor is offered, the following electrical and mechanical properties shall be observed:

- Resistance (Ohms/km) ≤ 0.0916
- Conductor diameter (mm) ≈ 24.7
- Ultimate Tensile Strength (kN) ≥ 106.95
- Conductor linear mass (kg/km)- ungreased value ≈ 998.9

A/B SCHEDULES PHASE CONDUCTOR SPECIFICATION SHEETS

Schedule A: Purchaser's specific requirements

Schedule B: Particulars of equipment to be supplied

Conductor Type

Description	Schedule A	Schedule B
IEC Code	363-A2-37/3.53	
Conductor Overall Diameter (mm)	24.7	
Area Aluminium (mm ²)	363	
Area Total (mm ²)	363	
Aluminium wires (number off) / (diameter mm)	37/3.53	
Conductor linear mass (kg/km)- ungreased value	998.9	
Ultimate Tensile Strength (kN)	106.95	
Resistance DC @ 20°C (Ohms/km)	0.0916	
Modulus Elasticity Final (MPa)	Supplier to specify	
Coefficient of Linear Expansion, β , (1/°C)	Supplier to specify	
Drum Length (m)	3000	
Matched Sets	Yes	
Greased (As specified in 13TB-015. Equivalent products subject to Eskom's approval.).	Greased and ungreased.	

IEC 400 AAAC conductor

ALTERNATIVE PHASE CONDUCTOR

If an alternative conductor is offered, the following electrical and mechanical properties shall be observed:

- Resistance (Ohms/km) ≤ 0.0721
- Conductor diameter (mm) ≈ 27.9
- Ultimate Tensile Strength (kN) ≥ 135.81
- Conductor linear mass (kg/km)- ungreased value ≈ 1268.4

A/B SCHEDULES PHASE CONDUCTOR SPECIFICATION SHEETS

Schedule A: Purchaser's specific requirements

Schedule B: Particulars of equipment to be supplied

Conductor Type

Description	Schedule A	Schedule B
IEC Code	460-A2-37/3.98	
Conductor Overall Diameter (mm)	27.9	
Area Aluminium (mm ²)	460	
Area Total (mm ²)	460	
Aluminium wires (number off) / (diameter mm)	37/3.98	
Conductor linear mass (kg/km)- ungreased value	1268.4	
Ultimate Tensile Strength (kN)	135.81	
Resistance DC @ 20°C (Ohms/km)	0.0721	
Modulus Elasticity Final (MPa)	Supplier to specify	
Coefficient of Linear Expansion, β , (1/°C)	Supplier to specify	
Drum Length (m)	3000	
Matched Sets	Yes	
Greased (As specified in 13TB-015. Equivalent products subject to Eskom's approval.).	Greased and ungreased.	

IEC 450 AAAC conductor

ALTERNATIVE PHASE CONDUCTOR

If an alternative conductor is offered, the following electrical and mechanical properties shall be observed:

- Resistance (Ohms/km) ≤ 0.0641
- Conductor diameter (mm) ≈ 29.6
- Ultimate Tensile Strength (kN) ≥ 152.79
- Conductor linear mass (kg/km)- ungreased value ≈ 1426.9

A/B SCHEDULES PHASE CONDUCTOR SPECIFICATION SHEETS

Schedule A: Purchaser's specific requirements

Schedule B: Particulars of equipment to be supplied

Conductor Type

Description	Schedule A	Schedule B
IEC Code	518-A2-37/4.22	
Conductor Overall Diameter (mm)	29.6	
Area Aluminium (mm ²)	518	
Area Total (mm ²)	518	
Aluminium wires (number off) / (diameter mm)	37/4.22	
Conductor linear mass (kg/km)- ungreased value	1426.9	
Ultimate Tensile Strength (kN)	152.79	
Resistance DC @ 20°C (Ohms/km)	0.0641	
Modulus Elasticity Final (MPa)	Supplier to specify	
Coefficient of Linear Expansion, β , (1/°C)	Supplier to specify	
Drum Length (m)	3000	
Matched Sets	Yes	
Greased (As specified in 13TB-015. Equivalent products subject to Eskom's approval.).	Greased and ungreased.	

IEC 500 AAAC conductor

ALTERNATIVE PHASE CONDUCTOR

If an alternative conductor is offered, the following electrical and mechanical properties shall be observed:

- Resistance (Ohms/km) ≤ 0.0577
- Conductor diameter (mm) ≈ 31.2
- Ultimate Tensile Strength (kN) ≥ 169.76
- Conductor linear mass (kg/km)- ungreased value ≈ 1585.5

A/B SCHEDULES PHASE CONDUCTOR SPECIFICATION SHEETS

Schedule A: Purchaser's specific requirements

Schedule B: Particulars of equipment to be supplied

Conductor Type

Description	Schedule A	Schedule B
IEC Code	575-A2-37/4.45	
Conductor Overall Diameter (mm)	31.2	
Area Aluminium (mm ²)	575	
Area Total (mm ²)	575	
Aluminium wires (number off) / (diameter mm)	37/4.45	
Conductor linear mass (kg/km)- ungreased value	1585.5	
Ultimate Tensile Strength (kN)	169.76	
Resistance DC @ 20°C (Ohms/km)	0.0577	
Modulus Elasticity Final (MPa)	Supplier to specify	
Coefficient of Linear Expansion, β , (1/°C)	Supplier to specify	
Drum Length (m)	3000	
Matched Sets	Yes	
Greased (As specified in 13TB-015. Equivalent products subject to Eskom's approval.).	Greased and ungreased.	

IEC 560 AAAC conductor

ALTERNATIVE PHASE CONDUCTOR

If an alternative conductor is offered, the following electrical and mechanical properties shall be observed:

- Resistance (Ohms/km) ≤ 0.0516
- Conductor diameter (mm) $\approx 33,0$
- Ultimate Tensile Strength (kN) ≥ 190.14
- Conductor linear mass (kg/km)- ungreased value ≈ 1778.4

A/B SCHEDULES PHASE CONDUCTOR SPECIFICATION SHEETS

Schedule A: Purchaser's specific requirements

Schedule B: Particulars of equipment to be supplied

Conductor Type

Description	Schedule A	Schedule B
IEC Code	645-A2-61/3.67	
Conductor Overall Diameter (mm)	33.0	
Area Aluminium (mm ²)	645	
Area Total (mm ²)	645	
Aluminium wires (number off) / (diameter mm)	61/3.67	
Conductor linear mass (kg/km)- ungreased value	1778.4	
Ultimate Tensile Strength (kN)	190.14	
Resistance DC @ 20°C (Ohms/km)	0.0516	
Modulus Elasticity Final (MPa)	Supplier to specify	
Coefficient of Linear Expansion, β , (1/°C)	Supplier to specify	
Drum Length (m)	2000	
Matched Sets	Yes	
Greased (As specified in 13TB-015. Equivalent products subject to Eskom's approval.).	Greased and ungreased.	

IEC 630 AAAC conductor

ALTERNATIVE PHASE CONDUCTOR

If an alternative conductor is offered, the following electrical and mechanical properties shall be observed:

- Resistance (Ohms/km) ≤ 0.0458
- Conductor diameter (mm) ≈ 35.0
- Ultimate Tensile Strength (kN) ≥ 213.9
- Conductor linear mass (kg/km)- ungreased value ≈ 2000.7

A/B SCHEDULES PHASE CONDUCTOR SPECIFICATION SHEETS

Schedule A: Purchaser's specific requirements

Schedule B: Particulars of equipment to be supplied

Conductor Type

DESCRIPTION	SCHEDULE A	SCHEDULE B
IEC Code	725-A2-61/3.89	
Conductor Overall Diameter (mm)	35.0	
Area Aluminium (mm ²)	725	
Area Total (mm ²)	725	
Aluminium wires (number off) / (diameter mm)	61/3.89	
Conductor linear mass (kg/km)- ungreased value	2000.7	
Ultimate Tensile Strength (kN)	213.9	
Resistance DC @ 20°C (Ohms/km)	0.0458	
Modulus Elasticity Final (MPa)	Supplier to specify	
Coefficient of Linear Expansion, β , (1/°C)	Supplier to specify	
Drum Length (m)	2000	
Matched Sets	Yes	
Greased (As specified in 13TB-015. Equivalent products subject to Eskom's approval.).	Greased and ungreased.	

IEC 710 AAAC conductor

ALTERNATIVE PHASE CONDUCTOR

If an alternative conductor is offered, the following electrical and mechanical properties shall be observed:

- Resistance (Ohms/km) ≤ 0.0407
- Conductor diameter (mm) ≈ 37.2
- Ultimate Tensile Strength (kN) ≥ 241.07
- Conductor linear mass (kg/km)- ungreased value ≈ 2254.8

A/B SCHEDULES PHASE CONDUCTOR SPECIFICATION SHEETS

Schedule A: Purchaser's specific requirements

Schedule B: Particulars of equipment to be supplied

Conductor Type

Description	Schedule A	Schedule B
IEC Code	817-A2-61/4.13	
Conductor Overall Diameter (mm)	37.2	
Area Aluminium (mm ²)	817	
Area Total (mm ²)	817	
Aluminium wires (number off) / (diameter mm)	61/4.13	
Conductor linear mass (kg/km)- ungreased value	2254.8	
Ultimate Tensile Strength (kN)	241.07	
Resistance DC @ 20°C (Ohms/km)	0.0407	
Modulus Elasticity Final (MPa)	Supplier to specify	
Coefficient of Linear Expansion, β , (1/°C)	Supplier to specify	
Drum Length (m)	2000	
Matched Sets	Yes	
Greased (As specified in 13TB-015. Equivalent products subject to Eskom's approval.).	Greased and ungreased.	

IEC 800 AAAC conductor

ALTERNATIVE PHASE CONDUCTOR

If an alternative conductor is offered, the following electrical and mechanical properties shall be observed:

- Resistance (Ohms/km) ≤ 0.0361
- Conductor diameter (mm) ≈ 39.5
- Ultimate Tensile Strength (kN) ≥ 271.62
- Conductor linear mass (kg/km)- ungreased value ≈ 2540.6

A/B SCHEDULES PHASE CONDUCTOR SPECIFICATION SHEETS

Schedule A: Purchaser's specific requirements

Schedule B: Particulars of equipment to be supplied

Conductor Type

DESCRIPTION	SCHEDULE A	SCHEDULE B
IEC Code	921-A2-61/4.38	
Conductor Overall Diameter (mm)	39.5	
Area Aluminium (mm ²)	921	
Area Total (mm ²)	921	
Aluminium wires (number off) / (diameter mm)	61/4.38	
Conductor linear mass (kg/km)- ungreased value	2540.6	
Ultimate Tensile Strength (kN)	271.62	
Resistance DC @ 20°C (Ohms/km)	0.0361	
Modulus Elasticity Final (MPa)	Supplier to specify	
Coefficient of Linear Expansion, β , (1/°C)	Supplier to specify	
Drum Length (m)	1500	
Matched Sets	Yes	
Greased (As specified in 13TB-015. Equivalent products subject to Eskom's approval.).	Greased and ungreased.	

Hornet AAC conductor (Insulated and non-insulated)

ALTERNATIVE phase conductor

If an alternative conductor is offered, the following electrical and mechanical properties shall be observed:

- Resistance (Ohms/km) ≤ 0.1825
- Conductor diameter (mm) ≈ 16.25
- Ultimate Tensile Strength (kN) ≥ 26
- Conductor linear mass (kg/km)- ungreased value ≈ 435
- Modulus of elasticity final (MPa) ≈ 59650
- Coefficient of linear expansion, β , (1/°C) $\approx 23 \times 10^{-6}$

A/B SCHEDULES phase conductor Specification Sheets

Schedule A: Purchaser's specific requirements

Schedule B: Particulars of equipment to be supplied

Conductor Type

Description	Schedule A	Schedule B
IEC Code	157.62-A1-19/3.25	
Conductor Overall Diameter (mm)	16.25	
Area Aluminium (mm ²)	157.62	
Area Total (mm ²)	157.62	
Aluminium wires (number off) / (diameter mm)	19/3.25	
Steel wires (number off) / (diameter mm)	N/A	
Conductor linear mass (kg/km)- ungreased value	435	
Ultimate Tensile Strength (kN)	26	
Resistance DC @ 20°C (Ohms/km)	0.1825	
Modulus Elasticity Final (MPa)	59650	
Coefficient of Linear Expansion, β , (1/°C)	23×10^{-6}	
Drum Length (m)	1500	
Matched Sets	No	
Greased (As specified in 13TB-015. Equivalent products subject to Eskom's approval.).	Greased and ungreased	
Insulated (Specification) material, thickness	Insulated and non-insulated	

Centipede AAC conductor (Insulated and non-insulated)

ALTERNATIVE phase conductor

If an alternative conductor is offered, the following electrical and mechanical properties shall be observed:

- Resistance (Ohms/km) ≤ 0.0694
- Conductor diameter (mm) ≈ 26.46
- Ultimate Tensile Strength (kN) ≥ 67.2
- Conductor linear mass (kg/km)- ungreased value ≈ 1150
- Modulus of elasticity final (MPa) ≈ 58600
- Coefficient of linear expansion, β , (1/°C) $\approx 23 \times 10^{-6}$

A/B SCHEDULES phase conductor Specification Sheets

Schedule A: Purchaser's specific requirements

Schedule B: Particulars of equipment to be supplied

Conductor Type

Description	Schedule A	Schedule B
IEC Code	415.22-A1-37/3.78	
Conductor Overall Diameter (mm)	26.46	
Area Aluminium (mm ²)	415.22	
Area Total (mm ²)	415.22	
Aluminium wires (number off) / (diameter mm)	37/3.78	
Steel wires (number off) / (diameter mm)	N/A	
Conductor linear mass (kg/km)- ungreased value	1150	
Ultimate Tensile Strength (kN)	67.2	
Resistance DC @ 20°C (Ohms/km)	0.0694	
Modulus Elasticity Final (MPa)	58600	
Coefficient of Linear Expansion, β , (1/°C)	23×10^{-6}	
Drum Length (m)	1000	
Matched Sets	No	
Greased (As specified in 13TB-015. Equivalent products subject to Eskom's approval.).	Greased and ungreased	
Insulated (Specification) material, thickness	Insulated and non-insulated	

Bull AAC conductor (Insulated and Non-insulated)

ALTERNATIVE phase conductor

If an alternative conductor is offered, the following electrical and mechanical properties shall be observed:

- Resistance (Ohms/km) ≤ 0.0334
- Conductor diameter (mm) ≈ 38.25
- Ultimate Tensile Strength (kN) ≥ 139
- Conductor linear mass (kg/km)- ungreased value ≈ 2400
- Modulus of elasticity final (MPa) ≈ 57570
- Coefficient of linear expansion, β , (1/°C) $\approx 23 \times 10^{-6}$

A/B SCHEDULES phase conductor Specification Sheets

Schedule A: Purchaser's specific requirements

Schedule B: Particulars of equipment to be supplied

Conductor Type

Description	Schedule A	Schedule B
IEC Code	865.36-A1-61/4.25	
Conductor Overall Diameter (mm)	38.25	
Area Aluminium (mm ²)	865.36	
Area Total (mm ²)	865.36	
Aluminium wires (number off) / (diameter mm)	61/4.25	
Steel wires (number off) / (diameter mm)	N/A	
Conductor linear mass (kg/km)- ungreased value	2400	
Ultimate Tensile Strength (kN)	139	
Resistance DC @ 20°C (Ohms/km)	0.0334	
Modulus Elasticity Final (MPa)	57570	
Coefficient of Linear Expansion, β , (1/°C)	23×10^{-6}	
Drum Length (m)	1000	
Matched Sets	No	
Greased (As specified in 13TB-015. Equivalent products subject to Eskom's approval.).	Greased and ungreased	
Insulated (Specification) material, thickness	Insulated and non-insulated	

Annex B – Conductor Strand Marking

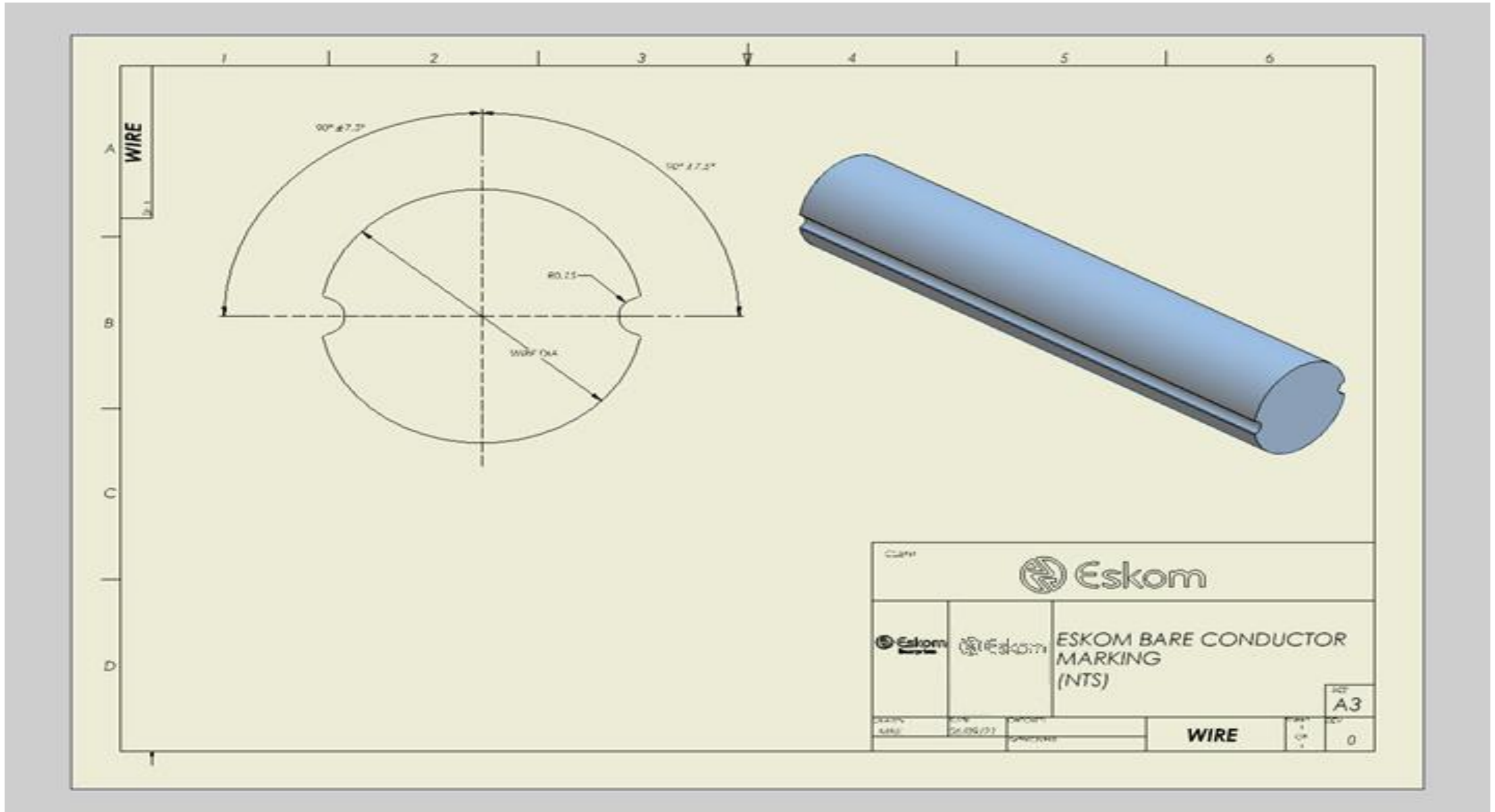

ESKOM COPYRIGHT PROTECTED

When downloaded from the WEB, this document is uncontrolled and the responsibility rests with the user to ensure it is in line with the authorized version on the WEB.

Annex C – Conductor properties, ampacity and drum properties

Type	Name	IEC code	Diameter (mm)	UTS (kN)	Mass (kg/km) – ungreased value	DC resistance @ 20°C Ω/km	Current rating (RA – Rate A, RB – Rate B) (Rate A is an indication of conductor normal ampacity rating, Rate B is an indication of conductor emergency ampacity rating)								Length (m)	Drum size				
							50°C		60°C		70°C		80°C			Flange diameter (mm)	Barrel diameter (mm)	Width (mm)	Flange thickness (mm)	Spindle hole diameter (mm)
							RA	RB	RA	RB	RA	RB	RA	RB						
ACSR	Squirrel	20.98-A1/S1A-6/1/2.11	6.33	8.02	85.2	1.3677	104	143	122	165	138	183	150	198	3000	950	500	790	140	80
	Magpie	10.58-A1/S1A-3/2.12-4/2.12	6.35	18.573	139.7	2.707	33	40	47	52	58	62	67	70	3000	950	500	790	140	80
	Fox	36.68-A1/S1A-6/1/2.79	8.37	13.1	149	0.7822	148	203	173	234	196	258	213	279	1500	850	400	630	130	80
	Mink	63.13-A1/S1A-6/1/3.66	10.98	21.9	257	0.4546	206	285	241	325	270	361	294	391	1500	950	450	790	140	80
	Horse	73.36-A1/S1A-12/7/2.79	13.95	60.7	541	0.3939	246	343	290	389	322	428	351	462	2000	1350	700	1050	150	92
	Hare	104.98-A1/S1A-6/1/4.72	14.16	36	427	0.2733	280	392	335	448	376	496	410	538	1500	1050	600	1050	150	80
	Tiger	131.23-A1/S1A-30/7/2.36	16.52	58.7	606	0.2202	322	466	393	535	444	593	485	643	2000	1350	700	1050	150	92
	Oden (AC)	117-A1/S1A-12/7/3.52	17.6	102.75	860	0.23	329	458	390	520	433	571	470	615	1500	1350	700	1050	150	92
	Oden (DC)	117-A1/S1A-12/7/3.52	17.6	102.75	860	0.23	332	474	397	543	445	601	486	650	1500	1350	700	1050	150	92
	Wolf	158.06-A1/S1A-30/7/2.59	18.13	69.2	730	0.1828	363	528	444	605	498	671	547	727	1500	1350	700	1050	150	92
	Chickadee	200.93-A1/S1A-18/1/3.77	18.87	44.9	643	0.1427	419	602	496	691	559	761	608	823	3000	1850	1000	1066	166	92
	Panther	212.06-A1/S1A-30/7/3.00	21	90.8	970	0.1363	441	642	536	737	606	818	662	883	3000	2250	1200	1102	202	92
	Bear	264.42-A1/S1A-30/7/3.35	23.45	112	1220	0.1093	521	767	625	873	706	962	773	1041	1500	1850	900	1066	166	92
Kingbird	323.01-A1/S1A-18/1/4.78	23.9	71.32	1038	0.0891	586	831	684	949	771	1045	837	1136	1500	1850	900	1066	166	92	

ESKOM COPYRIGHT PROTECTED

When downloaded from the WEB, this document is uncontrolled and the responsibility rests with the user to ensure it is in line with the authorized version on the WEB.

	IEC 315	315-A1/S1A-45/2.99-7/1.99	23.9	79.03	1039.6	0.0917	573	834	687	952	774	1050	844	1134	3000	1700	830	1110	76	89
	Goat	324.31-A1/S1A-30/7/3.71	25.97	136	1500	0.0891	618	866	726	996	813	1102	889	1197	3000	1900	960	1290	76	89
	Tern	403.77-A1/S1A-45/3.38-7/2.25	27	98.7	1340	0.0718	665	963	792	1110	894	1231	970	1324	3000	2050	1000	1302	202	92
	Zebra	428.88-A1/S1A-54/7/3.18	28.62	133	1630	0.0674	710	1022	832	1161	938	1285	1024	1391	3000	2450	1300	1252	202	92
	IEC 450	450-A1/S1A-45/3.57-7/2.38	28.5	107.47	1485.2	0.0642	726	1053	867	1207	970	1330	1057	1432	3000	2300	1270	1452	76	89
	Rail	304-A1/S1A-45/3.70-7/2.47	29.59	117	1610	0.0598	755	1109	902	1273	1101	1408	1130	1527	3000	2300	1270	1452	76	89
	IEC 500	500-A1/S1A-45/3.76-7/2.51	30.1	119.41	1650.2	0.0578	781	1133	933	1300	1043	1434	1135	1540	3000	2500	1450	1452	76	89
	IEC 560	560-A1/S1A-45/3.98-7/2.65	31.8	133.74	1848.2	0.0516	844	1230	1008	1411	1128	1556	1226	1673	3000	2650	1500	1452	76	89
	IEC 630	630-A1/S1A-45/4.22-7/2.81	33.8	150.45	2079.2	0.0459	909	1343	1087	1544	1216	1704	1325	1838	3000	2850	1600	1452	76	89
	Dinosaur	661.72-A1/S1A-54/3.95-19/2.36	35.55	202.92	2493	0.0437	938	1380	1120	1585	1267	1763	1379	1906	2000	2850	1600	1452	76	89
	Bersfort	687.36-A1/S1A-48/4.27-7/3.32	35.58	177.65	2386	0.042	965	1420	1153	1630	1304	1814	1417	1957	2000	2850	1600	1452	76	89
	IEC 800	800-A1/S1A-72/3,76 - 7/2,51	37.6	167.41	2480.2	0.0361	1089	1595	1280	1838	1435	2021	1555	2177	2000	2300	1270	1452	76	89
AAAC	Acacia (greased)	23.79-A2-7/2.08	6.24	6.69	65	1.39	108	153	129	176	145	194	157	210	3000	950	500	790	140	80
	Code 35 (greased)	42.18-A2-7/2.77	8.31	11.86	115	0.785	158	216	188	248	209	275	230	299	1500	900	400	500	50	92
	Pine	71.65-A2-7/3.61	10.83	20.2	196	0.462	219	302	261	346	293	385	320	418	3000	1150	600	950	150	80
	Oak	118.9-A2-7/4.65	13.95	33.33	325	0.279	297	417	350	479	391	530	432	575	1500	1200	600	900	50	92
	IEC 160	184-A2-19/3.51	17.6	54.32	506.1	0.1798	382	549	455	630	512	693	558	749	3000	1700	830	1110	76	89
	IEC 315	363-A2-37/3.53	24.7	106.95	998.9	0.0916	573	834	686	959	772	1064	848	1151	3000	2000	960	1322	76	89
	IEC 400	460-A2-37/3.98	27.9	135.81	1268.4	0.0721	676	988	813	1133	911	1252	994	1362	3000	2300	1270	1452	76	89

ESKOM COPYRIGHT PROTECTED

	IEC 450	518-A2-37/4.22	29.6	152.79	1426.9	0.0641	734	1074	883	1233	989	1363	1078	1481	3000	2500	1450	1452	76	89
	IEC 500	575-A2-37/4.45	31.2	169.76	1585.5	0.0577	790	1160	945	1332	1063	1480	1161	1601	3000	2500	1450	1452	76	89
	IEC 560	645-A2-61/3.67	33	190.14	1778.4	0.0516	850	1254	1018	1441	1145	1601	1248	1737	2000	2300	1270	1452	76	89
	IEC 630	725-A2-61/3.89	35	213.9	2000.7	0.0458	918	1364	1102	1575	1237	1744	1351	1887	2000	2500	1450	1452	76	89
	IEC 710	817-A2-61/4.13	37.2	241.07	2254.8	0.0407	997	1489	1202	1718	1351	1903	1475	2059	2000	2500	1450	1452	76	89
	IEC 800	921-A2-61/4.38	39.5	271.62	2540.6	0.0361	1093	1622	1318	1863	1480	2066	1611	2244	1500	2500	1450	1452	76	89
AAC (insulated and non- insulated)	Hornet	157.62-A1-19/3.25	16.25	26	435	0.1825	357	510	427	584	478	647	524	700	1500	1500	1650	800	1066	166
	Centipede	415.22-A1-37/3.78	26.46	67.2	1150	0.0694	695	975	816	1121	913	1242	1002	1349	1000	1000	1900	960	1290	76
	Bull	865.36-A1-61/4.25	38.25	139	2400	0.0334	1150	1654	1365	1900	1517	2117	1660	2291	1000	1000	2250	1200	1102	202

- Note:**
1. the above table shows typical parameters for drum sizes conductor drum lengths and sizes are subject to change. All drum designs must be submitted to Eskom for Acceptance.
 2. Ampacity values are obtained from Determination of conductor ratings in Eskom – 240-147806256

Annex D – Typical size wooden drum showing Eskom branded flange

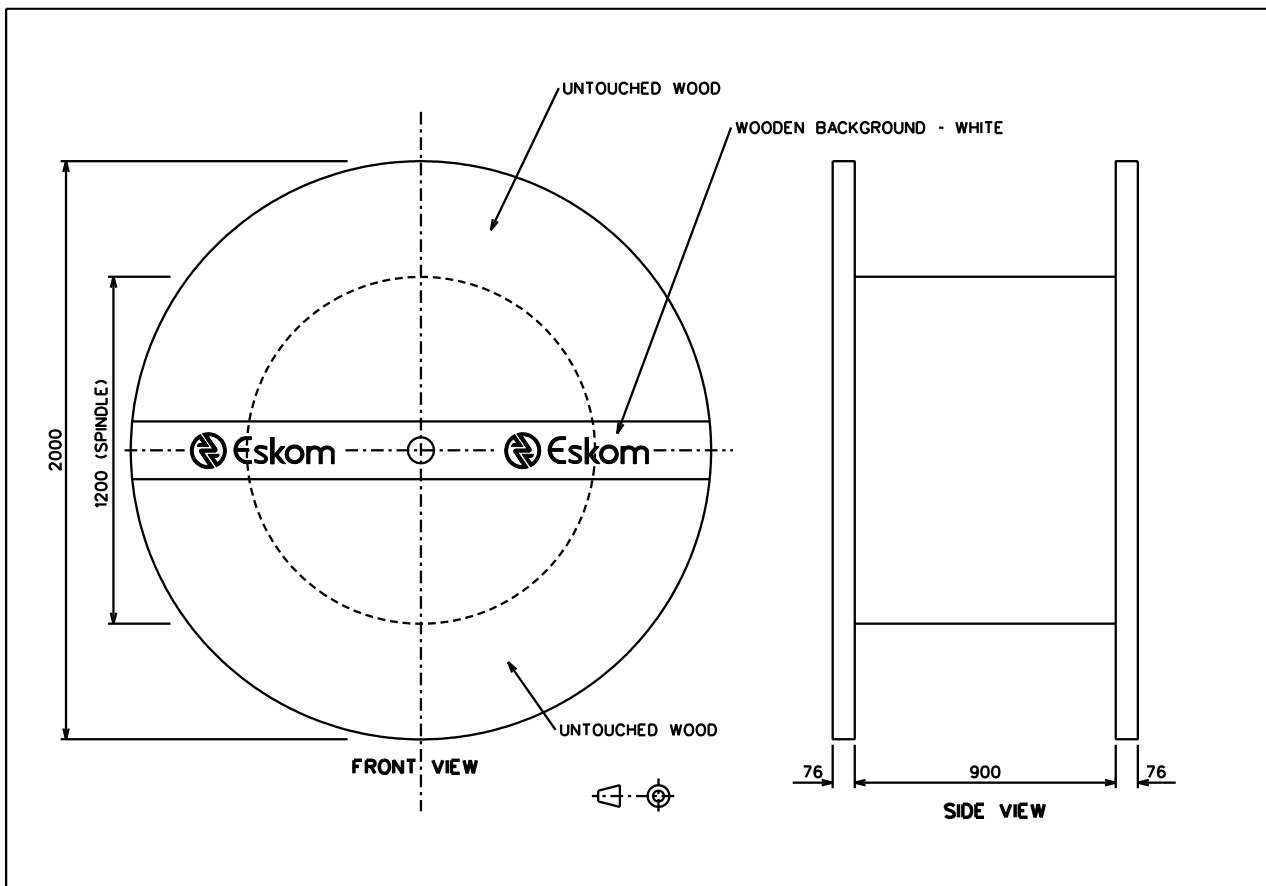

The Eskom Signature (logo and logotype) printing guide

The Eskom Signature (logo and logotype) must be used together as a unit. The logo (“circle”) and the logotype (the word “Eskom”) must always appear together as one unit.

a) Colour specifications:

The corporate signature may only appear in the **Eskom corporate blue** or in **black** or in **white**.

- Pantone 287C
- 100%C + 70%M + 0%Y + 10%K

To match colours, swatches must always be used. Previously printed material must never be used for colour matching.

b) Corporate signature isolation area:

There should always be a minimum clear area around the signature. This minimum is equal to the full diameter of the logo (“circle”).

c) Relationship between the logo and the logotype:

The relationship between the logo and the logotype must always be followed exactly as indicated in the graphic. The measurement between the logo (“circle”) and the logotype (word “Eskom”) is twice the line-width of the “circle”.

For more information please refer to: Corporate Identity Manual (ESKAMAAA1).