

Valid for 4 weeks from 2022-07-02 10:00:00

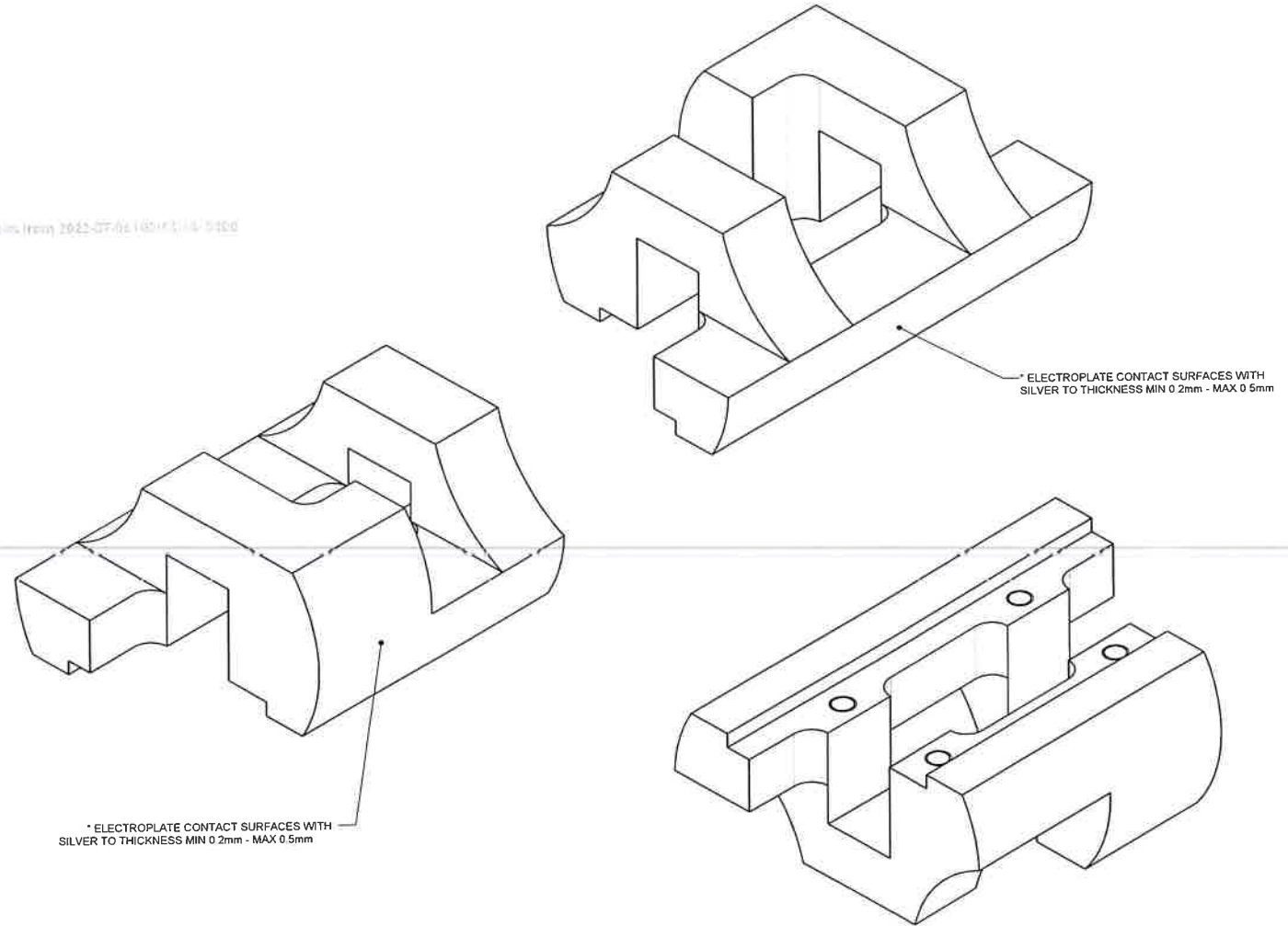

SPEC COPPER BILLET Ø105 x 105 TO BE USED FOR MACHINING C11000/ASTM B272 ELECTROLYTIC TOUGH PITCH COPPER

AMENDMENTS	
MASS	2.34 Kg

COPYRIGHT THIS DRAWING TOGETHER WITH THE COPYRIGHT IS THE PROPERTY OF TRANSNET THIS DRAWING OR ANY PART THEREOF IS NOT TO BE COPIED OR OTHERWISE REPRODUCED OR USED FOR MANUFACTURE OR ANY OTHER PURPOSE WITHOUT THE WRITTEN PERMISSION FROM CHIEF EXECUTIVE TRANSNET ENGINEERING	ASSEMBLY DRG No PELG_7220005-	DRAWN	M.L.C.	KILNER PARK LOCOMOTIVES <b>CONTACT ROTARY BLOCK</b> CONTACT ROTARY ASM	MATERIAL COPPER C101/CW004A OR SIMILAR COPPER BILLET (MACHINING) 153
	CLASS 18E LOCOMOTIVE	CHECKED	M.L.C.		
	TYPE MOT, RHEO DRUM	DATE	2020/03/10		
		SCALE	1:1		
A-1 PROJECTION	DOCUMENT REFERENCE No	PD_PELG_KLP_ORW_722	TRANSNET ENGINEERING	No	SHEET 1 OF 1 <b>KDSG 001A 0027</b>