

ANNEXURE B

RESTRICTED

gsn

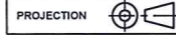

IF IN DOUBT ASK

DO NOT SCALE

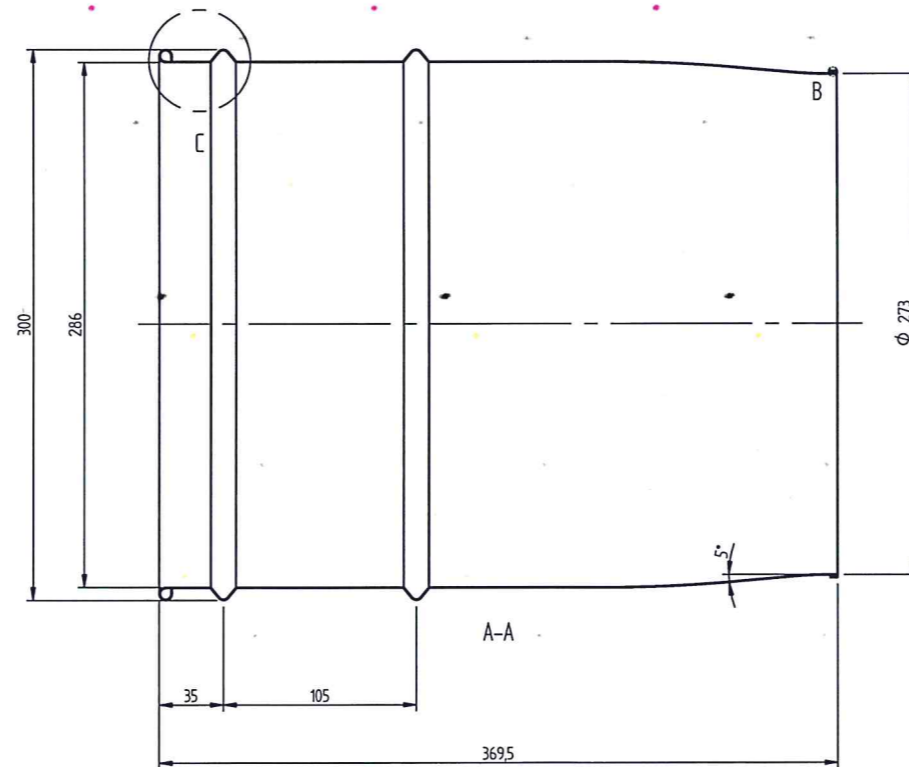
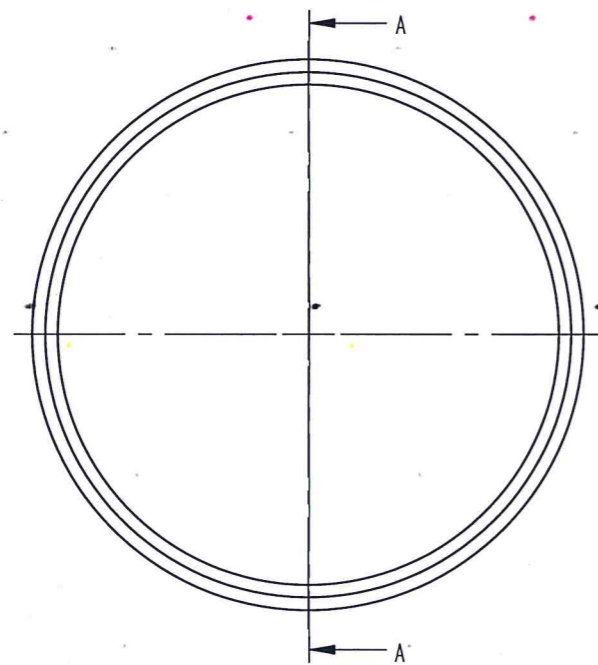
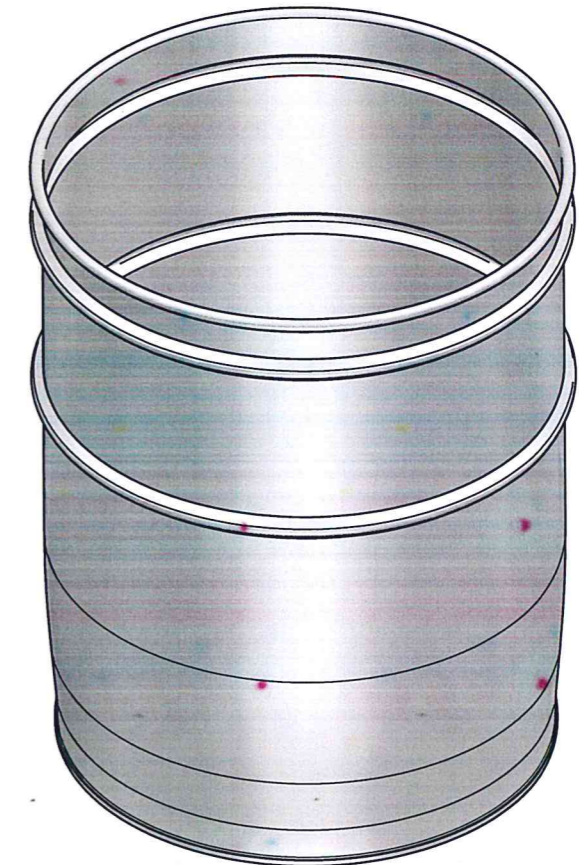
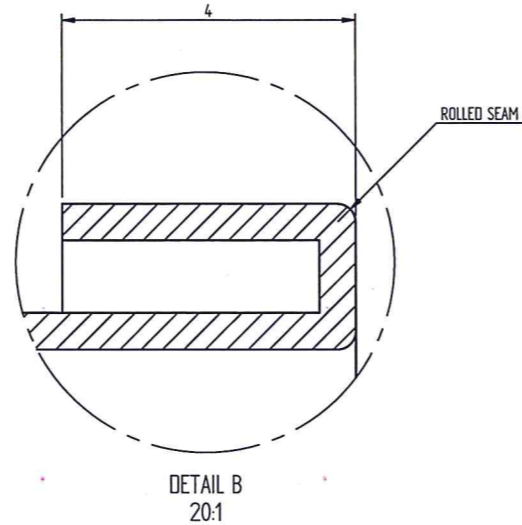
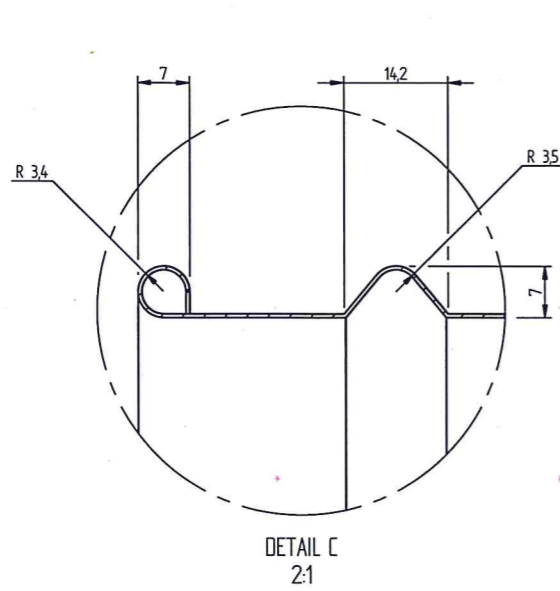

MATL: PLATE 0.5 THK, MILD STEEL

REV	ZONE	DESCRIPTION	CHK	DATE	REV	ZONE	DESCRIPTION	CHK	DATE	UNLESS OTHERWISE STATED REMOVE ALL SHARP EDGES SURFACE TEXTURE: $\sqrt{3.2}$ μm SCREW THREAD: ISO 6H 6g	MACH TOLERANCES UNLESS OTHERWISE STATED	ORIGINAL SCALE	1:2	ITEM	QTY	DESCRIPTION	MATERIAL/REMARK	DETAILS/SUB DRAWING NO
R1		ISSUED FOR APPROVAL								GEOMETRIC TOL BS 308 1972	OVER-TO TOL 0-6 ±0.1 6-30 ±0.2 35-100 ±0.3 100-300 ±0.5 300-1000 ±0.8 1000-3000 ±1.2 3000 PLUS ±2.0 ANGLES ±1°	UNITS mm	DRAWN GSN			P 1701 20L DRUM	NTP Actively enhancing life	R1
										WELD SYMBOLS BS EN 22553:1995		CHECKED			φ 286 DRUM	DRG No	H 5201-00-01	REVISION
										FIRST ISSUE		DATE						

COPYRIGHT
THIS DRAWING IS THE PROPERTY OF NTP RADIOISOTOPES (Pty) Ltd AND MAY NOT, WITHOUT THE WRITTEN AUTHORITY OF NTP BE COPIED OR COMMUNICATED TO A THIRD PARTY OR USED EITHER WHOLLY OR IN PART FOR ANY PURPOSE OTHER THAN THAT FOR WHICH IT IS SUPPLIED