

Polymer Concrete Cover & Frame: Type 2A

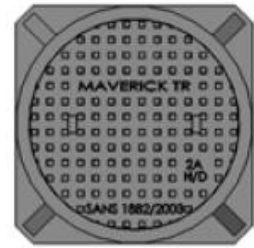

2A

sewer cover & frame

© MAVERICK TRADING. ALL RIGHTS RESERVED.

SANS 1882:2003 | Permit nr:8101/12893

PRODUCT CODES:

COVER: C0103N00CG

FRAME: FR103CG

Specifications

DESCRIPTION:	2A Polymer Manhole cover and frame to SABS Specification Sans 1882/2003
DIMENSIONS:	600mm diameter for more details see drawings
WEIGHT:	Frame 23kg ,Cover 40.60kg
FORCE:	135kn
USAGE:	Telecommunication, stormwater, sewer, valve, meter and bulkwater chambers
DUTY CLASS:	Heavy Duty
OPTIONAL:	Stainless steel, Ms hot dip galvanised & Fibre plastic patented lock and key
VARIATIONS:	Stainless steel, Ms hot dip galvanised & Fibre plastic patented lock and key
COLOURS:	As per customer requirements
COVER BRANDING:	As per customer requirements
CURRENT USERS:	All Municipals, Telecommunication, Civils and Telecom Namibia

Drawings

COVER: Type 2A Lockable

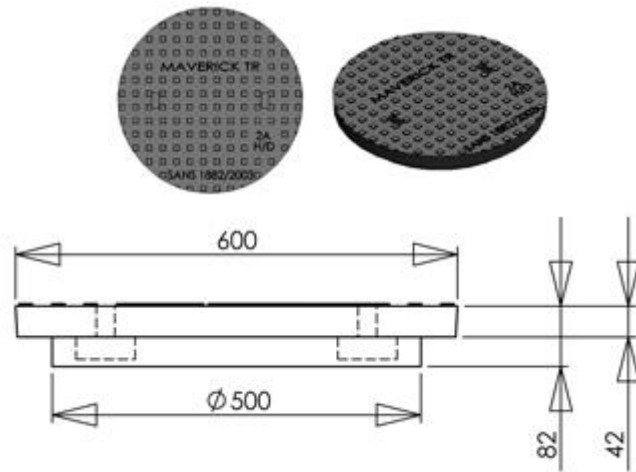

FRAME: Type 2A Lockable

