

CLUSTER
TRADING SERVICES
UNIT
ETHEKWINI ELECTRICITY
DEPARTMENT
TECHNICAL SUPPORT

PROCUREMENT DOCUMENT
GOODS/SERVICES

Documents are to be obtained, free of charge, in electronic format, from the [National Treasury's eTenders website](#) or the [eThekwini Municipality's website](#).

Tender No: 29023-(5E)

Title: SUPPLY, DELIVERY AND OFF-LOADING OF STAYWIRES AND ASSOCIATED COMPONENTS DURING A THIRTY-SIX MONTH PERIOD

CLARIFICATION MEETING AND QUERIES

Clarification Meeting: There will be no clarification meeting.

Queries can be Email queries to be submitted by 16 May 2024 and consolidated answers addressed to: to questions will be uploaded 23 May 2024

General / Contractual: [Nyaniso Mlilo](#); Tel: 031 311 9422; eMail: Nyaniso.Mlilo@durban.gov.za

Technical: [Nazeer Vawda](#); Tel: 031 311 9635; eMail: Nazeer.Vawda@durban.gov.za

DELIVERY OF TENDERS

Sealed Tenders, addressed to the City Manager and marked with the Tender Number, are to be placed in the Tender Box **located in the ground floor foyer of the Municipal Building, 166 KE Masinga Road (Old Fort Road), Durban** (and not any other municipal department), no later than:

Closing Date: Friday, 31 May 2024

Time: 11:00am

FACSIMILE, eMAIL or POSTED TENDERS WILL NOT BE ACCEPTED

Issued by:

ETHEKWINI MUNICIPALITY

Deputy Head: **TECHNICAL SUPPORT**

Issued: April 2024

Document Version: 24/02/2023

NAME OF TENDERER:

Tender Price: R

VAT Registered: YES / NO
(circle applicable)

PROCUREMENT DOCUMENT (Goods/Services)**INDEX**

Section		Page
1)	General Information.....	2
2)	Conditions of Tender (Goods/Services: July 2016).....	4
3)	Special/Additional Conditions of Tender	10
4)	Returnable Tender Documents	25
5)	General Conditions of Contract (NT Circular 52: July 2010)	41
6)	Special/Additional Conditions of Contract	48
7)	Scope and Specification of Required Supply/Services	51
8)	Bill of Quantities and Schedule of Rates	58
9)	Official Tender Form.....	59

SECTION 1: GENERAL INFORMATION

YOU ARE HEREBY INVITED TO TENDER FOR REQUIREMENTS OF THE ETHEKWINI MUNICIPALITY
--

TENDER No.: 29023-(5E)

DESCRIPTION: **SUPPLY, DELIVERY AND OFF-LOADING OF STAYWIRES AND ASSOCIATED COMPONENTS DURING A THIRTY-SIX MONTH PERIOD**

CLOSING DATE / TIME: Friday, 31 May 2024 at 11:00am

All tenders must be submitted on official tender documentation issued (in electronic format) by the eThekwini Municipality from:

- the National Treasury's eTenders website (<https://www.etenders.gov.za/>), or
- the eThekwini Municipality's website (<https://www.durban.gov.za/pages/business/procurement>).

Electronically downloaded documentation should be printed by the tenderer.

Tenderers are required to be registered on the **National Treasury Central Supplier Database (CSD)** as a service provider. In the case of a Joint Venture, this requirement will apply individually to each party in the Joint Venture.

Registration on the **eThekwini Municipality's Database** can be done via website: <https://ethekwinvendor.durban.gov.za/>

Tenderers should ensure that tenders are delivered timeously to the correct address as stated in the Conditions of Tender. If a tender is late, it will not be accepted for consideration.

The Municipality will consider a tender submitted in response to this request for tender to be an offer from your company to perform the supply on the basis of that tender. Accordingly, please review the attached General and Special Terms and Conditions which will form the basis for any supply arrangement entered into between the Municipality and your company.

The Municipality is seeking tenders from potential suppliers only and makes no representation or promise in relation to procuring work from a supplier or suppliers. The Municipality will not be responsible for any costs associated with preparing and submitting a tender.

The Municipality does not bind itself to accept the lowest or any tender. It reserves the right to accept the whole or any part of a tender to place orders. Bidders shall not bind the Municipality to any minimum quantity per order. The successful Tenderer (s) shall be bound to provide any quantities stipulated in the specification.

The successful tenderer will be required to fill in and sign a written Contract Form (MBD 7).

NB: NO TENDER WILL BE CONSIDERED FROM PERSONS IN THE SERVICE OF THE STATE (as defined in Regulation 44 of the Local Government: Municipal Supply Chain Management Regulations).

**THE FOLLOWING PARTICULARS MUST BE FURNISHED
(Failure to do so may result in your tender being disqualified)**

Name of Tenderer:

Postal Address:

Street Address:

E-Mail Address:

Telephone Number:

--	--	--

 -

--	--	--

 -

--	--	--	--

Cell phone Number:

--	--	--

 -

--	--	--

 -

--	--	--	--

Facsimile Number:

--	--	--

 -

--	--	--

 -

--	--	--	--

Circle Applicable

Is your entity registered on the **eThekweni Municipality’s supplier database?** YES / NO

• **If YES insert** your PR Number: **PR**

Is your entity registered on the **National Treasury Central Supplier Database (CSD)?** YES / NO

• **If YES, insert** your MAAA Number: **MAAA**

Insert a SARS Tax Compliance Status PIN

Is your entity VAT registered? YES / NO

• **If YES insert** Vat Registration Number:

Has a **Declaration of Municipal Fees** been submitted? YES / NO

Has a **Declaration of Interest** (MBD 4) been submitted? YES / NO

Has a **Declaration for Procurement Above R10 Million** (MBD 5) been submitted? YES / NO

Has a **Preference Points Claim** (MBD 6.1) been submitted? YES / NO

Has a **Declaration of Bidder’s Past SCM Practices** (MBD 8) been submitted? YES / NO

Has a **Certificate of Independent Bid Determination** (MBD 9) been submitted? YES / NO

Are you the accredited representative in South Africa for the goods / services / works offered? **If YES, enclose proof** at the back of the tender submission. YES / NO

Signature of Tenderer: Date:

Name / Surname: (in block capitals)

Capacity under which this tender is signed:

SECTION 2 : CONDITIONS OF TENDER – (Goods / Services : June 2019)

INDEX

1. **DEFINITIONS**
2. **CONDITIONS OF TENDER & CONTRACT**
3. **TENDER INFORMATION**
 - (1) General
 - (2) Obtaining Tender Documents
 - (3) Queries Relating to this Tender
 - (4) Briefing Session (Clarification Meeting)
 - (5) Closing Date and Delivery of Tender Submissions
 - (6) Tender Validity and Withdrawal of Tenders
4. **RETURNABLE SCHEDULES, FORMS, CERTIFICATES**
 - (1) Authority of Signatory
 - (2) Tax Compliance Status PIN / Tax Clearance Certificate
 - (3) Declaration of Municipal Fees
 - (4) Health and Safety
 - (5) Municipal Bidding Documents
 - (a) MBD 4: Declaration of Interest
 - (b) MBD 5: Declaration for Procurement Above R10 Million
 - (c) MDB 6.1: Preference Points Claim
 - (d) MBD 8: Declaration of Bidder's Past Supply Chain Management Practices
 - (e) MBD 9: Certificate of Independent Bid Determination
 - (5) Official Tender Form
 - (6) Additional Schedules, Forms, or Certificates
5. **INFORMATION TO BE SUPPLIED RE SUB-CONTRACTORS**
6. **SAMPLES**
7. **MANUFACTURERS**
8. **CLARIFICATION**
9. **PRICING**
10. **ESTIMATED QUANTITIES**
11. **DELIVERY, RISK, PACKAGES, ETC**
12. **RATES OF EXCHANGE**
13. **IMPORT PERMITS**
14. **EVALUATION PROCESS**
15. **BRIBERY AND COMMUNICATION WITH COUNCILLORS / OFFICIALS**
16. **NEGOTIATIONS WITH PREFERRED TENDERERS**
17. **CANCELLATION OF TENDER PROCESS**
18. **ACCEPTANCE OF TENDER**
19. **PAYMENT and FACTORING**
20. **APPEAL PROCESS**

SPECIAL / ADDITIONAL CONDITIONS OF TENDER

STANDARD CONDITIONS OF TENDER (Goods / Services)

1. DEFINITIONS

General:

- (1) Defined words / phrases are printed in *Italic font*.
- (2) Definitions apply to the singular as well as the plural.
- (3) Any reference to the masculine gender shall be taken to include the feminine and any reference to the feminine gender shall be taken to include the masculine.
- (4) The words “bid” and “tender”, and “bidder” and “tenderer” can be used interchangeably.
- (5) All definitions as defined in the *General Conditions of Contract* are applicable to these *Standard Conditions of Tender*. These definitions include:
 - “Closing time”
 - “Contract”
 - “Contract Price”
 - “Corrupt practice”
 - “Countervailing duties”
 - “Country of origin”
 - “Day”
 - “Delivery”
 - “Delivery ex stock”
 - “Delivery into consignees store or to his site”
 - “Dumping”
 - “Force majeure”
 - “Fraudulent practice”
 - “GCC”
 - “Goods”
 - “Imported content”
 - “Local content”
 - “Manufacture”
 - “Order”
 - “Project site”
 - “Purchaser”
 - “Republic”
 - “SCC”
 - “Services”
 - “Supplier”
 - “Tort”
 - “Turnkey”
 - “Written” or “in writing”
- (6) **Bid or Tender:** The offer submitted in respect of an invitation to submit such an offer.
- (7) **Bidder or Tenderer:** An entity (company, close corporation, partnership, joint venture, sole proprietor) which submits a *bid/tender*.
- (8) **Municipality:** The eThekweni Municipality, as represented by the duly authorised delegate, official or committee.
- (9) **SCT:** Special Conditions of Tender (found in Section 3).
- (10) **Week:** A period of seven (7) consecutive *days*.
- (11) **Material Deviation:** A material deviation or qualification is one which, in the *Municipality’s* opinion, would:
 - (a) Detrimentally affect the scope, quality, or performance of the services or supply identified in the Scope;
 - (b) Significantly change the *Municipality’s* or the *Tenderer’s* risks and responsibilities under the contract; or
 - (c) Affect the competitive position of other *Tenderers* presenting responsive *tenders*, if it were to be rectified.

2. CONDITIONS OF TENDER & CONTRACT

The specification will be governed by the *Standard Conditions of Tender* (Goods and Services), *Special Conditions of Tender (SCT)*, *General Conditions of Contract (GCC)* (Government Procurement General Conditions (July 2010), as amended by National Treasury Circular 52 dated 30 July 2010), the *Special Conditions of Contract (SCC)*, the *Occupational Health and Safety Act* (Act No. 85 of 1993), and the *eThekweni Code of Conduct*.

Complete Acceptance of Conditions

Unless otherwise expressly stipulated in a letter covering the *tender*, every *Tenderer* shall be deemed to have waived, renounced, and abandoned any conditions printed or written upon any stationery used for the purpose of, or in connection with, the submission of their *tender*, which are in conflict with the *General Conditions of Contract* and *Special Conditions of Contract*. *Tenderers* are advised that any *material divergences / qualifications* from the official Conditions or Specification will render their *tenders* liable to disqualification.

3. TENDER INFORMATION

(1) General

- (a) *Tenders* will be liable for rejection unless made out on the official tendering documentation.
- (b) Any alterations effected upon any of the tendering documents must be clearly shown by means of a hand written (black, non-erasable ink), or typed, entry and must be signed in full by the *Tenderer*. **The use of correction fluid is not permitted.**
- (c) *Tenderers* may submit alternative solutions that, in the *Tenderer’s* opinion, are to the *Municipality’s* advantage economically and technically. Full technical details of the alternative *tender(s)* shall be submitted with the tender documents. Alternative *tender(s)* shall be submitted separately.

(2) Obtaining Tender Documentation

All tenders must be submitted on official tender documentation issued, in electronic format, by the eThekweni Municipality. Electronically downloaded documentation (obtainable free of charge) should be printed and suitably bound by tenderer.

(3) Queries Relating to this Tender

Queries can be directed to the person / Department as stated in the *SCT*.

(4) Briefing Session (Clarification Meeting)

Details of the briefing session are stated in the *SCT*. Failure to attend a compulsory briefing session will invalidate the *tender*. *Tenderers* must sign the attendance list in the name of the tendering entity. Tenders will only be evaluated from those tendering entities appearing on the attendance list.

(5) Closing Date and Delivery of Tender Submissions

Sealed *tenders* made out on the enclosed Official Tender Form, which shall be signed by or on behalf of the *Tenderer*, and addressed to the City Manager, marked with the appropriate Tender number, must be placed in the **Tender Box** as stated in the *SCT* not later than the **date and time** as stated in the *SCT*, where after they will be opened publicly.

All tender documents **must** be placed directly into the Tender Box and should not be delivered to any other Municipal Department. *Bidders* are advised that *tenders* submitted by post, fax or email **will not** be considered. All couriered documents must be placed directly into the Tender Box and should not be delivered to any other Municipal Department.

Any *tender* received after the closing date and time stated for the receipt thereof **shall not** be accepted for consideration and shall be returned to the *Tenderer*.

(6) Tender Validity and Withdrawal of Tenders

Tenders must hold good until 16:00 of the 5th week following the date on which *tenders* are opened, or during such other period as may be specified in the *SCT*. The *Municipality* may, during the period for which *tenders* are to remain open for acceptance, authorize a *Tenderer* to withdraw their *tender* in whole or in part on condition that the *Tenderer* pays to the *Municipality* on demand, a sum of one thousand Rand (R1,000.00). The *Municipality* may, if it thinks fit, waive payment of such sum in whole or in part.

4. RETURNABLE SCHEDULES, FORMS, CERTIFICATES

Each *Tenderer* shall complete fully and accurately the following documents and submit these documents with the *tender*:

- (1) **Authority of Signatory:** In terms of Clause 4(5)(c) of the Conditions of Tender.
- (2) **Tax Compliance Status PIN / Tax Clearance Certificate:** SARS has introduced a new Tax Compliance Status System. Tenderers can submit a Tax Compliance Status PIN (TCS PIN) instead of an original Tax Clearance Certificate. This TCS PIN can be used by third parties to certify the taxpayer's real-time compliance status.
- (3) **Declaration of Municipal Fees:** Only those *Bidders* whose municipal fees are fully paid, or those that have concluded acknowledgement of debt agreements with the *Municipality*, are eligible to *tender*.
All *Bidders* must sign the Declaration of Municipal Fees returnable form, declaring that their municipal fees are in order or that acknowledgement of debt agreements have been concluded, and include the relevant account numbers in the declaration. Failure to include account numbers or sign will invalidate the *tender*. The completion of the declaration is also applicable to *Bidders* outside of the eThekweni Municipal Area.
- (4) **Declaration with respect to the Occupational Health and Safety Act:** Acceptance of undertaking in terms of the Occupational Health and Safety Act (Act 85 of 1993) and the relevant Regulations.

(5) Municipal Bidding Documents (which includes):

- (a) **MBD 4: Declaration of Interest:** All *Bidders* are to sign the Declaration of Interest wherein they declare any relationship that may exist with an official of the Municipality involved in the evaluation process.
Regulation 44 of the Supply Chain Management Regulations states that a Municipality or Municipal Entity may not make any award to a person:
 - (i) Who is in the service of the state;
 - (ii) If that person is not a natural person, of which any Director, Manager, Principal, Shareholder or Stakeholder is a person in the service of the state; or
 - (iii) Who is an advisor or consultant contracted with the Municipality or municipal entity.
 Should a contract be awarded, and it is subsequently established that Regulation 44 has been breached, the Municipality shall have the right to terminate the contract with immediate effect.
- (b) **MBD 5: Declaration for Procurement Above R10 Million (if applicable):** For all procurement expected to exceed R10 million (all applicable taxes included), tenderers must complete this questionnaire.
- (c) **MBD 6.1: Preference Points Claim Form:** For the awarding of Preference Points, *Bidders* are required to complete the attached MBD 6.1 form and return it with their tender submission. Failure on the part of a tenderer to complete and submit this form will be interpreted to mean that preference points for **Specific Goals** are not claimed.
The Municipality reserves the right to require of a tenderer, either before a bid is adjudicated or at any time subsequently, to substantiate any claim in regard to preferences, in any manner required by the Municipality.
- (d) **MBD 8: Declaration of Bidders Past Supply Chain Management Practices Form:** This form serves as a declaration to be used by municipalities and municipal entities in ensuring that when goods and services are being procured, all reasonable steps are taken to combat the abuse of the supply chain management system.
- (e) **MBD 9: Certificate of Independent Bid Determination:** Section 4(1)(b)(iii) of the Competition Act No. 89 of 1998, as amended, prohibits an agreement between, or concerted practice by, firms if it involves collusive tendering or tender rigging. In order to give effect to this, the Certificate of Bid Determination must be completed and submitted with the tender.

(5) **Official Tender Form** (see Section 9)**(a) Legal Status of Tenderer**

It is essential for the purpose of entering into a legal contract that *Bidders* state on the Official Tender Form, under "Name and Address of Tenderer ", their full legal status:

- (i) the full registered name of the company making a *tender*; or
- (ii) if the *Tenderer* is a person conducting business under a recognised trading name then:
 - State the name of the person(s);
 - State recognised trading name; and
 - State whether an owner, co-owner, proprietor, etc.

(b) Signing of Official Tender Form

Failure of a *Tenderer* to complete, in its entirety, and sign the Official Tender Form will invalidate the *tender*.

(c) Authority of Signatory

Bidders are to complete and sign the Authority of Signatory returnable document, and attach the required additional documents.

(d) Differences or Discrepancies

Should there be any difference or discrepancy between the prices or price contained in the Official Tender Form and those contained in any covering letter from the *Tenderer*, the prices or price contained in the Official Tender Form shall prevail.

(6) **Any additional Schedules, Forms, or Certificates as stated in the SCT.**5. **INFORMATION TO BE SUPPLIED REGARDING SUB-CONTRACTORS**

Bidders are to state in their *tenders*, or covering letters, whether, if the contract were to be awarded to them, the whole of the work would be executed by them in their own workshop / factory. If the answer is in the negative, they are required to state which part(s) would be handed to sub-contractors and the name and address of such sub-contractors.

6. **SAMPLES**

Bidders may be required to state where samples of the full range of products can be inspected or be required to submit samples for inspection prior to the closing date of the *tender*.

7. **MANUFACTURERS**

The names of the manufacturers of the goods or equipment offered must be stated in the *tender*.

Bidders who are not manufacturers, accredited distributors, or agents must provide a valid agreement / Joint Venture Agreement, entered into with the manufacturer, accredited distributors, or agents, with their submission. This agreement must meet all the requirements as laid down in the *tender* document, and must cover the contract period.

8. **CLARIFICATION**

The Head: Supply Chain Management Unit, or an authorized representative, may request clarification or further information on any aspect of the *tender*. The *Tenderer* **must** supply the requested information within the time specified. Failure to comply will render the *tender* non-responsive.

9. **PRICING**

Bidders would be precluded from this *tender* if their pricing structure deviates from the Official Tender Form.

(1) **Nett Prices**

All prices shall be quoted in South African currency (Rand) after deduction of any brokerage or discount allowed to the Municipality.

(2) **Unit Prices**

Bidders shall quote only one price in respect of each item. Such price is to hold good for the full duration of the contract period, being subject to variation only in accordance with specified criteria, as stated in the **Conditions of Contract**.

(3) **Firm Tenders**

Bidders may submit firm prices for each 12 month period. These prices shall be free from all fluctuations, including any statutory increases.

(4) **Value Added Tax (V.A.T)**

Prices exclusive and inclusive of VAT must be stated separately on the Official Tender Form.

10. **ESTIMATED QUANTITIES**

The estimated quantities are set out in Section 8 : Bill of Quantities / Schedule of Rates/Activities which forms part of the official tender documents. The quantities are stated purely for the information of the *Bidders* and are in order to ascertain an estimated total contract price. The *Supplier* will, however, be bound to supply whatever quantity or quantities the *Municipality* may actually require, and may exceed, or be less than, the estimated quantities stated.

11. **DELIVERY, RISK, PACKAGES, ETC**

(1) Unless otherwise provided, all goods are to be supplied only against the form of order issued by the *Municipality*.

(2) *Bidders* shall quote a unit price which shall include delivery to the specified delivery point, as stated in the **SCT**.

(3) The risk in all goods purchased by the *Municipality* under the contract shall remain with the *Supplier* until such goods shall have been duly delivered.

(4) *Bidders* shall clearly state the period within which delivery will be made after receipt of the official order, as this may be material in the adjudication of the *tender*.

12. RATES OF EXCHANGE

- (1) Where the goods are imported the *Supplier* shall, within seven days of date of official Purchase Order, arrange through their bankers for the foreign commitment to be covered forward down to the Rand in order to fix the rate of exchange. The *Supplier* shall notify the *Municipality* as soon as possible thereafter regarding the rate which has been fixed on such forward exchange.

Any increase or decrease between the basic rate of exchange as at a date seven days prior to the date of closing of *tenders* and that existing at the date of establishment of the forward exchange cover within the period stipulated above shall be paid or deducted by the *Municipality*. Upon the failure of the *Supplier* to arrange forward exchange cover, the *Supplier* shall be liable should there be any increase in the basic rate of exchange occurring after the last mentioned date.

The bank charges incurred in obtaining the forward exchange cover shall be for the *Municipality's* account.

- (2) The *Supplier* shall on request:
- Submit documentary proof of the rate of exchange; and
 - When an adjustment is claimed in terms of this sub-clause, whether by the *Supplier* or the *Municipality*, submit documentary proof to the satisfaction of the Deputy City Manager: Treasury in respect of such claim.

13. IMPORT PERMITS

- (1) In order to minimise special importation, *Bidders* should, where possible, have recourse to local suppliers and / or manufacturers.
- (2) *Bidders* must state whether their *tender* is dependent upon the issue of a special import permit or whether they are able to supply the goods by making use of the import facilities available to them.
- (3) In the event of a tender being dependent upon the issue of a special import permit, application for such special import permit shall be made by the *Tenderer*, unless otherwise provided for in the *SCT*.

14. EVALUATION PROCESS

The procedure for evaluation of responsive Tender Offers will be in accordance with the eThekweni Municipality's current SCM Policy and the Preferential Procurement Policy Framework Act (5 of 2000), and the Preferential Procurement Policy Framework Act Regulations (November 2022).

Details of additional evaluation criteria, if applicable, are stated in the *SCT*.

Evaluation points for price and preference will only be calculated for *Bidders* who comply with the contractual and technical specification, and if applicable, have attained the minimum Functionality Score as stated in the *SCT*.

The evaluation process of responsive *tenders* will be as follows:

- Score each *tender* in respect of the financial offer made and preferences claimed (if any);
- Calculate the total number of evaluation points (T_{EV}) in accordance with the following formula:
 $T_{EV} = N_{FO} + N_P$ where: N_{FO} : is the number of evaluation points awarded for the financial offer; and N_P : is the number of evaluation points awarded for preferences claimed.
- Rank *tenders* from the highest number of evaluation points to the lowest.
- Recommend the *Tenderer* with the highest number of evaluation points for the award of the contract, unless there are compelling and justifiable reasons not to do so.
- Rescore and re-rank all *Bidders* should there be compelling and justifiable reasons not to recommend the *Tenderer* with the highest number of evaluation points, and recommend the *Tenderer* with the highest number of evaluation points, unless there are compelling and justifiable reasons not to do so, and the process set out in this sub-clause is repeated.

(1) Evaluation points awarded for the financial offer:

Reference is to be made to the Special Conditions of Tender (*SCT*), and returnable form 5(c) in Section 4.

INCOME-GENERATING CONTRACTS

The financial offer will be scored using the formula:

$$N_{FO} = W \left(1 + \frac{Pt - P_{max}}{P_{max}} \right)$$

GOODS and SERVICES

The financial offer will be scored using the formula:

$$N_{FO} = W \left(1 - \frac{Pt - P_{min}}{P_{min}} \right)$$

Where the value of W is:

- 90** where the financial value inclusive of VAT of all responsive *tenders* received have a value in excess of R 50,000,000; OR
80 where the financial value inclusive of VAT of one or more responsive *tenders* offers have a value that equals or is less than R 50,000,000.
It is unclear (at the time of advertising) which of the two preference point systems applies. Either the 80/20 or 90/10 preference point system will apply, determined by the price offered by the lowest acceptable tender.

(b) **P_{max}** is the comparative offer of the most favourable comparative offer (highest acceptable tender).

(c) **P_{min}** is the comparative offer of the most favourable comparative offer (lowest acceptable tender).

(d) **P_t** is the comparative offer of the *tender* offer under consideration.

(2) Evaluation points awarded for preference:

The **Specific Goals** for Preference Points are specified in the *SCT*.

15. BRIBERY AND COMMUNICATION WITH COUNCILLORS / OFFICIALS

(1) **Bribery**

No *Tenderer* shall offer, promise or give to any person or person connected with a *tender* or the awarding of a contract, any gratuity, bonus or discount etc, in connection with the obtaining of a contract.

(2) **Communication, Councillors and Officials**

A *Tenderer* shall not in any way communicate with a member of the *Municipality* or with any official of the *Municipality* on a question affecting any contract for the supply of goods or for any work, undertaking or services which is the subject of a *tender* during the period between the closing date for receipt of *tenders* and the dispatch of the written notification of the *Municipality's* decision on the award of the contract; provided that a *Tenderer* shall not hereby be precluded:

- (a) At the request of the Head: SCM Unit, or an authorized representative, from furnishing him with additional information or with a sample or specimen for testing purposes or otherwise from giving a demonstration so as to enable the recommendation to the Bid Committee on the award of the contract to be formulated;
- (b) From obtaining from the Head : SCM Unit, or an authorised representative, information as to the date upon which the award of the contract is likely to be made, or, after the decision upon the award has been made by the *Municipality* or any Committee to which the *Municipality* has delegated its powers, information as to the nature of the decision or such information as was publicly disclosed at the opening of *tenders* or from submitting to the Accounting Officer in writing any communication relating to their *tender* or the award of the contract or a request for leave to withdraw their *tender*; and
- (c) Provided further that nothing contained herein shall be construed so as to prevent information being sought and obtained from an Official in regard to any decision taken at an open Municipal meeting, or any Committee to which the *Municipality* has delegated its powers.

A contravention of subsection (1) and / or (2), or an attempt to contravene such subsection, shall be reported to the Accounting Officer, who may on receipt of such report disqualify the *tender* of the *Tenderer* concerned.

16. NEGOTIATIONS WITH PREFERRED BIDDERS

The *Municipality* reserves the right to invoke Regulation 24 of Municipal Finance Management Act if required.

- (1) The Accounting Officer may negotiate the final terms of a contract with *Bidders* identified through a competitive tendering process as preferred *Bidders*, provided that such negotiation:

- Does not allow any preferred *Tenderer* a second or unfair opportunity;
- Is not to the detriment of any other *Tenderer* ; and
- Does not lead to a higher price than the *tender* as submitted.

- (2) Minutes of such negotiations must be kept for record purposes.

- (3) Such negotiation may be delegated by the Accounting Officer.

17. CANCELLATION OF TENDER PROCESS

The municipality is entitled to cancel the tender at any time before the award of a tender and the decision to cancel the tender shall be published in the same manner in which the original tender invitation was advertised. The Municipality shall, in no way, be liable for any damages whatsoever, including, without limitation, damages for loss of profit, in any way connected with the cancellation of this bid.

18. ACCEPTANCE OF BID

- (1) The *Municipality* does not bind itself to accept the lowest or any *tender*, and reserves the right to accept the whole or any part of a *tender* to place orders.
- (2) The *Municipality* reserves the right to accept more than one technically and contractually compliant *tender* for part or the whole of the contract and to place orders on the price and availability.
- (3) *Bidders* shall not bind the *Municipality* to any minimum quantity per order.
- (4) The successful *Tenderer (s)* shall be bound to provide any quantities stipulated in the specification.
- (5) Tenders will only be accepted on condition that:
 - (a) The *tender* is signed by a person authorised to sign on behalf of the *Tenderer* .
 - (b) A valid (at time of close of tenders), original, Tax Clearance Certificate OR Tax Compliance Status PIN is included with the *tender* submission. Both should have sufficient validity to ensure the process is adequately covered;
 - (c) A *Tenderer* who submitted their *tender* as a Joint Venture has included an acceptable Joint Venture Agreement and a B-BBEE Certificate pertaining to the Joint Venture with their *tender*.
- (6) Financial Standing: The Head: Supply Chain Management reserves the right to require *Bidders* to submit evidence that their financial standing is adequate to meet their obligations under the contract should they be successful.
- (7) Change of Ownership or Major Policy: Where it is known to a *Tenderer* that a change in ownership or major policy (of the tendering entity) will occur, or is likely to occur, during a specified contract period, the scope and effect thereof must be fully defined in a covering letter to be submitted with the *tender*.
- (8) Purchase of Goods From Other Sources: Nothing contained in this contract shall be held to restrain the *Municipality* from purchasing from persons other than the *Supplier*, any of the goods described or referred to in this contract, if it shall in its discretion think fit to do so.
- (9) Capability and Breach of Contract: Tenderers that do not have the capability of undertaking this enquiry in terms of the requirements of the contract or have been in breach of contract previously will not be considered.

19. PAYMENT and FACTORING

Payment conditions will be as per the ***Conditions of Contract***.

Payment will be made only to the *Supplier(s)*. Factoring arrangements will not be accepted.

20. APPEALS

In terms of Regulation 49 of the Municipal Supply Chain Management Regulations persons aggrieved by decisions or actions taken by the *Municipality*, may lodge an appeal within 14 days of the decision or action, in writing to the *Municipality*. The appeal (clearly setting out the reasons for the appeal) and queries with regard to decision of award are to be directed to the office of the City Manager, attention:

Ms. S. Pillay, P.O. Box 1394, Durban, 4000;
eMail: Simone.Pillay@durban.gov.za.

SECTION 3: SPECIAL/ADDITIONAL CONDITIONS OF TENDER

3.1 SPECIAL CONDITIONS OF TENDER (SCT)

The ***Standard Conditions of Tender*** (Goods/Services) make several references to the ***Special Conditions of Tender*** (SCT) for details that apply specifically to this tender. The ***Special Conditions of Tender*** shall have precedence in the interpretation of any ambiguity or inconsistency between it and the ***Standard Conditions of Tender***.

Each item below is cross-referenced to the clause in the ***Standard Conditions of Tender*** to which it mainly applies.

SCT 3(1) TENDER INFORMATION: General

The tender document comprises of a cover page and 59 pages.

SCT 3(2) TENDER INFORMATION: Obtaining Tender Documentation

Documents are issued by the eThekweni Municipality in electronic format.

Electronically downloaded documentation is obtainable from:

- the National Treasury's eTenders website
 - (<https://www.etenders.gov.za/>), or
- the eThekweni Municipality's website
 - (<https://www.durban.gov.za/pages/business/procurement>).

The entire document should be printed on A4 paper (one sided), and suitably bound by the Tenderer.

SCT 3(3) TENDER INFORMATION: Queries Relating to this Tender

General and Contractual Queries are to be directed to:

Nyaniso Mliilo; Tel: 031 311 9422; eMail: Nyaniso.Mliilo@durban.gov.za

Technical Queries are to be directed to:

Nazeer Vawda; Tel: 031 311 9635; eMail: Nazeer.Vawda@durban.gov.za

SCT 3(4) TENDER INFORMATION: Briefing Session

There will be no clarification meeting.

SCT 3(5) TENDER INFORMATION: Closing Date and Delivery of Tender Submissions

Sealed Tenders, addressed to the City Manager and marked with the Tender Number, are to be placed in the Tender Box **located in the ground floor foyer of the Municipal Building, 166 KE Masinga Road (Old Fort Road), Durban** (and not any other municipal department), no later than: **Friday, 31 May 2024 at 11:00am.**

Bidders are to include, with their "hard copy" submission, a memory-stick containing an electronically scanned (300 dpi resolution) Public Document Format (PDF) copy of their complete bid submission. This PDF file should be named using the contract number and the bidder's name, eg. **"29023-(5E) – Tenderers Name.PDF"**. The memory-stick must be securely fixed to the paper submission.

An electronic submission via SSS. Bidders must ensure that the hard copy and electronic submission are the same, failing which the submission will be deemed invalid. Bidders are responsible for resolving all access rights and submission queries before the tender closing date.

Technical Queries SSS: Jabulani Chauke: 031-322 9535: Queries - email:

Jabulani.chauke@durban.gov.za

SSS Queries Contact Lindo Dlamini: Tel: 031-3227133/031-3227153 email: selfservice@durban.gov.za

- SCT 3(6) TENDER INFORMATION: Tender Validity and Withdrawal of Tenders**
Tenders must hold good for 120 days following the date on which tenders are opened.
- SCT 4(6) RETURNABLE SCHEDULES, FORMS, CERTIFICATES**
There are no additional returnable schedules or forms.
- SCT 11(2) DELIVERY, RISK, PACKAGES, ETC**
The cost of delivery shall be amortised into the bid price. No separate delivery costs shall be included. The specified delivery and off-loading point is eThekweni Electricity, Main Store, 11 Electron Road, (off Umgeni Road), Springfield, Durban.
- SCT 13 IMPORT PERMITS**
In the event of a tender being dependent upon the issue of a special import permit, application for such special import permit shall be made by the Tenderer.
- SCT 14 EVALUATION PROCESS**
- 14.1 Eligibility, Price and Preference**
The procedure for the evaluation of responsive tenders is **ELIGIBILITY, PRICE AND PREFERENCE** in accordance with the Employer's current SCM Policy, the Preferential Procurement Policy Framework Act (5 of 2000), and the Preferential Procurement Policy Framework Act Regulations (2022).
- a) **ELIGIBILITY**
All Tender offers will be assessed for eligibility against the technical specification for each item detailed in **SECTION 7** and the **RETURNABLE DOCUMENTS** of **ACT 9**.
- b) **PRICE**
The eligible Tender offers will then be reduced to a comparative **PRICE** schedule for each item detailed in **SECTION 8**.
- c) **PREFERENCE**
The **80/20** preference points system will be applied. The Formula used to calculate the **Price Points (max. 80)** will be according to that specified Regulation 5.1.
- 14.2 Preference Point System and Specific Goals**
The definitions as per the SCM Policy are applicable.
Preference Points (20) will be derived from points claimed on Returnable Document **MBD 6.1: "Preference Points Claim Form"** (in Section 4 of this procurement document) for the **Specific Goal(s)** as indicated on the table(s) below, and according to the specified **Goal Weightings**.

Ownership Goal

The tendering entity's **Percentage Ownership**, in terms of the **Ownership Category(s)** listed below, is to be used in the determination of the tenderer's claim for **Preference Points**.

Goal Weighting: 40%		
Ownership Categories	Criteria	80/20
Race: Black (100%)	0%	0
	>0% and <51%	8
	≥51% and <100%	15
	100%	20
Proof of claim as declared on MBD 6.1 (1 or more of the following will be used in verifying the Tenderer's status) <ul style="list-style-type: none"> • Companies and Intellectual Property Commission registration document (CIPC) • CSD report. • B-BBEE Certificate of the tendering entity. • Consolidated B-BBEE Certificate if the tendering entity is a Consortium, Joint Venture, or Trust (Issued by verification agency accredited by the South African Accreditation System). • Agreement for a Consortium, Joint Venture, or Trust. 		

RDP Goal: The promotion of South African owned enterprises

The tendering entity's **Address** (as stated on the National Treasury Central Supplier Database (CSD) or on the eThekweni Municipality Vendor Portal) is to be used in the determination of the tenderer's claim for **Preference Points** for this Specific Goal.

Goal Weighting 40%	
Location	80/20
Not in South Africa	0
South Africa	5
KZN	10
EThekweni Municipality	20
Proof of claim as declared on MBD 6.1 (1 or more of the following will be used in verifying the tenderer's status) <ul style="list-style-type: none"> • CSD report 	

RDP Goal: The promotion of export-oriented production to create jobs

The tendering entity's **Business Type**, in terms of the categories below, is to be used in the determination of the tenderer's claim for **Preference Points** for this Specific Goal.

Goal Weighting 20%	
Local content and production	80/20
Retailer	10
Distributor	15
Wholesaler	15
Manufacturer	20
Proof of claim as declared on MBD 6.1 (1 or more of the following will be used in verifying the tenderer's status) <ul style="list-style-type: none"> • SABS/ SANAS certification • CSD report 	

3.2 ADDITIONAL CONDITIONS OF TENDER (ACT)**ACT 1 ELIGIBILITY – CSD REGISTRATION**

Tenderers are required to be registered on the National Treasury Central Supplier Database (CSD) as a service provider. In the case of a Joint Venture, this requirement will apply individually to each party in the Joint Venture. Tenderers not so registered, at time of closing of tenders, will not be eligible to submit tenders.

The Tenderer's CSD Supplier Number (starting with "MAAA") is to be provided on the information table in Section 1.

Tenderers who wish to register on the CSD may do so via web address <https://secure.csd.gov.za>.

ACT 2 Tenderers shall submit:

- a) full technical and descriptive information as detailed in **SECTION 7**;
- b) **RETURNABLE DOCUMENTS 1 to 9** and **DELIVERY PERIODS SCHEDULE** as detailed in **ACT 9**; and
- c) relevant technical datasheets for the tendered items.

ACT 3 The preferred Tenderers shall submit samples of the tendered items within one (1) week of request by eThekweni Electricity. These samples shall be delivered to eThekweni Electricity, Technology Services, 3rd Floor Smart Xchange Building, 5 Walnut Road, Durban, marked for the attention of Nazeer Vawda – Senior Engineer: Technology Services.

ACT 4 The samples submitted by Tenderers for each item shall be identical to the items offered on the respective **RETURNABLE DOCUMENTS 1 to 9** detailed in **ACT 9** and shall be labelled with the following information:

- a) Contract/Enquiry number;
- b) Name of Tenderer;
- c) Date of delivery; and
- d) Item number corresponding with the respective **RETURNABLE DOCUMENT**.

ACT 5 Tenderers shall bear full costs of the samples provided. EThekweni Municipality shall not be held liable for the costs incurred by the Tenderer.

ACT 6 EThekweni Electricity reserves the right to submit samples to tests as deemed reasonable and necessary. Tenderers shall collect and remove their samples within one month of being notified to do so, failing which they will be deemed to have waived all rights to the samples and such samples not collected after one month from the date of such notification will become the property of the eThekweni Municipality for disposal or use at its discretion.

ACT 7 TENDER AWARD

The tender shall be awarded on a per item basis. EThekweni Municipality may accept more than one responsive tender per item. This may include, and is not limited to, the award of tenders where the tendered items are from different manufacturers. This may be done to mitigate risk of supply if deemed necessary. Orders shall be placed on the basis of price and availability.

ACT 8 Tenderers shall not bind eThekweni Municipality to any minimum quantity per order.

ACT 9 RETURNABLE DOCUMENTS, SCHEDULES AND DECLARATIONS

This section contains the following documents:

- a) **ITEM NO., STOCK CODE, DESCRIPTION AND ESTIMATED QUANTITY SCHEDULE** which serves for information purposes only;
- b) **RETURNABLE DOCUMENTS 1 to 9** which details the technical requirements for each item; and
- c) **DELIVERY PERIODS SCHEDULE** which details eThekweni Electricity's initial and subsequent order delivery period requirements.

All documents under b) and c) above, shall be fully completed by the Tenderer and submitted with the bid documents. Clarification on the returnable documents may be sought with the Tenderer if necessary.

ITEM NO, DESCRIPTION, STOCK CODE AND ESTIMATED QUANTITY SCHEDULE

Item no.	Description	Stock code	Annual estimated quantity
1	Stay-anchor 2 000 mm long × 20 mm diameter with 375 mm × 375 mm × 6 mm stay-plate	1419	1 450
2	Thimble	1628	3 700
3	Guy grip dead-end fitting for 3/4,00 mm, 700 MPa staywire	960	90
4	Guy grip dead-end fitting for 7/4,00 mm, 700 MPa staywire	961	10 500
5	Staywire 3/4,00 mm, 700 MPa, 30 m coils	1718	5 coils
6	Staywire 7/4,00 mm, 700 MPa, 30 m coils	1720	900 coils
7	Porcelain stay insulator, 70 kN failing load	1009	2 300
8	Guy strain stay insulator thimble type, 70 kN failing load	1008	630
9	Stay strap	1501	90

RETURNABLE DOCUMENT 1

This document shall be completed, signed and returned with bid documents of which it forms part.

Requirements of Item 1: Stay-anchor assembly

Ref No.	Technical Details	eThekweni Electricity's Requirement	Bidder's Offer
1	Name of manufacturer		
2	Place of manufacture		
3	Manufacturer's identification reference		
4	Standard to which steel complies	SANS 50025	
5	Grade of steel	350WC or equivalent	
6	Standard to which galvanising on stay-anchor assembly complies	SANS 121	
7	Minimum thickness of zinc coating	85 µm	µm
8	Diameter of anchor-rod	20 mm	mm
9	Length of stay-anchor	2 000 mm	mm
10	Inside diameter of eye at upper end of anchor-rod	25 mm	mm
11	Method of manufacturing the eye at the top of the anchor-rod	Forged or Welded	
12	Dimension of plate welded to anchor-rod	(150 × 150 × 6) mm	× × mm
13	Typical dimension of stay-plate	(375 × 375 × 6) mm	× × mm
14	Anchor-rod not subjected to cold bending	Yes	*Yes/No
15	Minimum breaking load of stay-anchor	94 kN	kN
16	Has a formal test report been submitted in accordance with clause 3.1 i) of this specification?	Yes	*Yes/No
17	Are the markings on the stay-anchor in accordance with clause 3.1 h) of this specification?	Yes	*Yes/No

*Delete whichever is not applicable.

BIDDING COMPANY: _____

NAME: _____ SIGNED: _____

CAPACITY OF SIGNATORY: _____ DATE: YYYY - MM - DD

RETURNABLE DOCUMENT 2

This document shall be completed, signed and returned with bid documents of which it forms part.

Requirements of Item 2: Thimble

Ref No.	Technical Details	eThekwini Electricity's Requirement	Bidder's Offer
1	Name of manufacturer		
2	Place of manufacture		
3	Manufacturer's identification reference		
4	Standard to which steel complies	SANS 50025	
5	Grade of steel	350WC or equivalent	
6	Standard to which galvanising on thimble complies	SANS 121	
7	Minimum thickness of zinc coating	55 µm	µm
8	Thickness of thimble material	3 mm	mm
9	Length of thimble	70 mm	mm
10	Width of thimble	20 mm	mm
11	Inside diameter of thimble	40 mm	mm
12	Width of open end of thimble	22 mm	mm
13	Are the markings on the thimble in accordance with clause 6.2 of NRS 022:2014?	Yes	*Yes/No

*Delete whichever is not applicable.

BIDDING COMPANY: _____

NAME: _____ SIGNED: _____

CAPACITY OF SIGNATORY: _____ DATE: YYYY - MM - DD

RETURNABLE DOCUMENT 3

This document shall be completed, signed and returned with bid documents of which it forms part.

Requirements of Item 3: Guy grip dead-end fitting for 3/4,00 mm, 700 MPa staywire

Ref No.	Technical Details	eThekwini Electricity's Requirement	Bidder's Offer
1	Name of manufacturer		
2	Place of manufacture		
3	Manufacturer's identification reference		
4	Number and standard diameter of wires	3/4,00 mm	/ mm
5	Tensile grade of steel	700 MPa	MPa
6	Standard to which galvanising on wires comply	SANS 10244-2	
7	Number of re-applications on new construction the guy grip dead-end fitting is designed for?	3	
8	Does the guy grip dead-end fitting meet or exceed the test requirements of NRS 022?	Yes	*Yes/No
9	Has a formal test report been submitted with the bid documents to confirm that the fittings have met or exceeded the requirements of NRS 022?	Yes	*Yes/No
10	Are the markings on the guy grip dead-end fitting in accordance with clause 6.3 of NRS 022:2014?	Yes	*Yes/No
11	Colour code of guy grip dead-end fitting for 3/4,00,700 MPa staywire		

*Delete whichever is not applicable.

BIDDING COMPANY: _____

NAME: _____ SIGNED: _____

CAPACITY OF SIGNATORY: _____ DATE: YYYY - MM - DD

RETURNABLE DOCUMENT 4

This document shall be completed, signed and returned with bid documents of which it forms part.

Requirements of Item 4: Guy grip dead-end fitting for 7/4,00 mm, 700 MPa staywire

Ref No.	Technical Details	eThekwini Electricity's Requirement	Bidder's Offer
1	Name of manufacturer		
2	Place of manufacture		
3	Manufacturer's identification reference		
4	Number and standard diameter of wires	7/4,00 mm	/ mm
5	Tensile grade of steel	700 MPa	MPa
6	Standard to which galvanising on wires comply	SANS 10244-2	
7	Number of re-applications on new construction the guy grip dead-end fitting is designed for?	3	
8	Does the guy grip dead-end fitting meet or exceed the test requirements of NRS 022?	Yes	*Yes/No
9	Has a formal test report been submitted with the bid documents to confirm that the fittings have met or exceeded the requirements of NRS 022?	Yes	*Yes/No
10	Are the markings on the guy grip dead-end fitting in accordance with clause 6.3 of NRS 022?	Yes	*Yes/No
11	Colour code of guy grip dead-end fitting for 7/4,00,700 MPa staywire		

*Delete whichever is not applicable.

BIDDING COMPANY: _____

NAME: _____ SIGNED: _____

CAPACITY OF SIGNATORY: _____ DATE: YYYY - MM - DD

RETURNABLE DOCUMENT 5

This document shall be completed, signed and returned with bid documents of which it forms part.

Requirements of Item 5: Staywire 3/4,00 mm, 700 MPa

Ref No.	Technical Details	eThekwini Electricity's Requirement	Bidder's Offer
1	Name of manufacturer		
2	Place of manufacture		
3	Manufacturer's identification reference		
4	Standard to which staywire complies	SANS 182-5	
5	Number and standard diameter of wires	3/4,00 mm	/ mm
6	Tensile strength of staywire	700 MPa	MPa
7	Minimum breaking load of staywire	26,19 kN	kN
8	Standard to which galvanising on wires comply	SANS 10244-2	
9	Length of staywire per coil when packaging	30 m	m
10	Approximate mass of staywire per coil	9 kg	kg
11	Is each coil marked in accordance with SANS 182-5?	Yes	*Yes/No
12	Has a formal test report been submitted with the bid documents to confirm that the staywire has met or exceeded the requirements of SANS 182-5?	Yes	*Yes/No

*Delete whichever is not applicable.

BIDDING COMPANY: _____

NAME: _____ SIGNED: _____

CAPACITY OF SIGNATORY: _____ DATE: YYYY - MM - DD

RETURNABLE DOCUMENT 6

This document shall be completed, signed and returned with bid documents of which it forms part.

Requirements of Item 6: Staywire 7/4,00 mm, 700 MPa

Ref No.	Technical Details	eThekwini Electricity's Requirement	Bidder's Offer
1	Name of manufacturer		
2	Place of manufacture		
3	Manufacturer's identification reference		
4	Standard to which staywire complies	SANS 182-5	
5	Number and standard diameter of wires	7/4,00 mm	/ mm
6	Tensile strength of staywire	700 MPa	MPa
7	Minimum breaking load of staywire	61,11 kN	kN
8	Standard to which galvanising on wires comply	SANS 10244-2	
9	Length of staywire per coil	30 m	m
10	Approximate mass of staywire per coil	21 kg	kg
11	Is each coil marked in accordance with SANS 182-5?	Yes	*Yes/No
12	Has a formal test report been submitted with the bid documents to confirm that the staywire has met or exceeded the requirements of SANS 182-5?	Yes	*Yes/No

*Delete whichever is not applicable.

BIDDING COMPANY: _____

NAME: _____ SIGNED: _____

CAPACITY OF SIGNATORY: _____ DATE: YYYY - MM - DD

RETURNABLE DOCUMENT 7

This document shall be completed, signed and returned with bid documents of which it forms part.

Requirements of Item 7: Porcelain stay insulator, 70 kN failing load

Ref No.	Technical Details	eThekwini Electricity's Requirement	Bidder's Offer
1	Name of manufacturer		
2	Place of manufacture		
3	Manufacturer's identification reference		
4	Insulation material	Glazed porcelain	
5	Minimum leakage distance	76 mm	mm
6	Minimum wet <u>withstand</u> power frequency voltage rating	22 kV	kV
7	Minimum mechanical breaking load	70 kN	kN
8	Diameter of eyes in the insulator (for the attachment of the guy grip dead-end fittings)		mm
9	Overall length of insulator		mm
10	Distance between eye centres		mm
11	Colour of glazing		
12	Number of units in a container	10	
13	Are the markings on the stay insulator in accordance with clause 6.4 of NRS 022:2014?	Yes	*Yes/No
14	Has a formal test report been submitted with the bid documents to confirm that the insulator has met or exceeded the requirements of NRS 022?	Yes	*Yes/No

*Delete whichever is not applicable.

BIDDING COMPANY: _____

NAME: _____ SIGNED: _____

CAPACITY OF SIGNATORY: _____ DATE: YYYY - MM - DD

RETURNABLE DOCUMENT 8

This document shall be completed, signed and returned with bid documents of which it forms part.

Requirements of Item 8: Guy strain stay insulator, 70 kN failing load

Ref No.	Technical Details	eThekwini Electricity's Requirement	Bidder's Offer
1	Name of manufacturer		
2	Place of manufacture		
3	Manufacturer's identification reference		
4	Insulation material	Fibreglass rod that is UV light resistant	
5	Material used over fibreglass rod that gives protection against weathering and ultra-violet light		
6	End fitting material	Ductile iron	
7	Type of end fittings	Thimble-Thimble	
8	Standard to which galvanising on end fittings comply	SANS 121	
9	Minimum thickness of zinc coating	55 µm	µm
10	Method of sealing the end fitting and insulating material interface		
11	Minimum leakage distance	460 mm	mm
12	Minimum wet <u>withstand</u> power frequency voltage rating	60 kV	kV
13	Minimum mechanical breaking load	70 kN	kN
14	Diameter of thimble eyes		mm
15	Overall length of stay insulator		mm
16	Colour of fibreglass member	Light grey	
17	Number of units in a box	15	
18	Are the details of attachment of the thimble end fittings submitted?	Yes	*Yes/No
19	Are the markings on the stay insulator in accordance with clause 6.4 of NRS 022: 2014?	Yes	*Yes/No
20	Has a formal test report been submitted with the bid documents to confirm that the insulator has met or exceeded the requirements of NRS 022?	Yes	*Yes/No

*Delete whichever is not applicable.

BIDDING COMPANY: _____

NAME: _____ SIGNED: _____

CAPACITY OF SIGNATORY: _____ DATE: YYYY - MM - DD

RETURNABLE DOCUMENT 9

This document shall be completed, signed and returned with bid documents of which it forms part.

Requirements of Item 9: Stay strap

Ref No.	Technical Details	eThekwini Electricity's Requirement	Bidder's Offer
1	Name of manufacturer		
2	Place of manufacture		
3	Manufacturer's identification reference		
4	Standard to which steel complies	SANS 50025	
5	Grade of steel	350WC or equivalent	
6	Standard to which galvanising on stay strap complies	SANS 121	
7	Minimum thickness of zinc coating on stay strap	55 µm	µm
8	Width of stay strap	60 mm	mm
9	Thickness of stay strap	16 mm	mm
10	Supplied in heavy duty bags of 50 per bag	Yes	*Yes/No
11	Are the dimension of the stay strap in accordance with Figure 5 of this specification?	Yes	*Yes/No
12	Stay strap been not subjected to cold bending	Yes	*Yes/No
13	Are the markings on the stay strap in accordance with clause 6.2 of NRS 022:2014?	Yes	*Yes/No

*Delete whichever is not applicable.

BIDDING COMPANY: _____

NAME: _____ SIGNED: _____

CAPACITY OF SIGNATORY: _____ DATE: YYYY - MM - DD

DELIVERY PERIODS SCHEDULE

I/We hereby undertake to deliver the goods within the following periods from date of receipt of order. Note that delivery periods to be stated in weeks:

Item	Initial order		Subsequent orders	
	eThekwini Electricity's preferred requirements	Bidder's Offer	eThekwini Electricity's preferred requirements	Bidder's Offer
1	4 weeks	weeks	1 week	week
2	4 weeks	weeks	1 week	week
3	4 weeks	weeks	1 week	week
4	4 weeks	weeks	1 week	week
5	4 weeks	weeks	1 week	week
6	4 weeks	weeks	1 week	week
7	4 weeks	weeks	1 week	week
8	4 weeks	weeks	1 week	week
9	4 weeks	weeks	1 week	week

BIDDING COMPANY: _____

NAME: _____ SIGNED: _____

CAPACITY OF SIGNATORY: _____ DATE: _____ YYYY - MM - DD

SECTION 4: RETURNABLE TENDER DOCUMENTS

The required returnable documents are as detailed in [Section 2 \(Clause 4\)](#): “Returnable Schedules, Forms, Certificates” of the Conditions of Tender / Special Conditions of Tender.

- 1) Authority of Signatory
- 2) Tax Compliance Status PIN / Tax Clearance Certificate
- 3) Declaration of Municipal Fees
- 4) Declaration with respect to The Occupational Health and Safety Act
- 5(a) MBD 4: Declaration of Interest
- 5(b) MBD 5: Declaration for Procurement Above R10 Million
- 5(c) MBD 6.1: Preference Points Claim
- 5(d) MBD 8: Declaration of Bidder’s Past Supply Chain Management Practices
- 5(e) MBD 9: Certificate of Independent Bid Determination

The Tender Form can be found in [Section 9](#): “Official Tender Form”, and any additional schedules, forms, certificates can be found in [Section 10](#): “Annexures”.

1) AUTHORITY OF SIGNATORY

Reference is made to the Conditions of Tender: [Clause 4\(5\)\(c\)](#).

Indicate the status of the tenderer by ticking the appropriate box hereunder.

COMPANY	CLOSE CORPORATION	PARTNERSHIP	JOINT VENTURE	SOLE PROPRIETOR
Refer to Notes at the bottom of the page				

I / We, the undersigned, being the Chairperson (Company), Member(s) (Close Corporation), Partners (Partnership), Sole Owner (Sole Proprietor), Lead Partner (JV), in the company / business trading as:

.....

hereby authorise Mr/Mrs/Ms

acting in the capacity of

to sign all documents in connection with the tender for Contract No. [29023-\(5E\)](#) and any contract resulting from it on our behalf.

NAME	ADDRESS	SIGNATURE	DATE

Notes

Tenderers are to include, at the back of their tender submission document, a printout of the following documents:

- If a Company : a "Resolution of the Board" in this regard.
- If a Joint Venture : a "Power of Attorney" signed by the legally authorised signatories of all the partners to the Joint venture.

2) **TAX COMPLIANCE STATUS PIN / TAX CLEARANCE CERTIFICATE**

SARS has introduced a new Tax Compliance Status System. Tenderers can submit a Tax Compliance Status PIN (TCS PIN) instead of an original Tax Clearance Certificate. This TCS PIN can be used by third parties to certify the taxpayer’s real-time compliance status.

Separate Tax Clearance Certificates / TCS PINs are required for each entity in a Joint Venture.

The TCS PIN(s) are to be entered on the information table in **SECTION 1: GENERAL INFORMATION**.

Tenderers are to include, at the back of their tender submission document, a printout of their Tax Compliance Status PIN (TCS PIN) OR an original Tax Clearance Certificate.

Failure to include the required document will make the tender submission non-responsive.

*I, the undersigned, who warrants that they are authorised to sign on behalf of the Tenderer, confirms that the information contained in this form is within my personal knowledge and is to the best of my belief both true and correct, **and that the requested documentation has been included in the tender submission.***

NAME (Block Capitals):

Date

SIGNATURE:

3) DECLARATION OF MUNICIPAL FEES

I, the undersigned, do hereby declare that the Municipal fees of

.....
(full name of Company / Close Corporation / partnership / sole proprietary/Joint Venture)

(hereinafter referred to as the TENDERER) are, as at the date hereunder, fully paid or an Acknowledgement of Debt has been concluded with the Municipality to pay the said charges in instalments.

The following account details relate to property of the said TENDERER:

<u>Account</u>	<u>Account Number</u> : to be completed by tenderer.
Consolidated Account No.	<input type="text"/> <input type="text"/> <input type="text"/> <input type="text"/> <input type="text"/> <input type="text"/> <input type="text"/> <input type="text"/> <input type="text"/> <input type="text"/> <input type="text"/> <input type="text"/> <input type="text"/>
Electricity	<input type="text"/> <input type="text"/> <input type="text"/> <input type="text"/> <input type="text"/> <input type="text"/> <input type="text"/> <input type="text"/> <input type="text"/> <input type="text"/> <input type="text"/> <input type="text"/>
Water	<input type="text"/> <input type="text"/> <input type="text"/> <input type="text"/> <input type="text"/> <input type="text"/> <input type="text"/> <input type="text"/> <input type="text"/> <input type="text"/> <input type="text"/> <input type="text"/>
Rates	<input type="text"/> <input type="text"/> <input type="text"/> <input type="text"/> <input type="text"/> <input type="text"/> <input type="text"/> <input type="text"/> <input type="text"/> <input type="text"/> <input type="text"/> <input type="text"/>
Other	<input type="text"/> <input type="text"/> <input type="text"/> <input type="text"/> <input type="text"/> <input type="text"/> <input type="text"/> <input type="text"/> <input type="text"/> <input type="text"/> <input type="text"/> <input type="text"/>

I acknowledge that should the aforesaid Municipal charges fall into arrears, the Municipality may take such remedial action as is required, including termination of any contract, and any payments due to the Contractor by the Municipality shall be first set off against such arrears.

- Where the TENDERER'S place of business or business interests are outside the jurisdiction of eThekweni Municipality, a copy of the accounts/agreements from the relevant municipality must be attached (to the back inside cover of this document).
- Where the tenderer's Municipal Accounts are part of their lease agreement, then a copy of the agreement, or official letter to that effect is to be attached (to the back inside cover of this document).

Tenderers are to include, at the back of their tender submission document, a printout of the above account's and or agreements signed with the municipality.

Failure to include the required document will make the tender submission non-responsive.

NAME (Block Capitals):

Date

SIGNATURE:

.....
.....

4) DECLARATION WITH RESPECT TO THE OCCUPATIONAL HEALTH AND SAFETY ACT

Definitions

The Act: The Occupational Health and Safety Act No 85 of 1993 (as amended by the Occupational Health and Safety Amendment Act No 181 of 1993), and any associated / applicable Regulations.

Declaration by Tenderer

- 1. I, the undersigned, hereby declare and confirm that I am fully conversant with the Act.
- 2. I hereby declare that my company has the competence and the necessary resources to safely carry out the work / supply / services under this contract in compliance with the Act, and the Employer's / Purchaser's / Client's Health and Safety Specifications.
- 3. I hereby undertake, if my tender is accepted, to provide on request a suitable and sufficiently documented Health and Safety Plan which plan shall be subject to approval by the Employer / Purchaser / Client.
- 4. I hereby confirm that adequate provision has been made in my tendered rates to cover the cost of all resources, actions, training and all health and safety measures envisaged in the Act, and that I will be liable for any penalties that may be applied by the Employer / Purchaser / Client for failure to comply with the provisions of the Act.
- 5. I agree that my failure to complete and execute this declaration to the satisfaction of the Employer / Purchaser / Client will mean that I am unable to comply with the requirements of the Act and accept that my tender will be prejudiced and may be rejected at the discretion of the Employer / Purchaser / Client.

NAME (Block Capitals):

Date

SIGNATURE:

5(a) MBD 4: DECLARATION OF INTEREST

NOTES
 MSCM Regulations: "in the service of the state" means to be:
 (a) a member of:
 (i) any municipal council.
 (ii) any provincial legislature.
 (iii) the national Assembly or the national Council of provinces.
 (b) a member of the board of directors of any municipal enterprise.
 (c) an official of any municipality or municipal enterprise.
 (d) an employee of any national or provincial department, national or provincial public enterprise or constitutional institution within the meaning of the Public Finance Management Act, 1999 (Act No.1 of 1999).
 (e) a member of the accounting authority of any national or provincial public enterprise.
 (f) an employee of Parliament or a provincial legislature.
 "Shareholder" means a person who owns shares in the company and is actively involved in the management of the company or business and exercises control over the company.

- 1 No bid will be accepted from persons **in the service of the state**.
- 2 Any person, having a kinship with persons **in the service of the state**, including a blood relationship, may make an offer or offers in terms of this invitation to bid. In view of possible allegations of favouritism, should the resulting bid, or part thereof, be awarded to persons connected with or related to **persons in service of the state**, it is required that the bidder or their authorised representative declare their position in relation to the evaluating/adjudicating authority and/or take an oath declaring his/her interest.
- 3 In order to give effect to the above, the following questionnaire must be completed and submitted with the bid.

3.1 Name of enterprise	
Name of enterprise's representative	
3.2 ID Number of enterprise's representative	
3.3 Position enterprise's representative occupies in the enterprise	
3.4 Company Registration number	
3.5 Tax Reference number	
3.6 VAT registration number	

3.7 The names of all directors / trustees / shareholders / members / sole proprietors / partners in partnerships, their individual identity numbers and state employee numbers must be indicated in paragraph 4 below. In the case of a joint venture, information in respect of each partnering enterprise must be completed and submitted.

3.8 Are you presently in the service of the state? If yes, furnish particulars:	Circle Applicable	
	YES	NO

.....

3.9 Have you been in the service of the state for the past twelve months? If yes, furnish particulars:	YES	NO
---	-----	----

.....

3.10 Do you have any relationship (family, friend, other) with persons in the service of the state and who may be involved with the evaluation and or adjudication of this bid? YES NO
 If yes, furnish particulars:

3.11 Are you, aware of any relationship (family, friend, other) between any other bidder and any persons in the service of the state who may be involved with the evaluation and or adjudication of this bid? YES NO
 If yes, furnish particulars:

3.12 Are any of the company's directors, trustees, managers, principle shareholders or stakeholders in service of the state? YES NO
 If yes, furnish particulars:

3.13 Are any spouse, child or parent of the company's directors, trustees, managers, principle shareholders or stakeholders in service of the state? YES NO
 If yes, furnish particulars:

3.14 Do you or any of the directors, trustees, managers, principle shareholders, or stakeholders of this company have any interest in any other related companies or business whether or not they are bidding for this contract? YES NO
 If yes, furnish particulars:

4 The names of all directors / trustees / shareholders / members / sole proprietors / partners in partnerships, their individual identity numbers and state employee numbers must be indicated below. In the case of a joint venture, information in respect of each partnering enterprise must be completed and submitted

Full Name	Identity No.	State Employee No.	Personal income tax No.
Use additional pages if necessary			

I, the undersigned, who warrants that they are authorised to sign on behalf of the Tenderer, confirms that the information contained in this form is within my personal knowledge and is to the best of my belief both true and correct.

NAME (Block Capitals): _____ **Date** _____
SIGNATURE: _____

5(b) **MBD 5: DECLARATION FOR PROCUREMENT ABOVE R10 MILLION**
(ALL APPLICABLE TAXES INCLUDED)

For all procurement expected to exceed R10 million (all applicable taxes included), bidders must complete the following questionnaire.

	Circle Applicable	
1.0 Are you by law required to prepare annual financial statements for auditing?	YES	NO
1.1 If YES, submit audited annual financial statements for the past three years or since the date of establishment if established during the past three years.		
2.0 Do you have any outstanding undisputed commitments for municipal services towards any municipality for more than three months or any other service provider in respect of which payment is overdue for more than 30 days?	YES	NO
2.1 If NO, this serves to certify that the bidder has no undisputed commitments for municipal services towards any municipality for more than three months or other service provider in respect of which payment is overdue for more than 30 days.		
2.2 If YES, provide particulars.		
3.0 Has any contract been awarded to you by an organ of state during the past five years, including particulars of any material non-compliance or dispute concerning the execution of such contract?	YES	NO
3.1 If YES, provide particulars.		
4.0 Will any portion of goods or services be sourced from outside the Republic, and, if so, what portion and whether any portion of payment from the municipality / municipal entity is expected to be transferred out of the Republic?	YES	NO
4.1 If YES, provide particulars.		

If required by 1.1 above, tenderers are to include, at the back of their tender submission document, a printout of their audited annual financial statements.

I, the undersigned, who warrants that they are authorised to sign on behalf of the Tenderer, confirms that the information contained in this form is within my personal knowledge and is to the best of my belief both true and correct, and, if required, that the requested documentation has been included in the tender submission.

NAME (Block Capitals): _____ **Date** _____
SIGNATURE: _____

5(c) **MBD 6.1: PREFERENCE POINTS CLAIM**
In terms of THE PREFERENTIAL PROCUREMENT REGULATIONS (2022)

This preference form must form part of all tenders invited. It contains general information and serves as a claim form for preference points for specific goals.

NB: BEFORE COMPLETING THIS FORM, TENDERERS MUST STUDY THE GENERAL CONDITIONS, DEFINITIONS AND DIRECTIVES APPLICABLE IN RESPECT OF THE TENDER AND PREFERENTIAL PROCUREMENT REGULATIONS, 2022

1.0 GENERAL CONDITIONS

- 1.1 The following preference point systems are applicable to invitations to tender:
- the 80/20 system for requirements with a Rand value of up to R50 000 000 (all applicable taxes included).
- 1.2 The applicable preference point system for this tender is the **80/20 preference point system**.
- 1.3 Preference Points for this tender shall be awarded for:
- **Price and Specific Goals:** 80 (price) and 20 (specific goals), in terms of 1.2 above.
 - The total Preference Points, for Price and Specific Goals, is 100.
- 1.4 Failure on the part of the tenderer to submit the required proof or documentation, in terms of the requirements in the (Special) Conditions of Tender for claiming **Specific Goal** preference points, will be interpreted that preference points for **Specific Goals** are not claimed.
- 1.5 The Municipality reserves the right to require of a tenderer, either before a tender is adjudicated or at any time subsequently, to substantiate any claim in regard of preferences, in any manner required by the Municipality.

2.0 DEFINITIONS

- 2.1 “**tender**” means a written offer in the form determined by an organ of state in response to an invitation to provide goods or services through price quotations, competitive tendering process or any other method envisaged in legislation.
- 2.2 “**price**” means an amount of money tendered for goods or services, and includes all applicable taxes less all unconditional discounts.
- 2.3 “**rand value**” means the total estimated value of a contract in Rand, calculated at the time of bid invitation, and includes all applicable taxes.
- 2.4 “**tender for income-generating contracts**” means a written offer in the form determined by Municipality in response to an invitation for the origination of income-generating contracts through any method envisaged in legislation that will result in a legal agreement between the Municipality and a third party that produces revenue for the Municipality, and includes, but is not limited to, leasing and disposal of assets and concession contracts, excluding direct sales and disposal of assets through public auctions.
- 2.5 “**the Act**” means the Preferential Procurement Policy Framework Act, 2000 (Act No. 5 of 2000).

3.0 FORMULA FOR CALCULATION OF PREFERENCE PRICE POINTS

3.1 PROCUREMENT OF GOODS AND SERVICES

PRICE POINTS: A maximum of 80 or 90 points is allocated for price on the following basis:

80 / 20 Points System

OR

90 / 10 Points System

$$P_s = 80 \left(1 - \frac{P_t - P_{min}}{P_{min}} \right)$$

$$P_s = 90 \left(1 - \frac{P_t - P_{min}}{P_{min}} \right)$$

Where:

P_s = Points scored for price of tender under consideration

P_t = Price of tender under consideration

P_{min} = Price of lowest acceptable tender

4.0 POINTS AWARDED FOR SPECIFIC GOALS

- 4.1 In terms of Regulation 4(2); 5(2); 6(2) and 7(2) of the Preferential Procurement Regulations, preference points must be awarded for specific goals stated in the tender. For the purposes of this tender the tenderer will be allocated points based on the **points claimed** for the goal(s) stated in **Table 1** below, as supported by proof/ documentation stated in the **Conditions of Tender**:
- 4.2 4.3 In cases where the municipality intends to use Regulation 3(2) of the Regulations, which states that if it is unclear whether the 80/20 or 90/10 preference point system applies, the municipality must, in the tender documents, stipulate in the case of:
- (a) an invitation for tender for income-generating contracts, that either the 80/20 or 90/10 preference point system will apply and that the highest acceptable tender will be used to determine the applicable preference point system, or
 - (b) any other invitation for tender, that either the 80/20 or 90/10 preference point system will apply and that the lowest acceptable tender will be used to determine the applicable preference point system,
- then the municipality must indicate the points allocated for specific goals for both the 90/10 and 80/20 preference point system.

TABLE 1 - Specific Goals for the tender and points claimed are indicated per the table below. Tenderers are to indicate their points claim for each of the Specific Goals.				
The Specific Goals to be allocated points in terms of this tender	GOAL WEIGHTING	Points ALLOCATED (80/20 system)	Points CLAIMED (80/20 system)	Proof of Claim from *CSD Registration Report
				Report Date: 2023 – MM – YY
				Supplier Number:
Ownership Goal: Race: Black (100 %)	40 %	8		B-BBEE Information Black Ownership %
RDP Goal: The promotion of South African owned enterprises.	40 %	8		Supplier Address Information:
RDP Goal: The promotion of export-oriented production to create jobs.	20 %	4		Industry Classification:
TOTAL	100 %	20		*No later than one month prior to bid closing date
RDP Goal: The Creation of new jobs to address black youth unemployment				
RDP Goal: The promotion of enterprises located in a specific municipal area.				
RDP Goal: Social upliftment of communities				
RDP Goal: The promotion of SMMEs owned by PPG (contracts >R5m)				
Should the municipality apply a combination of Specific Goals, the points for the individual goals will be weighted according to the Goal Weightings specified in the Tender Data to arrive at the final points for Preferential Points for Specific Goals .				
I, the undersigned, who warrants that they are authorised to sign on behalf of the Tenderer, certify that the points claimed, based on the specific goals as specified in the tender, qualifies the tendering entity for the preference(s) shown.				
I acknowledge that:				
1) The information furnished is true and correct. 2) The preference points claimed are in accordance with the General Conditions as indicated in paragraph 1 of this form. 3) In the event of a contract being awarded as a result of points claimed as shown in paragraphs 1.4 and 4.2, the contractor may be required to furnish documentary proof to the satisfaction of the organ of state that the claims are correct. 4) If the specific goals have been claimed or obtained on a fraudulent basis, or any of the conditions of contract have not been fulfilled, the organ of state may, in addition to any other remedy it may have: <ol style="list-style-type: none"> disqualify the person from the tendering process. recover costs, losses or damages it has incurred or suffered as a result of that person's conduct. cancel the contract and claim any damages which it has suffered as a result of having to make less favourable arrangements due to such cancellation. recommend that the tenderer or contractor, its shareholders and directors, or only the shareholders and directors who acted on a fraudulent basis, be restricted from obtaining business from any organ of state for a period not exceeding 10 years, after the <i>audi alteram partem</i> (hear the other side) rule has been applied; and forward the matter for criminal prosecution, if deemed necessary. 				
NAME (Block Capitals):		Date		
SIGNATURE:				

5(d) MBD 8: DECLARATION OF BIDDER'S PAST SUPPLY CHAIN MANAGEMENT PRACTICES

- 1.0 This Municipal Bidding Document must form part of all bids invited.
- 2.0 It serves as a declaration to be used by municipalities and municipal entities in ensuring that when goods and services are being procured, all reasonable steps are taken to combat the abuse of the supply chain management system.
- 3.0 The bid of any bidder may be rejected if that bidder, or any of its directors have:
 - a) abused the municipal entity's supply chain management system or committed any improper conduct in relation to such system.
 - b) been convicted for fraud or corruption during the past five years.
 - c) wilfully neglected, reneged on or failed to comply with any government, municipal or other public sector contract during the past five years.
 - d) been listed in the Register for Tender Defaulters in terms of section 29 of the Prevention and Combating of Corrupt Activities Act (No 12 of 2004).
- 4.0 In order to give effect to the above, the following questions must be completed and submitted with the bid.

4.1 Is the bidder or any of its directors listed on the National Treasury's Database of Restricted Suppliers as companies or persons prohibited from doing business with the public sector?

(Companies or persons who are listed on this Database were informed in writing of this restriction by the Accounting Officer / Authority of the institution that imposed the restriction after the audi alteram partem rule was applied.)

The Database of Restricted Suppliers now resides on the National Treasury's website (www.treasury.gov.za) and can be accessed by clicking on its link at the bottom of the home page.

4.1.1 If YES, provide particulars.

.....

Circle Applicable	
YES	NO

4.2 Is the bidder or any of its directors listed on the Register for Tender Defaulters in terms of section 29 of the Prevention and Combating of Corrupt Activities Act (No 12 of 2004)?

The Register for Tender Defaulters can be accessed on the National Treasury's website (www.treasury.gov.za) by clicking on its link at the bottom of the home page.

4.2.1 If YES, provide particulars.

.....

YES	NO
-----	----

4.3 Was the bidder or any of its directors convicted by a court of law (including a court of law outside the Republic of South Africa) for fraud or corruption during the past five years?

4.3.1 If YES, provide particulars.

.....

YES	NO
-----	----

4.4 Does the bidder or any of its directors owe any municipal rates and taxes or municipal charges to the municipality / municipal entity, or to any other municipality / municipal entity, that is in arrears for more than three months?

YES	NO
-----	----

4.4.1 If YES, provide particulars.

.....

.....

4.5 Was any contract between the bidder and the municipality / municipal entity or any other organ of state terminated during the past five years on account of failure to perform on or comply with the contract?

YES	NO
-----	----

4.5.1 If YES, provide particulars.

.....

.....

I, the undersigned, who warrants that they are authorised to sign on behalf of the Tenderer, confirms that the information contained in this form is within my personal knowledge and is to the best of my belief both true and correct.

I accept that, in addition to cancellation of a contract, action may be taken against me should this declaration prove to be false.

NAME (Block Capitals):

Date

SIGNATURE:

5(e) MBD 9: CERTIFICATE OF INDEPENDENT BID DETERMINATION**NOTES**

- ¹ Includes price quotations, advertised competitive bids, limited bids and proposals.
- ² Bid rigging (or collusive bidding) occurs when businesses, that would otherwise be expected to compete, secretly conspire to raise prices or lower the quality of goods and / or services for purchasers who wish to acquire goods and / or services through a bidding process. Bid rigging is, therefore, an agreement between competitors not to compete.
- ³ Joint venture or Consortium means an association of persons for the purpose of combining their expertise, property, capital, efforts, skill and knowledge in an activity for the execution of a contract.

- 1.0 This Municipal Bidding Document (MBD) must form part of all **bids**¹ invited.
- 2.0 Section 4 (1) (b) (iii) of the Competition Act No. 89 of 1998, as amended, prohibits an agreement between, or concerted practice by, firms, or a decision by an association of firms, if it is between parties in a horizontal relationship and if it involves collusive bidding (or **bid rigging**).² Collusive bidding is a *pe se* prohibition meaning that it cannot be justified under any grounds.
- 3.0 Municipal Supply Regulation 38 (1) prescribes that a supply chain management policy must provide measures for the combating of abuse of the supply chain management system, and must enable the accounting officer, among others, to:
- a. take all reasonable steps to prevent such abuse;
 - b. reject the bid of any bidder if that bidder or any of its directors has abused the supply chain management system of the municipality or municipal entity or has committed any improper conduct in relation to such system; and
 - c. cancel a contract awarded to a person if the person committed any corrupt or fraudulent act during the bidding process or the execution of the contract.
- 4.0 This MBD serves as a certificate of declaration that would be used by institutions to ensure that, when bids are considered, reasonable steps are taken to prevent any form of **bid rigging**.
- 5.0 In order to give effect to the above, the attached Certificate of Bid Determination (MBD 9) must be completed and submitted with the bid.

CERTIFICATE OF INDEPENDENT BID DETERMINATION

I, the undersigned, in submitting the accompanying bid:

(Bid Number and Description)

in response to the invitation for the bid made by:

(Name of Municipality / Municipal Entity)

do hereby make the following statements that I certify to be true and complete in every respect.

I certify, on behalf of:

(Name of Bidder)

that:

1. I have read and I understand the contents of this Certificate.
2. I understand that the accompanying bid will be disqualified if this Certificate is found not to be true and complete in every respect.
3. I am authorized by the bidder to sign this Certificate, and to submit the accompanying bid, on behalf of the bidder;
4. Each person whose signature appears on the accompanying bid has been authorized by the bidder to determine the terms of, and to sign, the bid, on behalf of the bidder;
5. For the purposes of this Certificate and the accompanying bid, I understand that the word "competitor" shall include any individual or organization, other than the bidder, whether or not affiliated with the bidder, who:
 - (a) has been requested to submit a bid in response to this bid invitation.
 - (b) could potentially submit a bid in response to this bid invitation, based on their qualifications, abilities or experience.
 - (c) provides the same goods and services as the bidder and/or is in the same line of business as the bidder.
6. The bidder has arrived at the accompanying bid independently from, and without consultation, communication, agreement, or arrangement with any competitor. However, communication between partners in a joint venture or consortium³ will not be construed as collusive bidding.

- 7. In particular, without limiting the generality of paragraphs 6 above, there has been no consultation, communication, agreement or arrangement with any competitor regarding:
 - (a) prices.
 - (b) geographical area where product or service will be rendered (market allocation).
 - (c) methods, factors or formulas used to calculate prices.
 - (d) the intention or decision to submit or not to submit, a bid.
 - (e) the submission of a bid which does not meet the specifications and conditions of the bid.
 - (f) bidding with the intention not to win the bid.

- 8. In addition, there have been no consultations, communications, agreements, or arrangements with any competitor regarding the quality, quantity, specifications and conditions or delivery particulars of the products or services to which this bid invitation relates.

- 9. The terms of the accompanying bid have not been, and will not be, disclosed by the bidder, directly or indirectly, to any competitor, prior to the date and time of the official bid opening or of the awarding of the contract.

- 10. I am aware that, in addition and without prejudice to any other remedy provided to combat any restrictive practices related to bids and contracts, bids that are suspicious will be reported to the Competition Commission for investigation and possible imposition of administrative penalties in terms of section 59 of the Competition Act No 89 of 1998 and or may be reported to the National Prosecuting Authority (NPA) for criminal investigation and or may be restricted from conducting business with the public sector for a period not exceeding ten (10) years in terms of the Prevention and Combating of Corrupt Activities Act No 12 of 2004 or any other applicable legislation.

NAME (Block Capitals): _____ **Date** _____

SIGNATURE: _____

SECTION 5: CONDITIONS OF CONTRACT

GOVERNMENT PROCUREMENT: CONDITIONS OF CONTRACT (July 2010)

The **Conditions of Contract** are the **General Conditions of Contract** as published by the National Treasury titled "Government Procurement: General Conditions of Contract (July 2010), as amended by National Treasury Circular 52 dated 30 July 2010, hereinafter referred to as **GCC**.

THE NATIONAL TREASURY

Republic of South Africa



**GOVERNMENT PROCUREMENT:
GENERAL CONDITIONS OF CONTRACT**

July 2010

TABLE OF CLAUSES

1.	Definitions	43
2.	Application.....	43
3.	General	43
4.	Standards.....	44
5.	Use of contract documents and information inspection.....	44
6.	Patent Rights	44
7.	Performance security.....	44
8.	Inspections, tests and analyses.....	44
9.	Packing.....	44
10.	Delivery and documents	44
11.	Insurance	44
12.	Transportation	44
13.	Incidental Services	45
14.	Spare parts.....	45
15.	Warranty.....	45
16.	Payment.....	45
17.	Prices	45
18.	Variation orders.....	45
19.	Assignment	45
20.	Subcontracts	45
21.	Delays in the supplier's performance	45
22.	Penalties	46
23.	Termination for default	46
24.	Anti-dumping and countervailing duties and rights.....	46
25.	Force Majeure	46
26.	Termination for insolvency	46
27.	Settlement of Disputes	47
28.	Limitation of Liability	47
29.	Governing language	47
30.	Applicable law.....	47
31.	Notices.....	47
32.	Taxes and duties	47
33.	Transfer of contracts.....	47
34.	Amendments of contracts	47
35.	Prohibition of restrictive practices.....	47

- 1. Definitions**
The following terms shall be interpreted as indicated:
- 1.1 "Closing time" means the date and hour specified in the bidding documents for the receipt of bids.
- 1.2 "Contract" means the written agreement entered into between the purchaser and the supplier, as recorded in the contract form signed by the parties, including all attachments and appendices thereto and all documents incorporated by reference therein.
- 1.3 "Contract price" means the price payable to the supplier under the contract for the full and proper performance of his contractual obligations.
- 1.4 "Corrupt practice" means the offering, giving, receiving, or soliciting of anything of value to influence the action of a public official in the procurement process or in contract execution.
- 1.5 "Countervailing duties" are imposed in cases where an enterprise abroad is subsidized by its government and encouraged to market its products internationally.
- 1.6 "Country of origin" means the place where the goods were mined, grown or produced or from which the services are supplied. Goods are produced when, through manufacturing, processing or substantial and major assembly of components, a commercially recognized new product results that is substantially different in basic characteristics or in purpose or utility from its components.
- 1.7 "Day" means calendar day.
- 1.8 "Delivery" means delivery in compliance of the conditions of the contract or order.
- 1.9 "Delivery ex stock" means immediate delivery directly from stock actually on hand.
- 1.10 "Delivery into consignees store or to his site" means delivered and unloaded in the specified store or depot or on the specified site in compliance with the conditions of the contract or order, the supplier bearing all risks and charges involved until the goods are so delivered and a valid receipt is obtained.
- 1.11 "Dumping" occurs when a private enterprise abroad market its goods on own initiative in the RSA at lower prices than that of the country of origin and which have the potential to harm the local industries in the RSA.
- 1.12 "Force majeure" means an event beyond the control of the supplier and not involving the supplier's fault or negligence and not foreseeable. Such events may include, but is not restricted to, acts of the purchaser in its sovereign capacity, wars or revolutions, fires, floods, epidemics, quarantine restrictions and freight embargoes.
- 1.13 "Fraudulent practice" means a misrepresentation of facts in order to influence a procurement process or the execution of a contract to the detriment of any bidder, and includes collusive practice among bidders (prior to or after bid submission) designed to establish bid prices at artificial non-competitive levels and to deprive the bidder of the benefits of free and open competition.
- 1.14 "GCC" means the General Conditions of Contract.
- 1.15 "Goods" means all of the equipment, machinery, and/or other materials that the supplier is required to supply to the purchaser under the contract.
- 1.16 "Imported content" means that portion of the bidding price represented by the cost of components, parts or materials which have been or are still to be imported (whether by the supplier or his subcontractors) and which costs are inclusive of the costs abroad, plus freight and other direct importation costs such as landing costs, dock dues, import duty, sales duty or other similar tax or duty at the South African place of entry as well as transportation and handling charges to the factory in the Republic where the goods covered by the bid will be manufactured.
- 1.17 "Local content" means that portion of the bidding price, which is not included in the imported content provided that local manufacture does take place.
- 1.18 "Manufacture" means the production of products in a factory using labour, materials, components and machinery and includes other related value-adding activities.
- 1.19 "Order" means an official written order issued for the supply of goods or works or the rendering of a service.
- 1.20 "Project site," where applicable, means the place indicated in bidding documents.
- 1.21 "Purchaser" means the organization purchasing the goods.
- 1.22 "Republic" means the Republic of South Africa.
- 1.23 "SCC" means the Special Conditions of Contract.
- 1.24 "Services" means those functional services ancillary to the supply of the goods, such as transportation and any other incidental services, such as installation, commissioning, provision of technical assistance, training, catering, gardening, security, maintenance and other such obligations of the supplier covered under the contract.
- 1.25 "Supplier" means the successful bidder who is awarded the contract to maintain and administer the required and specified service(s) to the State.
- 1.26 "Tort" means in breach of contract.
- 1.27 "Turnkey" means a procurement process where one service provider assumes total responsibility for all aspects of the project and delivers the full end product / service required by the contract.
- 1.28 "Written" or "in writing" means hand-written in ink or any form of electronic or mechanical writing.
- 2. Application**
- 2.1 These general conditions are applicable to all bids, contracts and orders including bids for functional and professional services (excluding professional services related to the building and construction industry), sales, hiring, letting and the granting or acquiring of rights, but excluding immovable property, unless otherwise indicated in the bidding documents.
- 2.2 Where applicable, special conditions of contract are also laid down to cover specific goods, services or works.
- 2.3 Where such special conditions of contract are in conflict with these general conditions, the special conditions shall apply.
- 3. General**
- 3.1 Unless otherwise indicated in the bidding documents, the purchaser shall not be liable for any expense incurred in the preparation and submission of a bid. Where applicable a non-refundable fee for documents may be charged.
- 3.2 Invitations to bid are usually published in locally distributed news media and on the municipality/municipal entity website.

- 4. Standards**
- 4.1 The goods supplied shall conform to the standards mentioned in the bidding documents and specifications.
- 5. Use of contract documents and information inspection**
- 5.1 The supplier shall not, without the purchaser's prior written consent, disclose the contract, or any provision thereof, or any specification, plan, drawing, pattern, sample, or information furnished by or on behalf of the purchaser in connection therewith, to any person other than a person employed by the supplier in the performance of the contract. Disclosure to any such employed person shall be made in confidence and shall extend only so far as may be necessary for purposes of such performance.
- 5.2 The supplier shall not, without the purchaser's prior written consent, make use of any document or information mentioned in GCC clause 5.1 except for purposes of performing the contract.
- 5.3 Any document, other than the contract itself mentioned in GCC clause 5.1 shall remain the property of the purchaser and shall be returned (all copies) to the purchaser on completion of the supplier's performance under the contract if so required by the purchaser.
- 5.4 The supplier shall permit the purchaser to inspect the supplier's records relating to the performance of the supplier and to have them audited by auditors appointed by the purchaser, if so required by the purchaser.
- 6. Patent Rights**
- 6.1 The supplier shall indemnify the purchaser against all third-party claims of infringement of patent, trademark, or industrial design rights arising from use of the goods or any part thereof by the purchaser.
- 6.2 When a supplier developed documentation / projects for the municipality / municipal entity, the intellectual, copy and patent rights or ownership of such documents or projects will vest in the municipality / municipal entity.
- 7. Performance security**
- 7.1 Within thirty (30) days of receipt of the notification of contract award, the successful bidder shall furnish to the purchaser the performance security of the **amount specified in SCC**.
- 7.2 The proceeds of the performance security shall be payable to the purchaser as compensation for any loss resulting from the supplier's failure to complete his obligations under the contract.
- 7.3 The performance security shall be denominated in the currency of the contract or in a freely convertible currency acceptable to the purchaser and shall be in one of the following forms:
- (a) a bank guarantee or an irrevocable letter of credit issued by a reputable bank located in the purchaser's country or abroad, acceptable to the purchaser, in the form provided in the bidding documents or another form acceptable to the purchaser; or
- (b) a cashier's or certified cheque.
- 7.4 The performance security will be discharged by the purchaser and returned to the supplier not later than thirty (30) days following the date of completion of the supplier's performance obligations under the contract, including any warranty obligations, **unless otherwise specified**.
- 8. Inspections, tests and analyses**
- 8.1 All pre-bidding testing will be for the account of the bidder.
- 8.2 If it is a bid condition that goods to be produced or services to be rendered should at any stage be subject to inspections, tests and analyses, the bidder or contractor's premises shall be open, at all reasonable hours, for inspection by a representative of the purchaser or organization acting on behalf of the purchaser.
- 8.3 If there are no inspection requirements indicated in the bidding documents and no mention is made in the contract, but during the contract period it is decided that inspections shall be carried out, the purchaser shall itself make the necessary arrangements, including payment arrangements with the testing authority concerned.
- 8.4 If the inspections, tests and analyses referred to in clauses 8.2 and 8.3 show the goods to be in accordance with the contract requirements, the cost of the inspections, tests and analyses shall be defrayed by the purchaser.
- 8.5 Where the goods or services referred to in clauses 8.2 and 8.3 do not comply with the contract requirements, irrespective of whether such goods or services are accepted or not, the cost in connection with these inspections, tests or analyses shall be defrayed by the supplier.
- 8.6 Goods and services which are referred to in clauses 8.2 and 8.3 and which do not comply with the contract requirements may be rejected.
- 8.7 Any contract goods may on or after delivery be inspected, tested or analysed and may be rejected if found not to comply with the requirements of the contract. Such rejected goods shall be held at the cost and risk of the supplier who shall, when called upon, remove them immediately at his own cost and forthwith substitute them with goods, which do comply with the requirements of the contract. Failing such removal the rejected goods shall be returned at the suppliers cost and risk. Should the supplier fail to provide the substitute goods forthwith, the purchaser may, without giving the supplier further opportunity to substitute the rejected goods, purchase such goods as may be necessary at the expense of the supplier.
- 8.8 The provisions of clauses 8.4 to 8.7 shall not prejudice the right of the purchaser to cancel the contract on account of a breach of the conditions thereof, or to act in terms of Clause 22 of GCC.
- 9. Packing**
- 9.1 The supplier shall provide such packing of the goods as is required to prevent their damage or deterioration during transit to their final destination, as indicated in the contract. The packing shall be sufficient to withstand, without limitation, rough handling during transit and exposure to extreme temperatures, salt and precipitation during transit, and open storage. Packing, case size weights shall take into consideration, where appropriate, the remoteness of the goods' final destination and the absence of heavy handling facilities at all points in transit.
- 9.2 The packing, marking, and documentation within and outside the packages shall comply strictly with such special requirements as shall be expressly provided for in the contract, **including additional requirements**, if any, and in any subsequent instructions ordered by the purchaser.
- 10. Delivery and documents**
- 10.1 Delivery of the goods and arrangements for shipping and clearance obligations, shall be made by the supplier in accordance with the terms **specified in the contract**.
- 11. Insurance**
- 11.1 The goods supplied under the contract shall be fully insured in a freely convertible currency against loss or damage incidental to manufacture or acquisition, transportation, storage and delivery **in the manner specified**.
- 12. Transportation**
- 12.1 Should a price other than an all-inclusive delivered price be required, **this shall be specified**.

13. Incidental Services

13.1 The supplier may be required to provide any or all of the following services, including additional services, if any:

- (a) performance or supervision of on-site assembly and/or commissioning of the supplied goods;
- (b) furnishing of tools required for assembly and/or maintenance of the supplied goods;
- (c) furnishing of a detailed operations and maintenance manual for each appropriate unit of the supplied goods;
- (d) performance or supervision or maintenance and/or repair of the supplied goods, for a period of time agreed by the parties, provided that this service shall not relieve the supplier of any warranty obligations under this contract; and
- (e) training of the purchaser's personnel, at the supplier's plant and/or on-site, in assembly, start-up, operation, maintenance, and/or repair of the supplied goods.

13.2 Prices charged by the supplier for incidental services, if not included in the contract price for the goods, shall be agreed upon in advance by the parties and shall not exceed the prevailing rates charged to other parties by the supplier for similar services.

14. Spare parts

14.1 As specified, the supplier may be required to provide any or all of the following materials, notifications, and information pertaining to spare parts manufactured or distributed by the supplier:

- (a) such spare parts as the purchaser may elect to purchase from the supplier, provided that this election shall not relieve the supplier of any warranty obligations under the contract; and;
- (b) in the event of termination of production of the spare parts:
 - (i) advance notification to the purchaser of the pending termination, in sufficient time to permit the purchaser to procure needed requirements; and
 - (ii) following such termination, furnishing at no cost to the purchaser, the blueprints, drawings, and specifications of the spare parts, if requested.

15. Warranty

15.1 The supplier warrants that the goods supplied under the contract are new, unused, of the most recent or current models, and that they incorporate all recent improvements in design and materials unless provided otherwise in the contract. The supplier further warrants that all goods supplied under this contract shall have no defect, arising from design, materials, or workmanship (except when the design and/or material is required by the purchaser's specifications) or from any act or omission of the supplier, that may develop under normal use of the supplied goods in the conditions prevailing in the country of final destination.

15.2 This warranty shall remain valid for twelve (12) months after the goods, or any portion thereof as the case may be, have been delivered to and accepted at the final destination indicated in the contract, or for eighteen (18) months after the date of shipment from the port or place of loading in the source country, whichever period concludes earlier, unless specified otherwise.

15.3 The purchaser shall promptly notify the supplier in writing of any claims arising under this warranty.

15.4 Upon receipt of such notice, the supplier shall, within the period specified and with all reasonable speed, repair or replace the defective goods or parts thereof, without costs to the purchaser.

15.5 If the supplier, having been notified, fails to remedy the defect(s) within the period specified, the purchaser may proceed to take such remedial action as may be necessary, at the supplier's risk and expense and without prejudice to any other rights which the purchaser may have against the supplier under the contract.

16. Payment

16.1 The method and conditions of payment to be made to the supplier under this contract shall be specified.

16.2 The supplier shall furnish the purchaser with an invoice accompanied by a copy of the delivery note and upon fulfilment of other obligations stipulated in the contract.

16.3 Payments shall be made promptly by the purchaser, but in no case later than thirty (30) days after submission of an invoice or claim by the supplier.

16.4 Payment will be made in Rand unless otherwise stipulated.

17. Prices

17.1 Prices charged by the supplier for goods delivered and services performed under the contract shall not vary from the prices quoted by the supplier in his bid, with the exception of any price adjustments authorized or in the purchaser's request for bid validity extension, as the case may be.

18. Variation orders

18.1 In cases where the estimated value of the envisaged changes in purchase does not vary more than 15% of the total value of the original contract, the contractor may be instructed to deliver the goods or render the services as such. In cases of measurable quantities, the contractor may be approached to reduce the unit price, and such offers may be accepted provided that there is no escalation in price.

19. Assignment

19.1 The supplier shall not assign, in whole or in part, its obligations to perform under the contract, except with the purchaser's prior written consent.

20. Subcontracts

20.1 The supplier shall notify the purchaser in writing of all subcontracts awarded under this contracts if not already specified in the bid. Such notification, in the original bid or later, shall not relieve the supplier from any liability or obligation under the contract.

21. Delays in the supplier's performance

21.1 Delivery of the goods and performance of services shall be made by the supplier in accordance with the time schedule prescribed by the purchaser in the contract.

21.2 If at any time during performance of the contract, the supplier or its subcontractor(s) should encounter conditions impeding timely delivery of the goods and performance of services, the supplier shall promptly notify the purchaser in writing of the fact of the delay, its likely duration and its cause(s). As soon as practicable after receipt of the supplier's notice, the purchaser shall evaluate the situation and may at his discretion extend the supplier's time for performance, with or without the imposition of penalties, in which case the extension shall be ratified by the parties by amendment of contract.

21.3 The right is reserved to procure outside of the contract small quantities or to have minor essential services executed if an emergency arises, the supplier's point of supply is not situated at or near the place where the goods are required, or the supplier's services are not readily available.

- 21.4 Except as provided under GCC Clause 25, a delay by the supplier in the performance of its delivery obligations shall render the supplier liable to the imposition of penalties, pursuant to GCC Clause 22, unless an extension of time is agreed upon pursuant to GCC Clause 22.2 without the application of penalties.
- 21.5 Upon any delay beyond the delivery period in the case of a goods contract, the purchaser shall, without cancelling the contract, be entitled to purchase goods of a similar quality and up to the same quantity in substitution of the goods not supplied in conformity with the contract and to return any goods delivered later at the supplier's expense and risk, or to cancel the contract and buy such goods as may be required to complete the contract and without prejudice to his other rights, be entitled to claim damages from the supplier.
- 22. Penalties**
- 22.1 Subject to GCC Clause 25, if the supplier fails to deliver any or all of the goods or to perform the services within the period(s) specified in the contract, the purchaser shall, without prejudice to its other remedies under the contract, deduct from the contract price, as a penalty, a sum calculated on the delivered price of the delayed goods or unperformed services using the current prime interest rate calculated for each day of the delay until actual delivery or performance. The purchaser may also consider termination of the contract pursuant to GCC Clause 23.
- 23. Termination for default**
- 23.1 The purchaser, without prejudice to any other remedy for breach of contract, by written notice of default sent to the supplier, may terminate this contract in whole or in part:
- if the supplier fails to deliver any or all of the goods within the period(s) specified in the contract, or within any extension thereof granted by the purchaser pursuant to GCC Clause 21.2;
 - if the supplier fails to perform any other obligation(s) under the contract; or
 - if the supplier, in the judgement of the purchaser, has engaged in corrupt or fraudulent practices in competing for or in executing the contract.
- 23.2 In the event the purchaser terminates the contract in whole or in part, the purchaser may procure, upon such terms and in such manner, as it deems appropriate, goods, works or services similar to those undelivered, and the supplier shall be liable to the purchaser for any excess costs for such similar goods, works or services. However, the supplier shall continue performance of the contract to the extent not terminated.
- 23.3 Where the purchaser terminates the contract in whole or in part, the purchaser may decide to impose a restriction penalty on the supplier by prohibiting such supplier from doing business with the public sector for a period not exceeding 10 years.
- 23.4 If a purchaser intends imposing a restriction on a supplier or any person associated with the supplier, the supplier will be allowed a time period of not more than fourteen (14) days to provide reasons why the envisaged restriction should not be imposed. Should the supplier fail to respond within the stipulated fourteen (14) days the purchaser may regard the supplier as having no objection and proceed with the restriction.
- 23.5 Any restriction imposed on any person by the purchaser will, at the discretion of the purchaser, also be applicable to any other enterprise or any partner, manager, director or other person who wholly or partly exercises or exercised or may exercise control over the enterprise of the first-mentioned person, and with which enterprise or person the first-mentioned person, is or was in the opinion of the purchaser actively associated.
- 23.6 If a restriction is imposed, the purchaser must, within five (5) working days of such imposition, furnish the National Treasury, with the following information:
- the name and address of the supplier and / or person restricted by the purchaser;
 - the date of commencement of the restriction
 - the period of restriction; and
 - the reasons for the restriction.
- These details will be loaded in the National Treasury's central database of suppliers or persons prohibited from doing business with the public sector.
- 23.7 If a court of law convicts a person of an offence as contemplated in sections 12 or 13 of the Prevention and Combating of Corrupt Activities Act, No. 12 of 2004, the court may also rule that such person's name be endorsed on the Register for Tender Defaulters. When a person's name has been endorsed on the Register, the person will be prohibited from doing business with the public sector for a period not less than five years and not more than 10 years. The National Treasury is empowered to determine the period of restriction and each case will be dealt with on its own merits. According to section 32 of the Act the Register must be open to the public. The Register can be perused on the National Treasury website.
- 24. Antidumping and countervailing duties and rights**
- 24.1 When, after the date of bid, provisional payments are required, or anti-dumping or countervailing duties are imposed, or the amount of a provisional payment or anti-dumping or countervailing right is increased in respect of any dumped or subsidized import, the State is not liable for any amount so required or imposed, or for the amount of any such increase. When, after the said date, such a provisional payment is no longer required or any such anti-dumping or countervailing right is abolished, or where the amount of such provisional payment or any such right is reduced, any such favourable difference shall on demand be paid forthwith by the supplier to the purchaser or the purchaser may deduct such amounts from moneys (if any) which may otherwise be due to the supplier in regard to goods or services which he delivered or rendered, or is to deliver or render in terms of the contract or any other contract or any other amount which may be due to him.
- 25. Force Majeure**
- 25.1 Notwithstanding the provisions of GCC Clauses 22 and 23, the supplier shall not be liable for forfeiture of its performance security, damages, or termination for default if and to the extent that his delay in performance or other failure to perform his obligations under the contract is the result of an event of force majeure.
- 25.2 If a force majeure situation arises, the supplier shall promptly notify the purchaser in writing of such condition and the cause thereof. Unless otherwise directed by the purchaser in writing, the supplier shall continue to perform its obligations under the contract as far as is reasonably practical, and shall seek all reasonable alternative means for performance not prevented by the force majeure event.
- 26. Termination for insolvency**
- 26.1 The purchaser may at any time terminate the contract by giving written notice to the supplier if the supplier becomes bankrupt or otherwise insolvent. In this event, termination will be without compensation to the supplier, provided that such termination will not prejudice or affect any right of action or remedy, which has accrued or will accrue thereafter to the purchaser.

27. Settlement of Disputes

- 27.1 If any dispute or difference of any kind whatsoever arises between the purchaser and the supplier in connection with or arising out of the contract, the parties shall make every effort to resolve amicably such dispute or difference by mutual consultation.
- 27.2 If, after thirty (30) days, the parties have failed to resolve their dispute or difference by such mutual consultation, then either the purchaser or the supplier may give notice to the other party of his intention to commence with mediation. No mediation in respect of this matter may be commenced unless such notice is given to the other party.
- 27.3 Should it not be possible to settle a dispute by means of mediation, it may be settled in a South African court of law.
- 27.4 Notwithstanding any reference to mediation and/or court proceedings herein,
- (a) the parties shall continue to perform their respective obligations under the contract unless they otherwise agree; and
 - (b) the purchaser shall pay the supplier any monies due the supplier for goods delivered and / or services rendered according to the prescripts of the contract.

28. Limitation of Liability

- 28.1 Except in cases of criminal negligence or wilful misconduct, and in the case of infringement pursuant to Clause 6;
- (a) the supplier shall not be liable to the purchaser, whether in contract, tort, or otherwise, for any indirect or consequential loss or damage, loss of use, loss of production, or loss of profits or interest costs, provided that this exclusion shall not apply to any obligation of the supplier to pay penalties and/or damages to the purchaser; and
 - (b) the aggregate liability of the supplier to the purchaser, whether under the contract, in tort or otherwise, shall not exceed the total contract price, provided that this limitation shall not apply to the cost of repairing or replacing defective equipment.

29. Governing language

- 29.1 The contract shall be written in English. All correspondence and other documents pertaining to the contract that is exchanged by the parties shall also be written in English.

30. Applicable law

- 30.1 The contract shall be interpreted in accordance with South African laws, unless otherwise specified.

31. Notices

- 31.1 Every written acceptance of a bid shall be posted to the supplier concerned by registered or certified mail and any other notice to him shall be posted by ordinary mail to the address furnished in his bid or to the address notified later by him in writing and such posting shall be deemed to be proper service of such notice.
- 31.2 The time mentioned in the contract documents for performing any act after such aforesaid notice has been given, shall be reckoned from the date of posting of such notice.

32. Taxes and duties

- 32.1 A foreign supplier shall be entirely responsible for all taxes, stamp duties, license fees, and other such levies imposed outside the purchaser's country.
- 32.2 A local supplier shall be entirely responsible for all taxes, duties, license fees, etc., incurred until delivery of the contracted goods to the purchaser.
- 32.3 No contract shall be concluded with any bidder whose tax matters are not in order. Prior to the award of a bid SARS must have certified that the tax matters of the preferred bidder are in order.
- 32.4 No contract shall be concluded with any bidder whose municipal rates and taxes and municipal services charges are in arrears.

33. Transfer of Contracts

- 33.1 The contractor shall not abandon, transfer, cede assign or sublet a contract or part thereof without the written permission of the purchaser.

34. Amendment of contracts

- 34.1 No agreement to amend or vary a contract or order or the conditions, stipulations or provisions thereof shall be valid and of any force unless such agreement to amend or vary is entered into in writing and signed by the contracting parties. Any waiver of the requirement that the agreement to amend or vary shall be in writing, shall also be in writing.

35. Prohibition of restrictive practices

- 35.1 In terms of section 4 (1) (b) (iii) of the Competition Act No. 89 of 1998, as amended, an agreement between, or concerted practice by, firms, or a decision by an association of firms, is prohibited if it is between parties in a horizontal relationship and if a bidder(s) is / are or a contractor(s) was / were involved in collusive bidding.
- 35.2 If a bidder(s) or contractor(s) based on reasonable grounds or evidence obtained by the purchaser has / have engaged in the restrictive practice referred to above, the purchaser may refer the matter to the Competition Commission for investigation and possible imposition of administrative penalties as contemplated in section 59 of the Competition Act No 89 Of 1998.
- 35.3 If a bidder(s) or contractor(s) has / have been found guilty by the Competition Commission of the restrictive practice referred to above, the purchaser may, in addition and without prejudice to any other remedy provided for, invalidate the bid(s) for such item(s) offered, and / or terminate the contract in whole or part, and / or restrict the bidder(s) or contractor(s) from conducting business with the public sector for a period not exceeding ten (10) years and / or claim damages from the bidder(s) or contractor(s) concerned.

SECTION 6: SPECIAL/ADDITIONAL CONDITIONS OF CONTRACT

The **Conditions of Contract** make reference to the **Special Conditions of Contract (SCC)** for details that apply specifically to this bid. The **SCC** shall have precedence in the interpretation of any ambiguity or inconsistency between it and the **Conditions of Contract**.

Each item below is cross-referenced to the clause in the **Conditions of Contract** to which it mainly applies.

SCC 1.2 CONTRACT

- a) This contract commencement and termination date is based on the date of signature of the letter of award (LOA).
- b) The current contract termination date is 2025-02-10. In the event of the LOA being issued before 2025-02-10, then the commencement date shall be 2025-02-11.
- c) The termination date will be 36 months thereafter.

SCC 7.1 PERFORMANCE SECURITY

The liability of the Performance Security shall be Nil.

SCC 9.2 PACKAGING

All items shall be packaged in a way that will prevent damage or deterioration during transport, handling and storage. Refer to **clause 4.0** of the technical specification for details.

SCC 10.1 DELIVERY AND DOCUMENTS

Delivery of goods shall be by road to eThekweni Electricity, Main Store, 11 Electron Road, (off Umgeni Road), Springfield, Durban.

SCC 12.1 TRANSPORTATION

The cost of transport shall be amortised into the bid price of the items. No additional transport costs shall be entertained.

SCC 15.2 WARRANTY

All items shall be free from defect and carry a 12-month warranty.

SCC 16.1 PAYMENT

The Contractor shall submit to the Department concerned a detailed account which shall reflect the identifying number of each item/service. Payment will be made on this account when checked and substantiated by the authorised official.

Payment for goods received and accepted by the Municipality shall be made no later than 30 days after submission of invoice or claim, provided however that all the terms of the contract are duly complied with.

Payment will be made only to the supplier. Factoring arrangements will not be accepted.

SCC 17 PRICES

Price(s) submitted on the **OFFICIAL TENDER FORM** shall be based on one or a combination of the following:

- i) Rates of exchange, with the base rate as that published by a reputable South African bank seven-days prior to bid closing;
- ii) SEIFSA indices, with indices as that published by SEIFSA two-months prior to bid closing; or
- iii) CPI per province (KwaZulu-Natal) as specified on **Table A (Consumer Price Index: Main indices) of Statistical Release P0141**, as that published by Statistics South Africa two-months prior to bid closing.

A) RATES OF EXCHANGE

The first adjustment of the price(s) declared on the **OFFICIAL TENDER FORM** shall be undertaken when the Contractor(s) receives the first "Official Purchase Order", on condition that:

- a) The Contractor(s), within seven-days of receiving the "Official Purchase Order", arranges "forward exchange cover" i.e. fixing the rate of exchange;
- b) The "forward exchange cover" is arranged via a reputable South African bank; and
- c) The "forward exchange cover" shall be firm for the first month from the date of the "Official Purchase Order".

Hence, the first adjustment of price(s) declared on the **OFFICIAL TENDER FORM** shall take into account any variation in the rates of exchange between the following dates:

- i) The date of the base rate as that published by a reputable South African bank seven days prior to bid closing; and
- ii) The date the "forward exchange cover" is arranged after the first "Official Purchase Order".

The adjustment of price(s) shall then be undertaken for subsequent orders provided that the Contractor(s) arranges "forward exchange cover" via a reputable South African bank after each order. The price difference shall be paid or deducted by the Municipality in correlation with any increase or decrease in the basic rate of exchange.

Upon the failure of the Contractor(s) to arrange "forward exchange cover", the Contractor(s) shall be liable should there be an increase in the basic rate of exchange occurring after the last-mentioned date.

B) SEIFSA INDICES

The first adjustment of the price(s) declared on the **OFFICIAL TENDER FORM** shall be undertaken when the Contractor(s) receives the first "Official Purchase Order" and shall take into account any variation in indices between the:

- i) indices published by SEIFSA two-months prior to bid closing; and
- ii) indices published by SEIFSA two-months prior to the date of the first "Official Purchase Order".

The adjustment of price(s) for subsequent orders shall then be undertaken on the date of every order in accordance with the respective indices, two-months prior, as those published by SEIFSA.

C) CONSUMER PRICE INDEX (CPI)

The first adjustment of the price(s) declared on the **OFFICIAL TENDER FORM** shall be undertaken when the Contractor(s) receives the first "Official Purchase Order" and shall take into account any variation in the CPI between the:

- i) CPI published by Statistics South Africa two-months prior to bid closing; and
- ii) CPI published by Statistics South Africa two-months prior to the date of the first "Official Purchase Order".

The adjustment of price(s) for subsequent orders shall then be undertaken on the date of every order in accordance with the CPI per province (KwaZulu-Natal) as specified on **Table A (Consumer Price Index: Main indices) of Statistical Release P0141**, two-months prior, as those published by Statistics South Africa.

SCC 21.1 DELAYS IN THE SUPPLIER'S PERFORMANCE

The time schedule for the delivery of goods and performance of services is detailed in the **Delivery Periods Schedule of ACT 9**.

SCC 22.1 PENALTIES

If the supplier fails to deliver any or all of the goods or to perform the services within the period(s) specified in the **DELIVERY PERIODS SCHEDULE of ACT 9**, the purchaser shall, without prejudice to its other remedies under the contract, deduct from the contract price a penalty of 0,5 % per week of the order for each stock item that has not been supplied, and capped at 5 %. The purchaser may also consider termination of the contract pursuant to GCC Clause 23.

ADDITIONAL CONDITIONS OF CONTRACT
ACC1 PERFORMANCE MONITORING AND ASSESSMENT OF SERVICE PROVIDERS

For contract awards that are greater than R10M, the Supplier shall be subjected to "Performance Monitoring" assessments in terms of the applicable Section of the Council's current Supply Chain Management Policy.

ACC2 QUALITY OF PRODUCTS

No inferior products will be accepted during the period of this contract.

Should there be any cause for complaint against the standard of service or quality of products offered which is not resolved within a period of 10 working days, the Municipality reserves the right to cancel the contract after serving one month's notice, in writing, to the Supplier involved. Should such notice be given, the supplier shall nevertheless be obliged to perform the duties covered by the contract up to the date of expiration of the period of notice.

ACC3 COMPENSATION FOR OCCUPATIONAL INJURIES AND DISEASES (COID) ACT NO. 130 of 1993

This act replaces the Workmen's Compensation Act.

The Supplier shall, before commencement of work, produce documentary proof to the Head: Electricity, that he/she has complied in all respects with the provisions of the COID Act. The Supplier undertakes that he/she will perform and comply with all provisions of the COID Act and more particularly that he/she will render all returns and pay all assessments for which he/she is liable in terms of such Act.

ACC4 DAMAGE TO PERSONS AND PROPERTY

- (1) The Supplier **shall** indemnify and keep indemnified the Council against any claim for death, injury, damage or loss to any person or property whatsoever in respect thereof or in relation thereto.
- (2) The Supplier enters into this contract as an independent Contractor and shall be solely liable in respect of any claim for death, injury, damage or loss to any person or property whatsoever in respect thereof or in relation thereto.

ACC5 ESTIMATED QUANTITIES

The quantities stated in **SECTION 8** are applicable for evaluation purposes only. The final quantity of goods and services required shall vary, depending on the total number of actual instances a service/goods will be required over the contract period. The rates tendered shall be applicable, irrespective of the total quantity of goods and services procured over the contract duration.

SECTION 7: SCOPE OF SUPPLY AND SPECIFICATION**1.0 SCOPE OF SUPPLY**

This specification details the manufacture, testing, supply, delivery and off-loading of staywires and associated components.

2.0 NORMATIVE REFERENCES AND OPERATING CONDITIONS

2.1 The following normative references contain provisions which, through reference in this text, constitute requirements of this specification:

Table 1 – Normative references

NRS 022: 2014	Stays and associated components
SANS 121: 2011	Hot dip galvanised coatings on fabricated iron and steel articles
SANS 182-5: 2008	Conductors for overhead electrical transmission lines, Part 5: Zinc-coated steel wires for conductors and stays
SANS 1091: 2012	National colour standard
SANS 10244-2: 2011	Steel wire and wire products – Non-ferrous metallic coatings on steel wire, Part 2: Zinc or zinc alloy coatings
SANS 12944-2:1998	Paints and varnishes – Corrosion protection of steel structures by protective paint systems, Part 2: Classification of environments
SANS 50025: 2009	Hot rolled products of structural steels

Bidders shall note that, as all normative references are subject to revision, they are encouraged to investigate the possibility of applying the most recent edition of the above references.

2.2 The operating conditions detailed in Table 2 shall be taken into account when designing the products detailed in this specification to ensure these items will operate satisfactorily for the duration of its design life.

Table 2 – Operating conditions

Altitude	sea-level to 1 000 m
Ambient temperature – Minimum	0 °C
Ambient temperature – Maximum	40 °C
Ambient temperature – Average	35 °C measured over a period of 24 h
Atmospheric-corrosivity category	C5 in accordance with SANS 12944-2
Basic impulse insulation level	95 kV
Climate	humid, heavily salt-laden and sub-tropical
Highest system phase-to-phase voltage	12 kV
Lightning level/lightning ground flash density	High/up to 5 flashes per km ² per year
Pollution type	Very heavy marine and industrial
Rainfall – Average annual	1 000 mm
Relative humidity – Average	95 % measured over a period of 24 h
Solar radiation (mean annual value)	1,0 kW/m ²
System frequency	50 Hz
Wind speeds	31 m/s

3.0 REQUIREMENTS

The staywires and associated components shall fully comply with the requirements detailed in NRS 022, except where modified in the specification below.

3.1 Stay-anchor assemblies

- The stay-anchor assemblies, comprising of an anchor-rod and a stay-plate, shall conform to the dimensions detailed in **Figure 1**. Hexagonal stay plates in accordance with NRS 022 shall also be considered.
- The stay-anchor assembly shall be hot-dip galvanised in accordance with the requirements detailed in SANS 121, where the minimum thickness of the zinc shall be 85 µm. The stay-anchor assemblies shall be galvanised after all cutting, punching, welding and other operations have been completed.
- The stay-anchor assembly, particularly the eye of the anchor-rod and the slot in the stay-plate, shall be smooth and clean and shall be free from defects such as burrs, sharp edges, excess galvanising,

- excess weld-material, etc.
- d) The stay-anchor assembly shall have a minimum breaking load of 94 kN.
 - e) The stay anchor-rod shall be manufactured from a continuous length of steel with a 350WC grade, or equivalent, and the anchor-rod shall not be spliced.
 - f) The diameter of the stay anchor-rod shall be 20 mm prior to being hot-dip galvanised.
 - g) The eye at the top of the anchor-rod shall be forged, as detailed in **Figure 1**, or welded (as per NRS 022:2014).
 - h) The following information shall be indented or embossed on each stay-anchor:
 - i) The manufacturer's name or trade mark;
 - ii) The manufacturer's identification reference; and
 - iii) The minimum breaking load.
- i) A formal test report detailing test procedures and test results shall be submitted to confirm that the stay anchor assemblies have met or exceeded the requirements of 94 kN above. The test shall be carried out by securing the stay-plate in such a manner that the welds on the integral stay-plate, the eye and the rod material are subjected to the 94 kN test load.

3.2 Thimbles

- a) The thimbles shall conform to the dimensions detailed in **Figure 2**.
- b) The thimbles shall be made of steel with a 350WC grade, or equivalent.
- c) The thimbles shall be hot-dip galvanised in accordance with the requirements detailed in SANS 121, where the minimum thickness of the zinc shall be 55 µm. The thimbles shall be galvanised after all cutting, bending, punching and other operations have been completed.
- d) The thimbles, particularly the thimble groove shall be smooth, clean and free from defects such as burrs, sharp edges, excess galvanising, etc.

3.3 Guy grip dead-end fittings

- a) The guy grip dead-end fittings shall be manufactured from steel wire which is hot-dip galvanised in accordance with SANS 10244-2.
- b) The guy grip dead-end fittings shall be capable of being removed and re-applied to the staywire a minimum of three times on a new construction, for the purpose of stay adjustment. The glue binder shall be of a quality that ensures that the wires remain intact, facilitating installation and removal.
- c) A formal test report detailing test procedures and test results shall be submitted to confirm that the samples have met or exceeded the requirements detailed in NRS 022.

3.4 Staywires

- a) The staywires shall fully comply with the requirements detailed in NRS 022.
- b) The required staywire sizes and strengths shall be as that detailed in **Returnable Documents 5 and 6**.
- c) The staywires shall be hot-dip galvanised in accordance with SANS 10244-2.
- d) The staywires shall be packed in coils of 30 m having a suitable inside diameter and shall be securely bound with binders that shall cause no harm or have any corrosive effect on the wires.
- e) The coils shall be marked in accordance with SANS 182-5.

3.5 Testing of staywires

- a) The samples for testing of staywires shall be chosen in accordance with SANS 182-5.
- b) The samples shall be subjected to the following tests which shall be carried out in accordance with SANS 182-5:
 - i) breaking strength tests; and
 - ii) zinc-coating tests.
- c) After testing of the samples, the number of defects found shall not exceed the respective number given in SANS 182-5.
- d) A formal test report detailing the test procedures and test results shall be submitted to confirm that the samples have met or exceeded the requirements of SANS 182-5.

3.6 Stay insulators

- a) The stay insulators shall fully comply with the electrical characteristics and ultimate breaking strength requirements detailed in NRS 022, except where modified below.
- b) The design of the staywire and associated components shall be such that when they are exposed to the conditions detailed in **clause 2.2** of this specification, the materials shall not deteriorate to an extent whereby the overall performance and estimated lifespan of the design is affected.

- c) The porcelain stay insulator shall have integral thimble-type anchoring points and the guy strain stay insulator shall have thimble end fittings where:
 - i) the eyes of the thimble shall be of a diameter to allow easy entry of the guy grip dead-end fitting (refer to **clause 3.3**); and
 - ii) the radius of curvature of the thimble grooves shall be designed to seat the guy grip dead-end fitting (refer to **clause 3.3**) without undue mechanical stress on the guy grip dead-end fitting.
- d) The insulators shall be marked in accordance with the requirements for stay insulators detailed in NRS 022. The markings shall be of a type and position so as **not** to have any electrical, physical and any other implications on the insulator.

3.7 Porcelain stay insulators

- a) The porcelain stay insulators shall be similar in design to the illustration detailed in **Figure 3**, where the dimensions are typical only and shall have a minimum leakage distance of 76 mm.
- b) The insulation material shall be glazed porcelain.
- c) The porcelain stay insulators, particularly the thimble-type grooves, shall be smooth, clean and free from defects such as unglazed surfaces, burrs, sharp edges, etc.
- d) A formal test report, conducted by a recognised testing authority, detailing test procedures and test results shall be submitted to confirm that the porcelain stay insulators have met or exceeded the stay insulator requirements detailed in NRS 022.

3.8 Guy strain stay insulators

- a) The guy strain stay insulators shall be similar in design to the illustration detailed in **Figure 4**, where the dimensions are typical only.
- b) The guy strain stay insulator shall have a flexible UV-resistant moisture seal which shall prevent any ingress of moisture between the end fittings and the fibreglass member.
- c) The fibreglass member of the guy strain insulators shall be light grey, equivalent to colour code G29 of SANS 1091.

3.9 End fittings of the guy strain stay insulators

- a) The guy strain stay insulators shall have thimble end fittings.
- b) The thimble end fittings shall be made of ductile iron or other approved material which shall be hot-dip galvanised in accordance with the requirements of SANS 121, where the minimum thickness of the zinc shall be 55 µm.
- c) The thimble end fittings shall be suitably attached to the fibreglass member.
Note: Details of the method of attachment of the end fittings to the fibreglass rod shall be submitted with the bid documents.
- d) The thimble end fittings, particularly the thimble groove, shall be smooth, clean and free from defects such as burrs, sharp edges, excess galvanising, etc.

3.10 Insulation requirements of the guy strain stay insulators

- a) The insulation material between the thimble end fittings shall be a fibreglass rod or a similar insulating material which shall be protected against ultra-violet light degradation.
- b) A formal test report, conducted by a recognised testing authority, detailing test procedures and test results shall be submitted to confirm that the guy strain stay insulators have met or exceeded the stay insulator requirements of NRS 022 and **clause 3.9 (b)** of this specification.

3.11 Stay straps

- a) The stay straps shall conform to the dimensions detailed in **Figure 5**.
- b) The stay straps shall be hot-dip galvanised in accordance with the requirements of SANS 121, where the minimum thickness of the zinc shall be 55 µm. The stay straps shall be galvanised after all cutting, bending, punching, and other operations have been completed.
- c) The stay straps, particularly the holes, shall be smooth, clean and free from defects such as burrs, sharp edges, excess galvanising, etc.

4.0 PACKAGING

4.1 The staywires and associated components shall be carefully packaged to prevent damage or deterioration during transport, handling and storage.

4.2 The staywires and associated components shall be packaged and supplied as follows:

- a) The stay-anchors shall be delivered strapped together in bundles of 5 units each.
- b) The thimbles shall be delivered in sturdy containers or bags capable of withstanding heavy wear.

- The number of thimbles in each container or bag shall be 100.
- c) The guy grip dead-end fittings shall be delivered in cardboard boxes in quantities of 20 units.
 - d) The staywires shall be delivered in coils having lengths of 30 metres and shall be supplied stacked onto formers (or “dollies”).
 - e) The porcelain stay insulators shall be delivered in sturdy containers of 10 units each.
 - f) The guy strain stay insulators shall be delivered in sturdy boxes of 15 units each.
 - g) The stay straps shall be delivered in bags capable of withstanding heavy wear. The number of stay straps in each bag shall be 50.
- 4.3** All packages, containers and bags shall be indelibly marked with the following:
- a) The contract number;
 - b) The order number;
 - c) The supplier's trade name or trade mark or both;
 - d) The place of manufacture; and
 - e) The code name and description of the item.
- 5.0** **DOCUMENTATION**
- 5.1** Full technical and descriptive details, relating to all the items offered in this enquiry, shall be submitted so the offer can be evaluated fully. This shall include:
- a) Materials;
 - b) Details of quality assurance procedures;
 - c) Drawings; etc.
- 5.2** Failure to submit such information may preclude further consideration of the bid.
- 6.0** **SAMPLES**
- 6.1** The preferred Tenderers shall submit samples of the tendered items within one (1) week of request by eThekwini Electricity. These samples shall be delivered to eThekwini Electricity, Technology Services, 3rd Floor Smart Xchange Building, 5 Walnut Road, Durban, marked for the attention of Nazeer Vawda – Senior Engineer: Technology Services.
- 6.2** The samples submitted by Tenderers for each item shall be identical to the items offered on the respective **RETURNABLE DOCUMENTS 1 to 9** detailed in **ACT 9** and shall be labelled with the following information:
- a) Contract/Enquiry number;
 - b) Name of Tenderer;
 - c) Date of delivery; and
 - d) Item number corresponding with the respective **RETURNABLE DOCUMENT**.
- 6.3** Tenderers are required to note that bid documents must **not** be included in parcels containing samples.
- 6.4** EThekwini Electricity reserves the right to submit samples to tests as deemed reasonable and necessary. Tenderers shall collect and remove their samples within one month of being notified to do so, failing which they will be deemed to have waived all rights to the samples and such samples not collected after one month from the date of such notification will become the property of the eThekwini Municipality for disposal or use at its discretion.

7.0 DRAWINGS

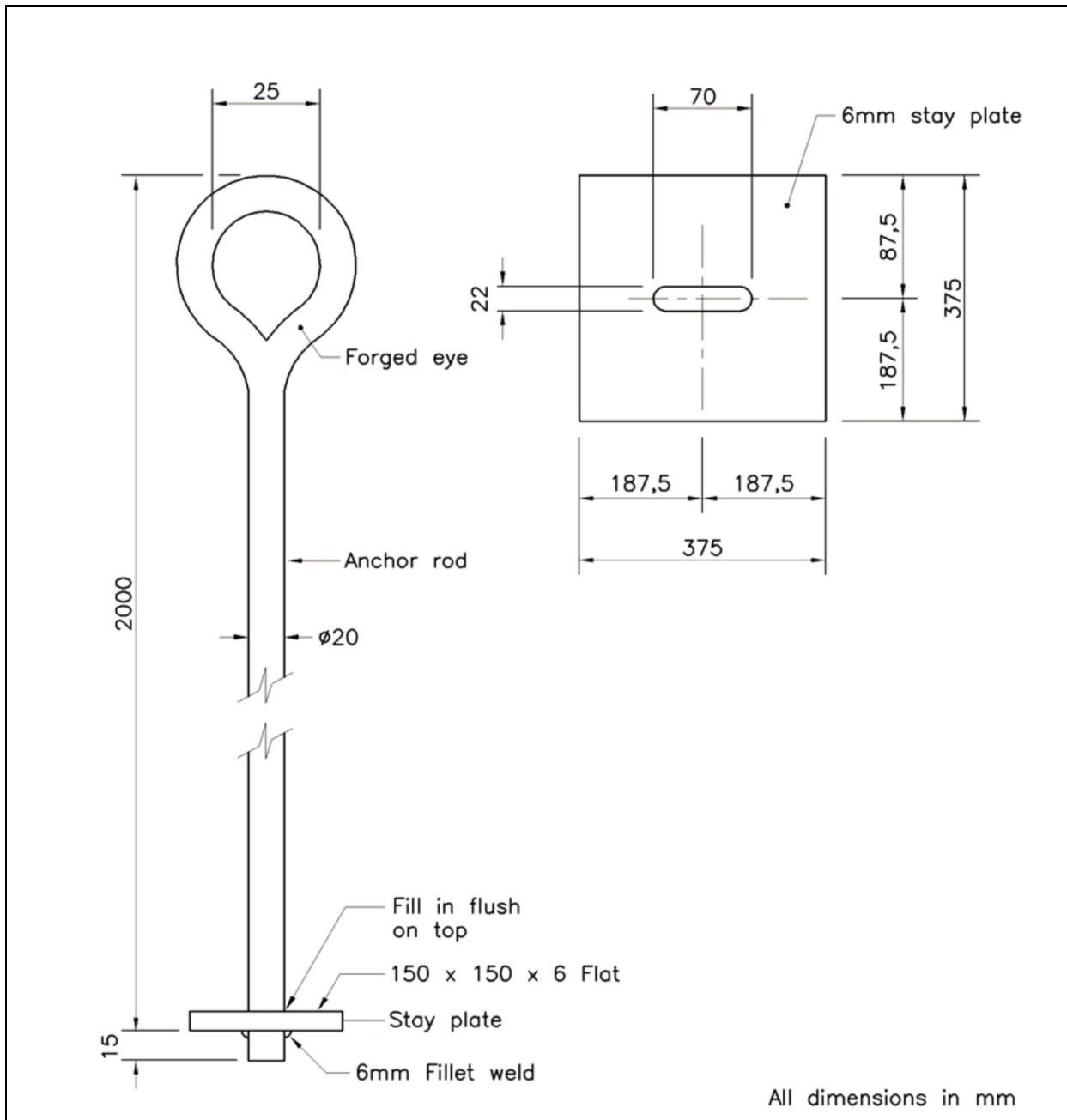

Figure 1 - Stay-anchor

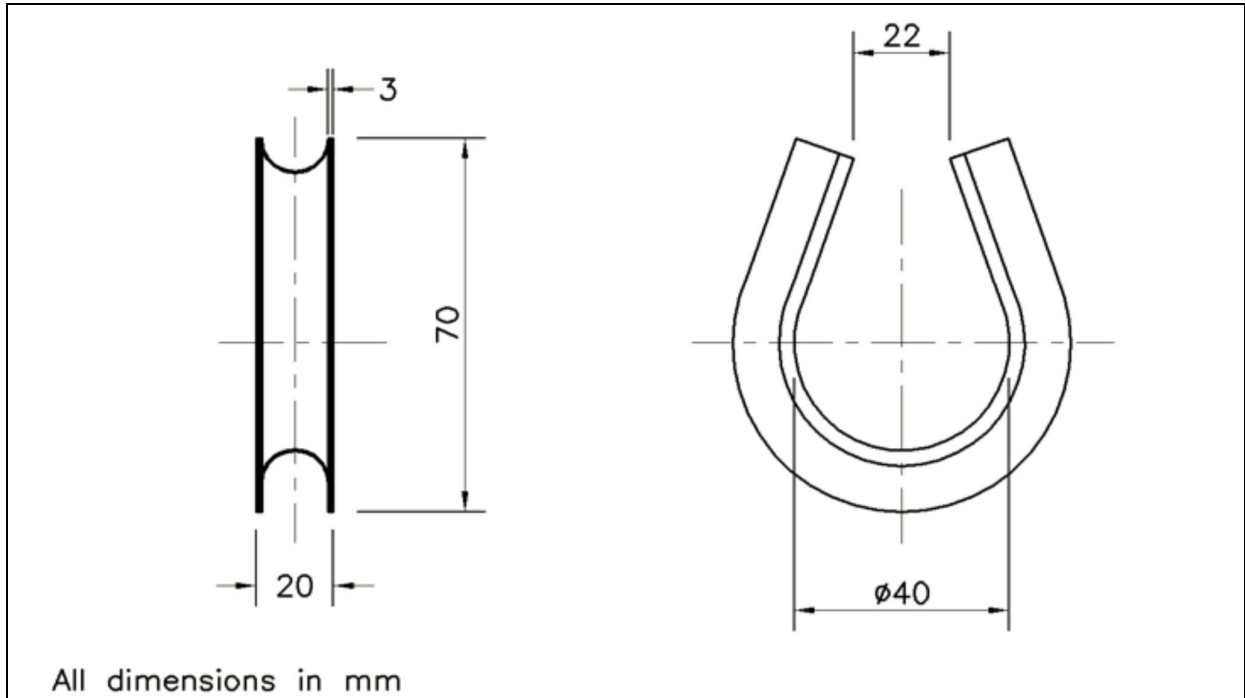

Figure 2 – Thimble

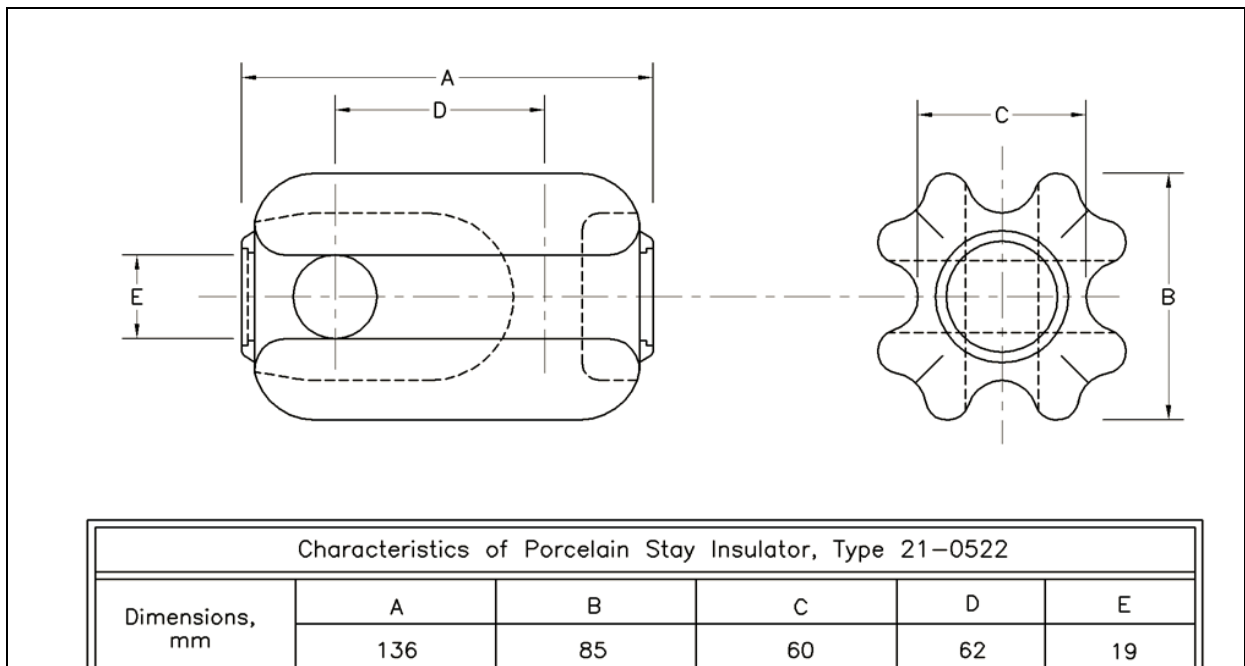

Figure 3 – Typical porcelain stay insulator

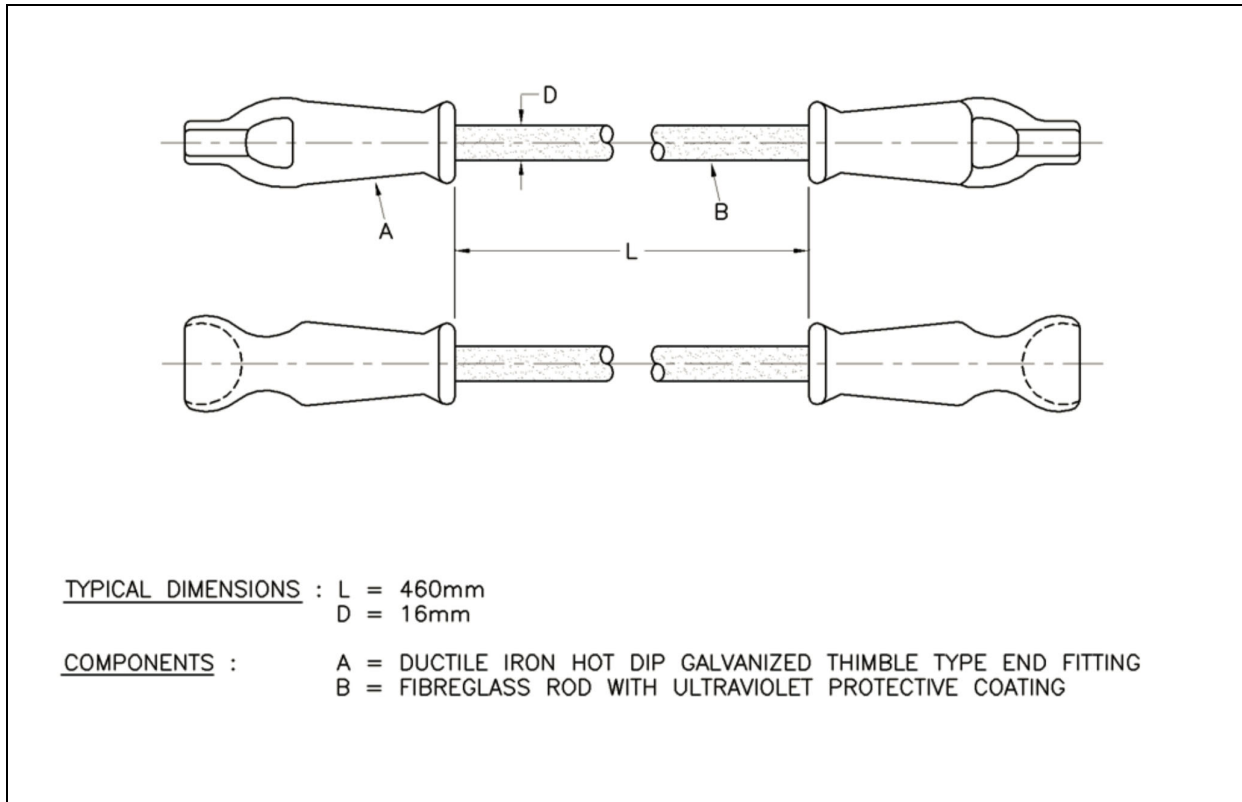

Figure 4 – Typical guy strain stay insulator

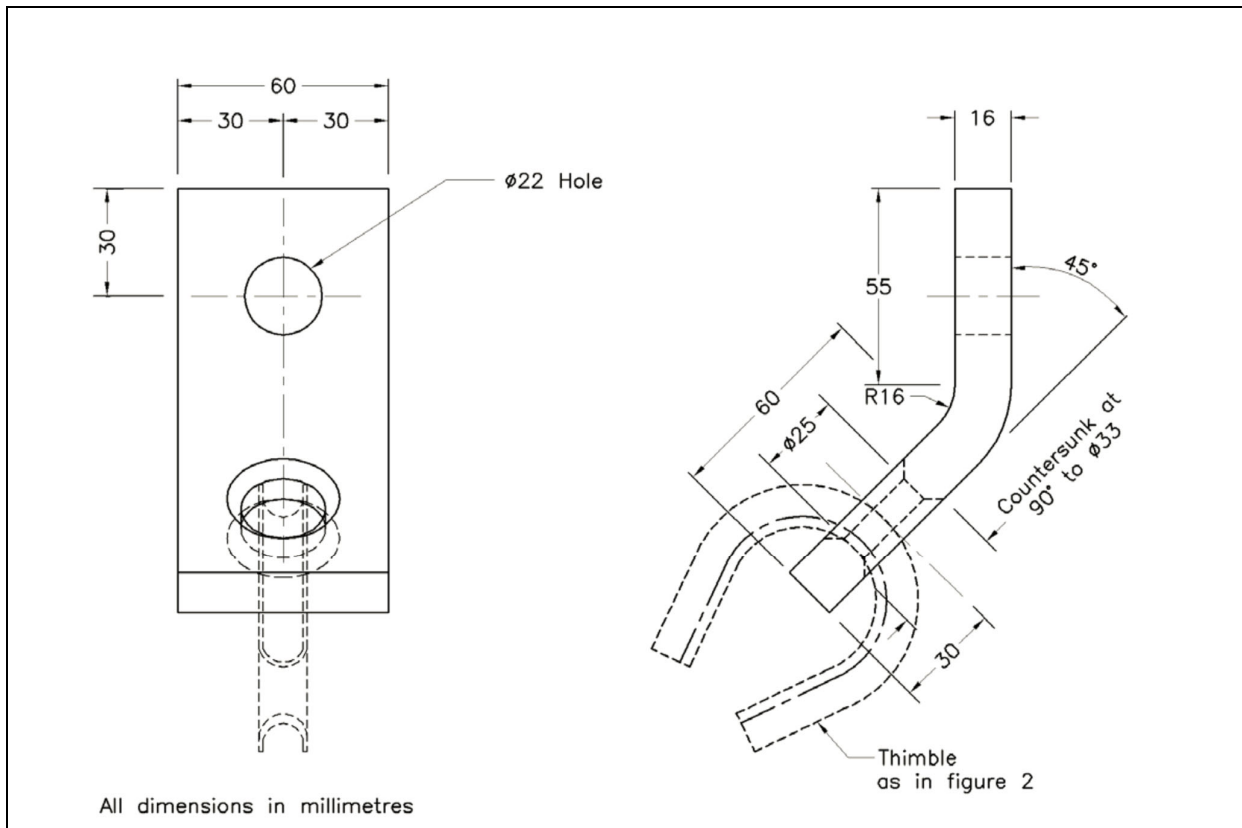

Figure 5 – Stay strap

SECTION 8: BILL OF QUANTITIES AND SCHEDULE OF RATES

Item	Description	Item Code	Annual Estimated Quantity Required	Unit of Measure	Unit Price Excluding VAT		VAT		Unit Price Including VAT	
					R	c	R	c	R	c
1	Stay-anchor 2 000 mm long × 20 mm diameter with 375 × 375 × 6 mm stay-plate	1419	1 450	Each						
2	Thimble	1628	3 700	Each						
3	Guy grip dead-end fitting for 3/4,00 mm, 700 MPa staywire	960	90	Each						
4	Guy grip dead-end fitting for 7/4,00 mm, 700 MPa staywire	961	10 500	Each						
5	Staywire 3/4,00 mm, 700 MPa, 30 m coils	1718	5 coils	30 m coils						
6	Staywire 7/4,00 mm, 700 MPa, 30 m coils	1720	900 coils	30 m coils						
7	Porcelain stay insulator, 70 kN failing load	1009	2 300	Each						
8	Guy strain stay insulator thimble type, 70 kN failing load	1008	630	Each						
9	Stay strap	1501	90	Each						

Note: 1) Unit prices to be completed in Schedule of Rates above.

2) For items 5 and 6: Unit prices to be completed are for a 30 m coil. (NOT A PER METER PRICE)

BIDDING
COMPANY: _____

NAME: _____

SIGNED: _____

CAPACITY OF
SIGNATORY: _____

DATE: _____

YYYY - MM - DD

SECTION 9: OFFICIAL TENDER FORM

Part A: OFFER BY TENDERER - In response to **Tender Number: 29023-(5E)** I/we hereby offer to supply the goods/services detailed hereunder in accordance with the Technical Specification, and subject to the Standard and Special Conditions of Tender (Goods/Services), and General and Special Conditions of Contract, which accompanied your Tender (with which I/we acknowledge myself/ourselves to be fully acquainted) at the price stated in **Section 8: Bill Of Quantities and Schedule of Rates**.

I/We hereby agree that this tender will hold good and remain open for acceptance as specified in the Conditions of Tender or during such other period as may be specified in the Special Conditions of Tender.

eThekwini Vendor Portal Registration Number: PR

C.S.D Registration Number: MAAA

S.A.R.S Pin Number: _____

COMPLETION OF THE FOLLOWING IS COMPULSORY.
FAILURE TO DECLARE THE FOLLOWING WILL INVALIDATE YOUR OFFER.

Declaration of Interest

Are any of the entity's directors, managers, principle shareholder or stakeholders currently in the service of the state or have been in the service of the state in the past twelve (12) months? <input type="checkbox"/> Yes <input type="checkbox"/> No				
Is any spouse, child or parent of the entity's directors, managers, principle shareholder or stakeholder currently in the service of the state or have been in the service of the state in the past twelve (12) months? <input type="checkbox"/> Yes <input type="checkbox"/> No				
Name of entity's member	Position in Entity	Name of Relative (if applicable)	Name of State Institution	Nature of Relationship
Do you or any other directors, managers, principle shareholder or stakeholder of your entity have any relationship (spouse, family, friend, associate) with persons in the service of the state and/or who may be involved with the evaluation of this quotation? If yes please furnish particulars below <input type="checkbox"/> Yes <input type="checkbox"/> No				
Name of entity's member	Position in Entity	Name of Relative (if applicable)	Name of State Institution	Nature of Relationship

Refer to the Consolidated MBD Documents in Section 4(d) for the definition of "in service of the State"

*Signature: _____ *Name (capitals): _____

Date: YYYY - MM - DD Capacity: _____

*Name of Business: _____ Tel: _____

Address: _____ Fax: _____

*Denotes Mandatory Information

Failure to complete the Mandatory Information and sign this Tender Form will invalidate the tender.

Part B: ACCEPTANCE BY PURCHASER - The Purchaser, as represented by the following Official, hereby accepts the Tenderer's offer in terms of the Conditions of Tender, Specifications, and Conditions of Contract.

Signature: _____ Name (capitals): _____

Date: YYYY - MM - DD Capacity: _____