

POWER SUPPLY PROJECT

TEST BENCH 5

-SEE PAGE 4 FOR DETAILS

	TITLE AND DESCRIPTION
1.	<p>GENERAL</p> <p><i>DESCRIPTION:</i></p> <p>Power Supply Project focuses on the loading side of electric motors on test bench number 5, it completes the Power Supply Unit project which focuses on supplying three-phase and single-phase power to electric motors on different motors at different test benches. The main objective is to increase the testing scope of the Rotating Machines lab to meet the motor test demand of VC 9113, with an efficient and modern loading test bench for electric motors. It packages all necessary components, equipment, and systems (load/dyno/brake unit, transducer, mounting table, accessories, instruments, etc) for efficiently conducting tests on electric motors rated from 90 kW up to 400 kW. See the Specification for RM Test Benches on page 5 below, for this project, consider the values under Test Bench 5 only.</p> <p><i>LOCATION:</i></p> <p>Rotating Machines, Motor Laboratory</p> <p><i>APPLICATION:</i></p> <p>Test three-phase electric motors of different frame sizes, producing an output of 90 kW up to 400 kW.</p> <p><i>OUTPUT POWER RANGE:</i></p> <p>90 kW up to 400 kW</p> <p><i>TEST SPEED RANGE:</i></p> <p>0 – 3 000 rpm</p> <p><i>HEAVIEST TEST SAMPLE WEIGHT:</i></p> <p>4.5 tons</p>
2.	<p>TORQUE TRANSDUCER AND DISPLAY SPECIFICATION</p> <ul style="list-style-type: none">a. Read, display, and transmit*:<ul style="list-style-type: none">i. Output Power: 90 kW up to 400 kWii. Speed: Continuous running: 745 rpm – 3 000 rpm, Intermittent running: 0 – 3000 rpmiii. Torque: Up to 10 000 Nmb. The Transducer Unit should come with a valid calibration certificate issued by an accredited calibration lab—ILAC (International Laboratory Accreditation

	<p>Cooperation) accreditation. A manufacturer's calibration certificate is not sufficient unless accredited.</p> <p>c. Transducer Unit should be easily removable for future calibration purposes.</p> <p>(*) Transmit: The torque transducer and display system should have PC interfacing software, cables, and accessories for printing raw data.</p>
3.	<p>TORQUE TRANSDUCER SUPPORTING STRUCTURE #</p> <p>Testing process involves constant set up and set down of samples, almost twice a week. Due to this, depending on the type of the torque transducer, a supporting structure may be key to ensuring longevity of the transducer unit when motor samples are being swapped.</p>
4.	<p>COUPLING</p> <p>a. Motor testing requires set up for high precision speed measurement, made with materials capable of enduring the highest torque specified and high temperatures (up to 100 °C)</p> <p>b. Coupling accessories (joining torque transducer and loading unit):</p> <p>Refer to shaft sizes of the Transducer and loading unit (dyno/brake).</p> <p>c. Coupling accessories and pieces (joining torque transducer and sample):</p>
5.	<p>MOUNTING TABLE #</p> <p>FEATURES</p> <p>Automated table height management (raise and drop) / Easy and low-effort mechanical adjustments (height level based on shaft height) Electric motor shaft heights are standard – height level can be preset (low tolerance)</p> <p>Automated axial and horizontal angle management / Easy and low-effort mechanical adjustments (axial and horizontal angle alignment management based on motor shaft position vs torque transducer position)</p> <p>Accessories for mounting foot-mounted motor samples.</p> <p>Rigid table position locking.</p> <p>Stability on the floor.</p> <p>Vibration absorption base (minimise vibrations transferred to platform)</p> <p>3 angle indicators (transducer, axial, and horizontal angles on the motor)</p> <p>DIMENSIONS</p> <p>Refer to dimensions of 355 frame size and other sizes as per the Informative table below, Table 5.</p> <p>Height: ±1 m (bed level)</p>

7.	<p>EASILY AND EFFICIENTLY JOIN AND UNJOIN (MECHANICALLY) A MOTOR SAMPLE SHAFT TO THE TORQUE TRANSDUCER SHAFT</p> <p>Electric motor undergoes about 10 different tests on the test bench – some require the shafts of the motor and the torque transducer to be mechanically joined and some require the actions of unjoining the shafts and rigidly clamping the motor to the test bench to be performed speedily to continue with tests while the machine is still in hot (normal operating temperatures), examples are No-load tests, vibration tests, sound level tests, etc.</p> <p>Refer to point 3 and point 6, Torque transducer supporting structure and Mounting table.</p> <p>A feature that will enable the motor shaft to be disjoined from the torque transducer shaft (slide out) easily and efficiently without the use of lifting equipment (overhead crane) is key in ensuring that the tests may continue without the motor temperature dropping to cooler temperatures. This feature is also key in ensuring that the time spent to perform the actions of unjoining the shafts and rigidly clamping the motor to the test bench is shortened.</p>
8.	<p>LOADING/BRAKE/DYNAMOMETER UNIT</p> <p>Brake/Dynamometer (Electronically adjusted)</p> <ul style="list-style-type: none"> i. Output Power: 90 kW up to 400 kW ii. Speed: Continuous running: 745 rpm – 3 000 rpm, Intermittent running: 0 – 3000 rpm iii. Torque: Up to 10 000 Nm iv. Cooling: cooling system installation accessories (unless the loading unit is self-cooled) v. 2 - 3 brake unit temperature measuring points (display interface) vi. Brake unit protective device vii. Locked rotor mechanism
9.	<p>LOADING/BRAKE/DYNAMOMETER UNIT CONTROLLER</p> <p>Control device: e.g. Digital DC power supply (compatible with loading unit to achieve specified outputs) DC Load/torque stabilizer</p>
10.	<p>LOADING/BRAKE/DYNAMOMETER UNIT TABLE/SUPPORT STRUCTURE</p> <p>Rigid supporting structure Vibration absorption base (minimise vibrations transferred to platform)</p>
11.	<p>GUARD</p> <p>Shaft guard Keep all moving parts guarded Easy to open and close</p>
12.	<p>PORTABLE ALL-IN-ONE PC</p> <p>Monitor and record raw data. View standards. Compile raw data sheets. Compile test reports during testing</p>

SPECIFICATIONS FOR RM TEST BENCHES - INFORMATIVE

SPECIFICATION DESCRIPTION	TEST BENCH 101	TEST BENCH 102	TEST BENCH 1	TEST BENCH 2	TEST BENCH 3	TEST BENCH 4	TEST BENCH 5	
SAMPLES	<ul style="list-style-type: none"> ▪ Single-phase motors ▪ Series motors (Power tools) ▪ DC motors ▪ Universal motors (Power tools) 	<ul style="list-style-type: none"> ▪ Single-phase motors ▪ Series motors (Power tools) ▪ DC motors ▪ Universal motors (Power tools) 	<ul style="list-style-type: none"> ▪ Single-phase motors ▪ Three phase motors ▪ Series motors (Power tools) ▪ Universal motors (Power tools) 	<ul style="list-style-type: none"> ▪ Three phase motors ▪ Series motors (Power tools) ▪ Universal motors (Power tools) 	<ul style="list-style-type: none"> ▪ Three phase motors 	<ul style="list-style-type: none"> ▪ Three phase motors 	<ul style="list-style-type: none"> ▪ Three phase motors 	
TORQUE (Nm) (MIN) (SENSITIVITY)	0.15 Nm	0.15 Nm	2	5	±10	±10	±10	
TORQUE (Nm) [CALCULATED MAX] (TYPICAL TORQUE TRANSDUCER SENSOR)	[Notes: 0.76 – 4.71] (5 Nm)	[Notes: 3.18 – 9.55] (10-20 Nm)	[Notes: 7 – 19.1] (20-50 Nm)	[Notes: 19.1 – 140.1] (150 - 200 Nm)	[Notes: 95.49 – 701.96] (1 000 Nm)	[Notes: 573.88 – 2550.79] (3 000+ Nm)	[Notes: 1147.91 – 5101.98] (10 000+ Nm)	
TORQUE TRANSDUCER/SENSOR	± 38	± 38	± 38	± 80	± 100	110 +	110 +	
SHAFT SIZE (MIN) ±								
TORQUE TRANSDUCER SENSOR MIN RESOLUTION	0.1 Nm	0.1 Nm	0.1 Nm	1 Nm	±1 Nm	±1 Nm	±1 Nm	
RATED SPEED (RPM)	400 – 10 000+	400 – 10 000+	745 - 3000	745 - 3000	745 - 3000	745 - 3000	745 - 3000	
TYPICAL OUTPUT POWER (kW)	0.06 up to 0.37	0.25 up to 0.75	0.55 up to 1.5	1.5 up to 11	7.5 up to 55	45 up to 200	90 up to 400 kW	
DC POWER SUPPLY (where applicable)	<p>Option a: 4 dc power supply units with enough output to excite each Dynamometer coil of the relevant test bay.</p> <p>Option b: 2 channel 2 dc power supply units with enough output to excite all relevant Dynamometer coils on the 4 test benches at a time (capacity to provide above spec dc voltage and current ratings of Dynamometer coils). Individual channel controls to excite coils of each dynamometer at a time is mandatory.</p> <p>See TYPICAL LOADING/BRAKE/ DYN0 CONTROLLER below.</p>				<p><u>Option a (Suitable)</u> Guide: Suitable dc power supply unit.</p> <p>DC power supply V= Coil V x 2: _____</p>		<p><u>Option a (Suitable)</u> Guide: Suitable dc power supply unit.</p> <p>DC power supply V= Coil V x 2: _____</p>	
					<p><u>Option a:</u> 3 dc power supply units with enough output to excite each Dynamometer coil of the relevant test bay.</p>		<p><u>Option b:</u> 3 channel 1 dc power supply unit with enough output to excite all Dynamometer coils on the 3 test benches at a time (capacity to provide above spec dc voltage and current ratings of Dynamometer coils). Individual channel controls to excite coils of each dynamometer at a time is mandatory.</p>	

							See TYPICAL LOADING/BRAKE/ DYNO CONTROLLER below.
PROPOSED TEST BENCH POSITION WITHIN THE LAB, AND NOTES [ROOM NUMBER]	Next to Dimension T slot Table [EG34 and EG07]			Next to 400 kW test bench Dismantle and remove 18.5 kW test bench, move 7.5 kW and 1 kW bench [EG34]	Next to 400 kW test bench Dismantle and remove 18.5 kW test bench, move 7.5 kW and 1 kW bench [EG34]	1 MW test bench position Dismantle and remove 1 MW test bench [EG34]	
NUMBER OF POLES	NA		2, 4, 6, and 8 Poles	2, 4, 6, and 8 Poles	2, 4, 6, and 8 Poles	2, 4, 6, and 8 Poles	2, 4, 6, and 8 Poles
THREE PHASE CONNECTION POINT ⓐ (V @ 50 Hz) * (minimum available supply voltage)	NA		0 – 525	0 – 1.1 kV	0 – 1.1 kV	0 – 6.6 kV	0 – 6.6 kV
SINGLE PHASE CONNECTION POINT ⓑ (V @ 50 Hz) * (minimum available supply voltage)	0 – 255	0 – 255	0 – 255	0 – 255	N/A		
RATED CURRENT (A) (MINIMUM CONNECTION POINT LOAD CAPACITY) *	0 – 10 A	0 – 25 A	0 – 50 A	0 – 100 A	0 – 1 500 A	0 – 3000 A	0 – 3000
STEP DOWN DEVICE (CURRENT) (A) [POWER ANALYZER CONNECTION] (typical/suggested current transformer ratios)	Direct Connection – Power Analyzer	10 25/5 [5 A]	25/5 50/5 [5 A]	50/5 100/5 [5 A]	100/5 200/5 1000/5 [5 A]	200/5 1000/5 3000/5 [5 A]	1000/5 3000/5 [5 A]

STEP DOWN DEVICE (VOLTAGE) (V) [POWER ANALYZER CONNECTION] (typical/suggested transformer voltage ratio)	Direct Connection – Power Analyzer	Direct Connection – Power Analyzer	Direct Connection – Power Analyzer	1100 V / 400 V [400 V]	1100 V / 400 V [400 V]	6600 V / 400 V [400 V]	6600 V / 400 V [400 V]	
CONNECTION POINT WIRING NOTES	No step-down CT				Maximum of 1000/5 x 2 CTs available in the lab (Restrict utilization of more than 3000 A)	Maximum of 3000/5 x 1 CT available in the lab (Restrict utilization of more than 3000 A)		
FRAME SIZES (MAX EXPECTED)	80	132	180	315	355	355 ***	<i>[Notes: See NEMA frame sizes, and dimensions for indicated kW range]</i>	
CLAMPING ACCESSORIES	T-Slots and clamping screws/similar							
BOLTS (mounting accessories)	M10	M10	M12	M24	M27	M27 ***		
TABLE DIMENSIONS (meters) (LxW) (minimum dimensions)	0.6 x 0.5 +	0.6 x 0.5 +	1.5 x 1 +	1.5 x 1.3 +	3 x 2 +	3 x 2.8 + ***		
TYPICAL SAMPLE MASS (kg) (MAX)	50	100	200	1 000	2 000	4 500		
LOADING/BRAKE/ DYNO UNIT COOLING SYSTEM	Air	Air	Air/Other	Water/Other	Water/Other	Water/Other		
SHAFT SIZE SET (DIAMETER) (ALL) **	7, 9, 11, 14, 19, 24, 28, 38	7, 9, 11, 14, 19, 24, 28, 38	38, 42, 48, 55, 60	42, 48, 55, 60, 65, 70, 75, 80, 85, 90	80, 85, 90, 100, 110	80, 85, 90, 100, 110 ***		
LIFTING ACCESSORIES (mounting table, support structure, loading unit, etc)	Suitable eyebolts/lifting accessory for each item heavier than 10 kg	Suitable eyebolts/forklift slots for each heavy item (heavier than 10 kg)	Suitable eyebolts/forklift slots for each heavy item (heavier than 10 kg)	Suitable eyebolts/forklift slots for each heavy item (heavier than 10 kg)	Suitable eyebolts/forklift slots for each heavy item (heavier than 10 kg)	Suitable eyebolts/forklift slots for each heavy item (heavier than 10 kg)	Suitable eyebolts/forklift slots for each heavy item (heavier than 10 kg)	
MOUNTING TABLE MAIN FEATURES	<ul style="list-style-type: none"> Automated/ Easy and low-effort mechanical adjustments (height level, axial and horizontal balancing) 				<ul style="list-style-type: none"> Automated/ Easy and low-effort mechanical adjustments (height level, axial and horizontal balancing) 			
TYPICAL LOAD/BRAKE/ DYNO COOLING SYSTEM	<ul style="list-style-type: none"> Air/ Fan/ Blower/ Compressed IC01 (Open ventilated, no fan) IC411 (Totally Enclosed Fan Cooled (TEFC)) 				<ul style="list-style-type: none"> Water IC616 (Air-to-water heat exchanger (water-cooled)) 		<ul style="list-style-type: none"> Water IC616 (Air-to-water heat exchanger (water-cooled)) 	

MOTOR COOLING SYSTEM (Pump/Motor: SABS or equivalent test compliance required)	NA	NA	NA	Note: Utilize Table 4 or Table 5 Motor cooling system	Lower water flow <ul style="list-style-type: none"> ▪ Water cooling system ▪ Approved water pump (SA regulations / relevant standards) ▪ Approved digital water flow meters with flow and water temperature reading display (removable for calibration purposes) (SA regulations / relevant standards) ▪ Flexible inlet connection pipe and fitting ▪ All other necessary pipes ▪ New water tank/refurbishing of existing water tank ▪ High temperature flexible outlet connection pipe and fitting ▪ Water flow varying device ▪ Water flow: 20 – 100 L/min 	Lower and Higher water flow <ul style="list-style-type: none"> ▪ Water cooling system ▪ Approved water pump (SA regulations / relevant standards) ▪ Approved digital water flow meters with flow and water temperature reading display (removable for calibration purposes) (SA regulations / relevant standards) ▪ Flexible inlet connection pipe and fitting ▪ All other necessary pipes ▪ New water tank/refurbishing of existing water tank ▪ 2 High temperature flexible outlet connection pipes and fittings ▪ Water flow varying device ▪ First connection Water flow: 20 – 100 L/min ▪ Second connection Water flow: 100 – 400 L/min
ACCESSORIES: Portable All-in-One PC					Minimum Spec: CPU: Intel i5 10 th Gen or Intel i7 8 th Gen or equivalent Ryzen processor RAM: 16 GB Monitor: 20 inch Storage: 512 GB OS: Windows 11 Speakers and Mic (for MS Teams) Keyboard and Mouse	Minimum Spec: CPU: Intel i5 10 th Gen or Intel i7 8 th Gen or equivalent Ryzen processor RAM: 16 GB Monitor: 20 inch Storage: 512 GB OS: Windows 11 Speakers and Mic (for MS Teams) Keyboard and Mouse

(*) Informative. Power supply unit project (Electric Motor Transformer Project). Power supply unit is not part of this project

(**) Fitting and coupling project

(***) Research and confirm the following for 10 pole motors with 355 frame size:

See figure 1 below

(shaft size D , bolt size K , [foot length B size + CE size] * 1.8 = table dimension (wider side))

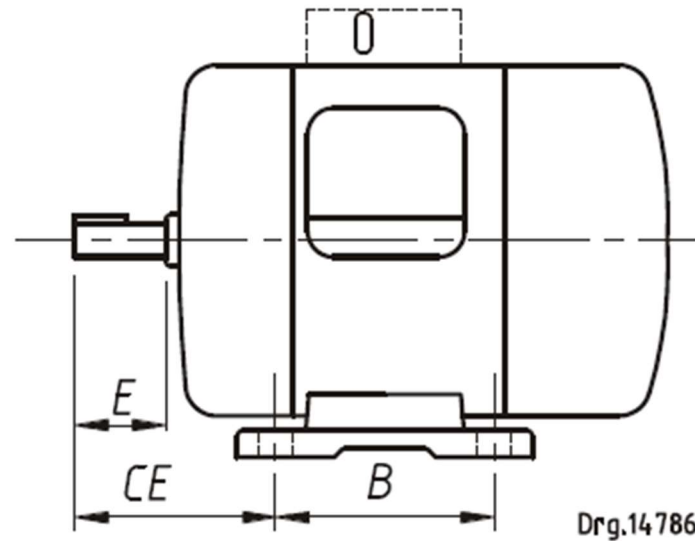
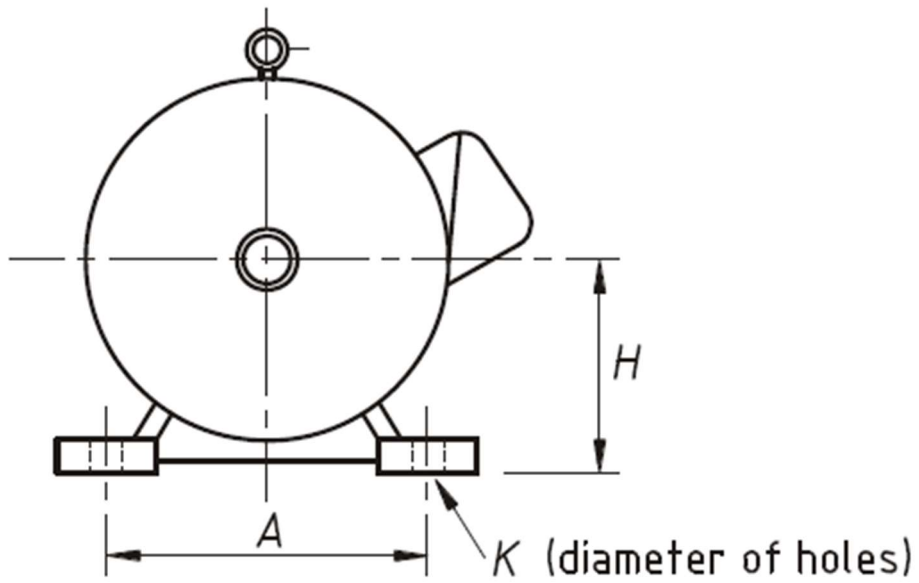

Drg.14786

Figure 1

Further notes:

Typical Transformer Secondary Voltages by Application

Voltage	Common Use Case	Notes
380V	European 3-phase systems	Often derived from 220V phase-to-neutral (Y config)
400V	IEC standard for 3-phase systems	Common in EU, Africa, Asia
415V	Australian and UK 3-phase systems	Used in commercial and light industrial settings
480V	North American industrial 3-phase	Derived from 277/480V wye systems
525V	South African heavy industrial systems	Used for motors and large machinery
1.1kV	Medium-voltage motor drives	Often used in mining and heavy industry
3.3kV / 3.1kV	Medium-voltage distribution	Common for large motors and substation feeders
6.6kV	Industrial substations, large motor drives	Used in mining, manufacturing, and utilities

IEC Induction Motor Ratings with Typical Mass

Power (kW)	Approx. Mass (kg)
0.06	5
0.09	6
0.12	7
0.18	9
0.25	11
0.37	13
0.55	16
0.75	19
1.1	24
1.5	28
2.2	33

3.0	40
4.0	50
5.5	65
7.5	80
9.2	95
11	110
15	135
18.5	160
22	185
30	230

37	270
45	320
55	370
75	470
90	550
110	650
132	750
160	850
200	1000
250	1200
315	1400
355	1600
400	1800

Power (kW)	Approx. Mass (kg)
450	2000
500	2200
560	2500
630	2800
710	3200
800	3600
900	4000
1000	4500