

Title: **SPECIFICATION FOR  
SUBSTATION CLAMPS FOR  
STRANDED ALUMINIUM  
CONDUCTORS**

Unique Identifier: **240-53113927**

Alternative Reference Number: **474-218**

Area of Applicability: **Engineering**

Documentation Type: **Standard**

Revision: **2**

Total Pages: **67**

Next Review Date: **October 2030**

Disclosure Classification: **Controlled  
Disclosure**

---

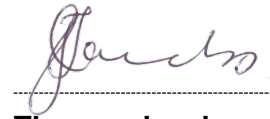
**Compiled by****Supported by****Approved by****Jason Blaauw****Theunus Marais****Thomas Jacobs****Dx Substation Products  
CG Chairperson****Chief Engineer, Substation  
Engineering****Senior Manager, Technology  
& Engineering (Acting)**Date: **30/09/2025**Date: **30/09/2025**Date: **02 October 2025**

---

**Supported by****Approved by****Authorised by****Rukesh Ramnarain****Subhas Maharaj****Sanjiv Kalicharan****NTCSA Substation  
Products CG Chairperson****Senior Manager, Substation  
Engineering****National SCOT Chairperson**Date: **30/09/2025**Date: **2/10/2025**Date: **03/10/2025**

## Content

	Page
1. Introduction .....	6
2. Supporting clauses .....	6
2.1 Scope .....	6
2.1.1 Purpose .....	6
2.1.2 Applicability .....	6
2.2 Normative/informative references .....	6
2.2.1 Normative .....	6
2.2.2 Informative .....	7
2.3 Definitions .....	7
2.3.1 General .....	7
2.3.2 Disclosure classification .....	8
2.4 Abbreviations .....	8
2.5 Roles and responsibilities .....	8
2.6 Process for monitoring .....	8
2.7 Related/supporting documents .....	8
3. Specification for Substation Clamps for Stranded Conductor .....	9
3.1 General .....	9
3.1.1 Service conditions .....	9
3.1.2 Technical information .....	9
3.2 Clamp types, dimensions and ratings .....	10
3.2.1 Type EX Clamps D-DT-6002 .....	11
3.2.2 Type EXC Clamps D-DT-6006 .....	11
3.2.3 Type EUT Clamps D-DT-6099 .....	11
3.2.4 Type ETC Clamps D-DT-6010 .....	12
3.2.5 Type EY Clamps D-DT-6022 .....	12
3.2.6 Type EYC Clamps D-DT-6013 and D-DT-6109 .....	12
3.2.7 Type EY3 Clamps D-DT-6007 .....	12
3.2.8 Type EYC3 Clamps D-DT-6008 .....	12
3.2.9 Type EPC Clamps D-DT-6018 .....	13
3.2.10 Type ES Spacers D-DT-6087 (Non-Current Carrying) .....	13
3.2.11 Type ESC Spacers D-DT-6087 (Current Carrying) .....	13
3.2.12 Type EXP Clamps D-DT-6027 .....	13
3.2.13 Type EXCP Clamps D-DT-6029 .....	13
3.2.14 Type EXCP2 Clamps D-DT-6025 .....	13
3.2.15 Type EXCP3 Clamps (No D-DT-drawing) .....	13
3.2.16 Type EYBC Clamps (No D-DT-number) .....	14
3.2.17 Type EPT Clamps D-DT-6004 .....	14
3.2.18 Type EPT2 Clamps D-DT-6005 .....	14
3.2.19 Type EPTT2 Clamps D-DT-6371 .....	14
3.2.20 Type EEP C Clamps D-DT-6115 .....	14
3.2.21 Type EESP Clamps D-DT-6003 .....	14
3.2.22 Type EPISF Clamps (No D-DT-number) .....	14
3.2.23 Type EYCT Clamps D-DT-6011 .....	14
3.2.24 Type EYCDT Clamps D-DT-6012 .....	14
3.2.25 Type ECJW Clamps D-DT-6014 .....	15

**ESKOM COPYRIGHT PROTECTED**

---

3.3	Technical Requirements .....	15
3.3.1	Materials.....	15
3.3.2	Machining.....	15
3.3.3	Bolted connections.....	15
3.3.4	Compression connections.....	16
3.3.5	Welded connections.....	17
3.3.6	Pad connections .....	17
3.3.7	PCD terminals.....	17
3.3.8	Electrical joint compound.....	17
3.3.9	Spacers.....	18
3.3.10	Rated continuous current.....	18
3.3.11	Rated short-circuit withstand current.....	18
3.3.12	Maximum Operating Temperature.....	18
3.3.13	Corona performance.....	18
3.3.14	Mechanical Strength .....	19
3.4	Tests.....	19
3.4.1	Type Tests (Clamps).....	19
3.4.2	Type Tests Acceptance Criteria (Clamps).....	20
3.4.3	Type Tests (Spacers).....	21
3.4.4	Type Test Acceptance Criteria (Spacers).....	22
3.4.5	Sample Tests (Clamps) .....	22
3.4.6	Sample Tests (Spacers) .....	23
3.4.7	Routine Tests (Clamps).....	23
3.4.8	Routine Tests (Spacers).....	23
3.4.9	Tests required per clamp family.....	23
3.4.10	Type Test Certificates and Reports .....	25
3.5	Drawings .....	25
3.6	Identification Marking .....	25
3.7	Inspection of Samples.....	26
3.8	Packaging.....	26
3.9	Off-loading and Storage Procedure .....	26
3.10	Installation .....	26
3.11	Inspections .....	26
3.12	Documentation .....	27
4.	Authorization.....	27
5.	Revisions .....	28
6.	Development team .....	29
7.	Acknowledgements .....	29
	Annex A – Clamp Types, sample drawings, dimensions and ratings .....	30
	Annex B – Technical Schedules A and B.....	62
	Annex C – Deviation Sheet to be completed for Tenders .....	67
<b>Figures</b>		
	Figure A.1: EX clamps.....	30
	Figure A.2: EXC clamp.....	31
	Figure A.3: EUT Clamp.....	32

---

Figure A.4: ETC Clamp.....	33
Figure A.5: EY Clamp.....	35
Figure A.6: EYC Clamp – Bolted Connection.....	36
Figure A.7: EYC Clamp – 8-Hole Pad Connection.....	37
Figure A.8: EYC Clamp – 9-Hole Pad Connection.....	38
Figure A.9: EY3 Type Bolted/Bolted Clamp for Stem Connection.....	39
Figure A.10: EYC3 Bolted/Compression Clamp for Stem Connection.....	40
Figure A.11: EYC3 Bolted/Compression Clamp for 8-Hole Pad Connection.....	41
Figure A.12: EYC3 Bolted/Compression Clamp for 9-Hole Pad Connection.....	42
Figure A.13: EPC Clamp 100x100mm Pad.....	43
Figure A.14: EPC Clamp 125x125mm Pad.....	44
Figure A.15: EPC Clamp Undrilled Pad.....	45
Figure A.16: ES Spacers.....	46
Figure A.17: ESC Spacer.....	47
Figure A.18: EXP Clamp.....	48
Figure A.19: EXCP Clamp.....	49
Figure A.20: EXCP2 Post Insulator mounted twin conductor support clamp.....	50
Figure A.21: EXCP3 Post Insulator mounted triple conductor clamp.....	51
Figure A.22: EYBC Clamp.....	52
Figure A.23: EPT Clamp.....	53
Figure A.24: EPT2 Clamp.....	54
Figure A.25: EPTT2 Twin conductor bolted support clamp on 8-hole pad to fit 8-hole terminal.....	55
Figure A.26: EEPC Clamp.....	56
Figure 27: EESP Clamp.....	57
Figure A.28: EPISF Post Insulator Stem fitting.....	58
Figure A.29: EYCT Clamp.....	59
Figure A.30: EYCDT Clamp.....	60
Figure A.31: ECJW Clamp.....	61

**Tables**

Table 1: Dimensions of Aluminium conductors, stems and pads used in Eskom.....	9
Table 2: List of Eskom Clamps.....	10
Table 3: Substation conductors.....	16
Table 4: Type tests to be performed per clamp family.....	24
Table 5: Additional Type tests to be performed per clamp family for SPACERS.....	25
Table A.1: Type EX clamps.....	30
Table A.2: Type EXC Clamps.....	31
Table A.3: Type EUT Clamps.....	32

---

Table A.4: Type ETC Clamps .....	33
Table A.5: Type EY Clamps .....	35
Table A.6: Type EYC Clamps – Bolted .....	36
Table A.7: Type EYC Clamps – 8-Hole Pad.....	37
Table A.8: Type EYC Clamps – 9-Hole Pad.....	38
Table A.9: Type EY3 Clamps .....	39
Table A.10: Type EYC3 Clamps – Bolted .....	40
Table A.11: Type EYC3 Clamps – 8-Hole Pad.....	41
Table A.12: Type EYC3 Clamps – 9-Hole Pad.....	42
Table A.13: Type EPC Clamps – 100x100mm Pad .....	43
Table A.14: Type EPC Clamps – 125x125mm Pad .....	44
Table A.15: Type EPC Clamps – Undrilled Pad .....	45
Table A.16: Type ES Spacers .....	46
Table A.17: Type ESC Spacers.....	47
Table A.18: Type EXP Clamps .....	48
Table A.19: Type EXCP Clamps .....	49
Table A.20: Type EXCP2 Clamps .....	50
Table A.21: Type EXCP3 Clamps .....	51
Table A.22: Type EYBC Clamps .....	52
Table A.23: Type EPT Clamps .....	53
Table A.24: Type EPT2 Clamps .....	54
Table A.25: Type EPTT2 Clamps .....	55
Table A.26: Type EEPC Clamps .....	56
Table A.27: Type EESP Clamps .....	57
Table A.28: Type EPISF Clamps.....	58
Table A.29: Type EYCT Clamps .....	59
Table A.30: Type EYCDT Clamps.....	60
Table A.31: Type ECJW Clamps.....	61

## **1. Introduction**

Substation clamps are critical components within a substation since they are generally connected in series with the current path. The reliability of the whole power network may be compromised by the failure of clamps if they are not properly designed, manufactured and adequately tested to operate not only under normal operating conditions, but also a range of abnormal conditions as well.

## **2. Supporting clauses**

### **2.1 Scope**

This standard covers Eskom's requirements for the design, manufacture, testing, supply and delivery of substation clamps for stranded conductors for use in outdoor high-voltage substations with maximum system voltages of up to and including 420 kV.

#### **2.1.1 Purpose**

This document gives the minimum requirements for the design, manufacture, testing, supply and delivery of substation clamps for stranded conductors that will ensure adequate performance and operation within the Eskom system.

#### **2.1.2 Applicability**

This document shall apply throughout Eskom Holdings Limited Divisions.

## **2.2 Normative/informative references**

Parties using this document shall apply the most recent edition of the documents listed in the following paragraphs.

### **2.2.1 Normative**

- [1] ANSI/NEMA CC 1: Electric power connection for substations.
- [2] ANSI C119.4: Electric connectors - Connectors to use between aluminium-to-aluminium or aluminium-to-copper conductors.
- [3] BS EN 573-2: Aluminium and aluminium alloys – Chemical composition and form of wrought products – Part 2: Chemical symbol based designation system.
- [4] BS EN 573-3: Aluminium and aluminium alloys – Chemical composition and form of wrought products – Part 3: Chemical composition and form of products.
- [5] SANS 51706 (BS EN 1706): Aluminium and aluminium alloys – Castings – Chemical composition and mechanical properties
- [6] BS EN 10002-1: Metallic materials – Tensile testing – Part 1: Method of test at ambient temperature.
- [7] CIGRE Technical Brochure 930, Review of Substation Busbar Component Reliability
- [8] CISPR 16-1: Specification for radio disturbance and immunity measuring apparatus and methods – Part 1: Radio disturbance and immunity measuring apparatus.
- [9] CISPR 18-2: Radio interference characteristics of overhead power lines and high-voltage equipment – Methods of measurement and procedure for determining limits.
- [10] IEC 60060-1, High-voltage test techniques – Part 1: General definitions and test requirements.
- [11] IEC 60273: Characteristics of indoor and outdoor post insulators for systems with nominal voltages greater than 1000 V.

**ESKOM COPYRIGHT PROTECTED**

- [12] IEC 60943: Guidance concerning the permissible temperature-rise for parts of electrical equipment, in particular for terminals.
- [13] IEC 61854: Overhead Lines – Requirements and Tests for Spacers
- [14] IEC 62271-1: High-voltage switchgear and control gear – Part 1: Common specifications
- [15] IEC 62271-301: High-voltage switchgear and control gear – Part 301: Dimensional Standardization of Terminals
- [16] ISO 9001, Quality Management Systems.
- [17] ISO 9591: Corrosion of aluminium alloys – Determination of resistance to stress corrosion cracking.
- [18] NEMA HV 80036: Methods of Measurement of Radio Influence Voltage (RIV) of High-Voltage Apparatus.
- [19] SANS 1700 (series): Fasteners.
- [20] SANS 51706: Aluminium and aluminium alloys – Castings – Chemical Composition and Mechanical Properties

**2.2.2 Informative**

- [21] 240-84512873 Technical Evaluation Standard for Substation Stranded Conductor Clamps
- [22] CIGRE Technical Brochure 207, Thermal Behaviour of Overhead Conductors
- [23] NATIONAL TREASURY DESIGNATED SECTORS CIRCULAR NUMBER 1 OF 2020/2021: Stipulated minimum threshold for local production and content for Steel Power pylons, Steel Substation Structures, Powerline Hardware, Street Lighting Steel Poles and Steel Lattice Towers and Masts.

**2.3 Definitions**

**2.3.1 General**

<b>Definition</b>	<b>Description</b>
<b>Accredited testing laboratory/authority</b>	A laboratory which is ISO/IEC 17025 accredited and/or holds valid certification issued by ILAC (International Laboratory Accreditation Corporation) or one of its members
<b>Certified test report</b>	A certificate of tests performed as specified within the standard and carried out by an accredited authority or by the manufacturer and witnessed by an accredited authority that has been accredited in accordance with ISO/IEC 17011
<b>Clamp/connector</b>	A device that joins two or more conductors for the purpose of providing a continuous electrical path
<b>Pad</b>	A solid, flat, rectangular block
<b>Pad terminal connector</b>	A connector that joins a conductor to the terminal pad of electrical apparatus
<b>Ra</b>	A measure of surface smoothness that quantifies the average deviations of a surface profile from its ideal form
<b>Routine tests</b>	Tests done to verify the quality and uniformity of the workmanship and materials used in the manufacture of electric power connectors
<b>Saddle</b>	A clamp that fastens onto a bolted clamp/connector to hold the conductor in place

Definition	Description
<b>Sample tests</b>	Tests done to verify the quality of materials and workmanship
<b>Serve spot</b>	A smooth or un-grooved area on the outer edges and ends of the grooves of conductor clamps
<b>Short-circuit current</b>	The current flowing at a given point of a network resulting from a short circuit at another point of this network
<b>Stem</b>	A solid cylindrical termination
<b>Stem terminal connector</b>	A connector that joins a conductor to the terminal stem of electrical apparatus
<b>Thread galling</b>	Thread galling occurs during installation when pressure and friction cause bolt threads to seize to the threads of a nut or tapped hole. It is also referred to as "cold welding".
<b>Type tests</b>	Tests done on the completion of the development of a new design to establish representative performance data. They need to be repeated if the design is changed to modify its performance or there is a change in the manufacturing process

### 2.3.2 Disclosure classification

**Controlled disclosure:** controlled disclosure to external parties (either enforced by law, or discretionary).

## 2.4 Abbreviations

Abbreviation	Description
<b>AAC</b>	All Aluminium Conductor
<b>AAAC</b>	All Aluminium Alloy Conductor
<b>ACSR</b>	Aluminium Conductor Steel Reinforced
<b>AMSL</b>	Above Mean Sea Level
<b>CISPR</b>	International Special Committee on Radio Interference
<b>OD</b>	Outer Diameter
<b>PCD</b>	Pitch Circle Diameter
<b>Ra</b>	Refer to contact surface smoothness
<b>RIV</b>	Radio Interference Voltage

## 2.5 Roles and responsibilities

All personnel involved within the substation environment shall ensure compliance to these requirements.

## 2.6 Process for monitoring

Not applicable.

## 2.7 Related/supporting documents

Not applicable.

### 3. Specification for Substation Clamps for Stranded Conductor

#### 3.1 General

##### 3.1.1 Service conditions

The clamps/connectors shall be suitable for use in substations under the following service conditions:-

- a) Altitude : up to 1 800 m AMSL
- b) Ambient air temperatures
  - 1) minimum : -10 °C
  - 2) maximum : 45 °C
  - 3) daily average : 30 °C
  - 4) yearly average : 20 °C
- c) Maximum solar radiation : 1 100 Watts / m<sup>2</sup>
- d) Wind speed : 0.44 m/s

##### 3.1.2 Technical information

Aluminium or aluminium alloy clamps/connectors, and conductors are required for making connections between various arrangements of stranded conductors, tubes, solid terminal stems and pads. The standard dimensions adopted by Eskom for these items are listed in Table 1 below.

The conductor 1 second ratings are derived with CIGRE TB 207 equation 41 with initial and final temperatures 40°C and 200°C respectively.

**Table 1: Dimensions of Aluminium conductors, stems and pads used in Eskom**

Type	Diameter (mm)	Remarks	1 second current rating (kA)
Stranded All Aluminium Conductors (AAC)	16.25	"Hornet"	15.7
	26.46	"Centipede"	41.4
	38.34	"Bull"	86.3
Stranded All Aluminium Alloy Conductors (AAAC)	6.24	"Acacia"	2.2
	8.31	"35"	4.0
	10.83	"Pine"	6.8
	13.95	"Oak"	11.2
	17.4	"Ash"	17.1
	22.61	"Sycamore"	28.7
	24.71	"UPAS"	34.3
Stranded Aluminium Conductor Steel Reinforced (ACSR)	7.08 - 10.98	"Gopher" to "Mink"	Gopher = 2.9; Mink = 7.0
	14.16 - 18.13	"Hare" to "Wolf"	Hare = 11.7; Wolf = 18.3
	18.87	"Chickadee"	20.8
	21.00	"Panther"	24.6
	23.45	"Bear"	30.7
	23.90	"Kingbird"	33.5
	25.97	"Goat"	37.7

**ESKOM COPYRIGHT PROTECTED**

Type	Diameter (mm)	Remarks	1 second current rating (kA)
	27.00	"Tern"	42.3
	28.62	"Zebra"	46.8
	29.59	"Rail"	50.8
	35.50	"Dinosaur"	72.1
	35.58	"Bersford"	73.1
Stems	26.0	125 long	-
	38.0	125 long	-
	60.0	125 long	-
Pads - 14mm diameter holes, - 16mm minimum pad thickness	4-bolt pad to SANS/IEC 62271-301	100 x 100 mm (50 x 50 mm hole centres)	-
	4-bolt pad (125x125)	125 x 125 mm (80 x 80 mm hole centres)	-
	8-bolt pad to SANS/IEC 62271-301	100 x 200 mm (50 x 50 mm hole centres)	-
	9-bolt pad to SANS/IEC 62271-301	125 x 125 mm (40 x 40 mm hole centres)	-

### 3.2 Clamp types, dimensions and ratings

The list of clamps that are covered by this specification is shown in Table 2 below. The table also shows the clamps that need to be tested in order to qualify a family/series of clamps.

**Table 2: List of Eskom Clamps**

Annexure A location	Clamp Type / Designation	Clamps to be tested to qualify a Family of clamps (e.g. for EX type test clamp A and E)		
Table A.1	Type EX clamps	A		E
Table A.2	Type EXC Clamps	A or L	B or F or G	P or Q or R
Table A.3	Type EUT Clamps	A	B	E
Table A.4	Type ETC Clamps	Q	L	K
Table A.5	Type EY Clamps	B or D	E or F	J
Table A.6	Type EYC Clamps – Bolted	D		S
Table A.7	Type EYC Clamps – 8-Hole Pad			
Table A.8	Type EYC Clamps – 9-Hole Pad			
Table A.9	Type EY3 Clamps	B		
Table A.10	Type EYC3 Clamps – Bolted	A		D
Table A.11	Type EYC3 Clamps – 8-Hole Pad			
Table A.12	Type EYC3 Clamps – 9-Hole Pad			
Table A.13	Type EPC Clamps – 100x100mm Pad	A		E
Table A.14	Type EPC Clamps – 125x125mm Pad			
Table A.15	Type EPC Clamps – Undrilled Pad			

**ESKOM COPYRIGHT PROTECTED**

Annexure A location	Clamp Type / Designation	Clamps to be tested to qualify a Family of clamps (e.g. for EX type test clamp A and E)		
Table A.16	Type ES Spacers	D		
Table A.17	Type ESC Spacers	A	B	D
Table A.18	Type EXP Clamps	B		
Table A.19	Type EXCP Clamps	D		
Table A.20	Type EXCP2 Clamps	D		
Table A.21	Type EXCP3 Clamps	B		
Table A.22	Type EYBC Clamps	E		
Table A.23	Type EPT Clamps	B		
Table A.24	Type EPT2 Clamps	B		
Table A.25	Type EPTT2 Clamps	B		
Table A.26	Type EEPC Clamps	A		
Table A.27	Type EESP Clamps	A		
Table A.28	Type EPISF Clamps	B		
Table A.29	Type EYCT Clamps	B		
Table A.30	Type EYCDT Clamps	B		
Table A.31	Type ECJW Clamps	A		

### 3.2.1 Type EX Clamps D-DT-6002

The EX clamp is a bolted-bolted ‘cross’ clamp and shall be such that connections can be made either in-line or at an angle of 90° at either end of the clamp. ‘A’ is intended for bolting onto a solid stem, whilst ‘B’ is intended for bolting onto stranded conductor.

EX clamps are generally only to be used in low current or non-current carrying applications e.g. through connections on support post insulators, voltage transformers and surge arresters. Each half-clamp shall be fitted with two independent clamping saddles.

Types, dimensions and ratings are shown in Table A.1. The clamp is illustrated in Figure A.1.

### 3.2.2 Type EXC Clamps D-DT-6006

These bolted-compression clamps are intended for making connections between a solid terminal stem and a stranded conductor. The bolted end is intended for bolting to a solid stem, whilst the compression end is intended for crimping onto a stranded AAC or AAAC conductor. The bolted end shall be fitted with two independent clamping saddles.

Types, dimensions and current ratings are shown in Table A.2. The clamp is illustrated in Figure A.2.

### 3.2.3 Type EUT Clamps D-DT-6099

These clamps shall be of the bolted-bolted type suitable for making “Tee” connections off a busbar or line conductor. The ‘Run’ as well as the ‘Tap’ shall be fitted with at least two independent bolted saddles. ‘EUT’ clamps should only be used in very low or non-current carrying applications.

Types, dimensions and current ratings are shown in Table A.3. The clamp is illustrated in Figure A.3.

### **3.2.4 Type ETC Clamps D-DT-6010**

These bolted "Tee"-compression clamps are intended for making connections from a stranded conductor "Run", which is under tension, onto a stranded conductor "Tee" connecting to equipment. The bolted "Run" section of these clamps shall be fitted with at least three independent clamping saddles.

Types, dimensions and ratings of ETC clamps are shown in Table A.4. The clamp is illustrated in Figure A.4.

### **3.2.5 Type EY Clamps D-DT-6022**

These clamps shall be of the bolted-bolted type designed for making a connection onto a single solid terminal stem from a pair of stranded conductors. These clamps can be used as a single tap off from a twin conductor bundle. 'A' is intended for bolting onto a solid stem, whilst 'B' is intended for bolting onto two stranded conductors. These clamps are used for both low current-carrying applications (connections on current transformers and isolators) and non-current carrying applications (connections on support post insulators, voltage transformers and surge arresters).

'EY' clamps should not be used on end connections. Two clamping saddles shall be provided for each connection.

Types, dimensions and ratings are shown in Table A.5. The clamp is illustrated in Figure A.5.

### **3.2.6 Type EYC Clamps D-DT-6013 and D-DT-6109**

These clamps shall be similar to the bolted-bolted 'EY' clamps. However, on the pair of stranded conductor side it shall be a compression type with a 0°, 45° or 90° orientation. The other side will be a bolted or a palm connection. At least two clamping saddles shall be provided for the bolted connection.

Types, dimensions and ratings are shown in:

- Table A.6 illustrated in Figure A.6: EYC Clamp – Bolted Connection,
- Table A.7 illustrated in Figure A.7: EYC Clamp – 8-Hole Pad Connection, and
- Table A.8 illustrated in Figure A.8: EYC Clamp – 9-Hole Pad Connection

### **3.2.7 Type EY3 Clamps D-DT-6007**

These clamps are intended for use in conjunction with post insulators to support phase conductor bundles between items of outdoor high voltage apparatus.

They shall be of the bolted type designed for making connections between horizontal triple conductors and a single vertical stem. Providing the clamp is applied correctly with reference to the current rating, this clamp can be used as a single tap off from a triple conductor bundle. They should, however, generally only be used for non-current carrying purposes, e.g. through connections on support post insulators, voltage transformers and surge arresters as applicable.

Types, dimensions and ratings are shown in Table A.9. The clamp is illustrated in Figure A.9.

### **3.2.8 Type EYC3 Clamps D-DT-6008**

These clamps shall be similar in design to the twin-conductor EYC clamp, except that a higher current rating is required based on three conductors per stem/pad. Clamps that are bolted onto stems, viz. EYC3-A, EYC3-C and EYC3-E, shall be of a double shell construction to facilitate lower current densities at contact interfaces.

Types, dimensions and ratings are shown in:

- Table A.10 illustrated in Figure A.10: EYC3 Bolted/Compression Clamp for Stem Connection,
- Table A.11 illustrated in Figure A.11: EYC3 Bolted/Compression Clamp for 8-Hole Pad Connection,
- Table A.12 illustrated in Figure A.12: EYC3 Bolted/Compression Clamp for 9-Hole Pad Connection,

### **3.2.9 Type EPC Clamps D-DT-6018**

Palm-compression clamps are intended for making connections from flat terminal pads onto single stranded conductors, the palm being bolted directly onto the terminal pad and the conductor end connected with a compression fitting.

Types, dimensions and ratings are shown in:

- Table A.13 illustrated in Figure A.13: EPC Clamp 100x100mm Pad,
- Table A.14 illustrated in Figure A.14: EPC Clamp 125x125mm Pad,
- Table A.15 illustrated in Figure A.15: EPC Clamp Undrilled Pad.

### **3.2.10 Type ES Spacers D-DT-6087 (Non-Current Carrying)**

Spacers are required to keep standard conductors at specified distances apart and shall be designed to withstand the forces that occur under wind and short-circuit conditions.

Types, dimensions and ratings are shown in Table A.16. The non-current carrying spacer (ES) is illustrated in Figure A.16.

### **3.2.11 Type ESC Spacers D-DT-6087 (Current Carrying)**

These spacers are required to equalise the phase conductor bundle current at drop off points from the busbars where phase dropper conductor bundles of fewer conductors per bundle are used. They are to keep standard conductors at specified distances apart and shall be designed to withstand the forces that occur under wind and short-circuit conditions.

Types, dimensions and ratings are shown in Table A.17. The spacers are illustrated in Figure A.17.

### **3.2.12 Type EXP Clamps D-DT-6027**

These bolted cross-pad clamps are intended for making connections between stranded conductors/stems and pads. These clamps should not be used as adaptors.

Types, dimensions and ratings are shown in Table A.18. The clamp is illustrated in Figure A.18.

### **3.2.13 Type EXCP Clamps D-DT-6029**

These pedestal-mounted bolted clamps are intended for making connections between stranded conductors and post insulators. All holes shall be slotted to facilitate alignment of the PCD base.

Types, dimensions and ratings are shown in Table A.19. The clamp is illustrated in Figure A.19.

### **3.2.14 Type EXCP2 Clamps D-DT-6025**

These pedestal-mounted bolted clamps are intended for supporting twin conductor bundles on post insulators. All holes shall be slotted to facilitate alignment of the PCD base.

Types, dimensions and ratings are shown in Table A.20 for details. The clamp is illustrated in Figure A.20.

### **3.2.15 Type EXCP3 Clamps (No D-DT-drawing)**

These pedestal-mounted bolted clamps are intended for supporting triple conductor bundles on post insulators. All holes shall be slotted to facilitate alignment of the PCD base.

Types, dimensions and ratings are shown in Table A.21 for details. The clamp is illustrated in Figure A.21.

### **3.2.16 Type EYBC Clamps (No D-DT-number)**

Clamps are required to equalise the phase conductor bundle current at drop off points from the busbars where phase dropper conductor bundles of fewer conductors per bundle are used. They are to keep standard conductors at specified distances apart and shall be designed to withstand the forces that occur under short-circuit conditions.

Types, dimensions and ratings are shown in Table A.22. The clamp is illustrated in Figure A.22.

### **3.2.17 Type EPT Clamps D-DT-6004**

These bolted-type clamps shall be used mainly for connecting single stranded conductors to earth switches with 4-hole pad terminals.

Types, dimensions and ratings are shown in Table A.23. The clamp is illustrated in Figure A.23.

### **3.2.18 Type EPT2 Clamps D-DT-6005**

These bolted-type clamps shall be used mainly for connecting twin stranded conductor bundles to earth switches with 8-hole pad terminals.

Types, dimensions and ratings are shown in Table A.24. The clamp is illustrated in Figure A.24.

### **3.2.19 Type EPTT2 Clamps D-DT-6371**

These "twisted" bolted-type clamps shall be used mainly for connecting twin stranded conductor bundles to earth switches with 8-hole pad terminals.

Types, dimensions and ratings are shown in Table A.25. The clamp is illustrated in Figure A.25.

### **3.2.20 Type EEPC Clamps D-DT-6115**

EEPC clamps are used for connecting portable earthing to stranded conductors.

Types, dimensions and ratings are shown in Table A.26. The clamp is illustrated in Figure A.26.

### **3.2.21 Type EESP Clamps D-DT-6003**

EESP clamps are used for connecting a stem to a palm connection on equipment.

Types, dimensions and ratings are shown in Table A.27. The clamp is illustrated in Figure 27.

### **3.2.22 Type EPISF Clamps (No D-DT-number)**

These post insulator stem fittings are used to provide for clamp connections on post insulators where needed.

Types, dimensions and ratings are shown in Table A.28. The clamp is illustrated in Figure A.28.

### **3.2.23 Type EYCT Clamps D-DT-6011**

These twisted "Y" compression terminal clamps are intended to be used on inline (also referred to as transverse) isolators and earth switches.

Types, dimensions and ratings are shown in Table A.29. The clamp is illustrated in Figure A.29.

### **3.2.24 Type EYCDT Clamps D-DT-6012**

These twisted double "Y" compression terminal clamps are intended to be used on inline (also referred to as transverse) isolators and earth switches.

Types, dimensions and ratings are shown in Table A.30. The clamp is illustrated in Figure A.30.

### **3.2.25 Type ECJW Clamps D-DT-6014**

These conductor jumper weights are intended to be used on jumper conductors to minimise conductor swing. It is important to note that these conductor weights must be installed around the conductor to ensure that it does not negatively impact clearances or contribute to corona, and for this reason it is important that the indicated maximum dimensions are adhered to. It might be necessary to manufacture these jumper weights from lead taking into consideration the required weight and maximum dimensions indicated.

Types, dimensions and ratings are shown in Table A.31. The clamp is illustrated in Figure A.31.

## **3.3 Technical Requirements**

### **3.3.1 Materials**

All clamps, excluding jumper conductor weights (ECJW clamps), shall be made from aluminium or aluminium alloys. The alloy used, its chemical composition, electrical and mechanical properties shall be in accordance with SANS 51706. The alloys and its chemical composition shall be stated in Technical Schedule B. The alloy must not contain more than 0,1% Cu and shall not be prone to stress corrosion, cracking or layer corrosion in accordance with the requirements of ISO 9591. The manufacturing method (e.g. cast or wrought) and the alloy shall fulfil the requirements relating to tensile strength, hardness and conductivity. The clamp materials shall be resistant to atmospheric corrosion.

Considering the dimension limitations and weight requirements of the jumper conductor weights (ECJW clamps) it might be necessary to manufacture these from lead.

### **3.3.2 Machining**

- a) The contact areas of all clamps used for current-carrying purposes that interface with solid cylindrical conductors e.g. aluminium tubes or stems, are to be machined to create true cylindrical surfaces. These surfaces shall be smooth machined with an average roughness (Ra) ranging from 1,6 to 2.
- b) The contact surfaces of the current-carrying ends of the clamp, that bolt onto stranded conductor, shall be grooved, with each end of the groove equipped with a so called 'serve spot' to allow easy embedding of the served stranded conductor. It is left to the manufacturer to provide specially designed grooves or ridges on the contact surface. The performance of the clamp design shall be confirmed and supported with the relevant type tests. The damage caused to the conductor by the clamps e.g. by grooves that cut into the conductor, shall be such that the conductor strength is not reduced to less than 90 % of the ultimate strength, nor shall the electrical conductance be impaired.
- c) Pads are to be serrated-machined to guarantee the best connection and current transfer. If a manufacturer proposes a deviation from this requirement, such a deviation shall be supported, confirmed and verified with the appropriate type tests and a guarantee of the performance of the design.

### **3.3.3 Bolted connections**

All bolted clamps shall be equipped with at least two or more independent saddles in accordance with the requirements specified.

To prevent thread galling of nuts and bolts an anti-seize lubricant must be applied, i.e. molybdenum disulfide paste or equivalent.

#### **3.3.3.1 Bolts**

Clamping bolts shall comply with the requirements of SANS 1700, have hexagonal heads and shall be made from hot-dip galvanized steel (minimum grade 4.6) unless otherwise specified. Bolts shall have a minimum tensile strength of 480 MPa in accordance with NEMA CC 1.

Bolts shall be of a quality that enables the required torque levels to be achieved without compromising the clamp contact surface pressure. The specific mounting force shall not be less than 120 N per transmitted ampere in the case of stranded conductors.

No bolt shall have a diameter of less than 10 mm unless otherwise approved by Eskom. The design torque that is to be applied to the bolts for optimum performance shall be stated in Technical Schedule B, together with the minimum torque at which operation is guaranteed.

After the bolts have been tightened, the gap between the saddle and the clamp body shall be not less than 2 mm.

The maximum tightening torque on bolts shall be in accordance with the following:

- not exceed 75 Nm;
- not exceed 50 % of the value at which fracture of permanent distortion of the bolts, or fracture of the clamp, occurs. Bolt fracture shall occur before the threads strip; and
- the maximum specific surface pressure under flat washers shall not exceed 120 N/mm<sup>2</sup>.

### 3.3.3.2 Nuts

Nuts shall comply with the requirements of SANS 1700.

Nuts shall be made of the same material as the bolts, hot-dip galvanized steel (minimum grade 4.6).

Nuts shall be resistant to corrosion.

### 3.3.3.3 Washers

Only flat plain washers shall be used and comply with the requirements of SANS 1700.

Flat washers shall be made of hot-dip galvanized steel (grade A) and shall be resistant to corrosion.

Flat washer/bolt size combinations shall be according to ANSI/NEMA CC 1.

Flat washers shall be provided under the bolt head only if the bolt head is free to move and captive nuts are provided. Alternatively, if captive bolts are provided, and the nuts are free to move, flat washers shall be provided under the nut. Spring washers are not required.

### 3.3.4 Compression connections

A compression clamp shall be any conductor clamp requiring a compression tool capable of exerting a compressive force sufficient to deform the clamp sleeve and all layers of the conductor so that an electrical and mechanical joint is achieved.

The compression sleeves shall be manufactured from extruded tubing having bore sizes to suit conductors as is shown in Table 3. The type of tubing, alloy and dimensions used shall be stated in Schedule B.

The supplier shall ensure that the sleeve tubing is dimensioned and manufactured properly, taking into consideration the diameter range of the corresponding conductor in Table 1. The sleeve shall be designed in such a way that the conductor shall fit into the tubing with ease and still not compromise the integrity of the entire connection.

**Table 3: Substation conductors**

Conductor type	Conductor cross-sectional area (mm <sup>2</sup> )	Conductor diameter (mm)	
		Minimum	Maximum
Hornet	150	16,25	16,42
Centipede	400	26,46	26,73
Bull	800	38,34	38,73

The recommended compression force and the number of compressions per joint shall be stated in Technical Schedule B.

If line boring, or drilling techniques are used in the manufacture of the sleeves, the tolerance on the wall thickness shall not exceed 5%.

All compression clamp sleeves shall be pre-greased, and the conductor opening shall have a dust cap applied. The grease shall be applied to cover the entire inner tubing of the sleeve. The type of grease used shall be specified in Technical Schedule B.

Compression clamp sleeves shall have a drilled hole with a diameter of 4mm that will serve as a passage for the flow of excess grease during compression.

The compression sleeves are required to be marked externally with the position, the number of compressions required and the across flats dimension. The die size shall also be marked on the compression sleeve.

The compression tool and its head and dies shall be stated in Technical Schedule B. Dies shall be made of corrosive resistant material with a high resistance to wear and the die identification shall be embossed on the sleeve after compression. All dies shall be provided with test gauges that will pass through the associated die when excessive wear has occurred. Details of the compression tool can be found in the 240-82736997.

Each set of tools shall be supplied with a manual, describing the method of operation and detailing maintenance requirements.

### **3.3.5 Welded connections**

All welds shall be of a quality and type that will ensure "fusing" between the materials involved. Welding shall be done using either a tungsten inert-gas-shielded arc or metal inert gas-shielded arc process. Welding jigs shall be used to ensure the correct alignment of sleeves. Welds shall be clean, sound, smooth, uniform without overlaps, properly fused and completely sealed. There shall be no cracks, voids, incomplete penetration, incomplete fusion, undercutting or inclusions. Porosity shall be minimised so as not to affect the mechanical properties of the aluminium alloys. Welds shall be performed by accredited welding personnel and the welding procedure shall be subject to Eskom's approval.

### **3.3.6 Pad connections**

Pad terminals shall fit terminals as per SANS/IEC 62271-301 and shall be dimensioned in accordance with ANSI NEMA CC 1 as listed below.

- 4-hole pad: Table D-2 (Country = Germany)
- 8-hole pad: Table D-3 (Country = Germany)
- 9-hole pad: Table D-4 (Country = Sweden)

The number of holes required shall be shown on the sample drawings of the relevant clamps in Annexure A and specified in Technical Schedule A.

All pad terminals shall be serrated-machined to guarantee the best connection and current transfer.

### **3.3.7 PCD terminals**

All insulator support clamps with PCD terminals shall have slotted holes. The slotted holes shall have the following dimension:

- 76mm PCD: Ø14x21mm Long
- 127mm PCD: Ø18x27mm Long
- 225mm PCD: Ø18x27mm Long

### **3.3.8 Electrical joint compound**

In order to minimise contact resistance due to oxidation of the aluminium surfaces, a recommendation shall be submitted regarding the cleaning treatment to be adopted, the type of compound to be used, and its properties, including the following:-

**ESKOM COPYRIGHT PROTECTED**

- temperature rating, particularly under short-circuit conditions, degree of adhesion,
- performance in wet or salt-water conditions,
- suitability for use in bolted and / or compression clamps,
- need for replenishment and expected life span,
- availability and sources of supply.

The compound shall not attack the aluminium material.

The compound shall not cause corona.

The drop point of the compound shall be  $>90$  °C.

The flash point of the compound shall be  $\geq 140$  °C.

The oil separation of the compound shall be  $\leq 1\%$  at  $100^{\circ}\text{C}$  for 4 hours.

### **3.3.9 Spacers**

Spacers shall be designed to meet all the requirements of IEC 61854.

### **3.3.10 Rated continuous current**

The rated continuous current of each clamp shall be in accordance with the value stated in the relevant table of this specification.

The clamps and connectors shall be capable of carrying continuously the current specified without exceeding a temperature rise of  $45^{\circ}\text{C}$  above an ambient temperature of  $45^{\circ}\text{C}$ .

When a connection is made between two conductors of different sizes, the current rating of the current-carrying clamps used shall not be less than that of the lowest rated conductor.

### **3.3.11 Rated short-circuit withstand current**

Refer to tables in Annex A for the requirements applicable to the various clamps.

Where different sizes of conductors are interconnected by a clamp, the clamp rated short-circuit withstand current shall be equal to the rated short-circuit current of the smallest conductor connected.

### **3.3.12 Maximum Operating Temperature**

Under normal operating conditions, clamps shall be capable of carrying continuously the rated normal current specified without exceeding the maximum allowable operating temperature of  $45^{\circ}\text{C}$  above an ambient temperature of  $45^{\circ}\text{C}$ .

The temperature rise of a clamp shall not exceed the temperature rise of the conductor to which it is connected.

Where different sizes of conductors are interconnected by a clamp, the temperature rise of the clamp shall not exceed the temperature rise of the conductor having the highest temperature rise.

Under short-circuit conditions; the clamp temperature rise shall not exceed  $200$  °C.

### **3.3.13 Corona performance**

All clamp/connector assemblies shall be capable of operating at the stipulated voltages ( $U_m$ ) without any signs of visible corona, at altitudes of up to and including  $1800$  m.

All clamps shall be corona free on their own (without the application of corona rings) up to the voltage specified. Clamps with a specified  $U_m > 420$  kV shall be corona free on their own up to and including  $420$  kV, and up to the specified voltage with the aid of a corona ring.

### 3.3.14 Mechanical Strength

Clamps shall be designed in such a way that they are capable of withstanding mechanical forces to which they may be subjected in service, including those due to short-circuits and wind loading, without failure or damage.

## 3.4 Tests

The tests are classified as type tests, sample tests and routine tests.

All type tests shall be done by an independent testing laboratory or witnessed by an accredited, independent testing authority if done in-house. All test reports shall be in English.

### 3.4.1 Type Tests (Clamps)

A series of type tests to evaluate performance of the conductor clamps are specified below. These tests are divided into two categories, viz. electrical and mechanical type tests. Some of these tests can be combined as part of the electrical tests since severe shock forces are exerted on the clamps in the case of short-circuit tests.

If the clamps/connectors offered have been tested for compliance with an internationally accepted specification, such test reports may be accepted by Eskom in lieu of the tests covered by this specification. Tenderers are requested to indicate if they comply with such tests at the tendering stage and shall submit these with their tender for Eskom's consideration.

A family of clamps is a group of clamps using similar design criteria. In order to qualify a family of clamps (for a specific type of clamp), all the relevant clamps as specified by Eskom in Table 2 shall be tested. The clamps to be tested are also indicated at the end of each table in Annexure A.

For all design and type tests, a minimum of three (3) identical clamps shall be tested and none of these clamps shall fail during a test. The design and type test shall be repeated when there is a change in the design or manufacturing process of a clamp.

Example: in order to qualify the EX-family of clamps, the tests shall be performed on three (3) EX-A and three (3) EX-E clamps.

Extrapolation of **mechanical tests** shall be allowed across a family of clamps if it is proven that the construction and type of connection is the same.

Extrapolation of **electrical tests** shall be allowed:

- within a family of clamps;
- across a family of clamps if it is proven that the construction and type of connection is the same.

The following rule shall apply: Extrapolation shall be allowed downwards only, i.e. the highest rated clamps test results may be used to extrapolate downwards to a lower rated clamp where the construction and type of connection is the same.

Extrapolated test results might have an influence on qualifying a family of clamps and will be reviewed on a case-by-case base, since it deviates from the specified clamps required to be tested in Table 2.

The onus is on the manufacturer to prove that the design is technically similar and that it complies with the rules for extrapolation.

Eskom reserves the right to request or witness any or all of the specified tests. Should Eskom exercise its right to witness testing, its employees and/or appointed representatives shall be given access and permission to the test facility.

#### 3.4.1.1 Heat (current)-cycle test

Heat (current)-cycle tests shall be conducted using the light duty cycle (N = 125 cycles) in accordance with the relevant test procedure and requirements of ANSI C119.4.

#### **3.4.1.2 Temperature rise test**

Temperature rise tests shall be conducted in accordance with the relevant test procedure and requirements of ANSI/NEMA CC 1, with the exception that the rated current of the clamps shall be as stated in this specification.

#### **3.4.1.3 Corona and RIV test**

Corona tests shall be performed according to the test procedure and requirements of ANSI/NEMA CC 1 or IEC 61284.

RIV tests shall be performed according to the test and requirements of CISPR 16-1 and CISPR 18-2 or NEMA CC 1.

The test voltage for radio influence voltage shall be  $1,1U_m/\sqrt{3}$ , where  $U_m$  is the maximum system voltage.

Tests should be done for altitudes up to 1800 m, correction factors shall be applied in accordance with IEC 60060-1.

#### **3.4.1.4 Short-circuit withstand test**

Short-circuit withstand tests shall be conducted in accordance with the test procedure and requirements of IEC 62271-1.

#### **3.4.1.5 Bolt tightening torque test**

The bolt tightening torque test shall be performed according to the test procedure and requirements of ANSI/NEMA CC1.

#### **3.4.1.6 Slip/pull-out strength test**

The slip/pull-out strength test shall be performed according to the relevant test procedure and requirements of ANSI/NEMA CC 1.

#### **3.4.1.7 Cantilever strength of bus supports test**

The cantilever strength of bus support test shall be performed according to the relevant test procedure and requirements of ANSI/NEMA CC1.

### **3.4.2 Type Tests Acceptance Criteria (Clamps)**

#### **3.4.2.1 Heat (current)-cycle test**

The resistance of the clamp shall be stable between the twenty-fifth (25<sup>th</sup>) cycle and the completion of the number of current cycles required (N). The number of cycles (N) is specified in ANSI C119.4. Stability is when any resistance measurement does not vary by more than 5% from the average of all the measurements at specified intervals during the test.

The temperature of the clamp shall, measured at the intervals specified in ANSI C119.4, shall not exceed that of the reference conductor.

The average resistance of the joint over the last 0,5 N cycles shall not exceed the initial resistance of the joint by more than 50 %.

#### **3.4.2.2 Temperature rise test**

The temperature rise of an electric power connector at rated current shall not exceed the temperature rise of the conductor with which it is intended to be used. The temperature of the clamps shall be at least 2°C lower than that of the control conductor.

The temperature-rise of a clamp in a test shall not exceed 45 °C above an ambient temperature of 45 °C.

The temperature rise of an electric power connector that connects conductors of varying sizes shall not exceed the temperature rise of the conductor having the highest temperature rise.

#### **3.4.2.3 Corona and RIV test**

There shall be no sign of visible corona below the test voltage required for minimum corona extinction.

The clamp shall be considered to have passed the test if the radio interference voltage level at  $1,1U_m/\sqrt{3}$  does not exceed 200  $\mu$ V as per ANSI/NEMA CC 1.

#### **3.4.2.4 Short-circuit withstand test**

Clamps shall be capable of withstanding short-circuit currents without any mechanical damage or overheating. The short-circuit current withstand ratings are given in the respective clamp tables in Annex A.

Under short-circuit conditions the clamp temperature shall not exceed 200°C.

The clamps are specified for service at altitudes of up to 1800 m. If a clamp is tested at an altitude below 1800 m, the limits of operating temperature under normal and short-circuit conditions should be reduced by 2,5 % for each 500 m that the altitude specified exceeds 1000 m.

#### **3.4.2.5 Bolt tightening torque test**

There shall be no evidence of mechanical damage to all the clamp components and the conductor after the test.

#### **3.4.2.6 Slip/pull-out strength test**

The test shall be considered successful if:

- a) the clamp does not suffer any mechanical damage,
- b) the clamp's mechanical strength should not be reduced to below 90%.
- c) the connected conductor does not pull out of the clamp.

#### **3.4.2.7 Cantilever strength of bus supports test**

There shall be no evidence of mechanical damage to all the clamp components and the conductor after the test.

### **3.4.3 Type Tests (Spacers)**

#### **3.4.3.1 Corona and RIV test**

Corona tests shall be done according to the test procedure and requirements of ANSI/NEMA CC1 or IEC 61284.

RIV tests shall be performed according to the test procedure and requirements of CISPR 16-1 and CISPR 18-2 or NEMA 107.

#### **3.4.3.2 Clamp slip test**

##### **3.4.3.2.1 Longitudinal slip test**

Longitudinal slip tests shall be done according to the relevant procedure of IEC 61854.

##### **3.4.3.2.2 Torsional slip test**

Torsional slip tests shall be done according to the relevant procedure of IEC 61854.

#### **3.4.3.3 Breakaway bolt test**

Breakaway bolt tests shall be done according to the relevant procedure of IEC 61854.

#### **3.4.3.4 Clamp bolt tightening test**

Clamp bolt tightening tests shall be done according to the relevant procedure of IEC 61854.

#### **3.4.3.5 Simulated short-circuit current test**

Simulated short-circuit current tests shall be done according to the relevant procedure of IEC 61854.

#### **3.4.3.6 Compression and tension test**

Compression and tension tests shall be done according to the relevant procedure of IEC 61854.

### **3.4.4 Type Test Acceptance Criteria (Spacers)**

#### **3.4.4.1 Corona and RIV test**

There shall be no sign of visible corona below the test voltage required for minimum corona extinction.

The clamp shall be considered to have passed the test if the radio interference voltage level at  $1,1U_m/\sqrt{3}$  does not exceed 200  $\mu V$  as per ANSI/NEMA CC 1.

#### **3.4.4.2 Clamp slip test**

##### **3.4.4.2.1 Longitudinal slip test**

No slippage shall occur at or below the minimum specified value.

##### **3.4.4.2.2 Torsional slip test**

No slippage shall occur at or below the minimum specified value.

#### **3.4.4.3 Breakaway bolt test**

The bolt shall not be damaged or broken at the end of the test.

#### **3.4.4.4 Clamp bolt tightening test**

The bolt shall not be broken or damaged. The threads shall not suffer any damage.

#### **3.4.4.5 Simulated short-circuit current test**

There shall be no damage that will result in the spacer not maintaining the bundle design spacing.

#### **3.4.4.6 Compression and tension test**

There shall be no damage that will result in the spacer not maintaining the bundle design spacing after the test.

### **3.4.5 Sample Tests (Clamps)**

The following sample tests shall be conducted according to the relevant procedures of IEC 61854.

- a) Visual examination
- b) Verification of dimensions and material
- c) Slip/Pull-out strength test
- d) Clamp bolt tightening test

**ESKOM COPYRIGHT PROTECTED**

### **3.4.6 Sample Tests (Spacers)**

The following sample tests shall be conducted according to the relevant procedures of IEC 61854.

- a) Visual examination
- b) Verification of dimensions, material and mass
- c) Breakaway bolt test
- d) Clamp bolt tightening test

### **3.4.7 Routine Tests (Clamps)**

Routine tests in accordance with the manufacturer's standards shall be carried out at the works and shall include a dimensional check of each type of connector on a 1 % sample basis. Eskom reserves the right to inspect and check the equipment at any stage during or after manufacturing, and to witness any of the routine tests.

#### **3.4.7.1 Drift test**

Every batch of tubes used in the manufacture of sleeves shall be drift tested. The test shall be performed by expanding the sample, using a drift cone of suitable angle, until the increase in outside diameter of the tube exceeds 25 % or until splitting of the sample occurs, whichever occurs first. If any test piece splits before 125% of the outside tube diameter is reached, the relevant length of tube shall be scrapped.

#### **3.4.7.2 Verification of dimensions, material and mass**

Verification of dimensions shall be undertaken to ensure that clamps are within the specified material properties, dimensions and dimensional tolerances. The mass and dimensions of the clamps shall also be checked against the manufacturer's drawings to confirm compliance.

#### **3.4.7.3 Visual examination**

Visual examination shall be undertaken to ensure conformity of manufacturing process, shape and surface finish of the clamps with the contract drawings.

The quality of the welds shall be checked for integrity and consistency.

For corona-free clamps, visual inspection shall include comparison of the surface finish of sampled clamps with those clamps that passed corona tests.

### **3.4.8 Routine Tests (Spacers)**

The following routine tests shall be conducted according to the relevant procedures of IEC 61854.

- a) Visual examination
- b) Verification of dimensions, material and mass

### **3.4.9 Tests required per clamp family**

Type tests listed in Table 4 shall be performed per clamp family. Clamps per family to be tested are listed in Table 2.

**Table 4: Type tests to be performed per clamp family**

Annexure A location	Clamp Type / Designation	Heat/current-cycle	Temperature-rise	Corona & RIV	Short-circuit withstand	Bolt tightening torque	Slip/pull-out strength	Cantilever strength
Table A.1	Type EX clamps	X	X	X	X	X	X	
Table A.2	Type EXC Clamps	X	X	X	X	X	X	
Table A.3	Type EUT Clamps	X	X		X	X	X	
Table A.4	Type ETC Clamps	X	X	X	X	X	X	
Table A.5	Type EY Clamps	X	X	X	X	X	X	
Table A.6	Type EYC Clamps – Bolted	X	X	X	X	X	X	
Table A.7	Type EYC Clamps – 8-Hole Pad	X	X	X	X		X	
Table A.8	Type EYC Clamps – 9-Hole Pad	X	X	X	X		X	
Table A.9	Type EY3 Clamps	X	X	X	X	X	X	
Table A.10	Type EYC3 Clamps – Bolted	X	X	X	X	X	X	
Table A.11	Type EYC3 Clamps – 8-Hole Pad	X	X	X	X		X	
Table A.12	Type EYC3 Clamps – 9-Hole Pad	X	X	X	X		X	
Table A.13	Type EPC Clamps – 100x100mm Pad	X	X	X	X		X	
Table A.14	Type EPC Clamps – 125x125mm Pad	X	X	X	X		X	
Table A.15	Type EPC Clamps – Undrilled Pad	X	X	X	X		X	
Table A.16	Type ES Spacers			X		X	X	
Table A.17	Type ESC Spacers	X	X	X	X	X	X	
Table A.18	Type EXP Clamps	X	X	X	X	X	X	
Table A.19	Type EXCP Clamps			X		X	X	X
Table A.20	Type EXCP2 Clamps			X		X	X	X
Table A.21	Type EXCP3 Clamps			X		X	X	X
Table A.22	Type EYBC Clamps	X	X	X	X	X	X	
Table A.23	Type EPT Clamps	X	X	X	X	X	X	X
Table A.24	Type EPT2 Clamps	X	X	X	X	X	X	X
Table A.25	Type EPTT2 Clamps	X	X	X	X	X	X	X
Table A.26	Type EEPK Clamps			X	X	X	X	
Table A.27	Type EESP Clamps	X	X	X	X			X
Table A.28	Type EPISF Clamps			X				X
Table A.29	Type EYCT Clamps	X	X	X	X		X	
Table A.30	Type EYCDT Clamps	X	X	X	X		X	
Table A.31	Type ECJW Clamps			X		X	X	

**Table 5: Additional Type tests to be performed per clamp family for SPACERS**

Annexure A location	Clamp Type / Designation	Clamp Slip Test - Longitudinal	Clamp Slip Test - Torsional	Compression and Tension Test
Table A.16	Type ES Spacers	X	X	X
Table A.17	Type ESC Spacers	X	X	X

**3.4.10 Type Test Certificates and Reports**

Copies of all type-test reports and certificates shall be submitted to Eskom in electronic format at the tender stage. Copies of sample and routine test reports shall be submitted to Eskom on request. The contractor shall retain copies of sample and routine test reports for a period of at least 2 years.

Type test reports and certificates will be acceptable as long as the clamp’s design, material composition and manufacturing process stay unchanged. Should any of these change the applicable clamp or family of clamps shall be retested.

Type test reports shall contain, as a minimum, the following information:

- Name and address of test facility.
- Contact details of test facility.
- Details and validity of accreditation of test facility.
- Date of test.
- Type of clamp tested.
- Description of the test equipment used, including test equipment serial number and last date of calibration.
- Description of test set-up, including photographs of the set-up.
- Description of test procedure.
- Test results.
- Analysis of test results.
- A statement that the clamp conforms, or does not conform, to the requirements of this specification.
- Description of the condition of the clamp after testing (include picture of the clamp).
- Names and titles of personnel who conducted the test.

**3.5 Drawings**

Drawings shall comply with the requirements stated in the relevant conditions of contract or order. The following drawings shall be submitted for approval:

- Outline dimensioned drawing for each type of connector/clamp.
- Outline dimensioned drawings for all compression tools, where applicable.

**3.6 Identification Marking**

Clamps shall be clearly and indelibly marked with the following minimum information:

**ESKOM COPYRIGHT PROTECTED**

- a) Manufacturer's identification.
- b) Eskom clamp code number.
- c) Nominal size or range of sizes of conductors with which the clamp is intended to be used.

### **3.7 Inspection of Samples**

A list of samples of clamps to be submitted during tendering shall be included in the tender enquiry documents.

### **3.8 Packaging**

All individual clamps shall be packaged in a sealed, watertight, durable, UV stabilised see-through environmentally conscious package. The clamps/connectors shall be packed in such a manner that they are adequately protected to avoid damage during transportation and storage.

To facilitate inspection and handling, the sealed clamps shall be supplied in strong durable containers. Wooden crates shall be treated.

A suitable metal label bearing the Eskom's order and item number, the quantity and the delivery address shall be securely attached to the container. The markings on the label shall not be destroyed during storage and transport.

Each crate shall be clearly marked in order to identify each crate as belonging to a specific clamp. Each container/crate shall be clearly marked with a durable label using an indelible font indicating the following information:

- Eskom order number;
- Eskom SAP number;
- Eskom clamp designation/code;
- Manufacturer's name;
- Contents of the container/crate (i.e. a parts list);
- Overall dimensions of container/crate(in mm); and
- Total mass of each crate (e.g. "TOTAL MASS: 50 KG");
- Pictograms / symbols showing correct storage and stacking instructions for crates.

### **3.9 Off-loading and Storage Procedure**

The procedure shall stipulate the maximum recommended period of storage, as well as recommended actions to be taken if a longer storage period is required.

The supplier shall contact the relevant personnel for delivery of clamp consignment at least one (1) week before delivery.

At the time of off-loading at an Eskom facility, the supplier shall ensure that clamps are off-loaded properly and safely.

### **3.10 Installation**

The supplier shall submit relevant installation procedures for clamps and spacers to Eskom at the tender stage.

### **3.11 Inspections**

The supplier shall supply inspection information in the form of manuals to Eskom at the tender stage. The manuals shall cover, amongst others, the following aspects:

- a) Frequency of inspections

**ESKOM COPYRIGHT PROTECTED**

- b) Scope of inspection
- c) Parameters to be inspected
- d) Inspection tools
- e) Inspection procedure
- f) Remedial actions

### **3.12 Documentation**

The manufacturer shall submit the following documentation with the tender:

- a) A completed technical schedule B for each clamp type. The technical schedule B shall not be left blank. Where numerical values (for example, rated values and dimensions) or specific information is required, the actual value/information shall be stated. In such cases, use of words, such as “COMPLY”, “TBA”, is not acceptable
- b) A full set of drawings
- c) A list and copies of all type test certificates and reports specified in the specification
- d) Manual(s) for handling, storage, installation and inspections
- e) Welding procedure
- f) Proof of accreditation of welder

## **4. Authorization**

This document has been seen and accepted by:

<b>Name and surname</b>	<b>Designation</b>
Subhas Maharaj	NTCSA, Senior Manager, Substation Engineering
Thomas Jacobs	Distribution, Senior Manager, Technology & Engineering (Acting)
Baldwin Maudu	Distribution, Network Engineering & Design Manager – Limpopo
Cyril Danisa	Distribution, Network Engineering & Design Manager – KwaZulu Natal
Marumo Marumo	Distribution, Network Engineering & Design Manager – Mpumalanga (Acting)
Mohau Mapane	Distribution, Network Engineering & Design Manager – North West
Roshan Pillay	Distribution, Network Engineering & Design Manager – Free State
Stephen Nkwane	Distribution, Network Engineering & Design Manager – Gauteng
Tatolo Ramoolla	Distribution, Network Engineering & Design Manager – Northern Cape
Vikesh Bhikha	Distribution, Network Engineering & Design Manager – Western Cape
Zwelitsha Magugwana	Distribution, Network Engineering & Design Manager – Eastern Cape
Derrick Delly	NTCSA, Chief Engineer, Substation Engineering
Enderani Naicker	NTCSA, Chief Engineer, Substation Engineering
Mark Peffer	NTCSA, Chief Engineer, Substation Engineering
Nkululeko Mazibuko	NTCSA, Chief Engineer, Substation Engineering
Percy Seboco	NTCSA, Chief Technologist, Substation Engineering
Rukesh Ramnarain	NTCSA, Chief Engineer, Substation Engineering

Name and surname	Designation
Shaphan Chelliah	NTCSA, Chief Engineer, Substation Engineering
Shivern Singh	NTCSA, Chief Engineer, Substation Engineering
Sipho Zulu	NTCSA, Chief Engineer, Substation Engineering
Sydney Mukhawane	NTCSA, Chief Technologist, Substation Engineering
Trevino Moonsamy	NTCSA, Chief Engineer, Substation Engineering

## 5. Revisions

Date	Rev	Compiler	Remarks
Oct 2025	2	Jason Blaauw	<p>Updated: Normative references, Informative references, Definitions, Abbreviations.</p> <p>Table 1 updated.</p> <p>3.3.2, Machining, updated.</p> <p>Technical requirements aligned with the Tubular clamp specification: sections 3.3.6, 3.3.11, 3.3.12 and 3.3.14 added.</p> <p>Tables 4 and 5 added.</p> <p>3.8, Packaging, requirements updated.</p> <p>Clamp 1s short-circuit withstand current ratings updated where applicable.</p> <p>Items added:</p> <p style="padding-left: 20px;">Table A.4: ETC-AF, ETC-AG, ETC-AH, ETC-AJ, ETC-AK</p> <p style="padding-left: 20px;">Table A.5: EY-K</p> <p>Figure A.4 updated.</p> <p>Annex C added</p>
Feb 2017	1	Jason Blaauw	<p>Specification put into new format with new number.</p> <p>Test specifications and references reviewed and updated.</p> <p>Short-Time overcurrent Pulse Test removed.</p> <p>Tensile Test removed.</p> <p>MDFL Test removed.</p> <p>Definition for pads, and serve spot added</p> <p>3.3.3 Corrected material grades for bolts, nuts and washers.</p> <p>3.3.6 Added section on PCD terminals.</p> <p>3.3.9 Amended section “The clamps and connectors shall be capable of carrying continuously the current specified without exceeding a temperature rise of 45°C above an ambient temperature of 45°C”</p> <p>3.4 Added section on Family of Clamps and Extrapolation rules</p> <p>3.4.2.7 Added section: Cantilever strength of bus supports</p>

**ESKOM COPYRIGHT PROTECTED**

Date	Rev	Compiler	Remarks
			Short-circuit ratings added to all clamp tables New clamps added: EXCP2, EXCP3, EPTT2, EPISF, EYCT, EYCDT, and ECJW.
July 2012	1	NP Tlhatlhetji	Consolidated and standardised specification for use across Eskom. This document supersedes DSP34-1974 and TSP41-726. Document published as ESP474-218.

## 6. Development team

The following people were involved in the development of the original document:

- Braam Groenewald Corporate Consultant (Substations) – Technology
- Faria Essopp Senior Engineer – Technology
- Ian Hill Senior Technologist – Technology
- Mohamed Khan Senior Engineer – KZN Operating Unit
- Phineas Tlhatlhetji Chief Engineer – Technology
- Rob Stephen General Manager – Master Specialist (Technology)
- Thandiwe Nkambule Senior Engineer – Technology

## 7. Acknowledgements

The following people were involved in updating revision 1 of the standard:

- Jason Blaauw Senior Engineer: Dx Eastern Cape OU – Standards Implementation
- Theunus Marais Chief Engineer: Dx Substation Engineering

**Annex A – Clamp Types, sample drawings, dimensions and ratings**

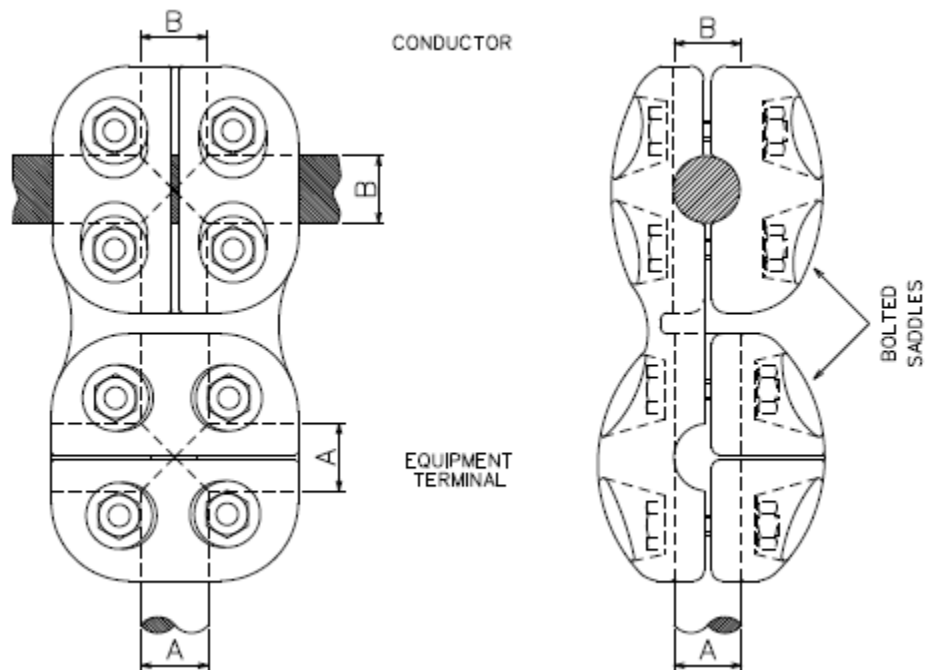

**Figure A.1: EX clamps**

**Table A.1: Type EX clamps**

Type Designation	Equipment Terminal "A" (mm)	Conductor Diameter "B" (mm)	Normal Rated Current @ 90°C [A rms]	Maximum Voltage (Um) [kV rms]	1s Short-Circuit Current Withstand Rating [kA rms]
EX-A	26	16.3	500	145	15.7
EX-B	26	26.5	900	300	40.0
EX-C	38	16.3	500	145	15.7
EX-D	38	26.5	900	300	40.0
EX-E	38	38.3	1350	420	40.0
EX-F	38	19.0	600	300	20.8
EX-G	35	26.5	900	300	40.0
EX-H	35	38.3	950	420	40.0
EX-J	26	19.0	600	300	20.8
EX-K	26	21.0	650	300	24.6

The following clamps shall be tested in accordance with section 3 of this standard:

- EX-A
- EX-E

**ESKOM COPYRIGHT PROTECTED**

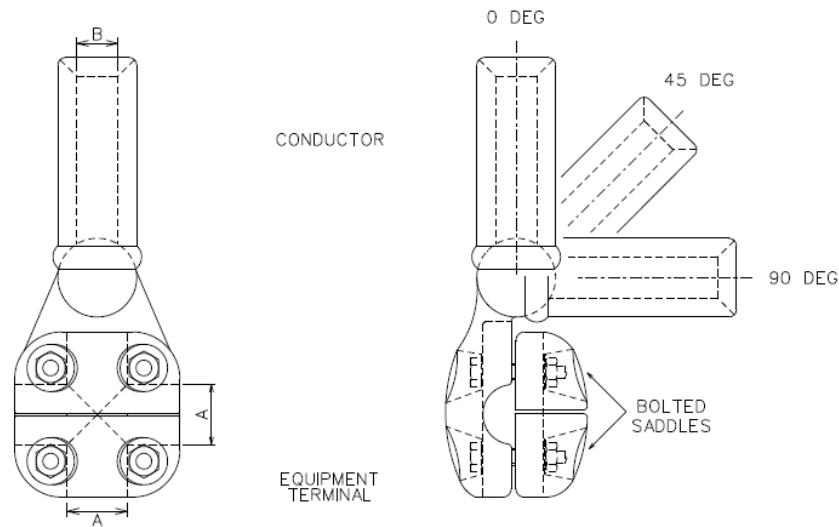

Figure A.2: EXC clamp

Table A.2: Type EXC Clamps

Type Designation	Equipment Terminal "A" (mm)	Conductor Diameter "B" (mm)	Angle of off-set (degrees)	Normal Rated Current @ 90°C [A rms]	Maximum Voltage [Um] (kV rms)	1s Short-Circuit Current Withstand Rating [kA rms]
EXC-A	26	26.5	0°	900	300	40.0
EXC-B	38	26.5	0°	900	300	40.0
EXC-C	38	38.3	0°	1350	420	40.0
EXC-D	38	38.3	45°	1350	420	40.0
EXC-E	38	38.3	90°	1350	420	40.0
EXC-F	38	26.5	45°	900	300	40.0
EXC-G	38	26.5	90°	900	300	40.0
EXC-H	38	18.1	0°	500	245	18.3
EXC-J	35	26.5	0°	900	300	40.0
EXC-K	35	38.3	0°	1200	420	40.0
EXC-L	26	26.5	45°	900	300	40.0
EXC-M	26	18.1	0°	500	245	18.3
EXC-N	40	26.5	0°	900	300	40.0
EXC-P	60	38.3	0°	1350	420	40.0
EXC-Q	60	38.3	45°	1350	420	40.0
EXC-R	60	38.3	90°	1350	420	40.0
EXC-S	60	26.5	0°	900	300	40.0
EXC-T	60	26.5	45°	900	300	40.0
EXC-U	60	26.5	90°	900	300	40.0

The following clamps shall be tested in accordance with section 3 of this standard:

**ESKOM COPYRIGHT PROTECTED**

- EXC-A or EXC-L, and
- EXC-B or EXC-F or EXC-G, and
- EXC-P or EXC-Q or EXC-R

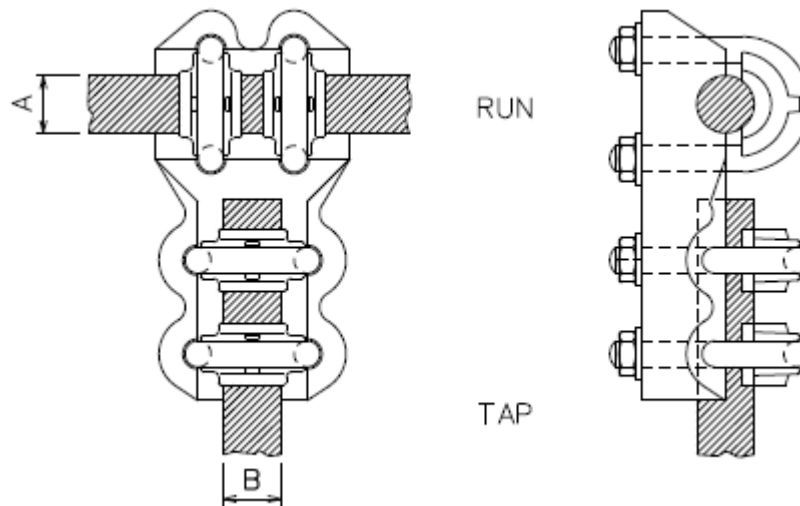

**Figure A.3: EUT Clamp**

**Table A.3: Type EUT Clamps**

Type Designation	Conductor Diameter Run "A" (mm)	Conductor Diameter Tap "B" (mm)	Normal Rated Current @ 90°C [A rms]	Maximum Voltage (Um) [kV rms]	1s Short-Circuit Current Withstand Rating [kA rms]
EUT-A	6 - 11	6 - 11	250	145	6.8
EUT-B	12 - 21	12 - 21	500	145	24.6
EUT-C	12 - 21	22 - 28	500	145	24.6
EUT-D	22 - 28	12 - 21	500	145	24.6
EUT-E	22 - 28	22 - 28	600	145	31.5
EUT-F	12 - 21	6 - 11	250	145	6.8
EUT-G	6 - 11	22 - 28	250	145	6.8

**Note:** EUT-G has previously been referred to as the EUT-C (MOD)

The following clamps shall be tested in accordance with section 3 of this standard:

- EUT-A
- EUT-B
- EUT-E

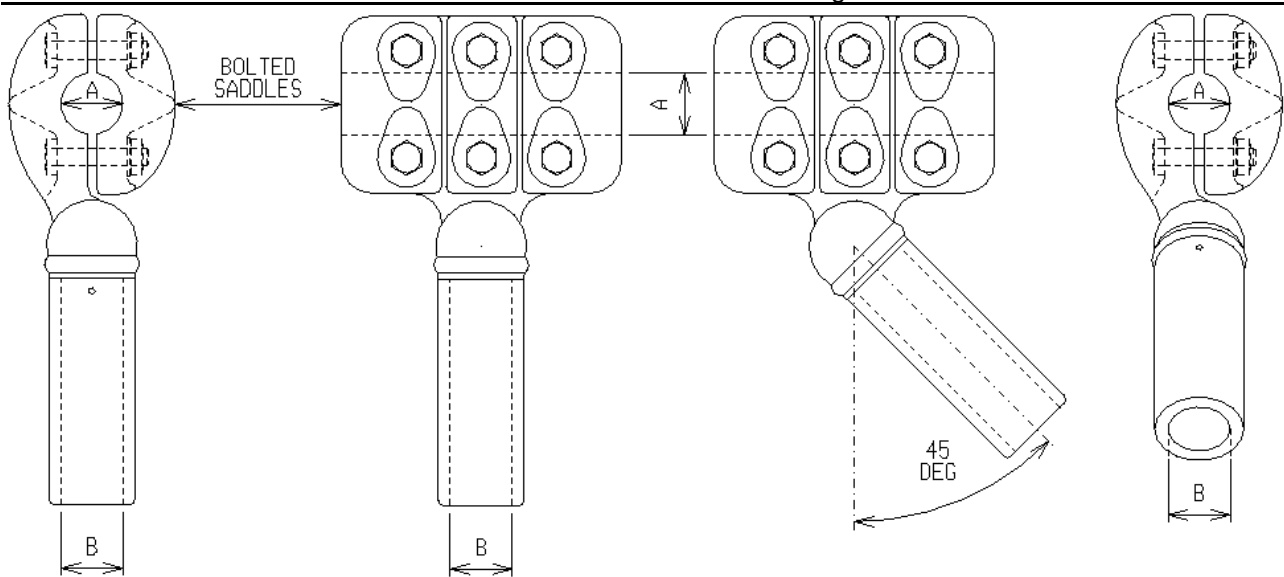

**Figure A.4: ETC Clamp**

**Table A.4: Type ETC Clamps**

Type Designation	Conductor Diameter Run "A" (mm)	Conductor Diameter Tap "B" (mm)	Angle of off-set (degrees)	Normal Rated Current @ 90°C [A rms]	Maximum Voltage [Um] (kV rms)	1s Short-Circuit Withstand Rating [kA rms]
ETC-A	23.5	26.5	0°	650	300	30.7
ETC-B	23.5	38.3	0°	650	300	30.7
ETC-C	26.5	26.5	0°	900	300	40.0
ETC-D	26.5	38.3	0°	900	300	40.0
ETC-E	28.6	26.5	0°	900	300	40.0
ETC-F	28.6	38.3	0°	900	300	40.0
ETC-G	35.6	26.5	0°	900	300	40.0
ETC-H	35.6	38.3	0°	1100	420	40.0
ETC-J	38.3	26.5	0°	900	300	40.0
ETC-K	38.3	38.3	0°	1350	420	40.0
ETC-L	18.1	26.5	0°	450	145	18.3
ETC-M	18.1	18.1	0°	450	145	18.3
ETC-N	26.5	18.1	0°	450	145	18.3
ETC-P	38.3	18.1	0°	450	145	18.3
ETC-Q	38.3	16	0°	450	145	15.7
ETC-R	26.5	16	0°	450	145	15.7
ETC-S	16	16	0°	450	145	15.7
ETC-T	26.5	26.5	45°	900	300	40.0
ETC-U	38.3	26.5	45°	900	300	40.0
ETC-V	38.3	38.3	45°	1350	420	40.0

**ESKOM COPYRIGHT PROTECTED**

Type Designation	Conductor Diameter Run "A" (mm)	Conductor Diameter Tap "B" (mm)	Angle of off-set (degrees)	Normal Rated Current @ 90°C [A rms]	Maximum Voltage [Um] (kV rms)	1s Short-Circuit Current Withstand Rating [kA rms]
ETC-W	18.1	16.25	0°	450	145	15.7
ETC-X	26.5	16.25	0°	450	145	15.7
ETC-Y	38.3	16.25	0°	450	145	15.7
ETC-Z	25.97	26.5	0°	800	300	37.7
ETC-AA	25.97	38.3	0°	800	300	37.7
ETC-AB	24.71	26.5	0°	750	145	34.3
ETC-AC	24.71	38.3	0°	750	145	34.3
ETC-AD	22.61	26.5	0°	650	145	28.7
ETC-AE	22.61	38.3	0°	650	145	28.7
ETC-AF	14.16	16.25	0°	450	145	11.7
ETC-AG	18.87	26.5	0°	900	300	20.8
ETC-AH	21.0	26.5	0°	900	300	24.6
ETC-AJ	23.9	38.3	0°	1350	300	33.5
ETC-AK	27.0	38.3	0°	1350	300	40.0

The following clamps shall be tested in accordance with section 3 of this standard:

- ETC-K
- ETC-L
- ETC-Q

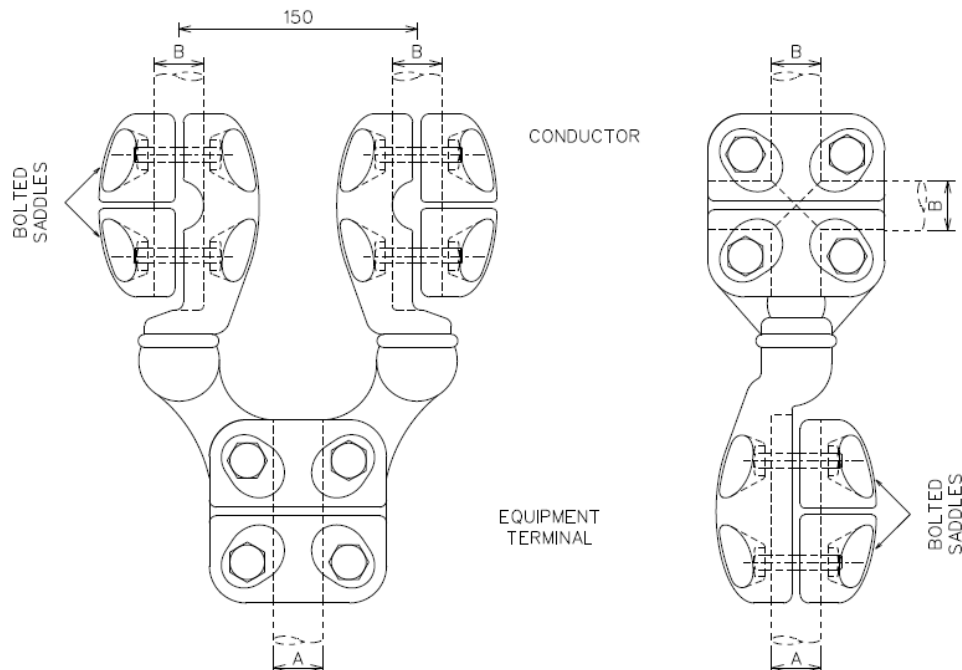

Figure A.5: EY Clamp

Table A.5: Type EY Clamps

Type Designation	Equipment Terminal "A" (mm)	Conductor Diameter "B" (mm)	Angle of off-set (degrees)	Normal Rated Current @ 90°C [A rms]	Maximum Voltage [Um] (kV rms)	1s Short-Circuit Current Withstand Rating with ES Spacer [kA rms]
EY-A	38	26.5	0°	1600	300	50
EY-B	38	38.3	0°	2500	420	63
EY-C	38	26.5	90°	1600	300	50
EY-D	38	38.3	90°	2500	420	63
EY-E	26	26.5	0°	1000	300	50
EY-F	26	26.5	90°	1000	300	50
EY-G	26	38.3	90°	1000	420	50
EY-H	26	38.3	0°	1000	420	50
EY-J	60	38.3	0°/ 90°	2500	420	63
EY-K	60	26.5	0°/ 90°	1600	300	50

**Notes:**

- All clamps shall be able to withstand 31.5kA (rms) for 1 second without the non-current carrying ES spacer butted up to the clamped saddles
- A single 'EY' clamp combined both 0° and 90° is acceptable (e.g. types "EY-A" and "EY-C").

The following clamps shall be tested in accordance with section 3 of this standard:

- EY-B or EY-D
- EY-E or EY-F

**ESKOM COPYRIGHT PROTECTED**

EY-J

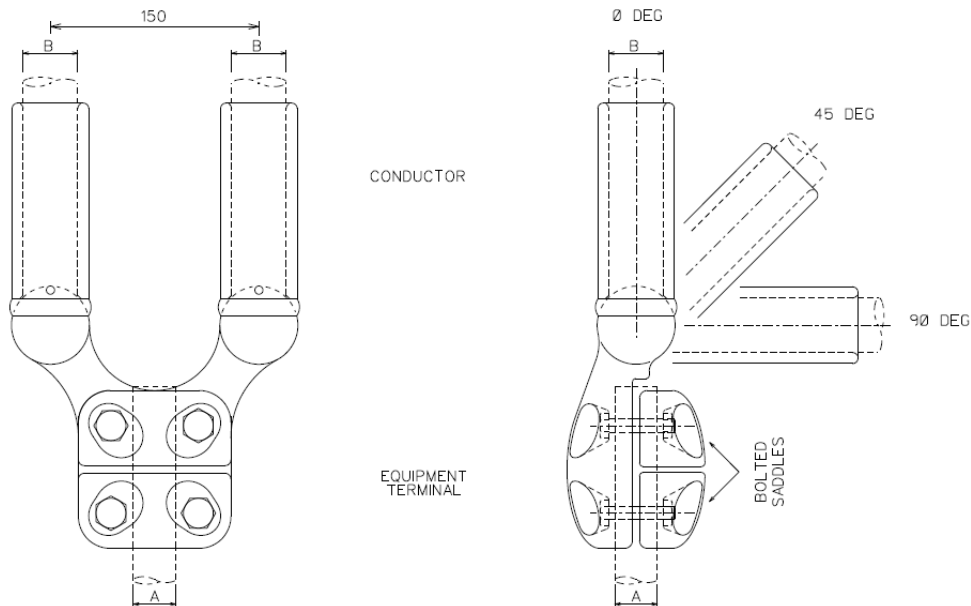

Figure A.6: EYC Clamp – Bolted Connection

Table A.6: Type EYC Clamps – Bolted

Type Designation	Equipment Terminal "A" (mm)	Conductor Diameter "B" (mm)	Angle of off-set (degrees)	Normal Rated Current @ 90°C [A rms]	Maximum Voltage [Um] (kV rms)	1s Short-Circuit Current Withstand Rating with ES Spacer [kA rms]
EYC-A	38	26.5	0°	1600	300	50
EYC-B	38	38.3	0°	2500	400	63
EYC-C	38	26.5	45°	1600	300	50
EYC-D	38	38.3	45°	2500	420	63
EYC-E	38	26.5	90°	1600	300	50
EYC-F	38	38.3	90°	2500	420	63
EYC-G	60	38.3	0°	2700	420	63
EYC-H	60	38.3	45°	2700	420	63
EYC-J	60	38.3	90°	2700	420	63
EYC-K	26	26.5	0°	1000	300	50
EYC-L	26	26.5	45°	1000	300	50
EYC-M	26	26.5	90°	1000	300	50
EYC-AA	60	26.5	0°	1700	300	50
EYC-AB	60	26.5	45°	1700	300	50
EYC-AC	60	26.5	90°	1700	300	50

**Note:** All clamps shall be able to withstand 31.5kA (rms) for 1 second without the non-current carrying ES spacer butted up to the crimped tube

The following clamps shall be tested in accordance with section 3 of this standard:

**ESKOM COPYRIGHT PROTECTED**

- EYC-D
- EYC-S

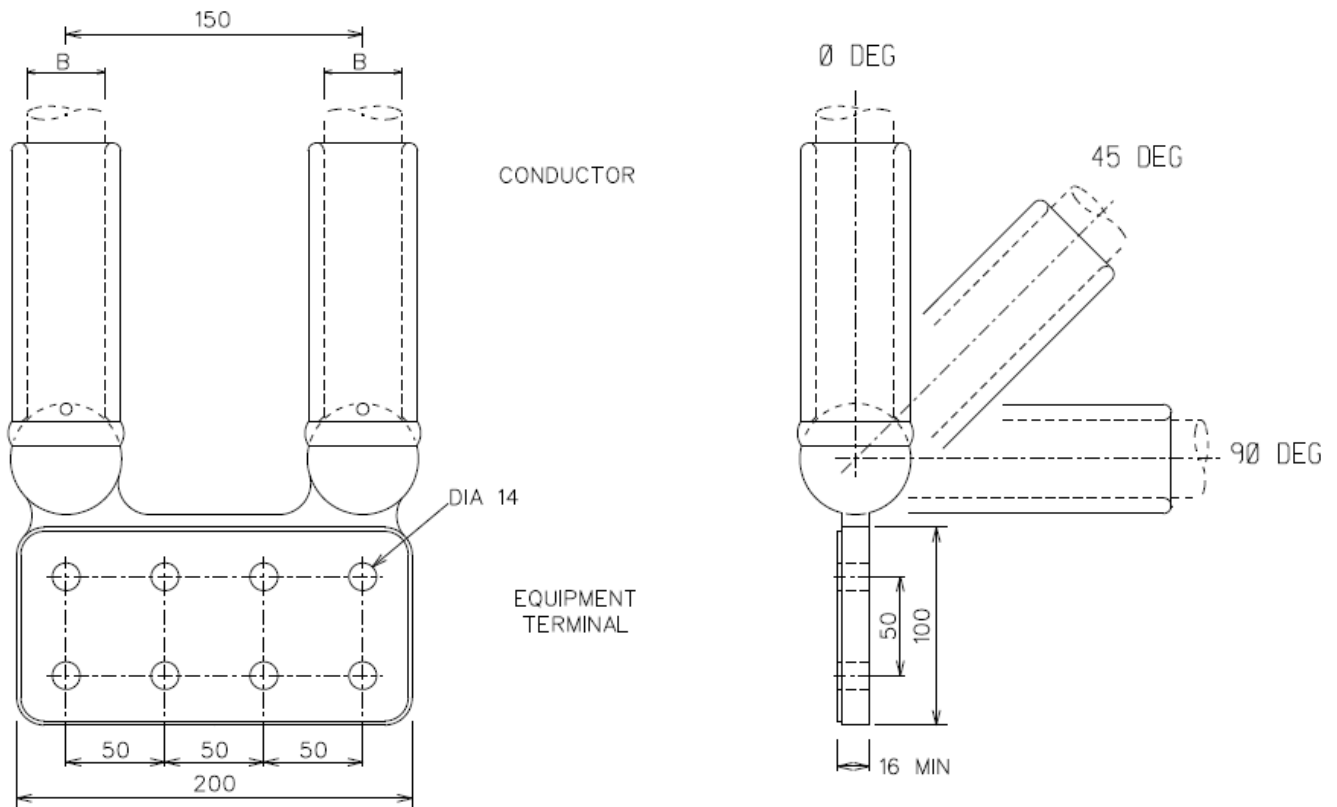

Figure A.7: EYC Clamp – 8-Hole Pad Connection

Table A.7: Type EYC Clamps – 8-Hole Pad

Type Designation	Equipment Terminal "A" (mm)	Conductor Diameter "B" (mm)	Angle of off-set (degrees)	Normal Rated Current @ 90°C [A rms]	Maximum Voltage [Um] (kV rms)	1s Short-Circuit Current Withstand Rating with ES Spacer [kA rms]
EYC-R	8 Bolt Pad to IEC 62271-301	38.3	0°	2700	420	63
EYC-S	8 Bolt Pad to IEC 62271-301	38.3	45°	2700	420	63
EYC-T	8 Bolt Pad to IEC 62271-301	38.3	90°	2700	420	63
EYC-X	8 Bolt Pad to IEC 62271-301	26.5	0°	1700	300	50
EYC-Y	8 Bolt Pad to IEC 62271-301	26.5	45°	1700	300	50
EYC-Z	8 Bolt Pad to IEC 62271-301	26.5	90°	1700	300	50

**Note:** All clamps shall be able to withstand 31.5kA (rms) for 1 second without the non-current carrying ES spacer butted up to the crimped tube

**ESKOM COPYRIGHT PROTECTED**

The following clamps shall be tested in accordance with section 3 of this standard:

- EYC-D
- EYC-S

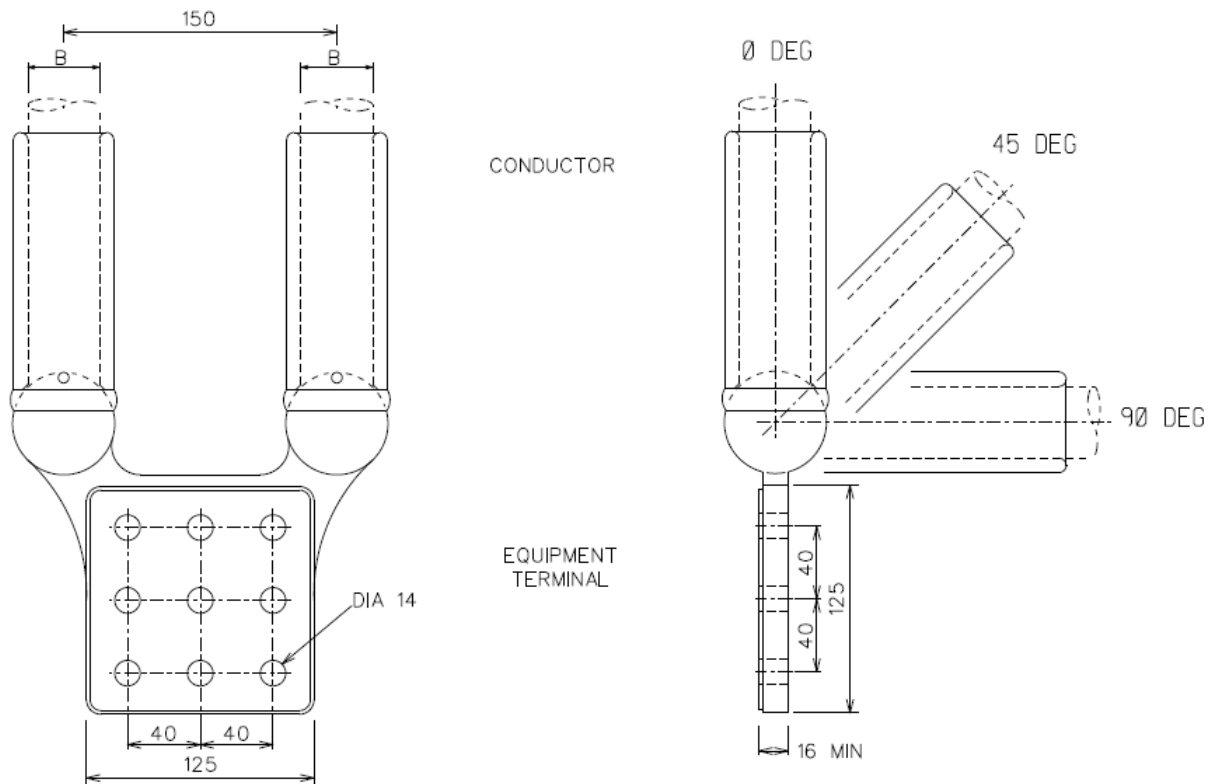

**Figure A.8: EYC Clamp – 9-Hole Pad Connection**

**Table A.8: Type EYC Clamps – 9-Hole Pad**

Type Designation	Equipment Terminal "A" (mm)	Conductor Diameter "B" (mm)	Angle of off-set (degrees)	Normal Rated Current @ 90°C [A rms]	Maximum Voltage [Um] (kV rms)	1s Short-Circuit Withstand Rating with ES Spacer [kA rms]
EYC-N	9 Bolt Pad to IEC 62271-301	38.3	0°	2700	420	63
EYC-P	9 Bolt Pad to IEC 62271-301	38.3	45°	2700	420	63
EYC-Q	9 Bolt Pad to IEC 62271-301	38.3	90°	2700	420	63
EYC-U	9 Bolt Pad to IEC 62271-301	26.5	0°	1700	300	50
EYC-V	9 Bolt Pad to IEC 62271-301	26.5	45°	1700	300	50
EYC-W	9 Bolt Pad to IEC 62271-301	26.5	90°	1700	300	50

**Note:** All clamps shall be able to withstand 31.5kA (rms) for 1 second without the non-current carrying ES spacer butted up to the crimped tube

**ESKOM COPYRIGHT PROTECTED**

The following clamps shall be tested in accordance with section 3 of this standard:

- EYC-D
- EYC-S

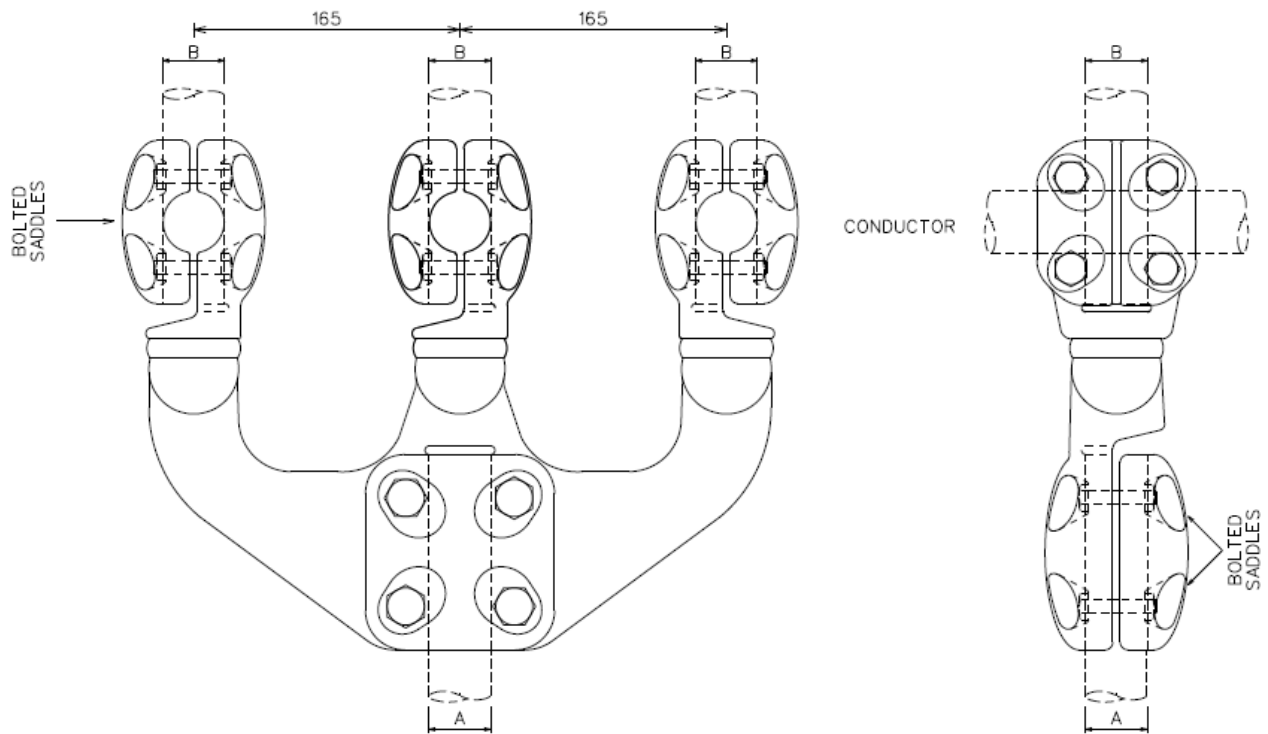

**Figure A.9: EY3 Type Bolted/Bolted Clamp for Stem Connection**

**Table A.9: Type EY3 Clamps**

Type Designation	Equipment Terminal "A" (mm)	Conductor Diameter "B" (mm)	Angle of off-set (degrees)	Normal Rated Current @ 90°C [A rms]	Maximum Voltage [Um] (kV rms)	1s Short-Circuit Current Withstand Rating with ES Spacer [kA rms]
EY3-A	38	38.3	90°	2500	420	63
EY3-B	60	38.3	90°	3150	420	63

**Note:** All clamps shall be able to withstand 31.5kA (rms) for 1 second without the non-current carrying ES spacer butted up to the clamp body

The following clamps shall be tested in accordance with section 3 of this standard:

- EY3-B

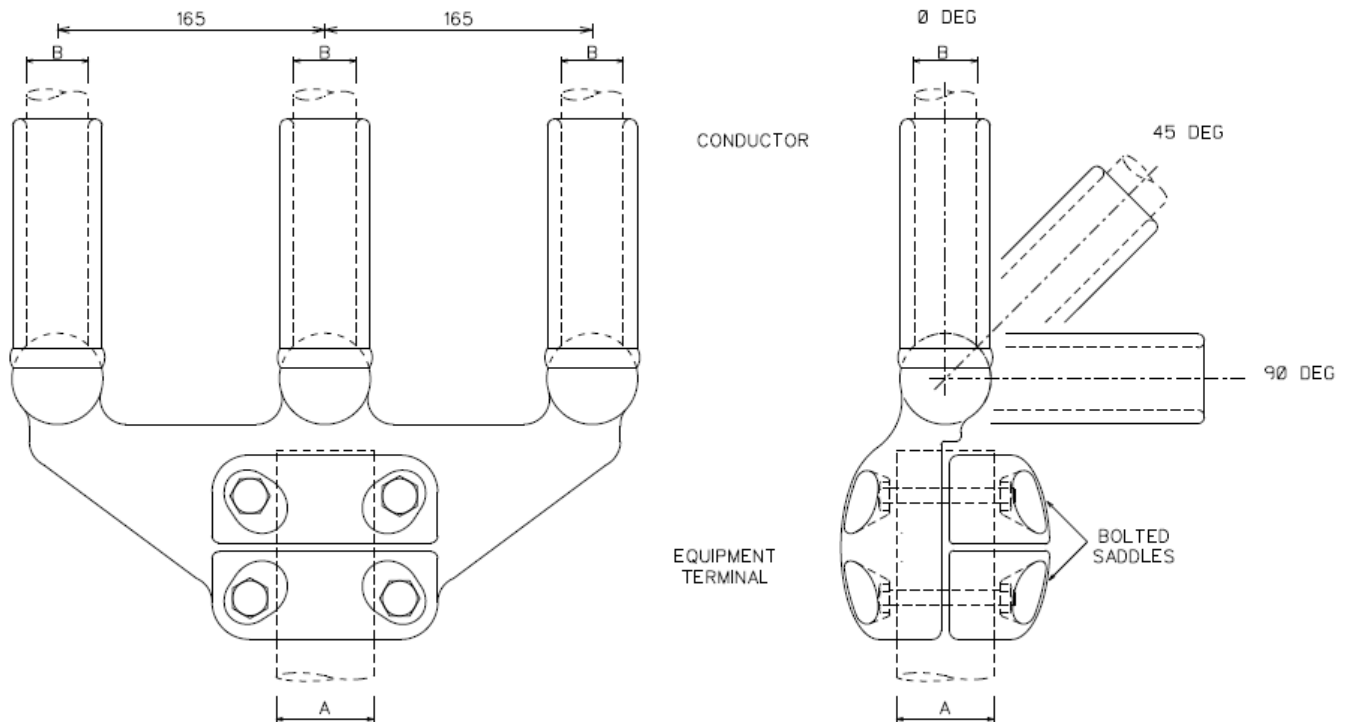

Figure A.10: EYC3 Bolted/Compression Clamp for Stem Connection

Table A.10: Type EYC3 Clamps – Bolted

Type Designation	Equipment Terminal "A" (mm)	Conductor Diameter "B" (mm)	Angle of off-set (degrees)	Normal Rated Current @ 90°C [A rms]	Maximum Voltage [Um] (kV rms)	1s Short-Circuit Current Withstand Rating with ES Spacer [kA rms]
EYC3-A	60	38.3	0°	4000	420	63
EYC3-C	60	38.3	45°	4000	420	63
EYC3-E	60	38.3	90°	4000	420	63

**Note:** All clamps shall be able to withstand 31.5kA (rms) for 1 second without the non-current carrying ES spacer butted up to the crimped tube

The following clamps shall be tested in accordance with section 3 of this standard:

- EYC3-A
- EYC3-D

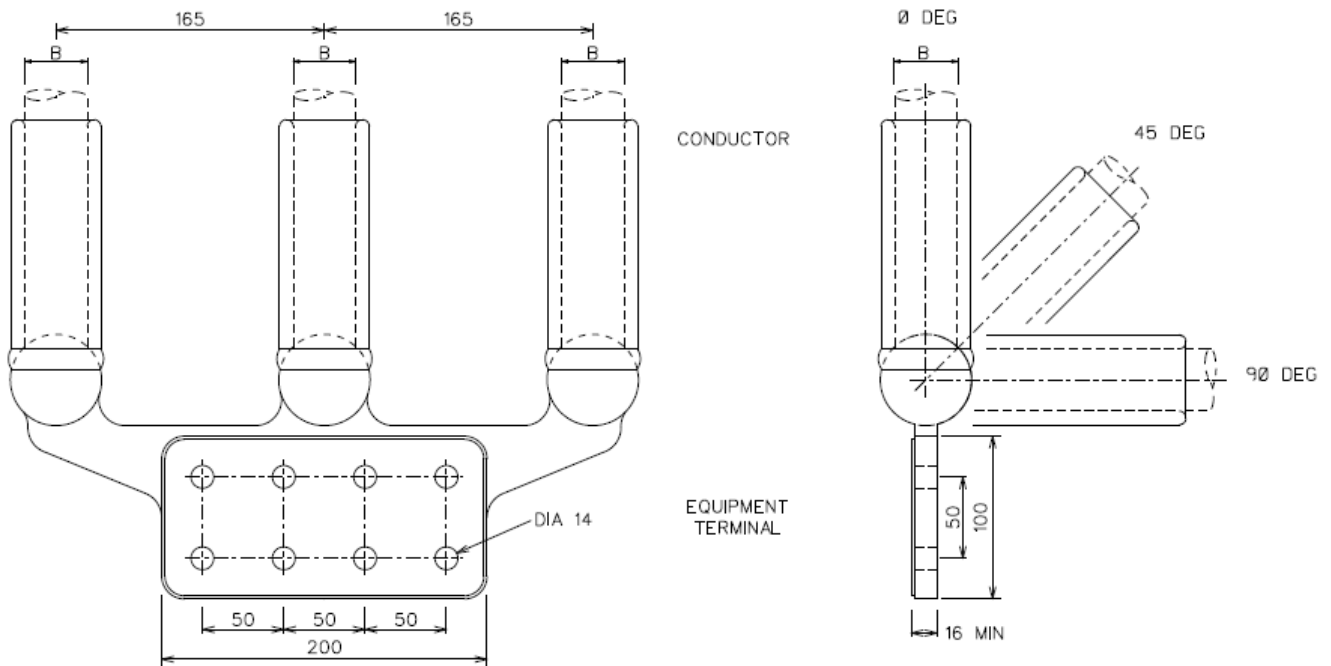

Figure A.11: EYC3 Bolted/Compression Clamp for 8-Hole Pad Connection

Table A.11: Type EYC3 Clamps – 8-Hole Pad

Type Designation	Equipment Terminal "A" (mm)	Conductor Diameter "B" (mm)	Angle of off-set (degrees)	Normal Rated Current @ 90°C [A rms]	Maximum Voltage [Um] (kV rms)	1s Short-Circuit Current Withstand Rating with ES Spacer [kA rms]
EYC3-G	8 Bolt Pad to IEC 62271-301	38.3	0°	4000	420	63
EYC3-H	8 Bolt Pad to IEC 62271-301	38.3	45°	4000	420	63
EYC3-J	8 Bolt Pad to IEC 62271-301	38.3	90°	4000	420	63

**Note:** All clamps shall be able to withstand 31.5kA (rms) for 1 second without the non-current carrying ES spacer butted up to the crimped tube

The following clamps shall be tested in accordance with section 3 of this standard:

- EYC3-A
- EYC3-D

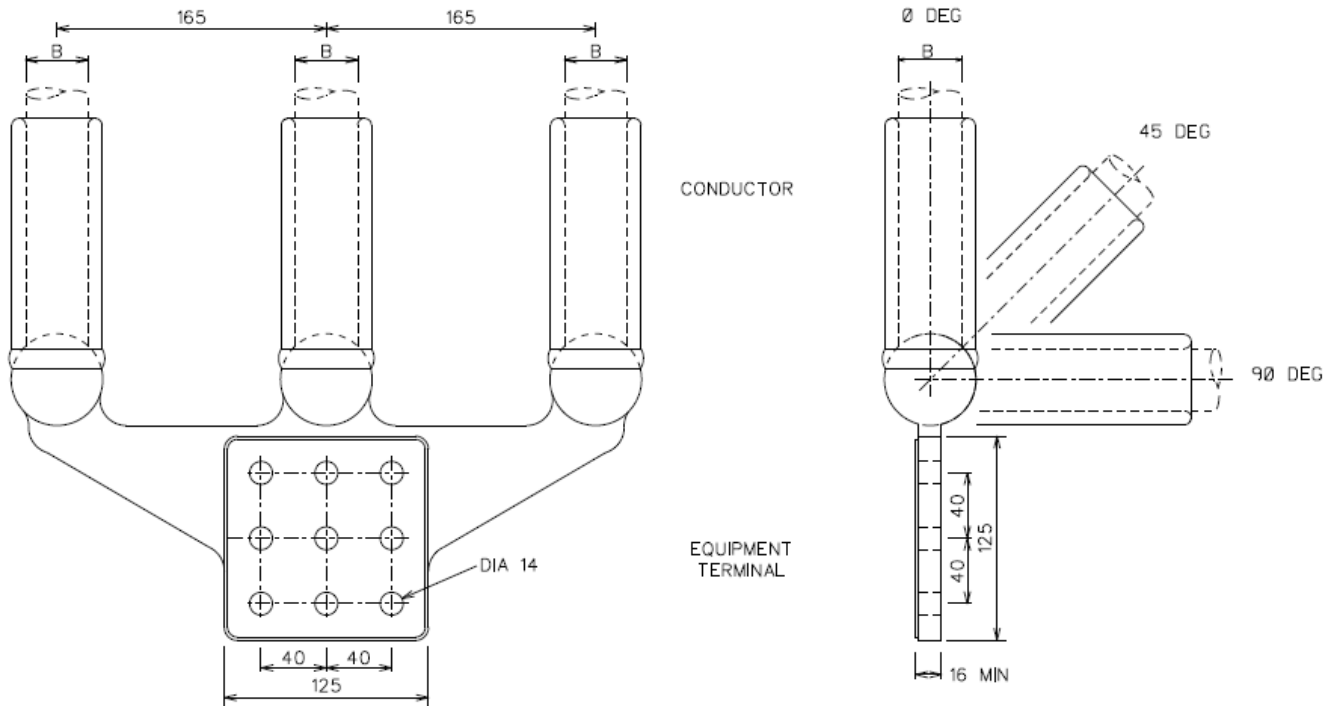

Figure A.12: EYC3 Bolted/Compression Clamp for 9-Hole Pad Connection

Table A.12: Type EYC3 Clamps – 9-Hole Pad

Type Designation	Equipment Terminal "A" (mm)	Conductor Diameter "B" (mm)	Angle of off-set (degrees)	Normal Rated Current @ 90°C [A rms]	Maximum Voltage [Um] (kV rms)	1s Short-Circuit Current Withstand Rating with ES Spacer [kA rms]
EYC3-B	9 Bolt Pad to IEC 62271-301	38.3	0°	4000	420	63
EYC3-D	9 Bolt Pad to IEC 62271-301	38.3	45°	4000	420	63
EYC3-F	9 Bolt Pad to IEC 62271-301	38.3	90°	4000	420	63

**Note:** All clamps shall be able to withstand 31.5kA (rms) for 1 second without the non-current carrying ES spacer butted up to the crimped tube

The following clamps shall be tested in accordance with section 3 of this standard:

- EYC3-A
- EYC3-D

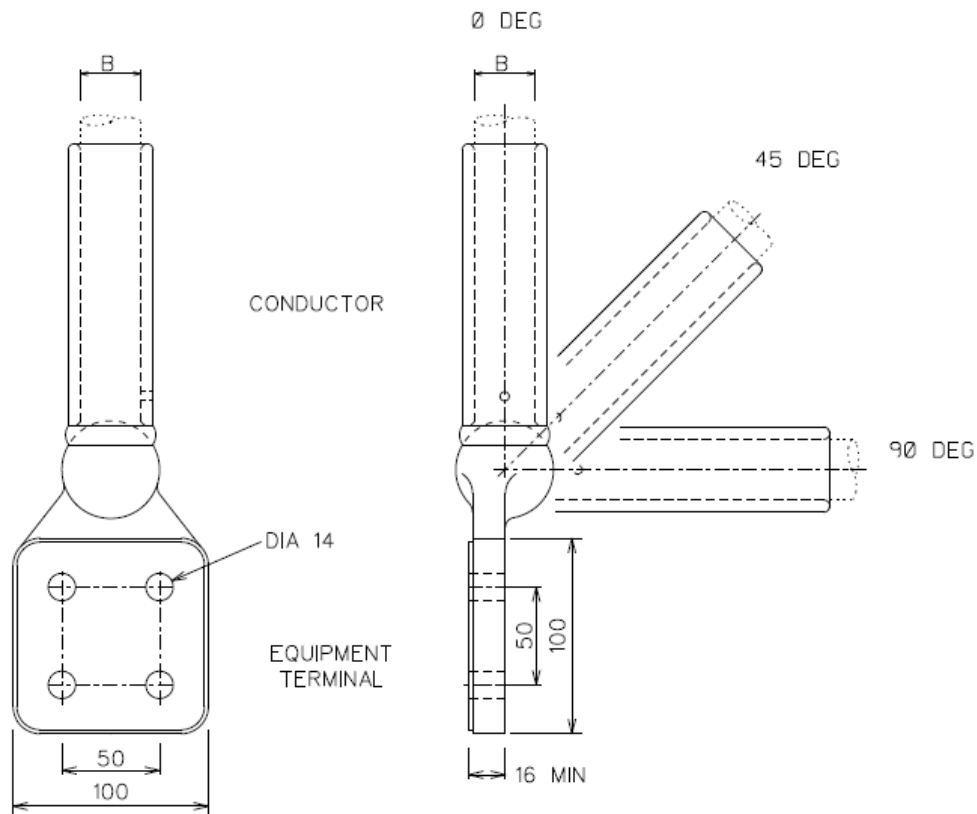

Figure A.13: EPC Clamp 100x100mm Pad

Table A.13: Type EPC Clamps – 100x100mm Pad

Type Designation	Equipment Terminal "A" (mm)	Conductor Diameter "B" (mm)	Angle of off-set (degrees)	Normal Rated Current @ 90°C [A rms]	Maximum Voltage [Um] (kV rms)	1s Short-Circuit Current Withstand Rating [kA rms]
EPC-A	100 x 100 Pad	26.5	0°	900	245	40.0
EPC-B	4 x 14 Dia holes	26.5	45°	900	245	40.0
EPC-C	50 x 50 Centres	26.5	90°	900	245	40.0
EPC-D	100 x 100 Pad	38.3	0°	1350	300	40.0
EPC-E	4 x 14 Dia holes	38.3	45°	1350	300	40.0
EPC-F	50 x 50 Centres	38.3	90°	1350	300	40.0
EPC-Q	100 x 100 Pad	16.3	0	500	145	15.7
EPC-R	4 x 14 Dia holes	16.3	45	500	145	15.7
EPC-S	50 x 50 Centres	16.3	90	500	145	15.7

The following clamps shall be tested in accordance with section 3 of this standard:

- EPC-A
- EPC-E

**ESKOM COPYRIGHT PROTECTED**

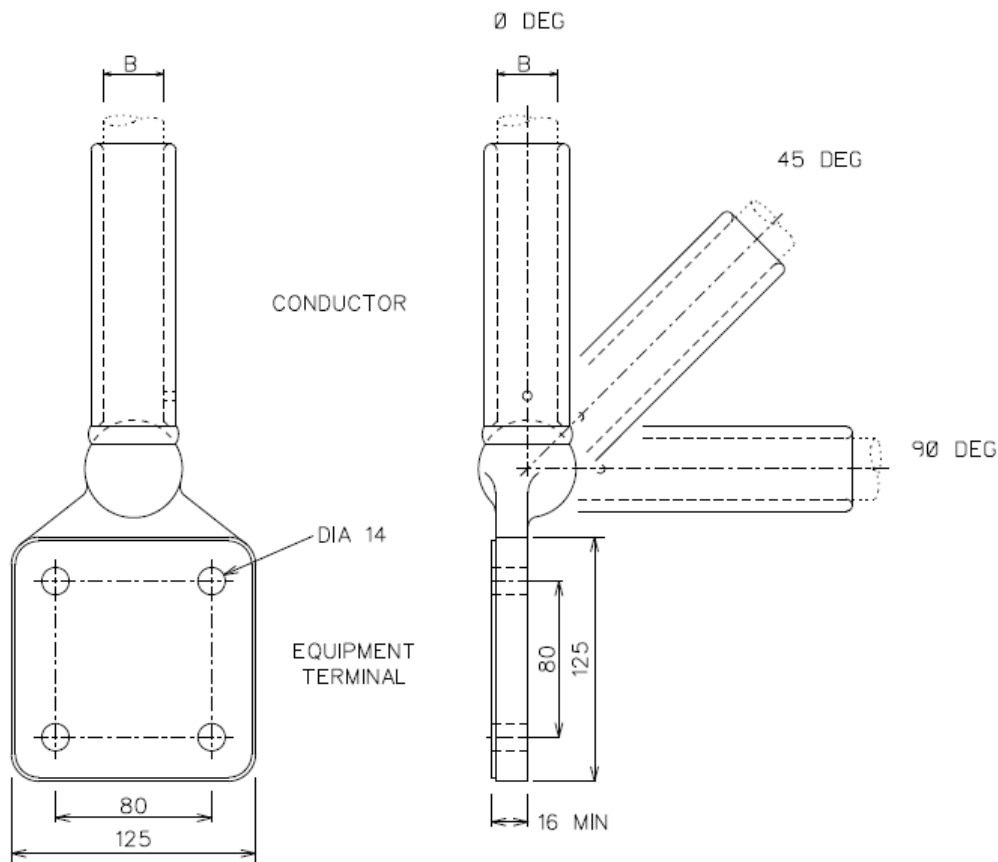

Figure A.14: EPC Clamp 125x125mm Pad

Table A.14: Type EPC Clamps – 125x125mm Pad

Type Designation	Equipment Terminal "A" (mm)	Conductor Diameter "B" (mm)	Angle of off-set (degrees)	Normal Rated Current @ 90°C [A rms]	Maximum Voltage [Um] (kV rms)	1s Short-Circuit Current Withstand Rating [kA rms]
EPC-G	125 x 125 Pad	26.5	0°	900	245	40
EPC-H	4 x 14 Dia holes	26.5	45°	900	245	40
EPC-J	80 x 80 Centres	26.5	90°	900	245	40
EPC-K	125 x 125 Pad	38.3	0°	1350	300	40
EPC-L	4 x 14 Dia holes	38.3	45°	1350	300	40
EPC-M	80 x 80 Centres	38.3	90°	1350	300	40

The following clamps shall be tested in accordance with section 3 of this standard:

- EPC-A
- EPC-E

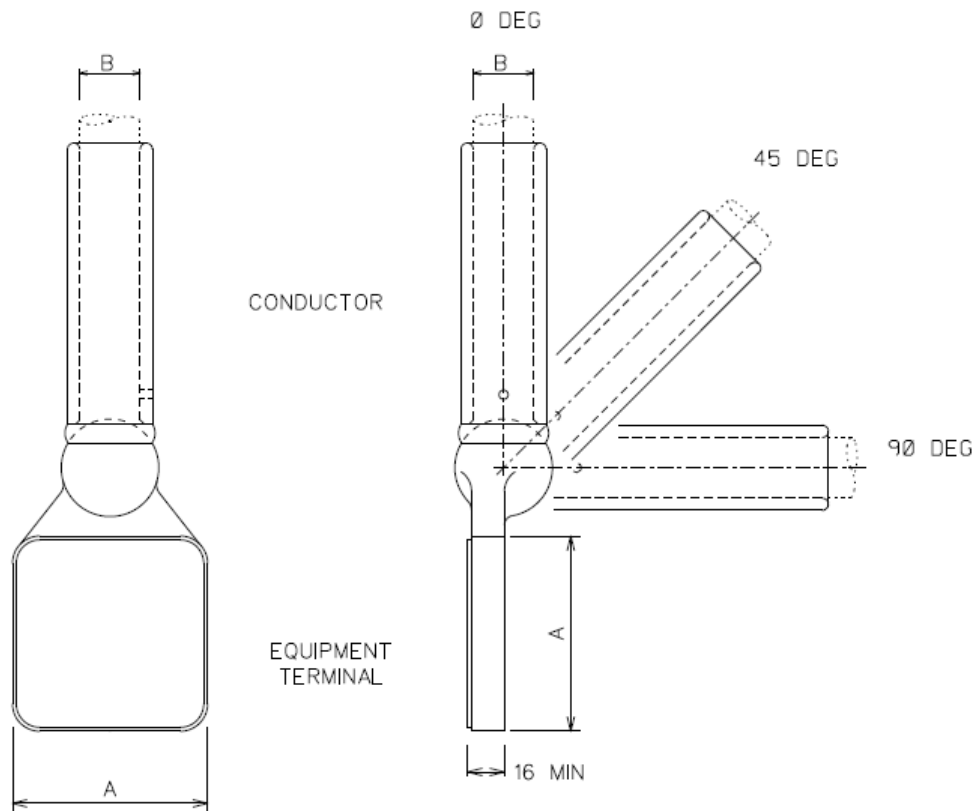

Figure A.15: EPC Clamp Undrilled Pad

Table A.15: Type EPC Clamps – Undrilled Pad

Type Designation	Equipment Terminal "A" (mm)	Conductor Diameter "B" (mm)	Angle of off-set (degrees)	Normal Rated Current @ 90°C [A rms]	Maximum Voltage [Um] (kV rms)	1s Short-Circuit Current Withstand Rating [kA rms]
EPC-N	Undrilled Pad 100 x 100	26.5	0°	900	245	40
EPC-P	Undrilled Pad 125 x 125	38.3	0°	1350	300	40

The following clamps shall be tested in accordance with section 3 of this standard:

- EPC-A
- EPC-E

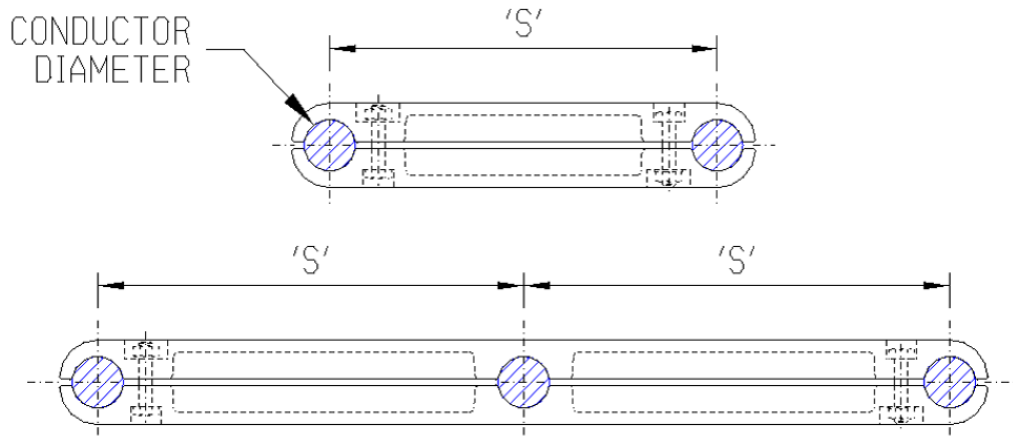

Figure A.16: ES Spacers

Table A.16: Type ES Spacers

Type Designation	Conductor Diameter "A" (mm)	Spacing "S" (mm)	Number of Conductors	Minimum Compression Forces (kN)	Maximum Voltage [Um] (kV rms)
ES-A	26.5	150	2	7	300
ES-B	38.3	150	2	8.5	420
ES-C	26.5	330	2	8	300
ES-D	38.3	330	2	13	420
ES-E	38.3	165	3	13	420

**ESKOM COPYRIGHT PROTECTED**

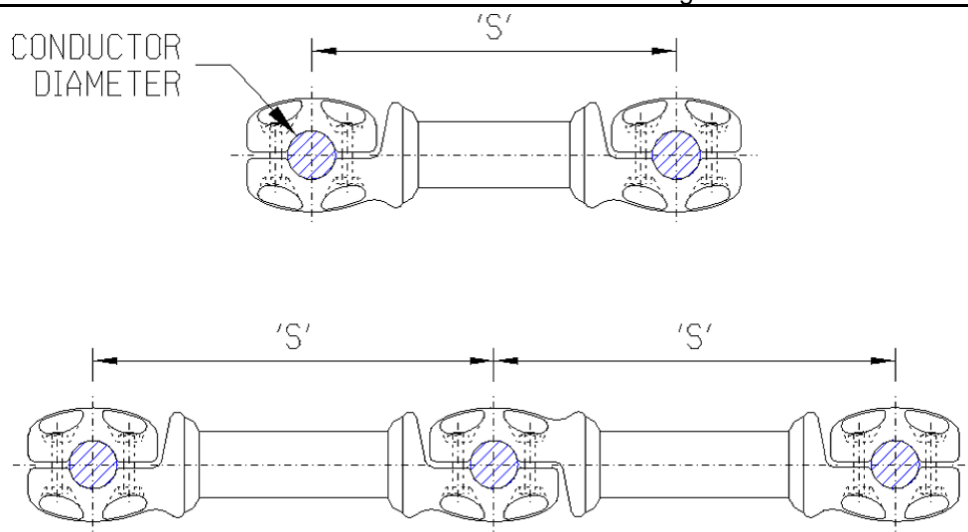

Figure A.17: ESC Spacer

Table A.17: Type ESC Spacers

Type Designation	Conductor Diameter "A" (mm)	Spacing "S" (mm)	Number of Conductors	Minimum Compression Forces (kN)	Normal Rated Current @ 90°C [A rms]	Maximum Voltage [Um] (kV rms)	1s Short-Circuit Current Withstand Rating [kA rms]
ESC-A	26.5	150	2	7	900	300	50
ESC-B	38.3	150	2	8.5	1350	420	63
ESC-C	26.5	330	2	8	900	300	50
ESC-D	38.3	330	2	13	1350	420	63
ESC-E	38.3	165	3	13	1350	420	63

The following clamps shall be tested in accordance with section 3 of this standard:

- ESC-A
- ESC-B
- ESC-D

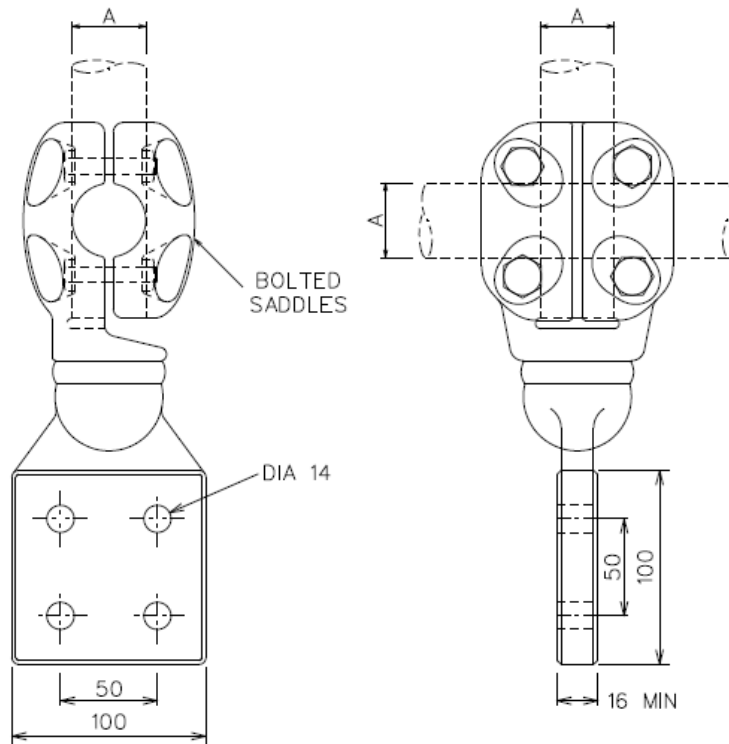

**Figure A.18: EXP Clamp**

**Table A.18: Type EXP Clamps**

Type Designation	Stem Diameter A (mm)	Palm Size (mm)	Normal Rated Current @ 90°C (A rms)	Maximum Voltage [Um] (kV rms)	1s Short-Circuit Current Withstand Rating [kA rms]
EXP-A	26	100x100	900	245	40
EXP-B	38	100x100	1350	300	40

The following clamps shall be tested in accordance with section 3 of this standard:

- EXP-B

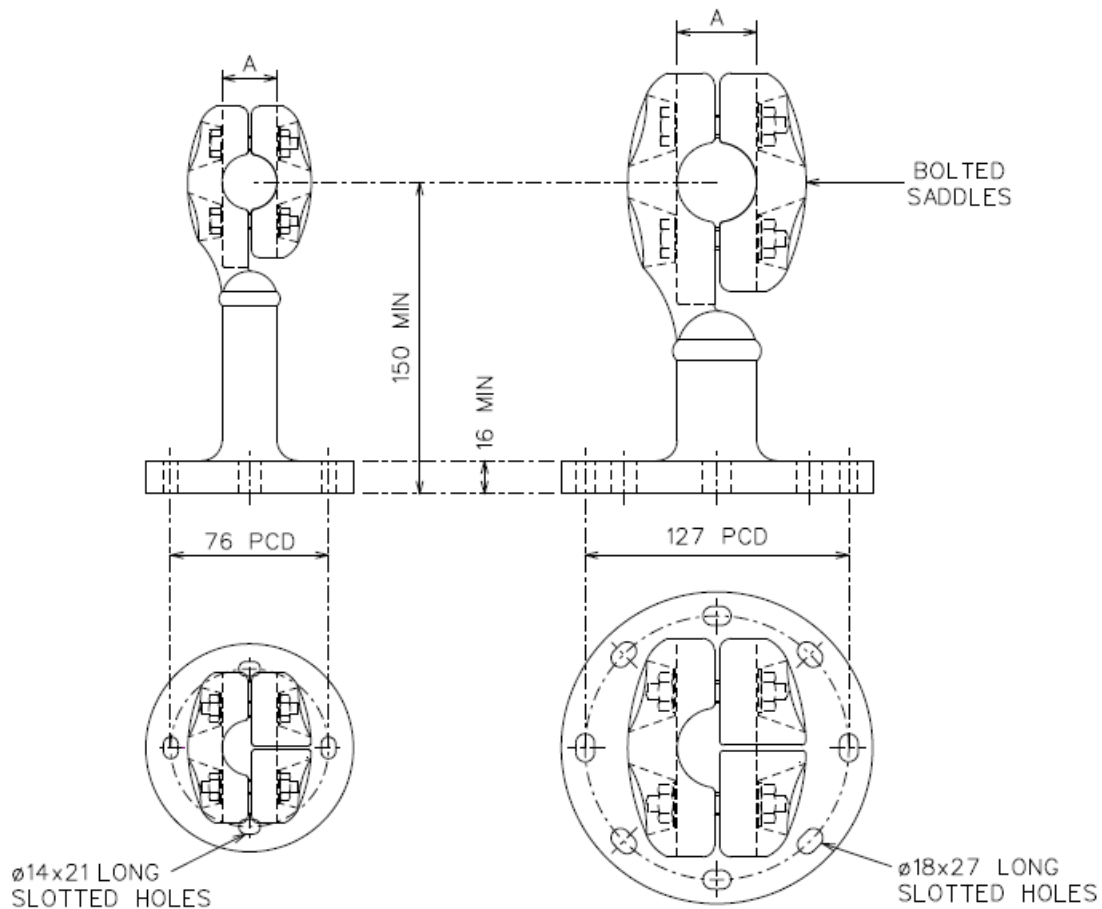

Figure A.19: EXCP Clamp

Table A.19: Type EXCP Clamps

Type Designation	Equipment Terminal PCD [mm]	Conductor Diameter "A" (mm)	Maximum Voltage [Um] (kV rms)
EXCP-A	76	26.5	145
EXCP-B	127	26.5	145
EXCP-C	76	38.3	145
EXCP-D	127	38.3	145

The following clamps shall be tested in accordance with section 3 of this standard:

- EXCP-D



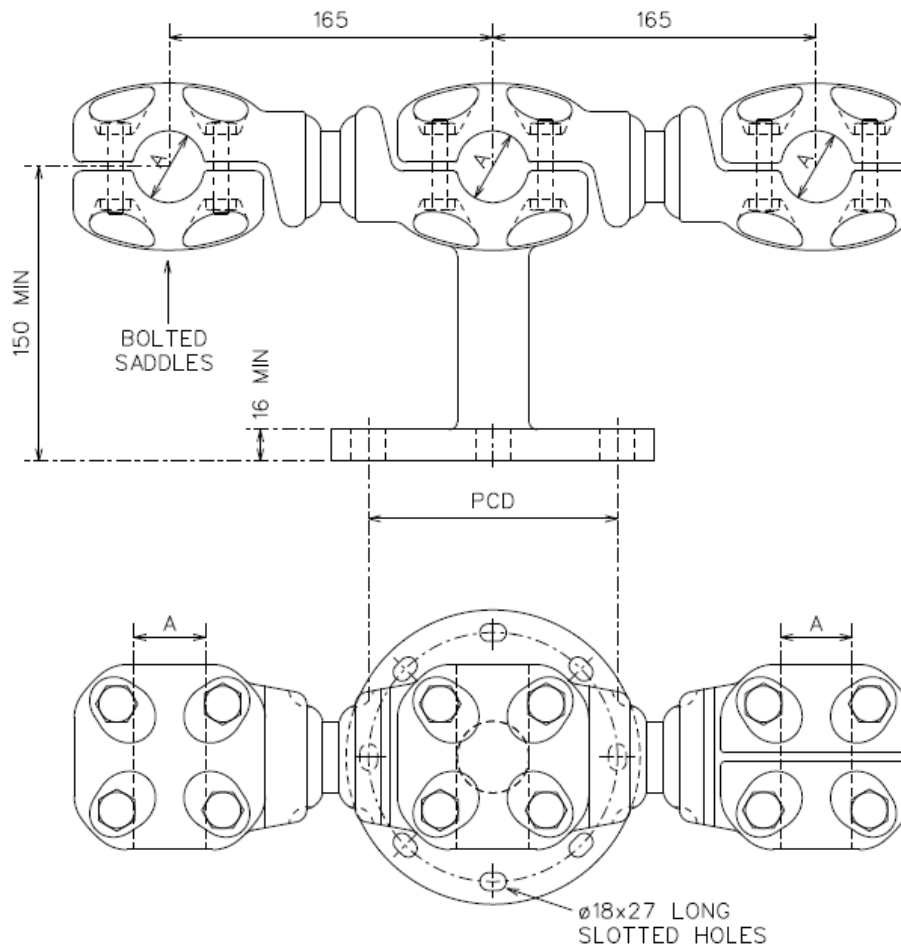

**Figure A.21: EXCP3 Post Insulator mounted triple conductor clamp**

**Table A.21: Type EXCP3 Clamps**

Type Designation	Equipment Terminal PCD (mm)	Conductor Diameter "A" (mm)	Conductor Centre Spacing (mm)	Maximum Voltage [Um] (kV rms)
EXCP3-A	127	3 x 26.5	165	300
EXCP3-B	127	3 x 38.3	165	420
EXCP3-C	225	3 x 38.3	165	420

The following clamps shall be tested in accordance with section 3 of this standard:

- EXCP3-B

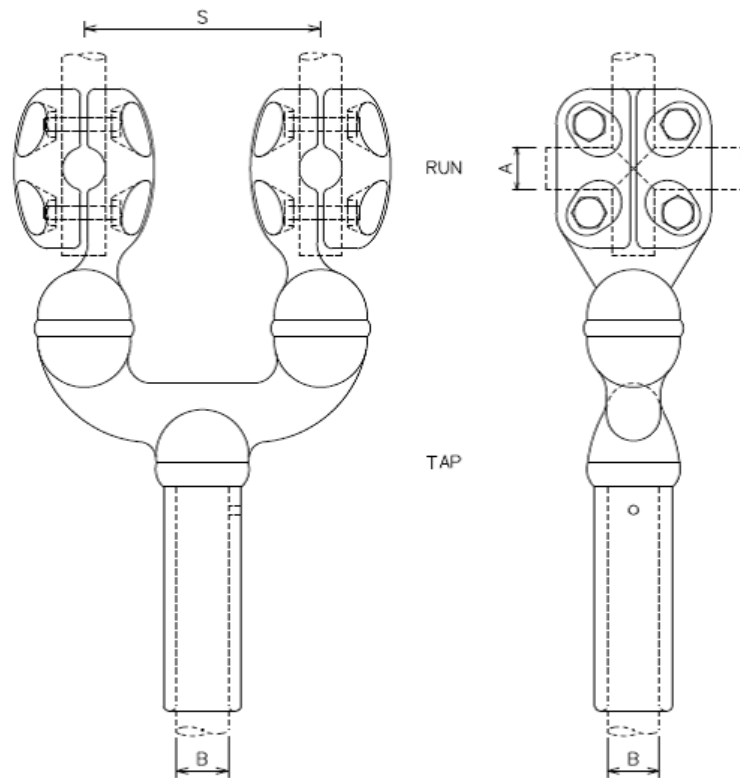

Figure A.22: EYBC Clamp

Table A.22: Type EYBC Clamps

Type Designation	Conductor Diameter "A" (mm)	Conductor Diameter "B" (mm)	Centre Spacing "S" (mm)	Normal Rated Current @ 90°C (A rms)	Maximum Voltage [Um] (kV rms)	1s Short-Circuit Current Withstand Rating with ES Spacer [kA rms]
EYBC-A	2x26.5	26.5	150	900	300	40
EYBC-B	2x26.5	38.3	330	1350	420	40
EYBC-C	2x38.3	26.5	150	900	300	40
EYBC-D	2x38.3	38.3	150	1350	420	40
EYBC-E	2x38.3	38.3	330	1350	420	40

**Note:** All clamps shall be able to withstand 31.5kA rms for 1 second without the non-current carrying ES spacer butted up to the clamp body.

The following clamps shall be tested in accordance with section 3 of this standard:

- EYBC-E

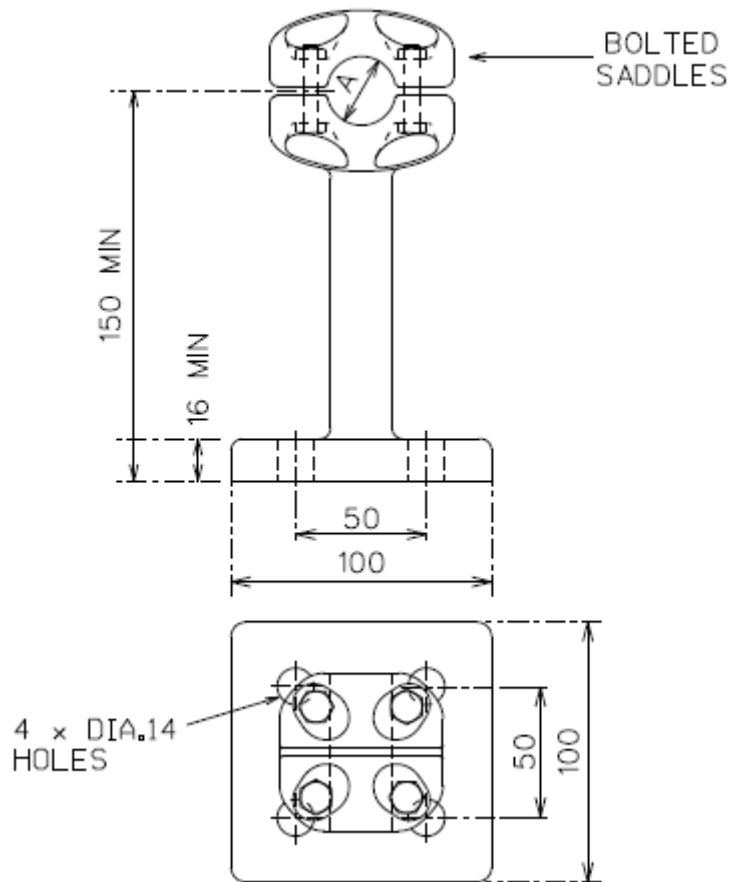

Figure A.23: EPT Clamp

Table A.23: Type EPT Clamps

Type Designation	Equipment Terminal	Conductor Diameter "A" (mm)	Normal Rated Current @ 90°C (A rms)	Maximum Voltage [Um] (kV rms)	1s Short-Circuit Current Withstand Rating [kA rms]
EPT-A	4 Bolt Pad to IEC 62271-301	26.5	900	145	40
EPT-B	4 Bolt Pad to IEC 62271-301	38.3	1350	145	40

The following clamps shall be tested in accordance with section 3 of this standard:

- EPT-B

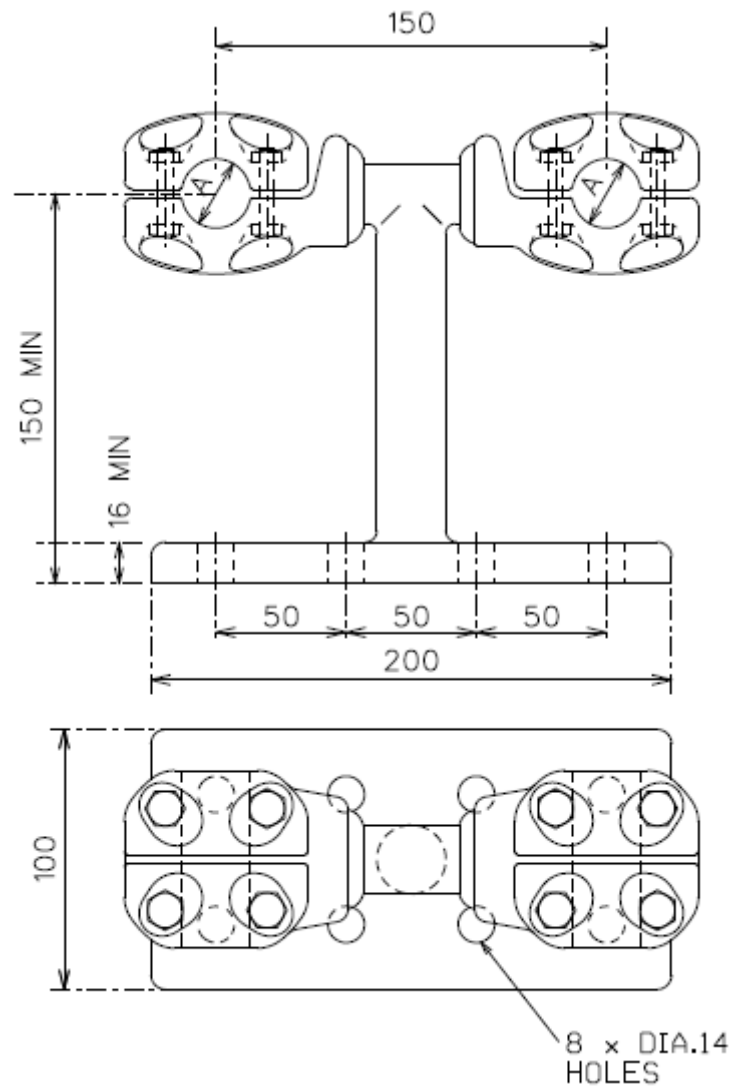

Figure A.24: EPT2 Clamp

Table A.24: Type EPT2 Clamps

Type Designation	Equipment Terminal	Conductor Diameter "A" (mm)	Centre Spacing (mm)	Normal Rated Current @ 90°C (A rms)	Maximum Voltage [Um] (kV rms)	1s Short-Circuit Current Withstand Rating with ES Spacer [kA rms]
EPT2-A	8 Bolt Pad to IEC 62271-301	2x26.5	150	1700	300	50
EPT2-B	8 Bolt Pad to IEC 62271-301	2x38.3	150	2700	420	63

**Note:** All clamps shall be able to withstand 31.5kA rms for 1 second without the non-current carrying ES spacer butted up to the clamp body.

The following clamps shall be tested in accordance with section 3 of this standard:

- EPT2-B

**ESKOM COPYRIGHT PROTECTED**

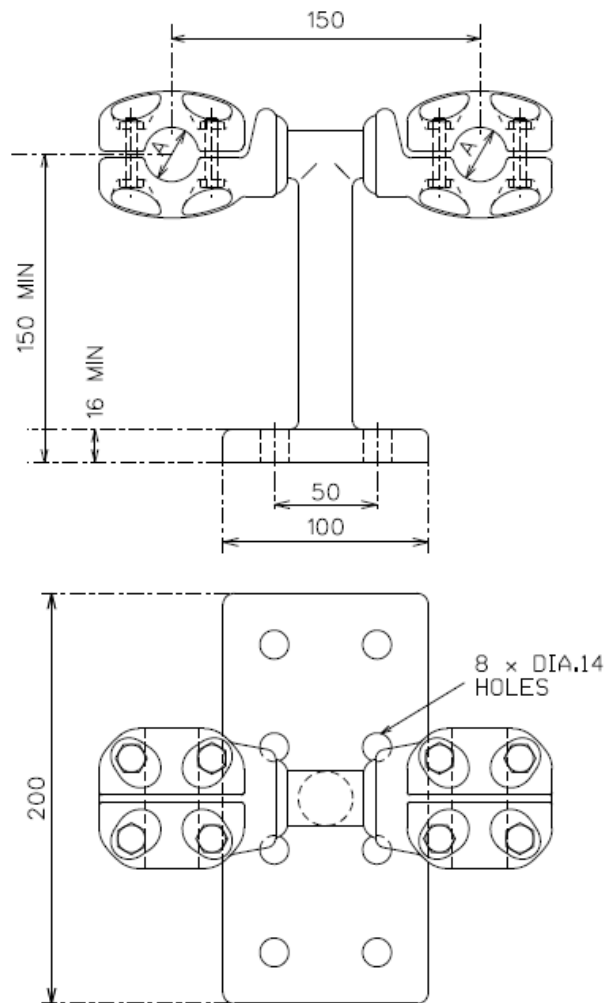

Figure A.25: EPTT2 Twin conductor bolted support clamp on 8-hole pad to fit 8-hole terminal

Table A.25: Type EPTT2 Clamps

Type Designation	Equipment Terminal	Conductor Diameter "A" (mm)	Centre Spacing (mm)	Normal Rated Current @ 90°C (A rms)	Maximum Voltage [Um] (kV rms)	1s Short-Circuit Current Withstand Rating with ES Spacer [kA rms]
EPTT2-A	8 Bolt Pad to SANS 62271-301	2 x 26.5	150	1,700	300	50
EPTT2-B	8 Bolt Pad to SANS 62271-301	2 x 38.3	150	2,700	420	63

**Note:** All clamps shall be able to withstand 31.5kA rms for 1 second without the non-current carrying ES spacer butted up to the clamp body.

The following clamps shall be tested in accordance with section 3 of this standard:

- EPTT2-B

**ESKOM COPYRIGHT PROTECTED**

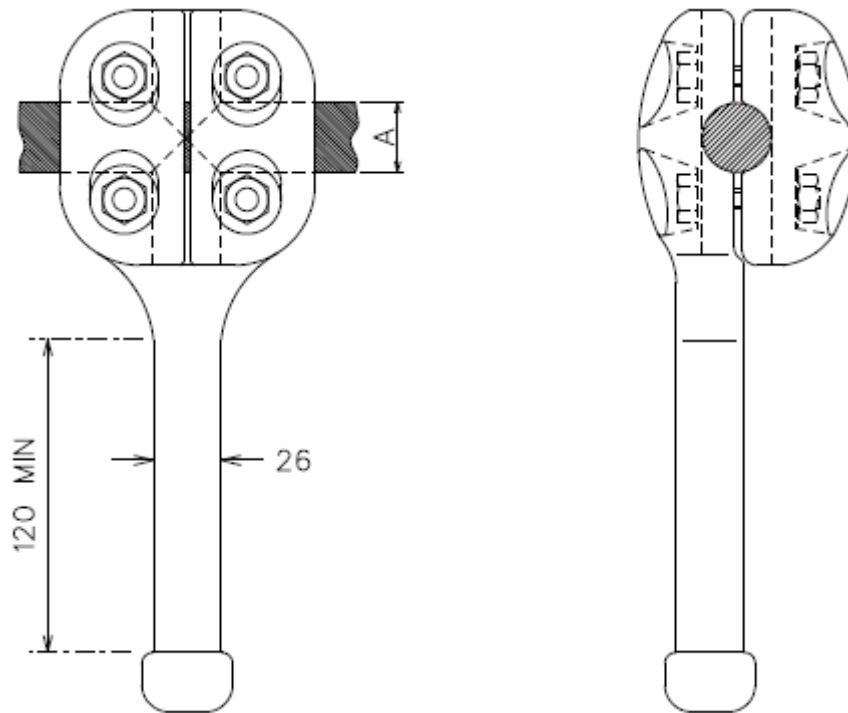

**Figure A.26: EEPC Clamp**

**Table A.26: Type EEPC Clamps**

Type Designation	Conductor Diameter "A" / "B" (mm)	Stem Diameter (mm)	Maximum Voltage [Um] (kV rms)	1s Short-Circuit Current Withstand Rating [kA rms]
EEPC-A	26.5	26	300	20
EEPC-B	38.3	26	420	20
EEPC-C	16.3	26	145	20

The following clamps shall be tested in accordance with section 3 of this standard:

- EEPC-A

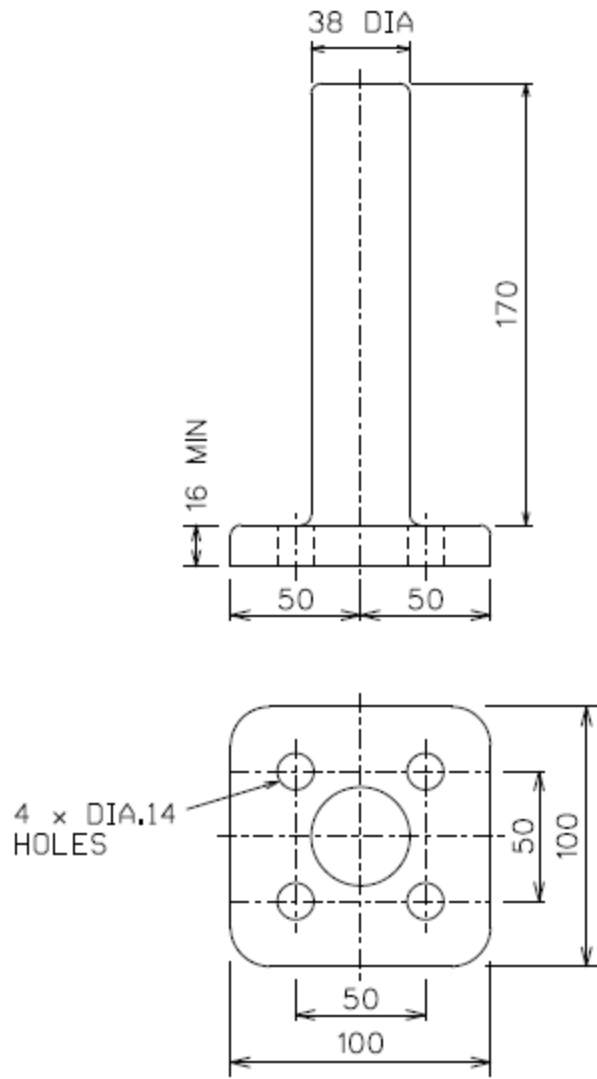

Figure 27: EESP Clamp

Table A.27: Type EESP Clamps

Type Designation	Equipment Terminal (mm)	Stem Diameter (mm)	Normal Rated Current @ 90°C (A rms)	Maximum Voltage [Um] (kV rms)	1s Short-Circuit Current Withstand Rating [kA rms]
EESP-A	4 Bolt Pad to IEC 62271-301	38	1350	420	40

The following clamps shall be tested in accordance with section 3 of this standard:

- EESP-A

**ESKOM COPYRIGHT PROTECTED**

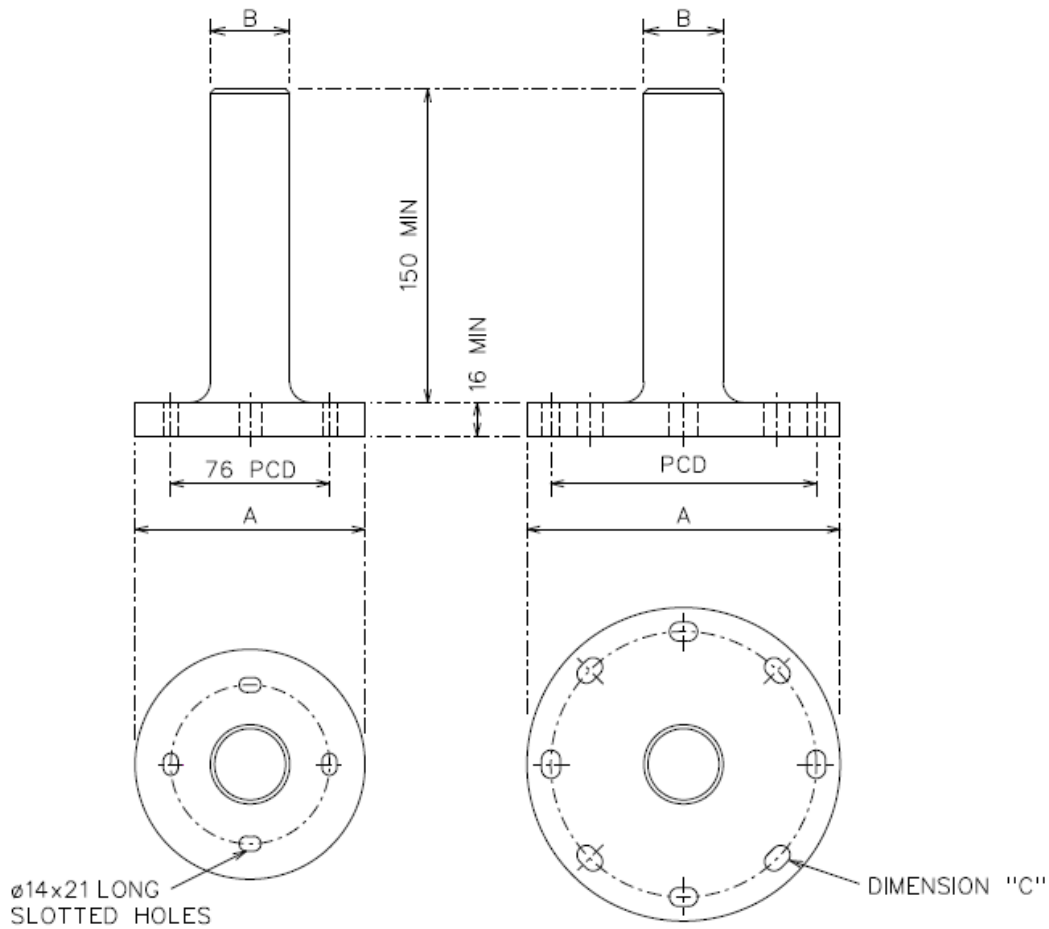

Figure A.28: EPISF Post Insulator Stem fitting

Table A.28: Type EPISF Clamps

Type Designation	Equipment Terminal PCD (mm)	Overall Diameter "A" (mm)	Stem Diameter "B" (mm)	Hole "C" (mm)	Maximum Voltage [Um] (kV rms)
EPISF-A	76	110	38	Diameter 14 x 21 long slotted	72
EPISF-B	127	160	38	Diameter 18 x 27 long slotted	300
EPISF-C	225	265	38	Diameter 18 x 27 long slotted	420

The following clamps shall be tested in accordance with section 3 of this standard:

- EPISF-B

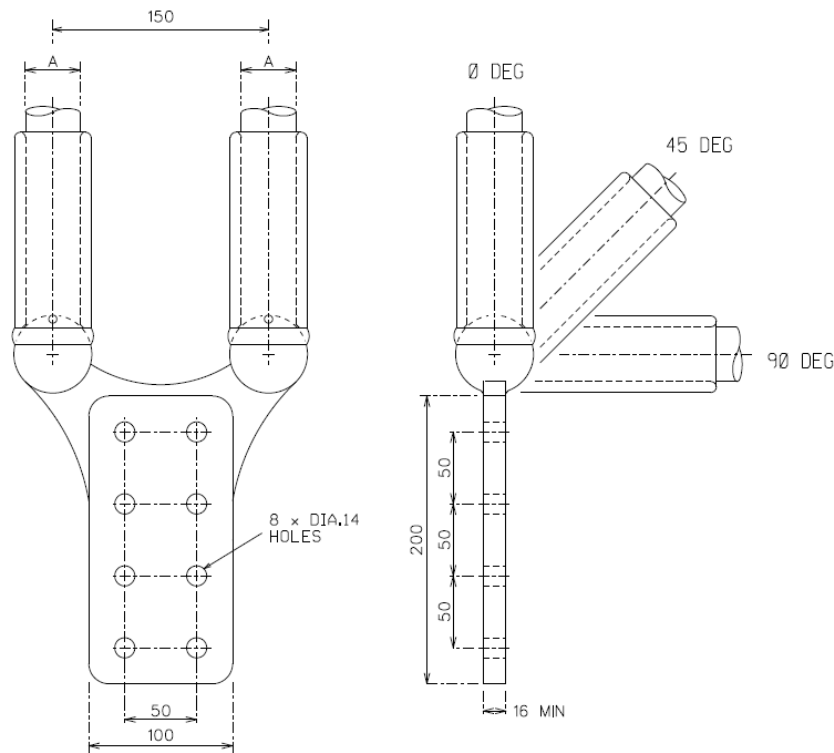

Figure A.29: EYCT Clamp

Table A.29: Type EYCT Clamps

Type Designation	Equipment Terminal (mm)	Conductor Diameter "A" (mm)	Centre Spacing (mm)	Angle of off-set (degrees)	Normal Rated Current @ 90°C [A rms]	Maximum Voltage [Um] (kV rms)	1s Short-Circuit Current Withstand Rating with ES Spacer [kA rms]
EYCT-A	8 Bolt Pad to SANS 62271-301	2 x 38.3	150	0°	2700	420	63
EYCT-B	8 Bolt Pad to SANS 62271-301	2 x 38.3	150	45°	2700	420	63
EYCT-C	8 Bolt Pad to SANS 62271-301	2 x 38.3	150	90°	2700	420	63
EYCT-D	8 Bolt Pad to SANS 62271-301	2 x 26.5	150	0°	1700	300	50
EYCT-E	8 Bolt Pad to SANS 62271-301	2 x 26.5	150	45°	1700	300	50
EYCT-F	8 Bolt Pad to SANS 62271-301	2 x 26.5	150	90°	1700	300	50

**Note:** All clamps shall be able to withstand 31.5kA rms for 1 second without the non-current carrying ES spacer butted up to the crimped tube.

The following clamps shall be tested in accordance with section 3 of this standard:

- EYCT-B

**ESKOM COPYRIGHT PROTECTED**

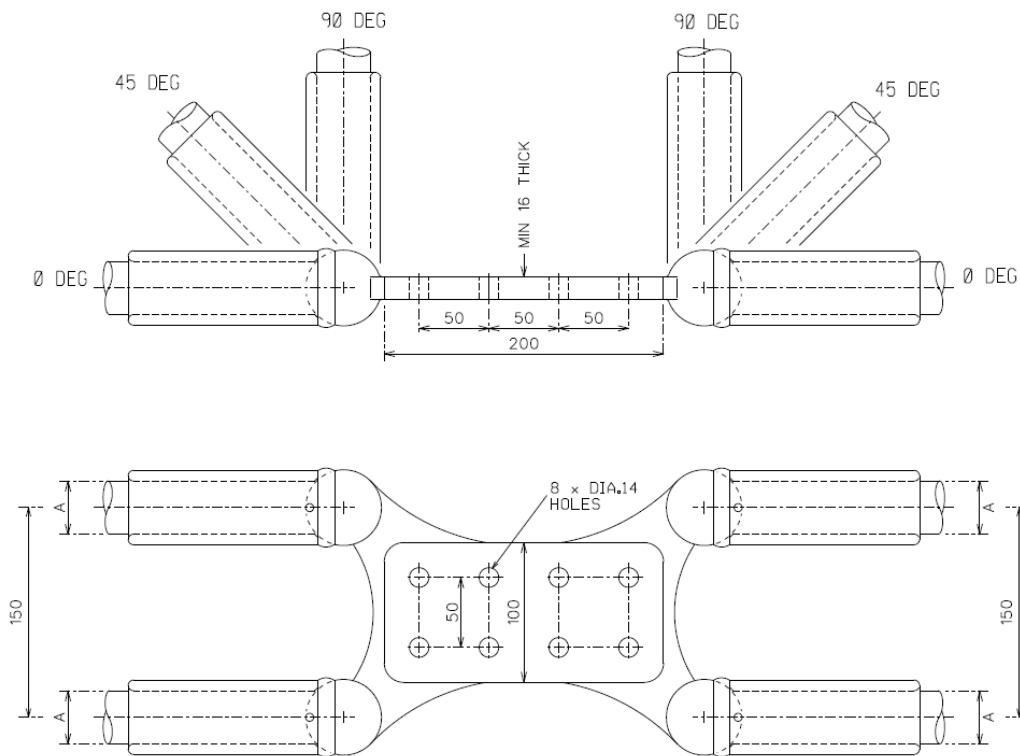

**Figure A.30: EYCDT Clamp**

**Table A.30: Type EYCDT Clamps**

Type Designation	Equipment Terminal (mm)	Conductor Diameter "A" (mm)	Centre Spacing (mm)	Angle of off-set (degrees)	Normal Rated Current @ 90°C [A rms]	Maximum Voltage [Um] (kV rms)	1s Short-Circuit Current Withstand Rating with ES Spacer [kA rms]
EYCDT-A	8 Bolt Pad to SANS 62271-301	4 x 38.3	150	0°	2700	420	63
EYCDT-B	8 Bolt Pad to SANS 62271-301	4 x 38.3	150	45°	2700	420	63
EYCDT-C	8 Bolt Pad to SANS 62271-301	4 x 38.3	150	90°	2700	420	63
EYCDT-D	8 Bolt Pad to SANS 62271-301	4 x 26.5	150	0°	1700	300	50
EYCDT-E	8 Bolt Pad to SANS 62271-301	4 x 26.5	150	45°	1700	300	50
EYCDT-F	8 Bolt Pad to SANS 62271-301	4 x 26.5	150	90°	1700	300	50

**Note:** All clamps shall be able to withstand 31.5kA rms for 1 second without the non-current carrying ES spacer butted up to the crimped tube.

The following clamps shall be tested in accordance with section 3 of this standard:

- EYCDT-B

**ESKOM COPYRIGHT PROTECTED**

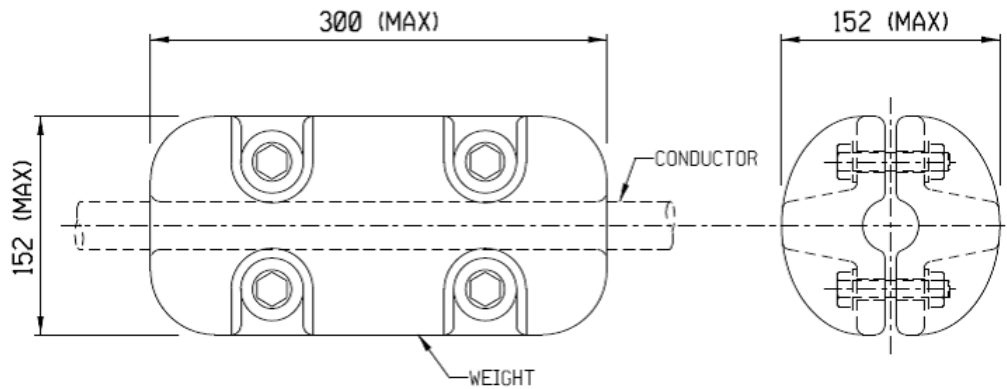

Figure A.31: ECJW Clamp

Table A.31: Type ECJW Clamps

Type Designation	Conductor Diameter (mm)	Mass (kg)	Application	Maximum Voltage [Um] (kV rms)
ECJW-A	38.3	25	Single conductor	300
			Twin Conductor 150mm separation	420
			Triple Conductor 165mm separation	500
ECJW -B	26.5	25	Single conductor	145
			Twin Conductor 150mm separation	300

The following clamps shall be tested in accordance with section 3 of this standard:

- ECJW-A

**Annex B – Technical Schedules A and B**

Add appendix detail here or remove if not required.

**SCHEDULE A: ESKOM'S PARTICULARS REQUIREMENTS****SCHEDULE B: GUARANTEES AND TECHNICAL PARTICULARS OF CLAMPS OFFERED**

ITEM NO	CLAUSE	DESCRIPTION	UNIT	SCHEDULE A	SCHEDULE B
		<b>GENERAL REQUIREMENTS</b>			
<b>1</b>	<b>3.1.1</b>	<b>SERVICE CONDITIONS</b>			
1.1		Altitude	m	1800	
1.2		Ambient air temperature			
		a) Maximum	°C	-10	
		b) Minimum	°C	+45	
		c) Daily average	°C	30	
		d) Yearly average	°C	20	
1.3		Maximum solar radiation	W/m <sup>2</sup>	1100	
1.4		Wind speed	m/s	0.44	
<b>2</b>	<b>3.3.1</b>	<b>ALLOY</b>			
2.1		Type of alloy		Aluminium alloy	
2.2		Alloy designation		As specified	
2.3		Chemical composition of alloy		As specified	
<b>3</b>	<b>3.3.3</b>	<b>BOLTED CLAMPS</b>			
3.1		Material			
		a) Bolt	-	As specified	
		b) Nut	-	As specified	
		c) Washer	-	As specified	
3.2		Grade of steel fasteners			
		a) Bolt	Grade	4.6 / 8.8	
		b) Nut	Grade	4.6 / 8.8	
		c) Washer	Grade	A	
3.3		Type of washer	-	Plain	

**ESKOM COPYRIGHT PROTECTED**

ITEM NO	CLAUSE	DESCRIPTION	UNIT	SCHEDULE A	SCHEDULE B
3.4		Corrosion resistance of bolts, nuts and washers	-	Yes	
3.5		Tensile strength of bolts (min.)	MPa	480	
3.6		Bolt torque levels			
		a) Recommended	Nm	-	
		b) Minimum	Nm	-	
		c) ultimate	Nm	-	
3.7		Bolt torque stamped on clamp	-	Yes	
<b>4</b>	<b>3.3.4</b>	<b>COMPRESSION CLAMPS</b>			
4.1		Alloy of compression sleeve	-	-	
4.2		Recommended compression force	kN	-	
4.3		Number of compressions per joint	-	-	
4.4		Diameter of drilled hole	mm	4	
4.5		Die size marking on compression sleeve	-	Yes	
4.6		Type of grease	-	-	
4.7		Compression sleeves pre-greased and sealed before despatch	-	Yes	
<b>5</b>	<b>3.3.4</b>	<b>COMPRESSION TOOLS (information)</b>			
		N.B. Set = Compression head complete with dies and hose (minimum)			
5.1		Manufacturer	-	-	
5.2		Type	-	-	
5.3		Manual of operation and maintenance	-	Yes	
5.4		Equipment to be supplied with each set (Contractor to list)	-	Yes	
5.5		<b>Compression Head</b>			
		a) Maximum operating temperature	MPa	-	
		b) Recommended compressor	-	-	
		c) Hand pump supplied	-	Yes	
5.6		<b>Dies</b>			

**ESKOM COPYRIGHT PROTECTED**

ITEM NO	CLAUSE	DESCRIPTION	UNIT	SCHEDULE A	SCHEDULE B
		Material	-	-	
		Die size	mm	-	
		Number of operations during lifespan	-	-	
		Test gauges	-	Yes	
<b>6</b>	<b>3.3.5</b>	<b>WELDING</b>			
6.1		Method of welding	-	Tungsten or metal inert-gas	
6.2		Proof of accreditation of welder	-	Yes	
6.3		Welding procedure	-	Yes	
<b>7</b>	<b>3.3.7</b>	<b>ELECTRICAL JOINT COMPOUND</b>			
7.1		Trade name	-	-	
7.2		Type of compound	-	-	
7.3		Properties of compound			
		Drop point	°C	>90	
		Flash point	°C	≥140	
		Oil separation	-	≤ 1% at 100°C for 4 hours	
7.4		Temperature rating			
		Maximum rated normal current	A	-	
		Maximum rated short-circuit current	kA	-	
7.5		Source of supply	-	-	
7.6		Expected lifespan	-	-	
		<b>SPECIFIC CLAMP REQUIREMENTS</b>			
<b>8</b>	<b>Annex A</b>	<b>TYPE</b>			
8.1		Type designation	-	As specified	
8.2		Drawing number	-	Yes	

ITEM NO	CLAUSE	DESCRIPTION	UNIT	SCHEDULE A	SCHEDULE B
<b>9</b>	<b>Annex A</b>	<b>ELECTRICAL RATINGS</b>			
9.1		Rated system voltage	kV	As specified	
9.2		Rated normal current at 90°C	A	As specified	
9.3		Rated short-circuit withstand current	kA	As specified	
9.4		Duration of short-circuit withstand current	s	As specified	
<b>10</b>	<b>Annex A</b>	<b>OVERALL DIMENSIONS</b>			
10.1		Dimensions	mm	-	
10.2		Mass	kg	-	
<b>11</b>	<b>3.3.3</b>	<b>BOLTED CLAMPS</b>			
11.1		Bolt size	mm	-	
11.2		Number of saddles per clamp	-	-	
<b>12</b>	<b>3.3.4</b>	<b>COMPRESSION SLEEVES</b>			
12.1		Inner diameter	mm	-	
12.2		Tolerance of inner diameter	-	-	
12.3		Wall thickness	mm	-	
12.4		Tolerance of wall thickness	mm	-	
<b>13</b>	<b>Annex A</b>	<b>SPACERS</b>			
13.1		Compression forces	kN	As specified	
<b>14</b>	<b>3.12</b>	<b>DOCUMENTS TO BE SUBMITTED</b>			
14.1		Completed technical schedules B for each clamp type	-	Yes	
14.2		Drawing for each type of clamp	-	Yes	
14.3		Manual(s) for handling, storage, installation and inspections	-	Yes	
14.4		Welding procedure	-	Yes	
14.5		Proof of accreditation of welder	-	Yes	

**ESKOM COPYRIGHT PROTECTED**

ITEM NO	CLAUSE	DESCRIPTION	UNIT	SCHEDULE A	SCHEDULE B
14.6		List of all applicable type test certificates and reports for each clamp type	-	Yes	
14.7	3.4.2	Copies of applicable type test certificates and reports			Report no:
		a) Heat (Current)-Cycle test	-	Yes	
		b) Temperature rise test	-	Yes	
		c) Corona test	-	Yes	
		d) RIV test	-	Yes	
		e) Short-circuit withstand test	-	Yes	
		f) Bolt-tightening torque test	-	Yes	
		g) Slip/Pull-out strength test	-	Yes	
		h) Cantilever strength of bus supports test	-	Yes	
14.8	3.4.4	Copies of all applicable type test certificates and reports for spacers			Report no:
		a) Corona test	-	Yes	
		b) RIV test	-	Yes	
		c) Longitudinal slip test	-	Yes	
		d) Torsional slip test	-	Yes	
		e) Breakaway bolt test	-	Yes	
		f) Clamp bolt tightening test	-	Yes	
		g) Simulated short-circuit current test	-	Yes	
		h) Compression and Tension tests	-	Yes	

**Note:** Items 8 – 14.8 (except 14.3-14.5) to be completed in respect of each clamp or spacer type offered.

**Annex C – Deviation Sheet to be completed for Tenders**

<b>Product Description</b>			
<b>Eskom SAP Number</b>		<b>Product (item) code</b>	
<b>Latest Specification Applicable (i.e. Eskom D-DT # &amp; Rev #)</b>			

This deviation schedule is to be completed by all potential suppliers or manufacturers **whether or not a deviation** exists from the Eskom requirements. All deviations offered which does not conform to the latest standard applicable shall be listed below with reasons for the deviation. **Please indicate clearly.**

<b>Clause</b>	<b>Proposed Deviation</b>	<b>Reason</b>

<b>Product Manufacturer</b>		<b>Deviation Exists</b>		<b>Yes</b>		<b>No</b>
<b>Supplier to Eskom</b>		<b>Supplier Representative</b>				
<b>Supplier Representative Signature</b>		<b>Date</b>				

Note: All fields are mandatory and must be completed accordingly.

**ESKOM COPYRIGHT PROTECTED**