



BID DESCRIPTION: APPOINTMENT OF ONE SERVICE PROVIDER FOR SUPPLY AND DELIVERY OF TICKETING MATERIAL (PITIX ROLLS, ITIX ROLLS AND RIBBONS) ON AS AND WHEN BASIS FOR A PERIOD OF 36 MONTHS AT PRASA IN THE EASTERN CAPE REGION (ECR)	 prasa <small>PASSENGER RAIL AGENCY OF SOUTH AFRICA</small>
BID NUMBER: ECR/RAIL/ICT/01/2026	

BID NUMBER: *ECR/RAIL/ICT/01/2026*

REQUEST FOR PROPOSAL (RFP) FOR THE APPOINTMENT OF ONE SERVICE PROVIDER FOR SUPPLY AND DELIVERY OF TICKETING MATERIAL (PITIX ROLLS, ITIX ROLLS AND RIBBONS) ON AS AND WHEN BASIS FOR A PERIOD OF 36 MONTHS AT PRASA IN THE EASTERN CAPE REGION (ECR)

CLOSING DATE	13 JULY 2026
CLOSING TIME	12H00
BRIEFING SESSION	N/A
BID DOCUMENTS DELIVERY ADDRESS	PASSENGER RAIL AGENCY OF SOUTH AFRICA NO. 8 STATION STREET STATION BUILDING EAST LONDON STATION EAST LONDON
BIDDER NAME

BID DESCRIPTION: APPOINTMENT OF ONE SERVICE PROVIDER FOR SUPPLY AND DELIVERY OF TICKETING MATERIAL (PITIX ROLLS, ITIX ROLLS AND RIBBONS) ON AS AND WHEN BASIS FOR A PERIOD OF 36 MONTHS AT PRASA IN THE EASTERN CAPE REGION (ECR)	
BID NUMBER: ECR/RAIL/ICT/01/2026	

Disclaimer

This document is provided solely for the purpose set out in this RFP and is not intended to form any part or basis of any investment decision by Bidders. The recipient should not consider the document as an investment recommendation by PRASA or any of its advisers.

Each person to whom this document (and other later documents) is made available must make his own independent assessment of the Project after making such investigation and taking such professional advice as he/she or it deems necessary. Neither the receipt of this document or any related document by any person, nor any information contained in the documents or distributed with them or previously or subsequently communicated to any Bidder or its advisers, is to be taken as constituting the giving of an investment advice by PRASA or its advisers.

Whilst reasonable care has been taken in preparing this RFP and other documents, they do not purport to be comprehensive or true and correct. Neither PRASA nor any of its advisers accept any liability or responsibility for the adequacy, accuracy, or completeness of any of the information or opinions stated in any document.

They acquaint themselves with this RFP and take note that no representation or warranty, express or implied, is or will be given by PRASA, or any of its officers, employees, agents or advisers with respect to the information or opinions contained in any document or on which any document is based. Any liability in respect of such representations or warranties, howsoever arising is hereby expressly disclaimed.

If any recipient, or its employees, advisers or agents make or offer to make any gift to any of the employees of PRASA or consultant to PRASA on the RFP either directly or through an intermediary then such recipient, Bidder will be disqualified forthwith from participating in the RFP.

Each recipient of this RFP agrees to keep confidential any information of a confidential nature which may be contained in the information provided by PRASA, or any of its officers, employees, agents or advisers (the "Confidential Information Provided"). The Confidential Information provided may be made available to Bidder's subcontractors, employees and professional advisers who are directly involved in the appraisal of such information (who must be made aware of the obligation of confidentiality) but shall

BID DESCRIPTION: APPOINTMENT OF ONE SERVICE PROVIDER FOR SUPPLY AND DELIVERY OF TICKETING MATERIAL (PITIX ROLLS, ITIX ROLLS AND RIBBONS) ON AS AND WHEN BASIS FOR A PERIOD OF 36 MONTHS AT PRASA IN THE EASTERN CAPE REGION (ECR)	
BID NUMBER: ECR/RAIL/ICT/01/2026	

not, either in the whole or in part, be copied, reproduced, distributed or otherwise made available to any other party in any circumstances without the prior written consent of PRASA, nor may it be used for any other purpose than that for which it is intended.

These requirements do not apply to any information, which is or becomes publicly available or is shown to have been made available (otherwise than through a breach of a confidentiality obligation). Bidders, Key Contractors and their constituent members, agents and advisers, may be required to sign confidentiality Contracts/undertakings (in such form as PRASA may require from time to time).

All Confidential Information Provided (including all copies thereof) remains the property of PRASA and must be delivered to PRASA on demand. Further, by receiving this RFP each Bidder and each of its members agree to maintain its submission in Bid to this RFP confidential from third parties other than PRASA and its officials, officers and advisers who are required to review the same for the purpose of procurement of the RFP.

Any recipient residing outside the Republic of South Africa is urged to familiarise themselves with and to observe any regulatory requirements relevant to the proposed transaction (whether these derive from a regulatory authority within or outside the Republic of South Africa).

Any requirement set out in this RFP regarding the content of a response to the RFP is stipulated for the sole benefit of PRASA, and serves as expressly stated to the contrary, may be waived at its discretion at any stage in the procurement process.

PRASA is not committed to any course of action as a result of its issuance of this RFP and/or its receipt of a Proposal in response to it. Please note that PRASA reserves the right to:

- Modify the RFP's goods / service(s) / works and request Bidders to re-bid on any changes;
- Withdraw, amend the RFP at any time without prior notice and liability to compensate or reimburse any bidder;
- Reject any Proposal which does not conform to instructions and specifications which are detailed herein;
- Disqualify Proposals submitted after the stated submission deadline;

BID DESCRIPTION: APPOINTMENT OF ONE SERVICE PROVIDER FOR SUPPLY AND DELIVERY OF TICKETING MATERIAL (PITIX ROLLS, ITIX ROLLS AND RIBBONS) ON AS AND WHEN BASIS FOR A PERIOD OF 36 MONTHS AT PRASA IN THE EASTERN CAPE REGION (ECR)	
BID NUMBER: ECR/RAIL/ICT/01/2026	

- Call a bidder to provide additional documents which PRASA may require which have not been submitted to PRASA;
- Withdraw the RFP on good cause shown;
- Award a contract in connection with this Proposal at any time after the RFP's closing date;
- Make no award at all;
- Validate any information submitted by Bidders in response to this bid. This would include, but is not limited to, requesting the Bidders to provide supporting evidence. By submitting a bid, Bidders hereby irrevocably grant the necessary consent to PRASA to do so;
- Request annual financial statements prepared and signed off by a professional accountant or other documentation for the purposes of a due diligence exercise; and/or
- Not accept any changes or purported changes by the Bidder to the bid rates after the closing date and/or after the award of the business, unless the contract specifically provided for it.

To adopt any proposal made by any bidder at any time and to include such proposal in any procurement document which may or may not be made available to other bidders.

All costs and expenses incurred by Bidders in submitting responses to this RFP shall be borne by the Bidders and PRASA shall not be liable for any costs or expenses whatsoever or any claim for reimbursement of such costs or expenses.

Should a contract be awarded on the strength of information furnished by the Bidder, which after conclusion of the contract, is proved to have been incorrect, PRASA reserves the right to cancel the contract and/or place the Bidder on PRASA's list of Restricted Suppliers.

PRASA reserves the right to negotiate market-related price with the bidder scoring the highest points or cancel the bid; if the bidder does not agree to a market related price, negotiate a market related price with the bidder scoring the second highest points or cancel the bid; if the bidder scoring the second highest points does not agree to a market related price, negotiate a market related price with the bidder scoring the third highest points or cancel the bid. If the market related price is not agreed as envisaged in this paragraph, PRASA will cancel the bid.

BID DESCRIPTION: APPOINTMENT OF ONE SERVICE PROVIDER FOR SUPPLY AND DELIVERY OF TICKETING MATERIAL (PITIX ROLLS, ITIX ROLLS AND RIBBONS) ON AS AND WHEN BASIS FOR A PERIOD OF 36 MONTHS AT PRASA IN THE EASTERN CAPE REGION (ECR)	
BID NUMBER: ECR/RAIL/ICT/01/2026	

PRASA reserves the right to negotiating the Best and Final Offer (BAFO) with selected Bidders where none of the Proposals meet RFP requirement, are affordable and demonstrate value for money and there is no clear preferred response to the RFP.

PRASA will not reimburse any Bidder for any preparatory costs or other work performed in connection with its Proposal, whether or not the Bidder is awarded a contract.

BID DESCRIPTION: APPOINTMENT OF ONE SERVICE PROVIDER FOR SUPPLY AND DELIVERY OF TICKETING MATERIAL (PITIX ROLLS, ITIX ROLLS AND RIBBONS) ON AS AND WHEN BASIS FOR A PERIOD OF 36 MONTHS AT PRASA IN THE EASTERN CAPE REGION (ECR)	 prasa <small>PASSENGER RAIL AGENCY OF SOUTH AFRICA</small>
BID NUMBER: ECR/RAIL/ICT/01/2026	

SCHEDULE OF BID DOCUMENTS

SECTION NO	PAGE
SECTION 1 : NOTICE TO BIDDERS	
<u>1 INVITATION TO BID</u>	1
<u>2 FORMAL BRIEFING</u>	14
<u>4 PROPOSAL SUBMISSION</u>	14
<u>5 DELIVERY INSTRUCTIONS FOR RFP</u>	15
<u>6 BROAD-BASED BLACK ECONOMIC EMPOWERMENT AND SOCIO-ECONOMIC OBLIGATIONS</u>	15
<u>7 COMMUNICATION</u>	18
<u>8 CONFIDENTIALITY</u>	18
<u>9 INSTRUCTIONS FOR COMPLETING THE RFP</u>	19
<u>10 RFP TIMETABLE</u>	21
11 LEGAL COMPLIANCE	22
<u>12 NATIONAL TREASURY’S CENTRAL SUPPLIER DATABASE</u>	22
<u>13 TAX COMPLIANCE</u>	22
<u>14 PROTECTION OF PERSONAL DATA</u>	23
<u>SECTION 2 : BACKGROUND, OVERVIEW AND SCOPE OF REQUIREMENTS</u>	24
<u>1 INTRODUCTION AND BACKGROUND</u>	24
<u>2 OVERVIEW</u>	24
<u>3 KEY OBJECTIVES OF THE RFP</u>	25
<u>4 SCOPE OF WORK</u>	25
<u>5 EVALUATION METHODOLOGY</u>	26
6 POST TENDER NEGOTIATIONS (IF APPLICABLE)	39

BID DESCRIPTION: APPOINTMENT OF ONE SERVICE PROVIDER FOR SUPPLY AND DELIVERY OF TICKETING MATERIAL (PITIX ROLLS, ITIX ROLLS AND RIBBONS) ON AS AND WHEN BASIS FOR A PERIOD OF 36 MONTHS AT PRASA IN THE EASTERN CAPE REGION (ECR)	 prasa <small>PASSENGER RAIL AGENCY OF SOUTH AFRICA</small>
BID NUMBER: ECR/RAIL/ICT/01/2026	

7 BEST AND FINAL OFFER 39

8 FINAL CONTRACT AWARD 39

9 FAIRNESS AND TRANSPARENCY 39

SECTION 3 : PRICING AND DELIVERY SCHEDULE 40

1 PRICING 40

2 DISCLOSURE OF PRICES QUOTED 41

3 PERFROMANCE AND BID BONDS (WHERE APPLICABLE) 41

4 OWNERSHIP OF DESIGN 41

5 SERVICE LEVELS 41

6 TOTAL COST OF OWNERSHIP AND CONTINUOUS IMPROVEMENT INITIATIVES 42

7 FINANCIAL STABILITY 43

8 VALIDITY OF RETURNABLE DOCUMENTS44

9 CERTIFICATE OF ACQUAINTANCE WITH RFP TERMS AND CONDITIONS 45

10. GENERAL CONDITIONS 47

11 CONDITIONS OF TENDER 52

BID DESCRIPTION: APPOINTMENT OF ONE SERVICE PROVIDER FOR SUPPLY AND DELIVERY OF TICKETING MATERIAL (PITIX ROLLS, ITIX ROLLS AND RIBBONS) ON AS AND WHEN BASIS FOR A PERIOD OF 36 MONTHS AT PRASA IN THE EASTERN CAPE REGION (ECR)	 prasa <small>PASSENGER RAIL AGENCY OF SOUTH AFRICA</small>
BID NUMBER: ECR/RAIL/ICT/01/2026	

LIST OF BID DOCUMENTS

INVITATION TO BID PART A	Form A
TERMS AND CONDITIONS FOR BIDDING PART B	Form B
TENDER FORM (PRICING SCHEDULE)	Form C
STATEMENT OF WORK SUCCESSFULLY CARRIED OUT BY BIDDER	Form D
SECURITY SCREENING FORM	Form E
ACKNOWLEDGEMENT	Form F
SBD 4 BIDDER'S DISCLOSURE	
SBD 5 THE NATIONAL INDUSTRIAL PARTICIPATION PROGRAMME	
SBD 6.1 PREFERENCE POINTS CLAIM FORM IN TERMS OF THE PREFERENTIAL PROCUREMENT REGULATIONS 2022	

BID DESCRIPTION: APPOINTMENT OF ONE SERVICE PROVIDER FOR SUPPLY AND DELIVERY OF TICKETING MATERIAL (PITIX ROLLS, ITIX ROLLS AND RIBBONS) ON AS AND WHEN BASIS FOR A PERIOD OF 36 MONTHS AT PRASA IN THE EASTERN CAPE REGION (ECR)	 prasa <small>PASSENGER RAIL AGENCY OF SOUTH AFRICA</small>
BID NUMBER: ECR/RAIL/ICT/01/2026	

1 LIST OF ANNEXURES TO THE RFP

PRICING SCHEDULE	ANNEXURE A
RFP CLARIFICATION FORM	ANNEXURE B
RFP APPENDICES	ANNEXURE C

BID DESCRIPTION: APPOINTMENT OF ONE SERVICE PROVIDER FOR SUPPLY AND DELIVERY OF TICKETING MATERIAL (PITIX ROLLS, ITIX ROLLS AND RIBBONS) ON AS AND WHEN BASIS FOR A PERIOD OF 36 MONTHS AT PRASA IN THE EASTERN CAPE REGION (ECR)	 prasa <small>PASSENGER RAIL AGENCY OF SOUTH AFRICA</small>
BID NUMBER: ECR/RAIL/ICT/01/2026	

2 ACRONYMS

BBBEE	Broad Based-Black Economic Empowerment
CIDB	Construction Industries Development Board
DTiC	The Department of Trade and Industry and Competition
PPPFA	Preferential Procurement Policy Framework Act 5 of 2000 (as amended from time to time)
PFMA	Public Finance Management Act No.1 of 1999 (as amended from time to time)
PRASA	Passenger Rail Agency of South Africa
RFP	Request for Proposal
SANAS	South African National Accreditation System

BID DESCRIPTION: APPOINTMENT OF ONE SERVICE PROVIDER FOR SUPPLY AND DELIVERY OF TICKETING MATERIAL (PITIX ROLLS, ITIX ROLLS AND RIBBONS) ON AS AND WHEN BASIS FOR A PERIOD OF 36 MONTHS AT PRASA IN THE EASTERN CAPE REGION (ECR)	 prasa <small>PASSENGER RAIL AGENCY OF SOUTH AFRICA</small>
BID NUMBER: ECR/RAIL/ICT/01/2026	

3 INTERPRETATION

In this RFP, unless inconsistent with or otherwise indicated by the context –

- 3.1 headings have been inserted for convenience only and should not be taken into account in interpreting the RFP;
- 3.2 any reference to one gender shall include the other gender;
- 3.3 words in the singular shall include the plural and vice versa;
- 3.4 any reference to natural persons shall include legal persons and vice versa;
- 3.5 words defined in a specific clause have the same meaning in all other clauses of the RFP, unless the contrary is specifically indicated;
- 3.6 any reference to the RFP, schedule or appendix, shall be construed as including a reference to any RFP, schedule or appendix amending or substituting that RFP, schedule or appendix;
- 3.7 the schedules, appendices and Briefing Notes issued pursuant to this RFP, form an indivisible part of the RFP and together with further clarifying and amending information provided by PRASA, constitute the body of RFP documentation which must be complied with by Bidders;
- 3.8 in the event of any inconsistency between this RFP or other earlier information published with regard to the Project, the information in this RFP shall prevail; and
- 3.9 this RFP shall be governed by and applied in accordance with South African law.

<p>BID DESCRIPTION: APPOINTMENT OF ONE SERVICE PROVIDER FOR SUPPLY AND DELIVERY OF TICKETING MATERIAL (PITIX ROLLS, ITIX ROLLS AND RIBBONS) ON AS AND WHEN BASIS FOR A PERIOD OF 36 MONTHS AT PRASA IN THE EASTERN CAPE REGION (ECR)</p>	
<p>BID NUMBER: ECR/RAIL/ICT/01/2026</p>	

4 DEFINITIONS

In this RFP and in any other project documents (as defined below) which so provides, the following words and expressions shall have the meaning assigned to them below and cognate expressions shall have a corresponding meaning, unless inconsistent with the context:

- 4.1 “Accounting Authority” means the Board of PRASA or a controlling body and that Board or controlling body is the accounting authority of PRASA or a person designated as an accounting authority under the PFMA;
- 4.2 “Contract” means the Contract to be entered between PRASA and the successful Bidder for the provision of the *services* procured in this RFP;
- 4.3 “Bid” means the Bid(s) to the RFP submitted by Bidder(s);
- 4.4 “Bidders Briefing Session” means the compulsory briefing session to be held at the offices of PRASA, in order to brief the Bidders about this tender;
- 4.5 “Black Enterprise” means an enterprise that is at least 51% beneficially owned by Black People and in which Black People have substantial Management Control. Such beneficial ownership may be held directly or through other Black Enterprises;
- 4.6 “Black Equity” means the voting equity held by Black People from time to time;
- 4.7 “Black People” has the same meaning as ascribed to the Broad-Based Black Economic Empowerment Act, 2003, as amended;
- 4.8 “Black Woman” means African, Coloured and Indian South Africa Female citizen;
- 4.9 “Briefing Note” means any correspondence to Bidders issued by the PRASA;
- 4.10 “Business Day” means any day except a Saturday, Sunday or public holiday in South Africa;
- 4.11 “Bidders” means individuals, organisations or consortia that have been submitted responses to the RFP in respect of the tender;
- 4.12 “Consortium” means any group of persons or firms jointly submitting a Bid as Bid to this RFP and “Consortia” means more than one Consortium;
- 4.13 “Contractor” the successful Bidders who has signed a Contract with PRASA in terms of this RFP.
- 4.14 “Closing Date” means the closing date for submission of bids/ Proposals by Bidders which is **13th July 2026;**

BID DESCRIPTION: APPOINTMENT OF ONE SERVICE PROVIDER FOR SUPPLY AND DELIVERY OF TICKETING MATERIAL (PITIX ROLLS, ITIX ROLLS AND RIBBONS) ON AS AND WHEN BASIS FOR A PERIOD OF 36 MONTHS AT PRASA IN THE EASTERN CAPE REGION (ECR)	 prasa <small>PASSENGER RAIL AGENCY OF SOUTH AFRICA</small>
BID NUMBER: ECR/RAIL/ICT/01/2026	

4.15 “Project” means this project for THE APPOINTMENT OF ONE SERVICE PROVIDER FOR SUPPLY AND DELIVERY OF TICKETING MATERIAL (PITIX ROLLS, ITIX ROLLS AND RIBBONS) ON AS AND WHEN BASIS FOR A PERIOD OF 36 MONTHS AT PRASA IN THE EASTERN CAPE REGION (ECR)

4.16 “RFP” means the Request for Proposal issued by PRASA for this tender; and

4.17 “Scope of Work” means the scope of work for this project as detailed out in the RFP technical specifications.

BID DESCRIPTION: APPOINTMENT OF ONE SERVICE PROVIDER FOR SUPPLY AND DELIVERY OF TICKETING MATERIAL (PITIX ROLLS, ITIX ROLLS AND RIBBONS) ON AS AND WHEN BASIS FOR A PERIOD OF 36 MONTHS AT PRASA IN THE EASTERN CAPE REGION (ECR)	 prasa <small>PASSENGER RAIL AGENCY OF SOUTH AFRICA</small>
BID NUMBER: ECR/RAIL/ICT/01/2026	

SECTION 1
NOTICE TO BIDDERS

1 INVITATION TO BID

You are hereby invited to submit a bid to meet the requirements of the Passenger Rail Agency of South Africa. Responses to this RFP [hereinafter referred to as a **Bid** or a **Proposal**] are requested from persons, companies, close corporations, or enterprises [hereinafter referred to as an **entity, Bidder**].

BID DESCRIPTION	REQUEST FOR PROPOSAL (RFP) FOR THE APPOINTMENT OF ONE SERVICE PROVIDER FOR SUPPLY AND DELIVERY OF TICKETING MATERIAL (PITIX ROLLS, ITIX ROLLS AND RIBBONS) ON AS AND WHEN BASIS FOR A PERIOD OF 36 MONTHS AT PRASA IN THE EASTERN CAPE REGION (ECR)
BID ADVERT	This RFP may be downloaded directly from National Treasury's e-Tender Publication Portal at www.etenders.gov.za free of charge. With effect from 12 June 2026
EMAIL ADDRESS FOR COMMUNICATION	Once Bidders download the RFP off the Portal, they are required to send their contact details to the following address: (Simnikiwe.Nqulo@prasa.com) This is to ensure that any required communication in relation to this RFP reaches those intending to respond. Furthermore, any addenda to the RFP or clarifications will be published on the e-tender portal. Bidders are required to check the e-tender portal prior to finalising their bid submissions for any changes or clarifications to the RFP. Prasa will not be held liable if Bidders do not receive the latest information regarding this RFP with the possible consequence of either being disadvantaged or disqualified as a result thereof
ISSUE DATE	12 June 2026
COLLECTION DATE DEADLINE (if applicable)	N/A
COMPULSORY BRIEFING SESSION	N/A
CLOSING DATE	13 JULY 2026 @12H00PM

BID DESCRIPTION: APPOINTMENT OF ONE SERVICE PROVIDER FOR SUPPLY AND DELIVERY OF TICKETING MATERIAL (PITIX ROLLS, ITIX ROLLS AND RIBBONS) ON AS AND WHEN BASIS FOR A PERIOD OF 36 MONTHS AT PRASA IN THE EASTERN CAPE REGION (ECR)	 prasa <small>PASSENGER RAIL AGENCY OF SOUTH AFRICA</small>
BID NUMBER: ECR/RAIL/ICT/01/2026	

	<p>Bidders must ensure that bids are delivered timeously to the correct address.</p> <p>As a rule, if a bid is late or delivered to the incorrect address, it will not be accepted for consideration.</p>
VALIDITY PERIOD	90 Working Days from Closing Date Bidders are to note that they may be requested to extend the validity period of their bid, at the same terms and conditions, if the internal evaluation process has not been finalised within the validity period.
CLOSING DATE FOR QUESTIONS	23 June 2026
CLOSING DATE FOR RESPONSES	26 June 2026
CONTACT PERSON	Simnikiwe Nqulo

Any additional information or clarification will be emailed to all Bidders, if necessary.

2 FORMAL BRIEFING

A formal briefing session will not be held but should Bidders have specific queries they should email these to the PRASA employee(s) indicated in paragraph 6 *[Communication]* below:

- 2.1 Clarifications will be issued to all Bidders to this RFP utilizing the contact details provided at receipt of the responses to the RFP documentation, after submission to the authorised representative.
- 2.2 Bidders / Bidders are requested to promptly confirm receipt of any clarifications sent to them.
- 2.3 Bidders / Bidders must ensure responses to the clarifications are received on or before the deadline date stated.

BID DESCRIPTION: APPOINTMENT OF ONE SERVICE PROVIDER FOR SUPPLY AND DELIVERY OF TICKETING MATERIAL (PITIX ROLLS, ITIX ROLLS AND RIBBONS) ON AS AND WHEN BASIS FOR A PERIOD OF 36 MONTHS AT PRASA IN THE EASTERN CAPE REGION (ECR)	 prasa <small>PASSENGER RAIL AGENCY OF SOUTH AFRICA</small>
BID NUMBER: ECR/RAIL/ICT/01/2026	

3 PROPOSAL SUBMISSION OF RFP RESPONSE

Proposal Responses should be submitted to PRASA in a sealed envelope addressed as follows:

The Secretariat / Tender Office

RFP No: **ECR/RAIL/ICT/01/2026**

Description of Bid **APPOINTMENT OF ONE SERVICE PROVIDER FOR SUPPLY AND DELIVERY OF TICKETING MATERIAL (PITIX ROLLS, ITIX ROLLS AND RIBBONS) ON AS AND WHEN BASIS FOR A PERIOD OF 36 MONTHS AT PRASA IN THE EASTERN CAPE REGION (ECR)**

Closing date and time: **13 JULY 2026 AT 12H00 PM**

Closing address **NO 8 STATION STREET, STATION BUILDING, EAST LONDON EAST LONDON STATION, EAST LONDON 5200**

4 DELIVERY INSTRUCTION FOR RFP

Delivery of Bid

The Bid envelopes should be deposited in the PRASA tender box which is located at the below address and should be addressed as follows:

**Closing address: Passenger Rail Agency of South Africa,
The Secretariat /Tender Office
Prasa RAIL EASTERN CAPE REGION
East London Train Station
No 8 Station Road
East London
5200**

4.1 B-BBEE Joint Ventures or Consortiums

Bidders who would wish to respond to this RFP as a Joint Venture [JV] or consortium with B-BBEE entities, should state their intention to do so in their RFP submission. Such Bidders should also submit a signed JV or consortium agreement between the parties clearly stating the percentage [%] split of business and the associated responsibilities of each party. If such a JV or consortium agreement is unavailable, the partners should submit confirmation in writing of their intention to enter into a JV or consortium agreement should they be awarded business by PRASA through this RFP process. This written confirmation should clearly indicate the percentage [%] split of business

<p>BID DESCRIPTION: APPOINTMENT OF ONE SERVICE PROVIDER FOR SUPPLY AND DELIVERY OF TICKETING MATERIAL (PITIX ROLLS, ITIX ROLLS AND RIBBONS) ON AS AND WHEN BASIS FOR A PERIOD OF 36 MONTHS AT PRASA IN THE EASTERN CAPE REGION (ECR)</p>	
<p>BID NUMBER: ECR/RAIL/ICT/01/2026</p>	

and the responsibilities of each party. In such cases, award of business will only take place once a signed copy of a JV or consortium agreement is submitted to PRASA.

5 COMMUNICATION

- 5.1 For specific queries relating to this RFP during the RFP process, bidders are required to adhere strictly to the communication structure requirements. An RFP Clarification Form should be submitted to Simnikiwe.nqulo@prasa.com before or on the **23 June 2026**, substantially in the form set out in [Annexure B](#) hereto.
- 5.2 In the interest of fairness and transparency PRASA's response to such a query will be made available to the other Bidders who have attended a compulsory and a non-compulsory briefing session. For this purpose, PRASA will communicate with Bidders using the contact details provided at the compulsory briefing session.
- 5.3 After the closing date of the RFP, a Bidder may only communicate in writing with the Bid Secretariat, at telephone number 043 700 2386, email Siyasanga.Nyweba@prasa.com on any matter relating to its RFP Proposal.
- 5.4 Bidders are to note that changes to its submission will not be considered after the closing date.
- 5.5 Bidders are warned that a response will be liable for disqualification should any attempt be made by a Bidder either directly or indirectly to canvass any officer(s) or employee of PRASA in respect of this RFP between the closing date and the date of the award of the business. Furthermore, Bidders found to be in collusion with one another will automatically be disqualified and restricted from doing business with PRASA in future.
- 5.6 Bidders are advised to utilize this email address (Complaints@prasa.com) for lodging of complaints to PRASA in relation to this bid process. The following minimum information about the bidder must be included in the complaint:
- 6.6.1 Bid/Tender Description;
 - 6.6.2 Bid/Tender Reference Number;
 - 6.6.3 Closing date of Bid/Tender;
 - 6.6.4 Supplier Name;

BID DESCRIPTION: APPOINTMENT OF ONE SERVICE PROVIDER FOR SUPPLY AND DELIVERY OF TICKETING MATERIAL (PITIX ROLLS, ITIX ROLLS AND RIBBONS) ON AS AND WHEN BASIS FOR A PERIOD OF 36 MONTHS AT PRASA IN THE EASTERN CAPE REGION (ECR)	
BID NUMBER: ECR/RAIL/ICT/01/2026	

6.6.5 Supplier Contact details; and

6.6.6 The detailed compliant.

5.7 PRASA also encourages bidders to visit the PRASA website for whistleblowing contract details for alleged activities of suspected Fraud and or Corruption.

6 CONFIDENTIALITY

6.1 PRASA shall ensure all information related to this RFP is to be treated with strict confidence. In this regard Bidders / Bidders are required to certify that they have acquainted themselves with the Non-Disclosure Agreement. All information related to a subsequent contract, both during and after completion thereof, will be treated with strict confidence. Should the need however arise to divulge any information gleaned from provision of the Services, which is either directly or indirectly related to PRASA's business, written approval to divulge such information should be obtained from PRASA.

6.2 Bidders must clearly indicate whether any information submitted or requested from PRASA is confidential or should be treated confidentially by PRASA. In the absence of any such clear indication in writing, PRASA shall deem the response to the RFP to have waived any right to confidentiality and treat such information as public in nature.

6.3 By participating in the bidding process and submitting documentation you consent that we may process the same for the purposes of the bid. We may disclose your information [including your personal information, that of your directors, agents, service providers, joint venture partners, and service providers, collectively referred as "related parties"] to our service providers, including data storage and processing providers. We may obtain your information including that of your related parties from our service providers and Government agencies, Industry Regulators such as the Construction Industry Development Board, the Central Supplier Database. In case of our service providers, we will ensure that such third-party service providers will process your information and that of related parties for the purposes specified by us and such parties employ the appropriate security to protect that information.

6.4 We may disclose your information:

BID DESCRIPTION: APPOINTMENT OF ONE SERVICE PROVIDER FOR SUPPLY AND DELIVERY OF TICKETING MATERIAL (PITIX ROLLS, ITIX ROLLS AND RIBBONS) ON AS AND WHEN BASIS FOR A PERIOD OF 36 MONTHS AT PRASA IN THE EASTERN CAPE REGION (ECR)	 prasa <small>PASSENGER RAIL AGENCY OF SOUTH AFRICA</small>
BID NUMBER: ECR/RAIL/ICT/01/2026	

- as a result of our reporting obligations under the law, including to Parliament of the Republic of South Africa, to our external auditors, the Public Protector;
- where we are obliged by law [to the Government departments and entities such as Department of Trade and Industry/BEE Commission/ the CIDB, South African Revenue Services, Unemployment Insurance Fund, the industry Regulators, Industry Ombudsmen, etc.] or industry codes authorized by the various Regulator to do so;
- where we believe it is necessary to protect our rights
- on our website in connection with the supply chain management process
- to the payment processing service providers such as banks to assist with payment instructions;
- to law enforcement and Government Agencies for the purposes of fraud prevention;
- for security screening and checks to verify your personal information and that of related parties;
- to obtain tax clearance certificates;
- to our brokers/insurers;
- to service providers providing information and communication services.

6.5 Please refer to our Privacy Notice on our website.

7 INSTRUCTIONS FOR COMPLETING THE RFP

7.1 All responses to the RFP should be submitted in two sealed envelopes/boxes; the first envelop/box shall have the technical and compliance response, the second envelop/box shall only have the financial response and BBBEE response.

7.2 Bidders are required to package their response/Bid as follows:

Volume 1 (Envelope 1/Package 1)

- **Part A:** Mandatory Requirements Response
- **Part B:** Technical or Functional Response (response to scope of work)

Volume 2 (Envelope 2/ Package 2)

- **Part C:** Financial Proposal and Specific Goals

Volume 2 should be submitted in a separate sealed envelope. Bidders should make their pricing offer in envelope 2/package 2.

BID DESCRIPTION: APPOINTMENT OF ONE SERVICE PROVIDER FOR SUPPLY AND DELIVERY OF TICKETING MATERIAL (PITIX ROLLS, ITIX ROLLS AND RIBBONS) ON AS AND WHEN BASIS FOR A PERIOD OF 36 MONTHS AT PRASA IN THE EASTERN CAPE REGION (ECR)	 prasa <small>PASSENGER RAIL AGENCY OF SOUTH AFRICA</small>
BID NUMBER: ECR/RAIL/ICT/01/2026	

- 7.3 Bidders must submit 1 original response and may submit copies and an electronic version which must be contained in a Memory Card/External hard drive etc clearly marked in the Bidders name. PRASA reserves the right to consider information provided in all formats irrespective the format i.e original/copy/electronic.
- 7.4 Bidders should ensure that their response to the RFP is in accordance with the structure of this document.
- 7.5 Where Bidders are required to sign forms, they are required to do so using preferably black ink pen.
- 7.6 Any documents forming part of the original responses to RFP but which are not original in nature, should be certified as a true copy by a Commissioner of Oaths.
- 7.7 Each response to RFP must be in English and submitted in A4 format, except other graphic illustrations, which may not exceed A3 format, unless the contrary is specifically allowed for in this RFP. Responses to RFP should be neatly and functionally bound, preferably according to their different sections.
- 7.8 The original responses to RFP must be signed by a person duly authorized by each consortium member and Subcontractor to sign on their behalf, which authorization must form part of the responses to RFP as proof of authorization. By signing the responses to RFP the signatory warrants that all information supplied by it in its responses to RFP is true and correct and that the responses to RFP and each party whom the responses to RFP signatory represents, considers themselves subject to and bound by the terms and conditions of this RFP.
- 7.9 The responses to RFP formulation should be clear and concise and follow a clear methodology which responses to RFP should explain upfront in a concise Executive Summary and follow throughout the responses to RFP.
- 7.10 Responses to RFP must provide sufficient information and detail in order to enable PRASA to evaluate the responses to RFP, but should not provide unnecessary detail which does not add value and detracts from the ability of PRASA to effectively evaluate and understand the responses to RFP. The use of numbered headings, bullet points, sections, appendices and schedules are encouraged.

<p>BID DESCRIPTION: APPOINTMENT OF ONE SERVICE PROVIDER FOR SUPPLY AND DELIVERY OF TICKETING MATERIAL (PITIX ROLLS, ITIX ROLLS AND RIBBONS) ON AS AND WHEN BASIS FOR A PERIOD OF 36 MONTHS AT PRASA IN THE EASTERN CAPE REGION (ECR)</p>	 <p>prasa PASSENGER RAIL AGENCY OF SOUTH AFRICA</p>
<p>BID NUMBER: ECR/RAIL/ICT/01/2026</p>	

- 7.11 Information submitted as part of a responses to RFP should as far as possible, be orderly according to the order of the required information requested by PRASA. All pages should be consecutively numbered.
- 7.12 Responses to RFP should ensure that each requirement contained in the RFP is succinctly addressed. Responses to RFP should as far as possible use the terms and definitions applied in this RFP and should clearly indicate its interpretation of any differing terminology applied.
- 7.13 Response to RFP documents are to be submitted to the address specified in this RFP, and Bidders should ensure that the original and copies (where applicable) are identical in all respects as PRASA will not accept any liability for having disqualified a bidder for failing to provide a mandatory returnable document.
- 7.14 Unless otherwise expressly stated, all Proposals furnished pursuant to this RFP shall be deemed to be offers. Any exceptions to this statement must be clearly and specifically indicated.
- 7.15 Any additional conditions must be embodied in an accompanying letter. Subject only to clause 16 [Alterations made by the Bidder to Bid Prices] of the General Bid Conditions, alterations, additions or deletions must not be made by the Bidder to the actual RFP documents.
- 7.16 Bidders are required to review the Contract. Bidders may further amend and/ or delete any part of the Draft Contract where they deem fit to do so. Where Bidders have amended and or deleted any part of the Contract, it must be clearly visible by using track changes and must ensure that the disc copy of their bid submission for the Draft Contract is in word version and not password protected. **It must be noted that the marked-up Contract will form part of contract negotiations processes with the preferred bidder.**

BID DESCRIPTION: APPOINTMENT OF ONE SERVICE PROVIDER FOR SUPPLY AND DELIVERY OF TICKETING MATERIAL (PITIX ROLLS, ITIX ROLLS AND RIBBONS) ON AS AND WHEN BASIS FOR A PERIOD OF 36 MONTHS AT PRASA IN THE EASTERN CAPE REGION (ECR)	 prasa <small>PASSENGER RAIL AGENCY OF SOUTH AFRICA</small>
BID NUMBER: ECR/RAIL/ICT/01/2026	

8 RFP TIMETABLE

PRASA may at its sole discretion amend any of the milestone dates indicated in the table below. Bidders will be informed of any amendments to the timeline through the issue of the Addendum/ Briefing Notes.

RFP PROCESS	MILESTONE DATES
Bid issue date	12 JUNE 2026
Briefing Session for Bidders at	N/A
Closing date for Questions	23 June 2026
Closing date for Responses	26 June 2026
Closing Date for Submission of final Bid	13 July 2026
Evaluation of Proposals (Bidders note that PRASA may call for Presentation of bidders offers at any stage of the evaluation process)	TBC
Appointment of the successful Bidder	TBC
Contract Negotiations	TBC
Signing of Contract	TBC
Contract Commencement	TBC

PRASA may at its sole discretion amend any of the milestone dates indicated in the table above. Bidders will be informed of any amendments to the timeline through the issue of briefing notes.

9 LEGAL COMPLIANCE

- 9.1 Bidders should ensure that they comply with all the requirements of the RFP and if Bidders fail to submit any of the required documents, such Bids may, at the sole discretion of PRASA, be disqualified. PRASA reserves the right to call a Bidder to provide additional documents which may have not been submitted.
- 9.2 The successful Bidder [hereinafter referred to as the **Service Provider**] shall be in full and complete compliance with any and all applicable laws and regulations.

BID DESCRIPTION: APPOINTMENT OF ONE SERVICE PROVIDER FOR SUPPLY AND DELIVERY OF TICKETING MATERIAL (PITIX ROLLS, ITIX ROLLS AND RIBBONS) ON AS AND WHEN BASIS FOR A PERIOD OF 36 MONTHS AT PRASA IN THE EASTERN CAPE REGION (ECR)	 prasa <small>PASSENGER RAIL AGENCY OF SOUTH AFRICA</small>
BID NUMBER: ECR/RAIL/ICT/01/2026	

10 NATIONAL TREASURY’S CENTRAL SUPPLIER DATABASE

Bidders are required to self-register on National Treasury’s Central Supplier Database (CSD) which has been established to centrally administer supplier information for all organs of state and facilitate the verification of certain key supplier information. Only foreign suppliers with no local registered entity need not register on the CSD. The CSD can be accessed at <https://secure.csd.gov.za>. Bidders are required to provide the following to PRASA in order to enable it to verify information on the CSD:

Supplier Number: _____ **Unique registration reference number:** _____.

11 TAX COMPLIANCE

- 11.1 Bidders must be compliant when submitting a proposal to PRASA and remain compliant for the entire contract term with all applicable tax legislation, including but not limited to the Income Tax Act, 1962 (Act No. 58 of 1962) as amended and Value Added Tax Act, 1991 (Act No. 89 of 1991) as amended.
- 11.2 It is a condition of this RFP that the tax matters of the successful bidder be in order, or that satisfactory arrangements have been made with South African Revenue Service (SARS) to meet the bidder’s tax obligations.
- 11.3 The Tax Compliance status requirements are also applicable to foreign Bidders/ individuals who wish to submit bids.
- 11.4 Bidders are required to be registered on the Central Supplier Database (CSD) as indicated in paragraph 12 and the National Treasury shall verify the Bidder’s tax compliance status through the Central Supplier Database (CSD).
- 11.5 Where Consortia / Joint Ventures / Sub-contractors are involved, each party must be registered on the Central Supplier Database (CSD) and their tax compliance status will be verified through the Central Supplier Database (CSD).

For this purpose, the attached **SBD 1 marked Annexure..... must be completed and submitted as an essential returnable document by the closing date and time of the bid.**

New Tax Compliance Status (TCS) System

BID DESCRIPTION: APPOINTMENT OF ONE SERVICE PROVIDER FOR SUPPLY AND DELIVERY OF TICKETING MATERIAL (PITIX ROLLS, ITIX ROLLS AND RIBBONS) ON AS AND WHEN BASIS FOR A PERIOD OF 36 MONTHS AT PRASA IN THE EASTERN CAPE REGION (ECR)	 prasa <small>PASSENGER RAIL AGENCY OF SOUTH AFRICA</small>
BID NUMBER: ECR/RAIL/ICT/01/2026	

11.6 SARS has implemented a new Tax Compliance Status (TCS) system in terms of which a taxpayer is now able to authorise any 3rd party to verify its compliance status in one of two ways: either through the use of an electronic access PIN, or through the use of a Tax Clearance Certificate obtained from the new TCS system.

11.7 Bidders are required to provide the following to PRASA in order to enable it to verify their tax compliance status:

Tax Compliance Status (TCS) Pin:_____.

12 PROTECTION OF PERSONAL DATA

In responding to this bid, PRASA acknowledges that it may obtain and have access to personal data of the Bidders or any of its/his/her/their officers, employees, agents or advisers. PRASA agrees that it shall only process the information disclosed by Bidders in their response to this bid for the purpose of evaluating and subsequent award of business and in accordance with any applicable law. Furthermore, PRASA will not otherwise modify, amend or alter any personal data submitted by Bidders or disclose or permit the disclosure of any personal data to any Third Party without the prior written consent from the Bidders. Similarly, PRASA requires Bidders to process any personal information disclosed by PRASA in the bidding process in the same manner.

BID DESCRIPTION: APPOINTMENT OF ONE SERVICE PROVIDER FOR SUPPLY AND DELIVERY OF TICKETING MATERIAL (PITIX ROLLS, ITIX ROLLS AND RIBBONS) ON AS AND WHEN BASIS FOR A PERIOD OF 36 MONTHS AT PRASA IN THE EASTERN CAPE REGION (ECR)	 prasa <small>PASSENGER RAIL AGENCY OF SOUTH AFRICA</small>
BID NUMBER: ECR/RAIL/ICT/01/2026	

SECTION 2

BACKGROUND OVERVIEW AND SCOPE REQUIREMENTS

1 INTRODUCTION AND BACKGROUND

Passenger Rail Agency of South Africa (“PRASA”) has identified the need to appoint a service provider for **APPOINTMENT OF ONE SERVICE PROVIDER FOR SUPPLY AND DELIVERY OF TICKETING MATERIAL (PITIX ROLLS, ITIX ROLLS AND RIBBONS) ON AS AND WHEN BASIS FOR A PERIOD OF 36 MONTHS AT PRASA IN THE EASTERN CAPE REGION (ECR)**

Establishing a contract will mitigate the risk of Supply Chain Management going out on RFQ’s to request bidders to submit quotes. This delays the process as ICT need to ensure that Customer Services always have ticket material available. With the contract the ticketing material can be ordered on short notice without any delays to the business.

Prasa Rail Eastern Cape is currently utilizing ticketing devices Pitix devices which require thermal rolls to print tickets and ITIX machines which require a ticket roll and ribbon to print tickets. This is crucial material to ensure that revenue is generated and that the commuter is issued with a valid ticket(s).

2 OVERVIEW

PRASA seeks to benefit from this partnership in the following ways:

- 2.1.1 PRASA must receive reduced cost of acquisition and improved service benefits resulting from the Service Provider’s economies of scale and streamlined service processes.
- 2.1.2 PRASA must achieve appropriate availability that meets user needs while reducing costs for both PRASA and the chosen Service Provider(s).

BID DESCRIPTION: APPOINTMENT OF ONE SERVICE PROVIDER FOR SUPPLY AND DELIVERY OF TICKETING MATERIAL (PITIX ROLLS, ITIX ROLLS AND RIBBONS) ON AS AND WHEN BASIS FOR A PERIOD OF 36 MONTHS AT PRASA IN THE EASTERN CAPE REGION (ECR)	
BID NUMBER: ECR/RAIL/ICT/01/2026	

2.1.3 PRASA must receive proactive improvements from the Service Provider with respect to provision of Services and related processes.

2.1.4 PRASA's overall competitive advantage must be strengthened by the chosen Service Provider's leading-edge technology and service delivery systems.

2.1.5 PRASA end users must be able to rely on the chosen Service Provider's personnel for service enquiries, recommendations and substitutions.

2.1.6 PRASA must reduce costs by streamlining its acquisition of Services, including managed service processes on a Group basis.

2.2 STATUS QUO

2.2.1. There is currently no contract in place for these goods and services.

PROBLEM STATEMENT

2.3.1 The ticketing devices require thermal rolls for the Pitix devices and the printer material and ribbons for the ticketing devices. Without the relevant ticketing material, the region would not be able to issue tickets to commuters and collect revenue.

Objectives of the Provision of the Service

2.3.2.1 PRASA intends through the provision of this service to achieve the highest quality standard of cleanliness of this facility.

2.3.2.2 PRASA has a legal and statutory obligation to maintain its operating environment in a safe, environmentally sound and responsible manner.

BID DESCRIPTION: APPOINTMENT OF ONE SERVICE PROVIDER FOR SUPPLY AND DELIVERY OF TICKETING MATERIAL (PITIX ROLLS, ITIX ROLLS AND RIBBONS) ON AS AND WHEN BASIS FOR A PERIOD OF 36 MONTHS AT PRASA IN THE EASTERN CAPE REGION (ECR)	
BID NUMBER: ECR/RAIL/ICT/01/2026	

2.3 OBJECTIVE OF THE PROPOSED STATEMENT

Desired outcomes for carrying out the proposed project

- The procurement of the ticketing material for the Pitix/ITIX machines would ensure business continuity and for business in the East London and Gqeberha corridors to collect revenue onboard trains and stations. Traditional Approach will be used as a procurement strategy for this project. It will follow an open tender process as prescribed by National Treasury..

2.4 PROJECT BENEFITS TO PRASA

Prasa Rail would be able to collect revenue as per the requirements of the business

3 KEY OBJECTIVES OF THE RFP

This RFP has been prepared for the following purposes:

- 3.1 To set out the rules of participation in the Bid process referred to in this RFP.
- 3.2 To disseminate information on the Project contemplated in this RFP.
- 3.3 To give guidance to Bidders on the preparation of their RFP Bids.
- 3.4 To gather information from Bidders that is verifiable and can be evaluated for the purposes of appointing a successful Bidder.
- 3.5 To enable PRASA to select a successful Bidder that is:
 - a) technically qualified and meet the empowerment criteria described in this RFP;
 - b) Carry all the obligations of the Contract.

BID DESCRIPTION: APPOINTMENT OF ONE SERVICE PROVIDER FOR SUPPLY AND DELIVERY OF TICKETING MATERIAL (PITIX ROLLS, ITIX ROLLS AND RIBBONS) ON AS AND WHEN BASIS FOR A PERIOD OF 36 MONTHS AT PRASA IN THE EASTERN CAPE REGION (ECR)	 prasa <small>PASSENGER RAIL AGENCY OF SOUTH AFRICA</small>
BID NUMBER: ECR/RAIL/ICT/01/2026	

4 SCOPE OF WORK

The specification of work for this project shall entail the following activities:

ITix TICKET MATERIAL

PHYSICAL DIMENSIONS OF TICKET MATERIAL ON ROLLS FOR USE ON THE PRINTRONIX SL/T4M PRINTERS

The paper ticket material will be supplied in continuous rolls, without joints, splices or breaks, and wound onto a central circular core.

1. Core Dimensions

1.1 The inner core of the roll will have the following dimension:

- Inner diameter : 76 mm
- Core thickness : 5 mm
- External diameter : 86 mm
- Width : 86.5 mm

1.2 The core of the roll will preferably be made of a cardboard material suitable for the purpose and will not be deformed or collapse under normal conditions of transport or storage.

1.3 The material must not be attached with sticky tape to the inner core.

2. ITix Roll Dimensions

2.1 The material will be wound evenly on the core and with sufficient tension, so as to prevent telescoping with normal handling.

2.2 The ticket material will be wound on to the inner core in the following direction:

- With the roll resting on a horizontal surface, and viewed from the top, the material will be wound in a clockwise direction with the conditions of transport facing to the inside (reverse side) and the printing surface facing outward.

BID DESCRIPTION: APPOINTMENT OF ONE SERVICE PROVIDER FOR SUPPLY AND DELIVERY OF TICKETING MATERIAL (PITIX ROLLS, ITIX ROLLS AND RIBBONS) ON AS AND WHEN BASIS FOR A PERIOD OF 36 MONTHS AT PRASA IN THE EASTERN CAPE REGION (ECR)	
BID NUMBER: ECR/RAIL/ICT/01/2026	

- 2.3 A black line of 3 mm must be printed across the width of the ticket material every 54mm.
- 2.4 The thickness of the ticket material will be 0,250 mm ± 0,025 mm. The thickness should be measured as per BS 3983 part 2 of 1982 (ISO 534 1980).
- 2.5 The mass of the material will be 220-g/m² ± 10 g/m².
- 2.6 Roll Dimensions
 - 2.6.1 The external diameter of a fully wound roll will be 203 mm ± 1 mm.
 - 2.6.2 The width of the ticket material roll must be 86.5mm.
 - 2.6.3 The length of the material on a roll will be 100 meters.

Note: The width of the ticket will be 54 mm ± 0,4 mm The length of ticket will be 86,5 mm ± 0,7 mm.

GENERAL DESCRIPTION of ITix TICKET MATERIAL

Construction

- The ticket material may be either of a single or multiple layer construction. Where multiple layers are used, the layers will not separate under normal use.
- The face and reverse side of the ticket will be suitable for accepting printed information.
- Both sides of the ticket may be required to carry pre-printed information and/or background printing.
- The material will be supplied in continuous rolls, without joints, splices or breaks and wound onto a central circular core.
- The final acceptability of the material will be determined by the performance of the tickets in service.

BID DESCRIPTION: APPOINTMENT OF ONE SERVICE PROVIDER FOR SUPPLY AND DELIVERY OF TICKETING MATERIAL (PITIX ROLLS, ITIX ROLLS AND RIBBONS) ON AS AND WHEN BASIS FOR A PERIOD OF 36 MONTHS AT PRASA IN THE EASTERN CAPE REGION (ECR)	
BID NUMBER: ECR/RAIL/ICT/01/2026	

Quality of Material

- The base material will be free of holes, electrically, magnetically and thermally conductive particles, loose dust, loose powder, fuzz, residue chemicals and slime spots likely to damage or impede the operation of the printing machines or readers.
- The base material will be free of joints, cracks, high spots, burrs, splinters, sharp edges and dents.
- The base material will be free of any translucent areas or spots that could affect the operation of optical sensors.
- The base material will be free of any wrinkles or creases.
- The ticket materials will not cause injury either by contact, inhalation or ingestion.
- The base material will be free of any other defect not listed above, which might detract from the magnetic printing, general performance or appearance of the final product.
- The characteristics of the material should be such that dirt accumulation and wear of the machines should be restricted to a minimum; hence the material must be capable of being cleanly cut without forming dust or burring.
- The material should be treated to prevent the generation of static sufficient to impair its serviceability.
- The ticket material will be unaffected by magnetic fields, and will retain no detectable residual magnetism.
- The quality of the material will be such so as to ensure uninterrupted operation of the ticket issuing device, and allow good quality print, using both thermal and impact type printers, but predominantly for thermal printing.
- The printing on the ticket material must last for at least 5 weeks and should not fade.

Quality Control

- Quality of ticket material is very important. The successful tenderer will be responsible for the quality of ticket material at all times.

BID DESCRIPTION: APPOINTMENT OF ONE SERVICE PROVIDER FOR SUPPLY AND DELIVERY OF TICKETING MATERIAL (PITIX ROLLS, ITIX ROLLS AND RIBBONS) ON AS AND WHEN BASIS FOR A PERIOD OF 36 MONTHS AT PRASA IN THE EASTERN CAPE REGION (ECR)	
BID NUMBER: ECR/RAIL/ICT/01/2026	

Printing Surface

- The entire face of the ticket is defined as the "printing surface" and will conform to the following requirements:

Resolution

- The quality of the printing surface will provide adequate resolution of printed characters and graphics when using a thermal printing head with a line density of six dots per millimetre.

Absorbability

- The printing surface will be sufficiently absorbent to ensure proper keying of the thermal transfer ink while remaining dimensionally stable within the specified humidity range.
- The printed characters will not smear when wiped over by a felt pad one second after being printed by the machine, under service conditions.

Durability

- It must not be possible to erase printed characters without damaging the surface of the ticket.

Security Background

- A security background needs to be printed on the printing surface of ticket material. The purpose of the security background is to impede forging of tickets and to assist with the identification of forged material and tickets.

Quality of Security Background

- Security background printing will not affect printing qualities of the ticket material. It will not affect the smoothness of the print face, nor affect the ability of material to accept printing. Simultaneously, security background printing may not affect the ticket issuing machine in any way.

Number of Security Background Colours

- It is a requirement that security background colours be changed on a regular basis. Tenderers are to provide the option to provide security background in 6 different colours.

Colours Used for Security Background

BID DESCRIPTION: APPOINTMENT OF ONE SERVICE PROVIDER FOR SUPPLY AND DELIVERY OF TICKETING MATERIAL (PITIX ROLLS, ITIX ROLLS AND RIBBONS) ON AS AND WHEN BASIS FOR A PERIOD OF 36 MONTHS AT PRASA IN THE EASTERN CAPE REGION (ECR)	
BID NUMBER: ECR/RAIL/ICT/01/2026	

Tenderers are required to suggest colours to be utilised in printing the security background. It must be difficult to make acceptable photocopies or electronic scanning of security background printing. Amongst others, tenderers should investigate using neon or metallic inks. Only one colour will be used at a time.

Description of Security Background Printing for Prasa Rail

Viewing a ticket from the printing face side of a ticket in the portrait orientation, background security printing will be printed at an angle of 45°, from the lower left-hand to upper right-hand side

Security background printing will consist of the word "PRASA RAIL" printed in the official Prasa Rail font. The word will be repeated and spaced such that orientation of words between lines does not coincide. Full details will be furnished to the successful tenderer.

Printing the Prasa Rail Conditions of Sale on Reverse Side of Ticket

A statement referring to the general conditions of sale will be printed on the reverse side of a ticket.

Orientation of Printing

- For the purpose of describing printing on the reverse side of ticket material, a ticket will be viewed in the landscape orientation.

Printing of Messages

- Provision must be made to print short messages on the reverse side of tickets of which the following is an example:

Conditions of Sale

The conditions of sale must be printed on the reverse side of the ticket. The following text is required:

"Issued by the Passenger Rail Agency of South Africa subject to the conditions contained in its Metro Services Book which are obtainable on request".

The notice will be printed such that:

- A minimum clearance of 2 mm is maintained between the notice and the edge of the ticket.

BID DESCRIPTION: APPOINTMENT OF ONE SERVICE PROVIDER FOR SUPPLY AND DELIVERY OF TICKETING MATERIAL (PITIX ROLLS, ITIX ROLLS AND RIBBONS) ON AS AND WHEN BASIS FOR A PERIOD OF 36 MONTHS AT PRASA IN THE EASTERN CAPE REGION (ECR)	 prasa <small>PASSENGER RAIL AGENCY OF SOUTH AFRICA</small>
BID NUMBER: ECR/RAIL/ICT/01/2026	

- Regardless of the registration of the edge of the ticket with regards to the beginning of a notice, at least one complete notice will be displayed on any ticket.

Changes to Text

- It is probable that Prasa Rail will require changes to the "conditions of sale" text from time to time. The changes will be negotiated with the successful tenderer. It is expected that when requests are reasonable, financial implications to Prasa Rail will be negligible.

Advertising Space

- The reverse side of a ticket will be used for advertising. An advert of 35mm X 25mm will be printed on the reverse side of the ticket which will be discussed with the successful tenderer who must be able to print colour adverts.

Regional Name and Numbering of Prasa Rail Ticket Material

- Viewing a ticket from the printing face side of a ticket in the portrait orientation with the outer end pointing upwards, the regional name and roll numbering shall be printed at an angle of 90 °, on the right hand side of the ticket.
- The printing of the regional name and roll numbers shall consist of alpha and numeric digits at a font size of 7 or 8 (letter size). Regardless of the registration of cutting position with regards to the beginning of a regional name and roll number, at least one complete regional name and roll number shall be displayed on any ticket. Full details will be furnished to the successful tenderer.

Example of Ticket Numbering

BID DESCRIPTION: APPOINTMENT OF ONE SERVICE PROVIDER FOR SUPPLY AND DELIVERY OF TICKETING MATERIAL (PITIX ROLLS, ITIX ROLLS AND RIBBONS) ON AS AND WHEN BASIS FOR A PERIOD OF 36 MONTHS AT PRASA IN THE EASTERN CAPE REGION (ECR)



BID NUMBER: ECR/RAIL/ICT/01/2026

Breakdown of name and number to be used on ticket material with unique numbering for each roll.

EC

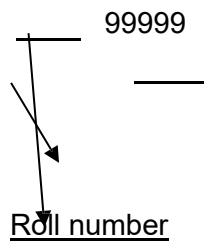

Regional name

EC 99999

EC 99999

BID DESCRIPTION: APPOINTMENT OF ONE SERVICE PROVIDER FOR SUPPLY AND DELIVERY OF TICKETING MATERIAL (PITIX ROLLS, ITIX ROLLS AND RIBBONS) ON AS AND WHEN BASIS FOR A PERIOD OF 36 MONTHS AT PRASA IN THE EASTERN CAPE REGION (ECR)	 prasa <small>PASSENGER RAIL AGENCY OF SOUTH AFRICA</small>
BID NUMBER: ECR/RAIL/ICT/01/2026	

Additional Security Features on Ticket Material

Tenders are requested to comment and quote separately on the following additional features per ITix rolls:

- Fixed offset metallic inks;
- Coin reactive inks;
- Fixed Offset Fluorescent inks; and
- Copy protection via Oyster Covert ink.

Tenderers are invited to recommend any alternative security features with the relevant cost per roll.

POS THERMAL PAPER ROLL

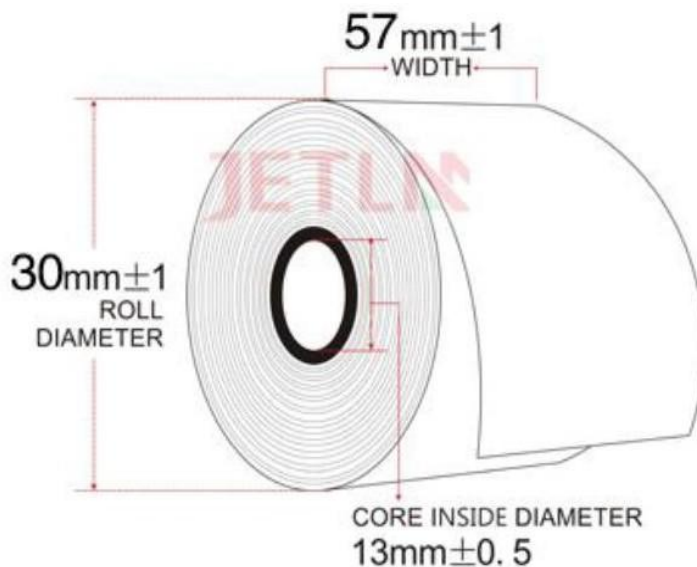

BID DESCRIPTION: APPOINTMENT OF ONE SERVICE PROVIDER FOR SUPPLY AND DELIVERY OF TICKETING MATERIAL (PITIX ROLLS, ITIX ROLLS AND RIBBONS) ON AS AND WHEN BASIS FOR A PERIOD OF 36 MONTHS AT PRASA IN THE EASTERN CAPE REGION (ECR)	 prasa <small>PASSENGER RAIL AGENCY OF SOUTH AFRICA</small>
BID NUMBER: ECR/RAIL/ICT/01/2026	

The material shall be supplied in continuous rolls, without joints, splices or breaks, and wound onto a central circular core.

- ❖ Inner Diameter : ± 0.5 mm
- ❖ External Diameter : ± 0.5 mm
- ❖ Width : 57 mm + 0.1 mm; -0

- The core of the Roll shall preferably be made of a synthetic material suitable for the purpose and shall not be deformed or collapse under the normal conditions of transport or storage.
- The material shall be wound evenly on the core and with sufficient tension, as to prevent telescoping with normal handling.
- The ticket material shall be wound to the inner core in the following direction:

The roll resting on a horizontal surface and viewed from the top. The tape shall be wound in a clockwise direction with the printing face facing outward or thermal coating on the outside of the roll. The security printing shall be orientated such that us read from the outer end of the material, when the outer end of the roll is held upwards.

- The external diameter of a fully wound PITix roll shall be 30 mm \pm 1 mm. Tenders are to state the length of material contained on a roll.
- The width of the ticket shall be 57 mm \pm 1 mm. the width to be measured by an optical method.
- The colour is to be white unless otherwise specified.

Tenderers shall submit sufficient samples of the material offered to produce a minimum of 200 test tickets for evaluation purposes; this shall be provided free of charge. This is to test to verify if the material is compatible to our printers.

BID DESCRIPTION: APPOINTMENT OF ONE SERVICE PROVIDER FOR SUPPLY AND DELIVERY OF TICKETING MATERIAL (PITIX ROLLS, ITIX ROLLS AND RIBBONS) ON AS AND WHEN BASIS FOR A PERIOD OF 36 MONTHS AT PRASA IN THE EASTERN CAPE REGION (ECR)	 prasa <small>PASSENGER RAIL AGENCY OF SOUTH AFRICA</small>
BID NUMBER: ECR/RAIL/ICT/01/2026	

Conditions of Sale

The conditions of sale must be printed on the reverse side of the ticket. The following text is required:

"This ticket is issued by the Passenger Rail Agency of South Africa subject to the Conditions of Carriage and is not transferable.

Please report any fraudulent activity to the PRASA Fraud Hotline at toll free number 0800212679 or landline +27 43 700 2626."

The notice will be printed such that a minimum clearance of 2 mm is maintained between the notice and the edge of the ticket.

Thermal Material for PITix Rolls

The ticket material supplied by Tenderer for use in the Portable Ticketing Device (PITix) on EC Prasa Rail Region must comply (firm requirement) to the following specifications:

- Material : durable Thermal paper roll
- Thickness : 100mic Standard as per Tappi T- 4111
- Thermal Coating : shall meet or exceed ANSI 3.11 specification.
- Smoothness : Max. 75 Sheffield units
- Top Coating : the thermo- sensitive surface of the ticket stock

must be top coated.

- Pre- print : tickets can be pre- printed on one or both sides.
- Ink for Thermo- sensitive side: Laser printer approved ink without

Whiteners.

- Ink for Rear side : off ink

BID DESCRIPTION: APPOINTMENT OF ONE SERVICE PROVIDER FOR SUPPLY AND DELIVERY OF TICKETING MATERIAL (PITIX ROLLS, ITIX ROLLS AND RIBBONS) ON AS AND WHEN BASIS FOR A PERIOD OF 36 MONTHS AT PRASA IN THE EASTERN CAPE REGION (ECR)	 prasa <small>PASSENGER RAIL AGENCY OF SOUTH AFRICA</small>
BID NUMBER: ECR/RAIL/ICT/01/2026	

- ❖ Tenderers to state the meterage on each roll.

Ticket Roll Numbers :

Viewing a ticket from the printing face side of a ticket in the portrait orientation with the outer end pointing upwards, the regional name and roll numbering shall be printed at an angle of 90 °, on the right-hand side of the ticket.

Security Features: BLUE, Fluorescent Ink with Prasa Rail Logo

Viewing a ticket from the printing face side of a ticket in the portrait orientation, background security printing will be printed at an angle of 45°, from the lower left-hand to upper right-hand side

Security background printing will consist of the word “PRASA RAIL” printed in the official PRASA font. The word will be repeated and spaced such that orientation of words between lines does not coincide.

The ticket material should have at the end of the Roll a Redline printed when there is only 60mm of the paper is still left in the device to warn the operator to change his/her roll.

PACKING, LABELLING AND SHIPPING OF MATERIAL

- The successful tenderer will be entirely responsible to PRASA Rail for all the material until it is accepted by Prasa Rail, and an acceptance certificate is issued.

Material in Rolls

- The ITix rolls will be packed upright, with rolls laid flat and each roll individually shrink wrapped in moisture proof wrapping in quantities of three, in suitable corrugated cardboard containers.
- The smaller rolls for the PTix’s will be packed in corrugated cardboard containers in quantities prescribed in the annexure hereto. The individual rolls will be shrink- wrapped in moisture proof wrapping.

All ticket material will be packed so as to prevent damage in transit or storage.

BID DESCRIPTION: APPOINTMENT OF ONE SERVICE PROVIDER FOR SUPPLY AND DELIVERY OF TICKETING MATERIAL (PITIX ROLLS, ITIX ROLLS AND RIBBONS) ON AS AND WHEN BASIS FOR A PERIOD OF 36 MONTHS AT PRASA IN THE EASTERN CAPE REGION (ECR)	 prasa <small>PASSENGER RAIL AGENCY OF SOUTH AFRICA</small>
BID NUMBER: ECR/RAIL/ICT/01/2026	

Each cardboard carton will be permanently marked on at least two opposite sides with the following information:

- Contents
- Material type and colour
- Batch number
- Order number

For ITix” or “For PTix”

BID DESCRIPTION: APPOINTMENT OF ONE SERVICE PROVIDER FOR SUPPLY AND DELIVERY OF TICKETING MATERIAL (PITIX ROLLS, ITIX ROLLS AND RIBBONS) ON AS AND WHEN BASIS FOR A PERIOD OF 36 MONTHS AT PRASA IN THE EASTERN CAPE REGION (ECR)	 prasa <small>PASSENGER RAIL AGENCY OF SOUTH AFRICA</small>
BID NUMBER: ECR/RAIL/ICT/01/2026	

6. EVALUATION METHODOLOGY

The evaluation of Bids will be based on the information contained in Bids received in RFP and, which may be further supplemented by presentations and clarification information provided, if required. All Bids shall be equally evaluated by various committees involved in the evaluation process in accordance with stated Evaluation Criteria. Procurement integrity and fairness, transparency, competitiveness and full accountability will at all times be paramount.

6.1 EVALUATION AND SCORING METHODOLOGY

The evaluation of the Bids by the evaluation committees will be conducted at various levels. The following levels will be applied in the evaluation:

LEVEL	DESCRIPTION
Verify completeness	The Bid is checked for completeness and whether all required documentation, certificates; verify completeness warranties and other Bid requirements and formalities have been complied with. Incomplete Bids will be disqualified.
Verify compliance	The Bids are checked to verify that the essential RFP requirements have been met. Non-compliant Bids will be disqualified.
Detailed Evaluation of Technical	Detailed analysis of Bids to determine whether the Bidder is capable of delivering the Project in terms of business and technical requirements. The minimum threshold for technical evaluation is [], any bidder who fails to meet the minimum requirement will be disqualified and not proceed with the evaluation of Price and Specific Goals.
Specific Goals	Evaluate Specific Goals
Price Evaluation	Bidders will be evaluated on price offered.
Scoring	Scoring of Bids using the Evaluation Criteria.
Recommendation	Report formulation and recommendation of Preferred and Reserved Bidders

BID DESCRIPTION: APPOINTMENT OF ONE SERVICE PROVIDER FOR SUPPLY AND DELIVERY OF TICKETING MATERIAL (PITIX ROLLS, ITIX ROLLS AND RIBBONS) ON AS AND WHEN BASIS FOR A PERIOD OF 36 MONTHS AT PRASA IN THE EASTERN CAPE REGION (ECR)	 prasa <small>PASSENGER RAIL AGENCY OF SOUTH AFRICA</small>
BID NUMBER: ECR/RAIL/ICT/01/2026	

LEVEL	DESCRIPTION
Best and Final Offer	PRASA may go into the Best and Final Offer process in the instance where no bid meets the requirements of the RFP and/or the Bids are too close in terms of points awarded.
Approval	Approval and notification of the final Bidder.

6.2 EVALUATION CRITERIA

Qualifying bidders for this project shall be evaluated in terms of their business credentials, financial standing, empowerment, technical capacity and experience. The evaluation committee shall use the following Evaluation Criteria depicted in Table 1 for the selection of the preferred bidder.

EVALUATION CRITERIA	WEIGHTING
Stage 1 – Compliance Requirements	
Stage 1A	Mandatory Compliance Requirements
Stage 1B	Other-Mandatory Compliance Requirements
Stage 1C	Documents required for scoring
Stage 2	
Price	80
Specific Goals	20

Details of the stages outlined in table 1 above are presented in the following sections.

BID DESCRIPTION: APPOINTMENT OF ONE SERVICE PROVIDER FOR SUPPLY AND DELIVERY OF TICKETING MATERIAL (PITIX ROLLS, ITIX ROLLS AND RIBBONS) ON AS AND WHEN BASIS FOR A PERIOD OF 36 MONTHS AT PRASA IN THE EASTERN CAPE REGION (ECR)	 prasa <small>PASSENGER RAIL AGENCY OF SOUTH AFRICA</small>
BID NUMBER: ECR/RAIL/ICT/01/2026	

7. STAGE 1: COMPLIANCE REQUIREMENTS

Bidders are to comply with the following requirements and failure to comply may lead to disqualification.

Stage 1A – Mandatory Requirements - (To be submitted in envelope 1)

If you do not submit/meet the following mandatory documents/requirements, your bid will be automatically disqualified.

Only bidders who comply with stage 1A will be evaluated further.

No.	Description of requirement	
a)	Price Schedule/Bill of Quantities (BOQ) and Bid Form C must be submitted as Volume 2 in Envelope 2 To facilitate like-for like comparison. Bidders must submit pricing strictly in accordance with this price schedule and not utilize a different format. Deviation from this pricing schedule will result in a bid being declared non-responsive.	
b)	Bidders to fill and sign the Submission register at SCM reception on submission of tender documents	

BID DESCRIPTION: APPOINTMENT OF ONE SERVICE PROVIDER FOR SUPPLY AND DELIVERY OF TICKETING MATERIAL (PITIX ROLLS, ITIX ROLLS AND RIBBONS) ON AS AND WHEN BASIS FOR A PERIOD OF 36 MONTHS AT PRASA IN THE EASTERN CAPE REGION (ECR)	 prasa <small>PASSENGER RAIL AGENCY OF SOUTH AFRICA</small>
BID NUMBER: ECR/RAIL/ICT/01/2026	

Stage 1B – Other Mandatory Requirements - (To be submitted in envelope 1)

If you do not submit the following mandatory documents/requirements, PRASA may request the bidder to submit the information within seven (7) working days. Should this information not be provided, your bid proposal will be recalled.

No.	Description of requirement	
a)	Proof of Company Registration Documents, (Certificate of Incorporation or CK1 or CK2)	
b)	Copies of Directors` ID documents;	
c)	Valid Tax Pin letter (must be valid on closing date of submission of the proposal) issued by SARS.	
d)	Completion and submission of ALL RFP documentation (includes ALL declarations)	
e)	CSD Summary report / CSD reference number	
f)	Proof of Bank Account (i.e letter issued by the bank)	
g)	Valid Original, or certified copy of Letter of Good Standing (COID)	
h)	Joint Venture / Consortium agreement / Trust Deed/ Confirmation in writing of intention to enter into a JV or consortium agreement should they be awarded business by PRASA through this RFP process (if applicable)	

Stage 1C – Documents required for Scoring

Documents required for Scoring - The following Non-Mandatory Documents used for purposes of scoring a bid. If not submitted by the closing date and time of this bid will not result in a Respondent's disqualification. However, Bidders will receive a score of zero for the applicable evaluation criterion: -

Certified copy of ID Documents of the Owners
Audited Annual Financial/ B- BBEE Certificate / Affidavit
CIPC Documents / B-BBEE Certificate / Affidavit
Certified copy of ID Documents of the Owners and Doctor's note confirming the disability

BID DESCRIPTION: APPOINTMENT OF ONE SERVICE PROVIDER FOR SUPPLY AND DELIVERY OF TICKETING MATERIAL (PITIX ROLLS, ITIX ROLLS AND RIBBONS) ON AS AND WHEN BASIS FOR A PERIOD OF 36 MONTHS AT PRASA IN THE EASTERN CAPE REGION (ECR)	 prasa <small>PASSENGER RAIL AGENCY OF SOUTH AFRICA</small>
BID NUMBER: ECR/RAIL/ICT/01/2026	

Stage 2

Bidders should provide their price proposal in envelope 2, which should include Form C (Financial Offer) and also provide proof of Specific Goals.

The following formula, shall be used by the Bid Evaluation Committee to allocate scores to the interested bidders:

The maximum points for this tender are allocated as follows:

	POINTS
PRICE	80
SPECIFIC GOALS	20
TOTAL POINTS FOR PRICE AND SPECIFIC GOALS	100

**FORMULAE FOR PROCUREMENT OF GOODS AND SERVICES
POINTS AWARDED FOR PRICE
THE 80/20 PREFERENCE POINT SYSTEMS**

A maximum of points is allocated for price on the following basis:

80/20

$$PS = 80 \left(1 - \frac{Pt - Pmin}{Pmin} \right)$$

Where

Ps = Points scored for price of tender under consideration

Pt = Price of tender under consideration

Pmin = Price of lowest acceptable tender

POINTS AWARDED FOR SPECIFIC GOALS

In terms of Regulation 4(2); 5(2); 6(2) and 7(2) of the Preferential Procurement Regulations, preference points must be awarded for specific goals stated in the tender. For the purposes of this tender the tenderer will be allocated points based on the goals stated in table 1 below as may be supported by proof/ documentation stated in the conditions of this tender:

In cases where organs of state intend to use Regulation 3(2) of the Regulations, which states that, if it is unclear whether the 80/20 or 90/10 preference point system applies, an organ of state must, in the tender documents, stipulate in the case of—

- (a) an invitation for tender for income-generating contracts, that either the 80/20 or 90/10 preference point system will apply and that the highest acceptable tender will be used to determine the applicable preference point system; or

BID DESCRIPTION: APPOINTMENT OF ONE SERVICE PROVIDER FOR SUPPLY AND DELIVERY OF TICKETING MATERIAL (PITIX ROLLS, ITIX ROLLS AND RIBBONS) ON AS AND WHEN BASIS FOR A PERIOD OF 36 MONTHS AT PRASA IN THE EASTERN CAPE REGION (ECR)	 prasa <small>PASSENGER RAIL AGENCY OF SOUTH AFRICA</small>
BID NUMBER: ECR/RAIL/ICT/01/2026	

(b) any other invitation for tender, that either the 80/20 or 90/10 preference point system will apply and that the lowest acceptable tender will be used to determine the applicable preference point system,

then the organ of state must indicate the points allocated for specific goals for both the 90/10 and 80/20 preference point system.

Table 1: Specific goals for the tender and points claimed are indicated per the table below.

(Note to organs of state: Where 80/20 preference point system is applicable, corresponding points must also be indicated as such.

Note to tenderers: The tenderer must indicate how they claim points for each preference point system.)

The specific goals allocated points in terms of this tender	Acceptable Evidence/Proof required	Number of points allocated. (80/20 system) (To be completed by the organ of state)	Number of points claimed (80/20 system) (To be completed by the tenderer)
51% Black Women Owned	Certified copy of ID Documents of the Owners	4	
51% Black Youth Owned	Certified copy of ID Documents of the Owners	4	
EME 51% Black Owned	Audited Annual Financial/ B-BBEE Certificate / Affidavit	4	
51% Black Owned	CIPC Documents / B-BBEE Certificate / Affidavit	4	
Owned by Black People with Disability (PWD)	Certified copy of ID Documents of the Owners and Doctor's note confirming the disability	4	

BID DESCRIPTION: APPOINTMENT OF ONE SERVICE PROVIDER FOR SUPPLY AND DELIVERY OF TICKETING MATERIAL (PITIX ROLLS, ITIX ROLLS AND RIBBONS) ON AS AND WHEN BASIS FOR A PERIOD OF 36 MONTHS AT PRASA IN THE EASTERN CAPE REGION (ECR)	
BID NUMBER: ECR/RAIL/ICT/01/2026	

1 APPOINTMENTS OTHER THAN THE SUCCESSFUL BIDDER

- 1.1 PRASA may appoint a bidder other than the successful bidder under the following instances:
- (i) When a successful bidder, after having been informed of the acceptance of its Bid, fails to sign a contract within a prescribe period of time e.g. 14 (fourteen) days after being called upon to do so;
 - (ii) When a successful bidder has failed to provide the necessary security, bonds or guarantees within the time required to do so by PRASA;
 - (iii) When a successful bidder fails to meet a condition precedent for the award of business (e.g. to obtain the necessary funding); and
 - (iv) When final contract negotiations with a preferred bidder fails and a contract is not agreed upon.
- 1.2 PRASA will only award a bid to a bidder other than the highest scoring bidder provided that the bid is still within the bid validity period.
- 1.3 Only if the second ranked bidder is also unable/unwilling, PRASA may proceed to the third ranked bidder.

BID DESCRIPTION: APPOINTMENT OF ONE SERVICE PROVIDER FOR SUPPLY AND DELIVERY OF TICKETING MATERIAL (PITIX ROLLS, ITIX ROLLS AND RIBBONS) ON AS AND WHEN BASIS FOR A PERIOD OF 36 MONTHS AT PRASA IN THE EASTERN CAPE REGION (ECR)	 prasa <small>PASSENGER RAIL AGENCY OF SOUTH AFRICA</small>
BID NUMBER: ECR/RAIL/ICT/01/2026	

8. VALIDITY PERIOD

This RFP shall be valid for *[90 working days]* calculated from Bid closing date.

9. THE NATIONAL INDUSTRIAL PARTICIPATION PROGRAMME

9.1 National Industrial Participation Programme (NIPP) requirements:

The National Industrial Participation (NIP) Programme, which is applicable to all government procurement contracts that have an imported content, became effective on the 1 September 1996. The NIP policy and guidelines were fully endorsed by Cabinet on 30 April 1997. In terms of the Cabinet decision, all state and parastatal purchases / lease contracts (for goods, works and services) entered into after this date, are subject to the NIP requirements. NIP is obligatory and therefore must be complied with. The Industrial Participation Secretariat (IPS) of the Department of Trade and Industry (DTI) is charged with the responsibility of administering the programme. (delete if not applicable)

Bidders are therefore required to complete SBD 5 to give effect to the above.

10. POST TENDER NEGOTIATION (IF APPLICABLE)

PRASA reserves the right to conduct post tender negotiations with a shortlist of Bidder(s). The shortlist could comprise of one or more Bidders. Should PRASA conduct post tender negotiations, Bidders will be requested to provide their best and final offers to PRASA based on such negotiations. A final evaluation will be conducted in terms of 80/20 or / 90/10.

11. FINAL CONTRACT AWARD

PRASA will negotiate the final terms and condition the contract with the successful Bidder(s). This may include aspects such as Enterprise Development and Supplier Development, the B-BBEE Improvement Plan, price and delivery. Thereafter the final contract will be awarded to the successful Bidder(s).

BID DESCRIPTION: APPOINTMENT OF ONE SERVICE PROVIDER FOR SUPPLY AND DELIVERY OF TICKETING MATERIAL (PITIX ROLLS, ITIX ROLLS AND RIBBONS) ON AS AND WHEN BASIS FOR A PERIOD OF 36 MONTHS AT PRASA IN THE EASTERN CAPE REGION (ECR)	
BID NUMBER: ECR/RAIL/ICT/01/2026	

12. FAIRNESS AND TRANSPARENCY

PRASA views fairness and transparency during the RFP Process as an absolute on which PRASA will not compromise. PRASA will ensure that all members of evaluation committees declare any conflicting or undue interest in the process and provide confidentiality undertakings to PRASA. The evaluation process will be tightly monitored and controlled by PRASA to assure integrity and transparency throughout, with all processes and decisions taken being approved and auditable.

BID DESCRIPTION: APPOINTMENT OF ONE SERVICE PROVIDER FOR SUPPLY AND DELIVERY OF TICKETING MATERIAL (PITIX ROLLS, ITIX ROLLS AND RIBBONS) ON AS AND WHEN BASIS FOR A PERIOD OF 36 MONTHS AT PRASA IN THE EASTERN CAPE REGION (ECR)	 prasa <small>PASSENGER RAIL AGENCY OF SOUTH AFRICA</small>
BID NUMBER: ECR/RAIL/ICT/01/2026	

SECTION 3

PRICING AND DELIVERY SCHEDULE

Bidders are required to complete the Pricing Schedule/ BOQ **Annexure: A** and Form C (Volume 2 /Envelope 2)

1 **PRICING**

- 1.1. Prices must be quoted in South African Rand, inclusive of all applicable taxes.
- 1.2. Price offer is firm and clearly indicate the basis thereof.
- 1.3. Pricing Bill of Quantity is completed in line with schedule if applicable (delete if not applicable).
- 1.4. Cost breakdown must be indicated.
- 1.5. Price escalation basis and formula must be indicated.
- 1.6. To facilitate like-for like comparison bidders must submit pricing strictly in accordance with this price schedule and not utilise a different format. Deviation from this pricing schedule could result in a bid being declared non-responsive.
- 1.7. Please note that should you have offered a discounted price(s), PRASA will only consider such price discount(s) in the final evaluation stage on an unconditional basis.
- 1.8. Bidders are to note that if price offered by the highest scoring bidder is not market related, PRASA may not award the contract to the Bidder. PRASA may:
 - 1.8.1. negotiate a market-related price with the Bidder scoring the highest points or cancel the RFP;
 - 1.8.2. if that Bidder does not agree to a market-related price, negotiate a market-related price with the Bidder scoring the second highest points or cancel the RFP; and
 - 1.8.3. if the Bidder scoring the second highest points does not agree to a market-related price, negotiate a market-related price with the Bidder scoring the third highest points or cancel the RFP.
 - 1.8.4. If a market-related price is not agreed with the Bidder scoring the third highest points, PRASA must cancel the RFP.

<p>BID DESCRIPTION: APPOINTMENT OF ONE SERVICE PROVIDER FOR SUPPLY AND DELIVERY OF TICKETING MATERIAL (PITIX ROLLS, ITIX ROLLS AND RIBBONS) ON AS AND WHEN BASIS FOR A PERIOD OF 36 MONTHS AT PRASA IN THE EASTERN CAPE REGION (ECR)</p>	
<p>BID NUMBER: ECR/RAIL/ICT/01/2026</p>	

2 DISCLOSURE OF PRICES QUOTED

Bidders are to note that, on award of business, PRASA is required to publish the tendered prices and preferences claimed of the successful and unsuccessful Bidders inter alia on the National Treasury e-Tender Publication Portal, (www.etenders.gov.za) , the other medium used to advertise the bid i.e CIDB as required per National Treasury Instruction Note 09 of 2022/2023.

3 PERFORMANCE AND BID BONDS (WHERE APPLICABLE)

3.1. The preferred Bidder shall where applicable provide PRASA with a performance bond which shall be 10% of the value of the entire Project price offered and it shall be issued with 30 days of receipt of notice of appointment. The Performance Bond shall be valid for the Contract period. The format of the Performance Bond is attached as **Annexure**

4 OWNERSHIP OF DESIGN

5 SERVICE LEVELS

5.1. An experienced national account representative(s) is required to work with PRASA’s procurement department. [No sales representatives are needed for individual department or locations]. Additionally, there shall be a minimal number of people, fully informed and accountable for this agreement.

5.2. PRASA will have quarterly reviews with the Service provider’s account representative on an on-going basis.

5.3. PRASA reserves the right to request that any member of the Service Provider’s team involved on the PRASA account be replaced if deemed not to be adding value for PRASA.

5.4. The Service provider guarantees that it will achieve a 100% [hundred per cent] service level on the following measures:

- a) Random checks on compliance with quality/quantity/specifications
- b) On time delivery.

BID DESCRIPTION: APPOINTMENT OF ONE SERVICE PROVIDER FOR SUPPLY AND DELIVERY OF TICKETING MATERIAL (PITIX ROLLS, ITIX ROLLS AND RIBBONS) ON AS AND WHEN BASIS FOR A PERIOD OF 36 MONTHS AT PRASA IN THE EASTERN CAPE REGION (ECR)	 prasa <small>PASSENGER RAIL AGENCY OF SOUTH AFRICA</small>
BID NUMBER: ECR/RAIL/ICT/01/2026	

- 5.5. The Service provider must provide a telephone number for customer service calls.
- 5.6. Failure of the Service provider to comply with stated service level requirements will give PRASA the right to cancel the contract in whole, without penalty to PRASA, giving 30 [thirty] calendar days' notice to the Service provider of its intention to do so.

Acceptance of Service Levels:

YES	
-----	--

6 TOTAL COST OF OWNERSHIP (TCO)

- 6.1. PRASA will strive to procure goods, services and works which contribute to its mission. In order to achieve this, PRASA must be committed to working with suppliers who share its goals of continuous improvement in service, quality and reduction of Total Cost of Ownership (TCO).
- 6.2. Bidders shall indicate whether they would be committed, for the duration of any contract which may be awarded through this RFP process, to participate with PRASA in its continuous improvement initiatives to reduce the total cost of ownership [TCO], which will reduce the overall cost of transportation services and related logistics provided by PRASA's operating divisions within South Africa to the ultimate benefit of all end-users.

7 FINANCIAL STABILITY

Bidders are required to submit their latest financial statements prepared and signed off by a professional accountant for the past years with their Proposal in order to enable PRASA to establish financial stability.

SIGNED at _____ on this ____ day of _____ 20.....

SIGNATURE OF WITNESSES

ADDRESS OF WITNESSES

1 _____

BID DESCRIPTION: APPOINTMENT OF ONE SERVICE PROVIDER FOR SUPPLY AND DELIVERY OF TICKETING MATERIAL (PITIX ROLLS, ITIX ROLLS AND RIBBONS) ON AS AND WHEN BASIS FOR A PERIOD OF 36 MONTHS AT PRASA IN THE EASTERN CAPE REGION (ECR)



BID NUMBER: ECR/RAIL/ICT/01/2026

Name _____

2 _____

Name _____

SIGNATURE OF BIDDER'S AUTHORISED REPRESENTATIVE: _____

NAME: _____

DESIGNATION: _____

BID DESCRIPTION: APPOINTMENT OF ONE SERVICE PROVIDER FOR SUPPLY AND DELIVERY OF TICKETING MATERIAL (PITIX ROLLS, ITIX ROLLS AND RIBBONS) ON AS AND WHEN BASIS FOR A PERIOD OF 36 MONTHS AT PRASA IN THE EASTERN CAPE REGION (ECR)	 prasa <small>PASSENGER RAIL AGENCY OF SOUTH AFRICA</small>
BID NUMBER: ECR/RAIL/ICT/01/2026	

8 VALIDITY OF RETURNABLE DOCUMENTS

The successful Bidder will be required to ensure the validity of all returnable documents, including but not limited to its Tax Clearance Certificate and valid B-BBEE Verification Certificate, for the duration of any contract emanating from this RFP. Should the Bidder be awarded the contract [the Agreement] and fail to present PRASA with such renewals as and when they become due, PRASA shall be entitled, in addition to any other rights and remedies that it may have in terms of the eventual Agreement, to terminate such Agreement forthwith without any liability and without prejudice to any claims which PRASA may have for damages against the Bidder.

SIGNED at _____ on this ____ day of _____ 20.....

SIGNATURE OF WITNESSES

ADDRESS OF WITNESSES

1 _____

Name _____

2 _____

Name _____

SIGNATURE OF BIDDER'S AUTHORISED REPRESENTATIVE: _____

NAME: _____

DESIGNATION: _____

BID DESCRIPTION: APPOINTMENT OF ONE SERVICE PROVIDER FOR SUPPLY AND DELIVERY OF TICKETING MATERIAL (PITIX ROLLS, ITIX ROLLS AND RIBBONS) ON AS AND WHEN BASIS FOR A PERIOD OF 36 MONTHS AT PRASA IN THE EASTERN CAPE REGION (ECR)	 prasa <small>PASSENGER RAIL AGENCY OF SOUTH AFRICA</small>
BID NUMBER: ECR/RAIL/ICT/01/2026	

9 CERTIFICATE OF ACQUAINTANCE WITH RFP TERMS & CONDITIONS & APPLICABLE DOCUMENTS

By signing this certificate the Bidder is deemed to acknowledge that he/she has made himself/herself thoroughly familiar with, and agrees with all the conditions governing this RFP, including those contained in any printed form stated to form part hereof, including but not limited to the documents stated below and PRASA will recognise no claim for relief based on an allegation that the Bidder overlooked any such condition or failed properly to take it into account for the purpose of calculating tendered prices or any other purpose:

- | |
|--------------------------------------------------------------------------------------------|
| 1. PRASA’s General Bid Conditions* |
| 2. Standard RFP Terms and Conditions for the supply of Goods or Services or Works to PRASA |

Should the Bidder find any terms or conditions stipulated in any of the relevant documents quoted in the RFP unacceptable, it should indicate which conditions are unacceptable and offer alternatives by written submission on its company letterhead, attached to its submitted Bid. Any such submission shall be subject to review by PRASA’s Legal Counsel who shall determine whether the proposed alternative(s) are acceptable or otherwise, as the case may be. A material deviation from the Standard terms or conditions could result in disqualification.

Bidders accept that an obligation rests on them to clarify any uncertainties regarding any bid to which they intend to respond, before submitting the bid. The Bidder agrees that he/she will have no claim based on an allegation that any aspect of this RFP was unclear but in respect of which he/she failed to obtain clarity.

The bidder understands that his/her Bid will be disqualified if this Certificate of Acquaintance with RFP documents included in the RFP as a returnable document, is found not to be true and complete in every respect.

SIGNED at _____ on this _____ day of _____ 20.....

SIGNATURE OF WITNESSES

ADDRESS OF WITNESSES

1 _____

BID DESCRIPTION: APPOINTMENT OF ONE SERVICE PROVIDER FOR SUPPLY AND DELIVERY OF TICKETING MATERIAL (PITIX ROLLS, ITIX ROLLS AND RIBBONS) ON AS AND WHEN BASIS FOR A PERIOD OF 36 MONTHS AT PRASA IN THE EASTERN CAPE REGION (ECR)	 prasa <small>PASSENGER RAIL AGENCY OF SOUTH AFRICA</small>
BID NUMBER: ECR/RAIL/ICT/01/2026	

Name _____

SIGNATURE OF BIDDER'S AUTHORISED REPRESENTATIVE: _____

NAME: _____

DESIGNATION: _____

BID DESCRIPTION: APPOINTMENT OF ONE SERVICE PROVIDER FOR SUPPLY AND DELIVERY OF TICKETING MATERIAL (PITIX ROLLS, ITIX ROLLS AND RIBBONS) ON AS AND WHEN BASIS FOR A PERIOD OF 36 MONTHS AT PRASA IN THE EASTERN CAPE REGION (ECR)	 prasa <small>PASSENGER RAIL AGENCY OF SOUTH AFRICA</small>
BID NUMBER: ECR/RAIL/ICT/01/2026	

10 GENERAL CONDITIONS

10.1 ALTERNATIVE BIDS

Bidders may submit alternative Bid only if a main Bid, strictly in accordance with all the requirements of the RFP is also submitted. The alternative Bid is submitted with the main Bid together with a schedule that compares the requirements of the RFP with the alternative requirements the Bidders proposes. Bidders must note that in submitting an alternative Bid they accept that PRASA may accept or reject the alternative Bid and shall be evaluated in accordance with the criteria stipulated in this RFP.

10.2 PRASA'S TENDER FORMS

Bidders must sign and complete the PRASA's Bid Forms and attach all the required documents. Failure by Bidders to adhere to this requirement may lead to their disqualification.

10.3 PRECEDENT

In case of any conflict with this RFP and Bidders response, this RFP and its briefing notes shall take precedence.

10.4 RESPONSE TO RFP-CONFIDENTIALITY

Response to RFPs must clearly indicate whether any information conveyed to or requested from PRASA is confidential or should be treated confidentially by PRASA. In the absence of any such clear indication in writing from a response to RFP, PRASA shall deem the response to RFP to have waived any right to confidentiality and treat such information as public in nature.

Where a Bidder at any stage during the RFP Process indicates to PRASA that information or any response to RFP requested from PRASA is or should be treated confidentially, PRASA shall treat such information or response to RFP confidentially, unless PRASA believes that to ensure the transparency and competitiveness of the RFP Process the content of the information or response to RFP should be conveyed to all Bidders, in which event it shall apply the following process:

- PRASA shall confirm with the Bidder whether the raising of confidentiality applies to the entire response to the RFP or only specific elements or sections of the response;

BID DESCRIPTION: APPOINTMENT OF ONE SERVICE PROVIDER FOR SUPPLY AND DELIVERY OF TICKETING MATERIAL (PITIX ROLLS, ITIX ROLLS AND RIBBONS) ON AS AND WHEN BASIS FOR A PERIOD OF 36 MONTHS AT PRASA IN THE EASTERN CAPE REGION (ECR)	
BID NUMBER: ECR/RAIL/ICT/01/2026	

- Where confidentiality is maintained by the Bidder and PRASA is of the opinion that the information or response to RFP if made publicly available would affect the commercial interests of the Bidder or is commercially sensitive information, PRASA shall not release such information to other Bidders if providing such information or response to the RFP would prejudice the competitiveness and transparency of the RFP Process;
- Where PRASA is of the opinion that information provided is not commercially sensitive or would have no impact on the commercial interests of the relevant Bidder if released and fairness and transparency requires that such information be released to all Bidders, PRASA may:
 - i. inform the relevant Bidder of the necessity to release such information and/or response to RFP and request the Bidder to consent to the release thereof by PRASA; or
 - ii. obtain legal advice regarding the confidentiality of the relevant information and/or response to RFP and the legal ability of PRASA to release such information; or
 - iii. refrain from releasing the information and/or response to RFP, in which event PRASA shall not take account of the contents of such information in the evaluation of the relevant response to RFP.

The above procedures regarding confidentiality shall not apply to any information which is already public knowledge or available in the public domain or in the hands of PRASA or is required to be disclosed by any legal or regulatory requirements or order of any competent court, tribunal or forum.

10.5 RESPONSE TO THE RFP – RFP DISQUALIFICATION

Responses to RFP which do not comply with the RFP requirements, formalities, terms and conditions may be disqualified by PRASA from further participation in the RFP Process.

In particular (but without prejudice to the generality of the foregoing) PRASA may disqualify, at its sole discretion and without prejudice to any other remedy it may have, a Bidder where the Bidder, or any of its consortium members, subcontractors or advisors have committed any act of misrepresentation, bad faith or dishonest conduct in any of its dealings with or information provided to PRASA.

10.6 CORRUPTION, GIFTS AND PAYMENTS

Neither the Bidders to RFPs, its equity members, the sub-contractors, consortium members nor any of their agents, lenders or advisors shall directly or indirectly offer or give to any person in the employment

BID DESCRIPTION: APPOINTMENT OF ONE SERVICE PROVIDER FOR SUPPLY AND DELIVERY OF TICKETING MATERIAL (PITIX ROLLS, ITIX ROLLS AND RIBBONS) ON AS AND WHEN BASIS FOR A PERIOD OF 36 MONTHS AT PRASA IN THE EASTERN CAPE REGION (ECR)	 prasa <small>PASSENGER RAIL AGENCY OF SOUTH AFRICA</small>
BID NUMBER: ECR/RAIL/ICT/01/2026	

of PRASA or any other Government official or any of the Advisory Team any gift or consideration of any kind as an inducement or reward for appointing a particular Bidder, or for showing or omitting to show favour or disfavour to any of the Bidders, its equity members or the sub-contractors in relation to the Project.

In the event that any of the prohibited practices contemplated under the above paragraph is committed, PRASA shall be entitled to terminate any Response to RFP's status and to prohibit such Response to RFP, its equity members, its SPV members, its Sub Contractors and their agents, lenders and advisors from participating in any further part of the procurement of the Project.

10.7 INSURANCE

Unless specifically provided for in this RFP or draft contracts, Bidders will be required to submit with their Bid for services professional indemnity insurance and works insurance to an extent (if any) if insurance provided by PRASA may not be for the full cover required in terms of the relevant category listed in this RFP. The Bidder is advised to seek qualified advice regarding insurance.

10.8 NO CONTACT POLICY

Bidders may only contact the bid administrator of PRASA as per the terms of the Communication Structure established by this RFP, except in the case of pre-existing commercial relationships, in which case contact may be maintained only with respect thereto and, in making such contact, no party may make reference to the Project or this RFP.

10.9 CONFLICT OF INTEREST

No Bidder member, subcontractor or advisor of the response to RFP may be a member of or in any other way participate or be involved, either directly or indirectly in more than one response to RFP or response to RFP during any stage of the Project procurement process, but excluding specialist suppliers of systems and equipment, non-core service providers or financial or commercial institutions whose role is limited purely to lending money or advancing credit to the response to RFP. Bidders are to sign the declaration of interest form. In order to prevent the conflict or potential conflict of interest between Lenders and Bidders to RFP, no advisors or the Contractor/s or Consortium/s to any response to RFP, consortium member or subcontractor may fulfil the role of arranger, underwriter and/or lead bank to the response to RFP. PRASA may disqualify the response to RFP from further participation in the event of a failure to comply with this provision. PRASA views the potential conflict of interest so great as to warrant the reduction of competition for advisory services.

BID DESCRIPTION: APPOINTMENT OF ONE SERVICE PROVIDER FOR SUPPLY AND DELIVERY OF TICKETING MATERIAL (PITIX ROLLS, ITIX ROLLS AND RIBBONS) ON AS AND WHEN BASIS FOR A PERIOD OF 36 MONTHS AT PRASA IN THE EASTERN CAPE REGION (ECR)	 prasa <small>PASSENGER RAIL AGENCY OF SOUTH AFRICA</small>
BID NUMBER: ECR/RAIL/ICT/01/2026	

10.10 BIDDER’S DECLARATION REGARDING PEP/PIP

PRASA requires bidders to disclose if they have Politically Exposed Persons (“PEP”)¹ or Prominent Influential Persons (“PIP”)² and related individuals in their organisation and/or beneficial owners / shareholders who are PEP/PIP.

PRASA reserves the right not to enter into a business relationship with such person, official or entity, provided there are objective factors that justify the conclusion of such business relationship, and the decision is based on achieving the best interest of PRASA.³

- 10.10.1 Is the bidder a PEP/PIP? **YES/NO**
- 10.10.2 Does the bidder have an existing relationship with a PEP/PIP? **YES/NO**

10.10.3 Where a relationship with a PEP/PIP exists, the bidder is required to furnish particulars of the nature of the exposure, term of the office and description of activities relating to exposure, in table below.

Name of PEP/PIP & Nature of Exposure/Influence	Term of the office	Description of activities relating to Exposure/Influence

10.10.4 Declaration:

I/We the undersigned _____
(Name) hereby certify that the PEP/PIP information furnished in this bid document is true and correct. We further certify that we understand that where it is found that we have made a false declaration or statement in this bid, PRASA may disqualify our bid or terminate a contract we may have with PRASA where we are successful in this tender.

¹Both foreign and domestic politically exposed person as specified in Schedule 3A and 3B of the Financial Intelligence Centre Act No. 38 of 2001 as amended. (refer to Annexure 2 of the PRASA Code of Conduct for dealing with Politically Exposed Persons, Prominent Influential Persons and Related Parties).

²As reflected in Schedule 3C of the Financial Intelligence Centre Act No.38 of 2001 (refer to Annexure 2.1.2 of the PRASA Code of Conduct for dealing with Politically Exposed Persons, Prominent Influential Persons and Related Parties).

³Clause 4.5 of the PRASA Code of Conduct for dealing with Politically Exposed Persons, Prominent Influential Persons and Related Parties.

BID DESCRIPTION: APPOINTMENT OF ONE SERVICE PROVIDER FOR SUPPLY AND DELIVERY OF TICKETING MATERIAL (PITIX ROLLS, ITIX ROLLS AND RIBBONS) ON AS AND WHEN BASIS FOR A PERIOD OF 36 MONTHS AT PRASA IN THE EASTERN CAPE REGION (ECR)	 prasa <small>PASSENGER RAIL AGENCY OF SOUTH AFRICA</small>
BID NUMBER: ECR/RAIL/ICT/01/2026	

Signature

Date

Position

Name of bidder

10.11 COLLUSION AND CORRUPTION

Any Bidder shall, without prejudice to any other remedy available to PRASA, be disqualified, where the response to RFP –

- communicates to a person other than persons nominated by PRASA a material part of its response to RFP; or
- Enters into any Contract or arrangement with any other person or entity that it shall refrain from submitting a response to RFP to this RFP or as to any material part of its Response to RFP to this RFP (refer the prohibition contained in Section 4(1)(b)(iii) of the Competition Act 89 of 1998).
 . The Bidders represents that the Bidder has not, directly or indirectly, entered into any agreement, arrangement or understanding or any such like for the purpose of, with the intention to, enter into collusive Biding or with reasonable appreciation that, collusive any agreement, arrangement or understanding or any such like may result in or have the effect of collusive Biding. The Bidder undertakes that in the process of the Bid but prior to PRASA awarding the Bid to a preferred bidder become involved in or be aware of or do or caused to be done any agreement, arrangement or understanding or any such like for the purpose of or which may result in or have the effect of a collusive Bid, the Bidder will notify PRASA of such any agreement, arrangement or understanding or any such like.; or
- offers or agrees to pay or give any sum of money, inducement or valuable consideration directly or indirectly to any person for doing or having done, or causing, or having caused to be done any act or omission in relation to the RFP Process or any proposed response to RFP (provided nothing contained in this paragraph shall prevent a response to RFP from paying any market-related commission or bonus to its employees or contractors within the agreed terms of their employment or contract).

BID DESCRIPTION: APPOINTMENT OF ONE SERVICE PROVIDER FOR SUPPLY AND DELIVERY OF TICKETING MATERIAL (PITIX ROLLS, ITIX ROLLS AND RIBBONS) ON AS AND WHEN BASIS FOR A PERIOD OF 36 MONTHS AT PRASA IN THE EASTERN CAPE REGION (ECR)	
BID NUMBER: ECR/RAIL/ICT/01/2026	

10.2 CONSORTIUM CHANGES

If exceptional circumstances should arise in which a after the submission to the bid and after closing date of submission of bids, there is change in the composition of the Bidder, either through substitution or omission of any member of the Bidder:

- The Response to RFP must notify PRASA in writing of the proposed changes supported by complete details of the material reasons for the changes, the parties impacted by the changes and the impact on the response to RFP.
- PRASA shall evaluate the reasons advanced by the Bidder for the requested changes to the Bidder structure and where PRASA is not satisfied that the reasons advanced are reasonable or material, refuse to accept the change and disqualify the response to RFP, or notify the Bidder in writing of its non-acceptance of the changes and require the Bidder to propose a suitable alternative to PRASA within 10 (TEN) days of its receipt of the decision of PRASA, upon receipt of which PRASA shall -
 - i. Evaluate the alternative proposed for suitability to PRASA, and where the alternative is accepted by PRASA, inform the Bidder in writing of such acceptance and PRASA shall reassess the response to RFP against the RFP requirements and criteria; or
 - ii. Where the alternative is not accepted by PRASA, inform the Bidder in writing of such non-acceptance as well as its disqualification from the RFP Process.
 - iii. Where PRASA is satisfied that the changes requested under (i) above are reasonable and material, the response to RFP, shall be allowed to effect the required changes and PRASA shall reassess the response to RFP against the RFP requirements and criteria.

10.3 COSTS OF RESPONSE TO THE RFP SUBMISSION

All costs and expenses associated with or incurred by the Bidder in relation to any stage of the Project, shall be borne by the Bidder. PRASA shall not be liable for any such costs or expenses or any claim for reimbursement of such costs or expenses.

To avoid doubt, PRASA shall not be liable for any samples submitted by the Bidder in support of their Responses to RFP and reserves the right not to return to them such samples and to dispose of them at its discretion.

10.4 RESPONSE TO THE RFP WARRANTY

Bidders must provide a warranty as part of their Responses to RFP that their Responses to RFP are true and correct in all respects, that it does not contain a misrepresentation of any kind and that the

BID DESCRIPTION: APPOINTMENT OF ONE SERVICE PROVIDER FOR SUPPLY AND DELIVERY OF TICKETING MATERIAL (PITIX ROLLS, ITIX ROLLS AND RIBBONS) ON AS AND WHEN BASIS FOR A PERIOD OF 36 MONTHS AT PRASA IN THE EASTERN CAPE REGION (ECR)	
BID NUMBER: ECR/RAIL/ICT/01/2026	

taxes of all members of the Bidder company, consortium members and or subcontractors are in order and none of the members are undergoing corruption or any criminal-related investigations or have any past convictions for fraud or corruption.

11 CONDITIONS OF TENDER

General

- | | | |
|------------------------------------------------------|---|------------------------------------------------------------------------------------------------------------------------------------------------------------------------------------------------------------------------------------------------------------------------------------------------------------------------------------------------------------------|
| Actions | 1 | PRASA's <i>Representative</i> and each <i>tenderer</i> submitting a tender shall act as stated in these Conditions of Tender and in a manner which is fair, equitable, transparent, competitive and cost-effective. |
| Interpretation | 2 | Terms shown in <i>italics</i> vary for each tender. The details of each term for this tender are identified in the Request for Tender / Scope of work/ specification. Terms shown in capital initials are defined terms in the appropriate conditions of contract. |
| | 3 | Any additional or amended requirements in the Scope of work/ specification, and additional requirements given in the Schedules in the <i>tender returnables</i> are deemed to be part of these Conditions of Tender. |
| | 4 | The Conditions of Tender and the Scope of work/ specification shall form part of any contract arising from this invitation to tender. |
| Communication | 5 | Each communication between PRASA and a <i>tenderer</i> shall be to or from PRASA's <i>Representative</i> only, and in a form that can be read, copied and recorded. Communication shall be in the English language. PRASA takes no responsibility for non-receipt of communications from or by a <i>tenderer</i> . |
| PRASA's rights to accept or reject any tender | 6 | PRASA may accept or reject any variation, deviation, tender, or alternative tender, and may cancel the tender process and reject all tenders at any time prior to the formation of a contract. PRASA or PRASA's <i>Representative</i> will not accept or incur any liability to a <i>tenderer</i> for such cancellation and rejection, but will give reasons for |

BID DESCRIPTION: APPOINTMENT OF ONE SERVICE PROVIDER FOR SUPPLY AND DELIVERY OF TICKETING MATERIAL (PITIX ROLLS, ITIX ROLLS AND RIBBONS) ON AS AND WHEN BASIS FOR A PERIOD OF 36 MONTHS AT PRASA IN THE EASTERN CAPE REGION (ECR)	 prasa <small>PASSENGER RAIL AGENCY OF SOUTH AFRICA</small>
BID NUMBER: ECR/RAIL/ICT/01/2026	

the action. PRASA reserves the right to accept the whole or any part of any tender.

- 7 After the cancellation of the tender process or the rejection of all tenders PRASA may abandon the proposed work and services, have it performed in any other manner, or re-issue a similar invitation to tender at any time.

Tenderer's obligations

The *tenderer* shall comply with the following obligations when submitting a tender and shall:

- | | | |
|-----------------------------------------------------------|---|-------------------------------------------------------------------------------------------------------------------------------------------------------------------------------------------------------------------------------------|
| Eligibility | 1 | Submit a tender only if the <i>tenderer</i> complies with the criteria stated in the Scope of work/ specification. |
| Cost of tendering | 2 | Accept that PRASA will not compensate the <i>tenderer</i> for any costs incurred in the preparation and submission of a tender. |
| Check documents | 3 | Check the <i>tender documents</i> on receipt, including pages within them, and notify PRASA's <i>Representative</i> of any discrepancy or omissions in writing. |
| Copyright of documents | 4 | Use and copy the documents provided by PRASA only for the purpose of preparing and submitting a tender in response to this invitation. |
| Standardised specifications and other publications | 5 | Obtain, as necessary for submitting a tender, copies of the latest revision of standardised specifications and other publications, which are not attached but which are incorporated into the <i>tender documents</i> by reference. |
| Acknowledge receipt | 6 | Preferably complete the Receipt of invitation to submit a tender form attached to the Letter of Invitation and return it within five days of receipt of the invitation. |
| | 7 | Acknowledge receipt of Addenda / Tender Briefing Notes to the <i>tender documents</i> , which PRASA's <i>Representative</i> may issue, and if |

BID DESCRIPTION: APPOINTMENT OF ONE SERVICE PROVIDER FOR SUPPLY AND DELIVERY OF TICKETING MATERIAL (PITIX ROLLS, ITIX ROLLS AND RIBBONS) ON AS AND WHEN BASIS FOR A PERIOD OF 36 MONTHS AT PRASA IN THE EASTERN CAPE REGION (ECR)	 prasa <small>PASSENGER RAIL AGENCY OF SOUTH AFRICA</small>
BID NUMBER: ECR/RAIL/ICT/01/2026	

necessary apply for an extension to the *deadline for tender submission*, in order to take the Addenda into account.

- | | | |
|--------------------------------------------------|----|---------------------------------------------------------------------------------------------------------------------------------------------------------------------------------------------------------------------------------------------------------------------------------------------------------------------------------------------|
| Site visit and / or clarification meeting | 8 | Attend a site visit and/or clarification meeting at which <i>tenderers</i> may familiarise themselves with the proposed work, services or supply, location, etc. and raise questions, if provided for in the Scope of work/ specification. Details of the meeting are stated in the RFP document, <i>i-tender</i> website and CIDB website. |
| Seek clarification | 9 | Request clarification of the <i>tender documents</i> , if necessary, by notifying PRASA's <i>Representative</i> earlier than the <i>closing time for clarification of queries</i> . |
| Insurance | 10 | Be informed of the risk that needs to be covered by insurance policy. The <i>tenderer</i> is advised to seek qualified advice regarding insurance. |
| Pricing the tender | 11 | Include in the rates, prices, and the tendered total of the prices (if any) all duties, taxes (except VAT), and other levies payable by the successful <i>tenderer</i> . Such duties, taxes and levies are those applicable 14 days prior to the <i>deadline for tender submission</i> . |
| | 12 | Show Value Added Tax (VAT) payable by PRASA separately as an addition to the tendered total of the prices. |
| | 13 | Provide rates and prices that are fixed for the duration of the contract and not subject to adjustment except as provided for in the <i>conditions of contract</i> . |
| | 14 | State the rates and Prices in South African Rand unless instructed otherwise as an additional condition in the Scope of work/ specification. The selected <i>conditions of contract</i> may provide for part payment in other currencies. |
| Alterations to documents | 15 | Not make any alterations or an addition to the tender documents, except to comply with instructions issued by PRASA's <i>Representative</i> or if necessary to correct errors made by the <i>tenderer</i> . All such alterations shall be initialled by all signatories to the tender. |

BID DESCRIPTION: APPOINTMENT OF ONE SERVICE PROVIDER FOR SUPPLY AND DELIVERY OF TICKETING MATERIAL (PITIX ROLLS, ITIX ROLLS AND RIBBONS) ON AS AND WHEN BASIS FOR A PERIOD OF 36 MONTHS AT PRASA IN THE EASTERN CAPE REGION (ECR)	 prasa <small>PASSENGER RAIL AGENCY OF SOUTH AFRICA</small>
BID NUMBER: ECR/RAIL/ICT/01/2026	

Corrections may not be made using correction fluid, correction tape or the like.

- | | | |
|---------------------|----|------------------------------------------------------------------------------------------------------------------------------------------------------------------------------------------------------------------------------------------------------------------------------------------------------------------------------------------------------------------------------------------------------------------------------------------------------------------------------------|
| Alternative tenders | 16 | Submit alternative tenders only if a main tender, strictly in accordance with all the requirements of the <i>tender documents</i> is also submitted. The alternative tender is submitted with the main tender together with a schedule that compares the requirements of the <i>tender documents</i> with the alternative requirements the <i>tenderer</i> proposes. |
| | 17 | Accept that an alternative tender may be based only on the criteria stated in the Scope of work/ specification and as acceptable to PRASA. |
| Submitting a tender | 18 | Submit a tender for providing the whole of the works, services or supply identified in the Contract Data unless stated otherwise as an additional condition in the Scope of work/ specification. |
| NOTE: | 19 | Return the completed and signed <i>PRASA Tender Forms and SBD forms provided with the tender. <u>Failure to submit all the required documentation will lead to disqualification</u></i> |
| | 20 | Submit the <u>tender as an original</u> plus 1 copy and an electronic version which should be contained in Memory Cards clearly marked in the Bidders name as stated in the RFP and provide an English translation for documentation submitted in a language other than English. Tenders may not be written in pencil but must be completed in ink. |
| | 21 | Sign and initial the original and all copies of the tender where indicated. PRASA will hold the signatory duly authorised and liable on behalf of the <i>tenderer</i> . |
| | 22 | Seal the original and each copy of the tender as separate packages marking the packages as "ORIGINAL" and "COPY". Each package shall state on the outside PRASA's address and invitation to tender number stated in the Scope of work/ specification, as well as the <i>tenderer's</i> name and contact address . Where the tender is based on a two envelop system tenderers should further indicate in the package whether the document is envelope / box 1 or 2 . |

BID DESCRIPTION: APPOINTMENT OF ONE SERVICE PROVIDER FOR SUPPLY AND DELIVERY OF TICKETING MATERIAL (PITIX ROLLS, ITIX ROLLS AND RIBBONS) ON AS AND WHEN BASIS FOR A PERIOD OF 36 MONTHS AT PRASA IN THE EASTERN CAPE REGION (ECR)	
BID NUMBER: ECR/RAIL/ICT/01/2026	

- 23 Seal original and copies together in an outer package that states on the outside only PRASA's address and invitation to tender number as stated in the Scope of work/ specification. The outer package should be marked "CONFIDENTIAL"
- 24 Accept that PRASA will not assume any responsibility for the misplacement or premature opening of the tender if the outer package is not sealed and marked as stated.

Note:

PRASA prefers not to receive tenders by post, and takes no responsibility for delays in the postal system or in transit within or between PRASA offices.

PRASA prefers not to receive tenders by fax, PRASA takes no responsibility for difficulties in transmission caused by line or equipment faults.

Where tenders are sent via courier, PRASA takes no responsibility for tenders delivered to any other site than the tender office.

PRASA employees are not permitted to deposit a tender into the PRASA tender box on behalf of a tenderer, except those lodged by post or courier.

Closing time

- 25 Ensure that PRASA has received the tender at the stated address with the Scope of work / specification no later than the *deadline for tender submission*. Proof of posting will not be taken by PRASA as proof of delivery. PRASA will not accept a tender submitted telephonically, by Fax, E-mail or by telegraph unless stated otherwise in the Scope of work/ specification.
- 26 Accept that, if PRASA extends the *deadline for tender submission* for any reason, the requirements of these Conditions of Tender apply equally to the extended deadline.

BID DESCRIPTION: APPOINTMENT OF ONE SERVICE PROVIDER FOR SUPPLY AND DELIVERY OF TICKETING MATERIAL (PITIX ROLLS, ITIX ROLLS AND RIBBONS) ON AS AND WHEN BASIS FOR A PERIOD OF 36 MONTHS AT PRASA IN THE EASTERN CAPE REGION (ECR)	
BID NUMBER: ECR/RAIL/ICT/01/2026	

- | | |
|-------------------------------------------------|---------------------------------------------------------------------------------------------------------------------------------------------------------------------------------------------------------------------------------------------------------------------------------------------------------------------------------------------------------------------------------------------------------------------------------------------------------------------------------------------------------------------------------------------------------------------------------------------------------------------------------------------------|
| Tender validity | 27 Hold the tender(s) valid for acceptance by PRASA at any time within the <i>validity period</i> after the <i>deadline for tender submission</i> . |
| | 28 Extend the <i>validity period</i> for a specified additional period if PRASA requests the <i>tenderer</i> to extend it. A <i>tenderer</i> agreeing to the request will not be required or permitted to modify a tender, except to the extent PRASA may allow for the effects of inflation over the additional period. |
| Clarification of tender after submission | 29 Provide clarification of a tender in response to a request to do so from PRASA's <i>Representative</i> during the evaluation of tenders. This may include providing a breakdown of rates or Prices. No change in the total of the Prices or substance of the tender is sought, offered, or permitted except as required by PRASA's <i>Representative</i> to confirm the correction of arithmetical errors discovered in the evaluation of tenders. The total of the Prices stated by the <i>tenderer</i> as corrected by PRASA's <i>Representative</i> with the concurrence of the <i>tenderer</i> , shall be binding upon the <i>tenderer</i> |
| Submit bonds, policies etc. | 30 If instructed by PRASA's <i>Representative</i> (before the formation of a contract), submit for PRASA's acceptance, the bonds, guarantees, policies and certificates of insurance required to be provided by the successful <i>tenderer</i> in terms of the <i>conditions of contract</i> . |
| | 31 Undertake to check the final draft of the contract provided by PRASA's <i>Representative</i> , and sign the Form of Agreement all within the time required. |
| | 32 Where an agent on behalf of a principal submits a tender, an authenticated copy of the authority to act as an agent should be submitted with the tender. |
| Fulfil BEE requirements | 33 Comply with PRASA's requirements regarding BBBEE Suppliers. |

BID DESCRIPTION: APPOINTMENT OF ONE SERVICE PROVIDER FOR SUPPLY AND DELIVERY OF TICKETING MATERIAL (PITIX ROLLS, ITIX ROLLS AND RIBBONS) ON AS AND WHEN BASIS FOR A PERIOD OF 36 MONTHS AT PRASA IN THE EASTERN CAPE REGION (ECR)	
BID NUMBER: ECR/RAIL/ICT/01/2026	

PRASA'S UNDERTAKINGS

PRASA, and PRASA's *Representative*, shall:

- | | | |
|---------------------------------|---|----------------------------------------------------------------------------------------------------------------------------------------------------------------------------------------------------------------------------------------------------------------------------------------------------------------------------------------------------------------------------------------------------------------------------------------------------------------------------------------------------------------------------------------------------|
| Respond to clarification | 1 | Respond to a request for clarification received earlier than the <i>closing time for clarification of queries</i> . The response is notified to all <i>tenderers</i> . |
| Issue Addenda | 2 | If necessary, issue to each <i>tenderer</i> from time to time during the period from the date of the Letter of Invitation until the <i>closing time for clarification of queries</i> , Addenda that may amend, amplify, or add to the <i>tender documents</i> . If a <i>tenderer</i> applies for an extension to the <i>deadline for tender submission</i> , in order to take Addenda into account in preparing a tender, PRASA may grant such an extension and PRASA's <i>Representative</i> shall notify the extension to all <i>tenderers</i> . |
| Return late tenders | 3 | Return tenders received after the <i>deadline for tender submission</i> unopened to the <i>tenderer</i> submitting a late tender. Tenders will be deemed late if they are not in the designated tender box at the date and time stipulated as the deadline for tender submission. |
| Non-disclosure | 4 | Not disclose to <i>tenderers</i> , or to any other person not officially concerned with such processes, information relating to the evaluation and comparison of tenders and recommendations for the award of a contract. |
| Grounds for rejection | 5 | Consider rejecting a tender if there is any effort by a <i>tenderer</i> to influence the processing of tenders or contract award. |
| Disqualification | 6 | Instantly disqualify a <i>tenderer</i> (and his tender) if it is established that the <i>tenderer</i> offered an inducement to any person with a view to influencing the placing of a contract arising from this invitation to tender. |
| Test for responsiveness | 7 | Determine before detailed evaluation, whether each tender properly received <ul style="list-style-type: none"> • meets the requirements of these Conditions of Tender, • has been properly signed, and • is responsive to the requirements of the <i>tender documents</i>. |

BID DESCRIPTION: APPOINTMENT OF ONE SERVICE PROVIDER FOR SUPPLY AND DELIVERY OF TICKETING MATERIAL (PITIX ROLLS, ITIX ROLLS AND RIBBONS) ON AS AND WHEN BASIS FOR A PERIOD OF 36 MONTHS AT PRASA IN THE EASTERN CAPE REGION (ECR)	 prasa <small>PASSENGER RAIL AGENCY OF SOUTH AFRICA</small>
BID NUMBER: ECR/RAIL/ICT/01/2026	

- 8 Judge a responsive tender as one which conforms to all the terms, conditions, and specifications of the *tender documents* without material deviation or qualification. A material deviation or qualification is one which, in PRASA 's opinion would
- detrimentally affect the scope, quality, or performance of the works, services or supply identified in the Contract Data,
 - change PRASA's or the *tenderer's* risks and responsibilities under the contract, or
 - affect the competitive position of other *tenderers* presenting responsive tenders, if it were to be rectified.
- Non-responsive tenders** 10 Reject a non-responsive tender, and not allow it to be subsequently made responsive by correction or withdrawal of the non-conforming deviation or reservation.
- Arithmetical errors** 11 Check responsive tenders for arithmetical errors, correcting them as follows:
- Where there is a discrepancy between the amounts in figures and in words, the amount in words shall govern.
 - If a bill of quantities applies and there is a discrepancy between the rate and the line item total, resulting from multiplying the rate by the quantity, the rate as quoted shall govern. Where there is an obviously gross misplacement of the decimal point in the rate, the line item total as quoted shall govern, and the rate will be corrected.
 - Where there is an error in the total of the Prices, either as a result of other corrections required by this checking process or in the *tenderer's* addition of prices, the total of the Prices, if any, will be corrected.
- 12 Reject a tender if the *tenderer* does not accept the corrected total of the Prices (if any).
- Evaluating the tender** 13 Evaluate responsive tenders in accordance with the procedure stated in the RFP / Scope of work/ specification. The evaluated tender price will be disclosed only to the relevant PRASA tender committee and will not be disclosed to *tenderers* or any other person.

BID DESCRIPTION: APPOINTMENT OF ONE SERVICE PROVIDER FOR SUPPLY AND DELIVERY OF TICKETING MATERIAL (PITIX ROLLS, ITIX ROLLS AND RIBBONS) ON AS AND WHEN BASIS FOR A PERIOD OF 36 MONTHS AT PRASA IN THE EASTERN CAPE REGION (ECR)	
BID NUMBER: ECR/RAIL/ICT/01/2026	

Clarification of a tender	14 Obtain from a <i>tenderer</i> clarification of any matter in the tender which may not be clear or could give rise to ambiguity in a contract arising from this tender if the matter were not to be clarified.
Acceptance of tender	15 Notify PRASA's acceptance to the successful <i>tenderer</i> before the expiry of the <i>validity period</i> , or agreed additional period. Providing the notice of acceptance does not contain any qualifying statements, it will constitute the formation of a contract between PRASA and the successful <i>tenderer</i> .
Notice to unsuccessful tenderers	16 After the successful <i>tenderer</i> has acknowledged PRASA's notice of acceptance, notify other <i>tenderers</i> that their tenders have not been accepted, following PRASA's current procedures.
Prepare contract documents	17 Revise the contract documents issued by PRASA as part of the <i>tender documents</i> to take account of: <ul style="list-style-type: none"> • Addenda issued during the tender period; • inclusion of some of the <i>tender returnables</i>; and • other revisions agreed between PRASA and the successful <i>tenderer</i>, before the issue of PRASA's notice of acceptance (of the tender).
Issue final contract	18 Issue the final contract documents to the successful <i>tenderer</i> for acceptance within one week of the date of PRASA's notice of acceptance.
Sign Form of Agreement	19 Arrange for authorised signatories of both parties to complete and sign the original and one copy of the Form of Agreement within two weeks of the date of PRASA's notice of acceptance of the tender. If either party requires the signatories to initial every page of the contract documents, the signatories for the other party shall comply with the request.
Provide copies of the contracts	20 Provide to the successful <i>tenderer</i> the number of copies stated in the Scope of work/ specification of the signed copy of the contracts within three weeks of the date of PRASA's acceptance of the tender.