

STRATEGY, OPERATIONS & COMPLIANCE

Financial Management

Tel: +27 12 845 6000 | Fax: +27 12 845 7356
 Victoria & Griffiths, Mxenge Building, 123 Westlake Avenue
 Weavind Park, Silverton, Pretoria | P/Bag X752, Pretoria,
 0001, South Africa



National Prosecuting Authority
 South Africa

INVITATION TO BID

BID DETAILS

BID NUMBER	:	NPA 01-25/26
ISSUE DATE	:	07 November 2025
CLOSING DATE	:	01 December 2025
CLOSING TIME	:	11h00 am.
BID DESCRIPTION	:	Supply, delivery and installation of Office furniture to the NPA offices.
CONTRACT DURATION	:	Three (3) years

DETAILS OF BIDDER

COMPANY NAME: _____

CSD SUPPLIER NUMBER	UNIQUE REGISTRATION NUMBER

Please indicate whether this document is an original or copy, tick the applicable block.

ORIGINAL

COPY

NOTE: AS PER NATIONAL TREASURY CIRCULAR BIDDERS ARE REQUIRED TO REGISTER THEIR COMPANIES ON THE CENTRAL SUPPLIER DATABASE (CSD) SINCE SUPPLIERS WHO ARE NOT REGISTERED MAY NOT BE AWARDED BIDS WITH EFFECT FROM THE 01 JULY 2016. [HTTPS://WWW.CSD.GOV.ZA](https://www.csd.gov.za)

FULL DETAILS OF BIDDER

COMPANY NAME : _____

CONTACT PERSON : _____

DATE : _____

E-MAIL ADDRESS : _____

TELEPHONE NUMBER : _____

CELLULAR NUMBER : _____

FAX NUMBER : _____

PHYSICAL ADDRESS : _____

POSTAL ADDRESS : _____

SIGNATURE OF BIDDER : _____

Bidder's Initial/Signature: _____

DOCUMENTS CHECK LIST

Bidders are requested to use the checklist below for documents to be submitted with a bid.

NO	DOCUMENTS	TICK
1.	Proof of registration on a Central Supplier Database registration report (CSD)	
2.	Bidder's profile	
3.	The bidder must provide a proposal indicating the proposed approach and/or methodology, project execution/implementation plan as per Section 3, paragraph 27.2	
4.	Submit one (1) or more signed reference letter/s from previous/current clients indicating client satisfaction, contract duration, contact details, project description and value of the contract as <i>per Section 3 paragraph 27.3</i>	
5.	Submit one (1) original and two (2) copies of the bid document	
6.	Letter of intent from the manufacturer	

Bidder's Initial/Signature: _____

CONTENT PAGE

Bidders are to ensure that they receive all pages of this document, which consists of the following:

Structure of Proposals

Glossary

- Section 1 : Invitation to Bid (SBD 1)
- Section 2 : General Conditions of Contract
- Section 3 : Special Conditions of the Bid
- Section 4 : Bid Submission Requirements
- Section 5 : Evaluation and Selection Process
- Section 6 : Terms of Reference
- Section 7 : Preference Point Claim Form in Terms of The Preferential Procurement Regulations 2022 (SBD 6.1)
- Section 8 : Bidder's Disclosure (SBD 4)
- Section 9 : Confirmation Form
- Section 10 : Bidder's experience
- Section 11 : Pricing Schedule

NOTE: Attached are the Office furniture and equipment – NPA NORMS AND STANDARDS

Bidder's Initial/Signature: _____

GLOSSARY

Award	Conclusion of the bid process and the final notification to the successful bidder
Bid	Written offer in a prescribed form in response to an invitation by NPA for the provision of goods, works or services
Briefing Session	A session that is held after the bid document is issued and before the closing date of the bid, during which information is shared with potential bidders.
Bidder	Organisation applying to participate in the bidding process as a potential supplier of the services as advertised in this Bid.
Dti	Department of Trade and Industry
GCC	General Conditions of Contract
IP	Intellectual Property
NIPP	National Industrial Participation Programme
NPA	National Prosecuting Authority
Original Bid	Original document signed in ink
SCM	Supply Chain Management
SBD	Standard bidding document
SLA	Service Level Agreement

Bidder's Initial/Signature: _____

Bid No: NPA 01-25/26	National Prosecuting Authority
Prepared By: Supply Chain Management Unit	
Bid Description: Supply, delivery and installation of Office furniture to the NPA offices for a period of three (3) years.	

SECTION 1

SBD 1

PART A

INVITATION TO BID

YOU ARE HEREBY INVITED TO BID FOR THE REQUIREMENTS OF THE (NAME OF DEPARTMENT/ PUBLIC ENTITY)					
BID NUMBER:	NPA 01-25/26	CLOSING DATE	01 December 2025	CLOSING TIME:	11H00
BID DESCRIPTION	Supply, delivery and installation of office furniture to the NPA offices for a period of three (3) years				
BID RESPONSE DOCUMENTS MAY BE DEPOSITED IN THE BID BOX SITUATED AT (STREET ADDRESS)					
National Prosecuting Authority					
VGM Building Weavind Park					
123 Westlake Avenue					
Silverton					
Pretoria					
BIDDING PROCEDURE ENQUIRIES MAY BE DIRECTED TO			TECHNICAL ENQUIRIES MAY BE DIRECTED TO:		
CONTACT PERSON	Kabelo Maree		CONTACT PERSON	Isaac Dhludhu	
TELEPHONE NUMBER	-		TELEPHONE NUMBER	-	
FACSIMILE NUMBER	-		FACSIMILE NUMBER	-	
E-MAIL ADDRESS	tenders@npa.gov.za		E-MAIL ADDRESS	tenders@npa.gov.za	
SUPPLIER INFORMATION					
NAME OF BIDDER					
POSTAL ADDRESS					
STREET ADDRESS					
TELEPHONE NUMBER	CODE		NUMBER		
CELLPHONE NUMBER					
FACSIMILE NUMBER	CODE		NUMBER		
E-MAIL ADDRESS					
VAT REGISTRATION NUMBER					
SUPPLIER COMPLIANCE STATUS	TAX COMPLIANCE SYSTEM PIN:		OR	CENTRAL SUPPLIER DATABASE No:	MAAA
ARE YOU THE ACCREDITED REPRESENTATIVE IN SOUTH AFRICA FOR THE GOODS /SERVICES /WORKS OFFERED?	<input type="checkbox"/> Yes <input type="checkbox"/> No [IF YES ENCLOSE PROOF]		ARE YOU A FOREIGN-BASED SUPPLIER FOR THE GOODS /SERVICES /WORKS OFFERED?	<input type="checkbox"/> Yes <input type="checkbox"/> No [IF YES, ANSWER PART B:3]	
QUESTIONNAIRE TO BIDDING FOREIGN SUPPLIERS					
IS THE ENTITY A RESIDENT OF THE REPUBLIC OF SOUTH AFRICA (RSA)?					<input type="checkbox"/> YES <input type="checkbox"/> NO
DOES THE ENTITY HAVE A BRANCH IN THE RSA?					<input type="checkbox"/> YES <input type="checkbox"/> NO
DOES THE ENTITY HAVE A PERMANENT ESTABLISHMENT IN THE RSA?					<input type="checkbox"/> YES <input type="checkbox"/> NO
DOES THE ENTITY HAVE ANY SOURCE OF INCOME IN THE RSA?					<input type="checkbox"/> YES <input type="checkbox"/> NO
IS THE ENTITY LIABLE IN THE RSA FOR ANY FORM OF TAXATION?					<input type="checkbox"/> YES <input type="checkbox"/> NO
IF THE ANSWER IS "NO" TO ALL OF THE ABOVE, THEN IT IS NOT A REQUIREMENT TO REGISTER FOR A TAX COMPLIANCE STATUS SYSTEM PIN CODE FROM THE SOUTH AFRICAN REVENUE SERVICE (SARS) AND IF NOT REGISTERED AS PER 2.3 BELOW.					

Bidder's Initial/Signature: _____

Bid No: NPA 01-25/26	National Prosecuting Authority
Prepared By: Supply Chain Management Unit	
Bid Description: Supply, delivery and installation of Office furniture to the NPA offices for a period of three (3) years.	

PART B

TERMS AND CONDITIONS FOR BIDDING

1. BID SUBMISSION:
1.1. BIDS MUST BE DELIVERED BY THE STIPULATED TIME TO THE CORRECT ADDRESS. LATE BIDS WILL NOT BE ACCEPTED FOR CONSIDERATION.
1.2. ALL BIDS MUST BE SUBMITTED ON THE OFFICIAL FORMS PROVIDED-(NOT TO BE RE-TYPED) OR IN THE MANNER PRESCRIBED IN THE BID DOCUMENT.
1.3. THIS BID IS SUBJECT TO THE PREFERENTIAL PROCUREMENT POLICY FRAMEWORK ACT, 2000 AND THE PREFERENTIAL PROCUREMENT REGULATIONS, 2022, THE GENERAL CONDITIONS OF CONTRACT (GCC) AND, IF APPLICABLE, ANY OTHER SPECIAL CONDITIONS OF CONTRACT.
1.4. THE SUCCESSFUL BIDDER WILL BE REQUIRED TO FILL IN AND SIGN A WRITTEN CONTRACT FORM (SBD7)
2. TAX COMPLIANCE REQUIREMENTS
2.1 BIDDERS MUST ENSURE COMPLIANCE WITH THEIR TAX OBLIGATIONS.
2.2 BIDDERS ARE REQUIRED TO SUBMIT THEIR UNIQUE PERSONAL IDENTIFICATION NUMBER (PIN) ISSUED BY SARS TO ENABLE THE ORGAN OF STATE TO VERIFY THE TAXPAYER'S PROFILE AND TAX STATUS.
2.3 APPLICATION FOR TAX COMPLIANCE STATUS (TCS) PIN MAY BE MADE VIA E-FILING THROUGH THE SARS WEBSITE WWW.SARS.GOV.ZA.
2.4 BIDDERS MAY ALSO SUBMIT A PRINTED TCS CERTIFICATE TOGETHER WITH THE BID.
2.5 IN BIDS WHERE CONSORTIA / JOINT VENTURES / SUB-CONTRACTORS ARE INVOLVED, EACH PARTY MUST SUBMIT A SEPARATE TCS CERTIFICATE / PIN / CSD NUMBER.
2.6 WHERE NO TCS IS AVAILABLE BUT THE BIDDER IS REGISTERED ON THE CENTRAL SUPPLIER DATABASE (CSD), A CSD NUMBER MUST BE PROVIDED.
2.7 NO BIDS WILL BE CONSIDERED FROM PERSONS IN THE SERVICE OF THE STATE, COMPANIES WITH DIRECTORS WHO ARE PERSONS IN THE SERVICE OF THE STATE, OR CLOSE CORPORATIONS WITH MEMBERS PERSONS IN THE SERVICE OF THE STATE."

VALIDITY PERIOD: OFFER TO BE VALID FOR 90 DAYS FROM THE CLOSING DATE OF THE BID.

NB: FAILURE TO PROVIDE / OR COMPLY WITH ANY OF THE ABOVE PARTICULARS MAY RENDER THE BID INVALID.

SIGNATURE OF BIDDER:

CAPACITY UNDER WHICH THIS BID IS SIGNED:
 (Proof of authority must be submitted, e.g., company resolution)

DATE:.....

Bidder's Initial/Signature: _____

SECTION 2**GENERAL CONDITIONS OF CONTRACT****THE GENERAL CONDITIONS OF THE CONTRACT WILL FORM PART OF ALL BID DOCUMENTS AND MAY NOT BE AMENDED**

- 1. Definitions**
1. The following terms shall be interpreted as indicated:
 - 1.1 "Closing time" means the date and hour specified in the bidding documents for the receipt of bids.
 - 1.2 "Contract" means the written agreement entered into between the purchaser and the supplier, as recorded in the contract form signed by the parties, including all attachments and appendices thereto and all documents incorporated by reference therein.
 - 1.3 "Contract price" means the price payable to the supplier under the contract for the full and proper performance of his contractual obligations.
 - 1.4 "Corrupt practice" means the offering, giving, receiving, or soliciting of anything of value to influence the action of a public official in the procurement process or in contract execution.
 - 1.5 "Countervailing duties" are imposed in cases where an enterprise abroad is subsidized by its government and encouraged to market its products internationally.
 - 1.6 "Country of origin" means the place where the goods were mined, grown, or produced or from which the services are supplied. Goods are produced when, through manufacturing, processing or substantial and major assembly of components, a commercially recognized new product results that is substantially different in basic characteristics or in purpose or utility from its components.
 - 1.7 "Day" means calendar day.
 - 1.8 "Delivery" means delivery in compliance with the conditions of the contract or order.
 - 1.9 "Delivery ex stock" means immediate delivery directly from stock actually on hand.
 - 1.10 "Delivery into consignees store or to his site" means delivered and unloaded in the specified store or depot or on the specified site in compliance with the conditions of the contract or order, the supplier bearing all risks and charges involved until the supplies are so delivered and a valid receipt is obtained.
 - 1.11 "Dumping" occurs when a private enterprise abroad market its goods on own initiative in the RSA at lower prices than that of the country of origin and which have the potential to harm the local industries in the RSA.
 - 1.12 "Force majeure" means an event beyond the control of the supplier and not involving the supplier's fault or negligence and not foreseeable. Such events may include, but is not restricted to, acts

Bidder's Initial/Signature: _____

of the purchaser in its sovereign capacity, wars or revolutions, fires, floods, epidemics, quarantine restrictions and freight embargoes.

- 1.13 “Fraudulent practice” means a misrepresentation of facts in order to influence a procurement process or the execution of a contract to the detriment of any bidder, and includes collusive practice among bidders (prior to or after bid submission) designed to establish bid prices at artificial non-competitive levels and to deprive the bidder of the benefits of free and open competition.
- 1.14 “GCC” means the General Conditions of Contract.
- 1.15 “Goods” means all of the equipment, machinery, and/or other materials that the supplier is required to supply to the purchaser under the contract.
- 1.16 “Imported content” means that portion of the bidding price represented by the cost of components, parts or materials which have been or are still to be imported (whether by the supplier or his subcontractors) and which costs are inclusive of the costs abroad, plus freight and other direct importation costs such as landing costs, dock dues, import duty, sales duty or other similar tax or duty at the South African place of entry as well as transportation and handling charges to the factory in the Republic where the supplies covered by the bid will be manufactured.
- 1.17 “Local content” means that portion of the bidding price which is not included in the imported content provided that local manufacture does take place.
- 1.18 “Manufacture” means the production of products in a factory using labour, materials, components, and machinery and includes other related value-adding activities.
- 1.19 “Order” means an official written order issued for the supply of goods or works or the rendering of a service.
- 1.20 “Project site,” where applicable, means the place indicated in the bidding documents.
- 1.21 “Purchaser” means the organization purchasing the goods.
- 1.22 “Republic” means the Republic of South Africa.
- 1.23 “SCC” means the Special Conditions of Contract.
- 1.24 “Services” means those functional services ancillary to the supply of the goods, such as transportation and any other incidental services, such as installation, commissioning, provision of technical assistance, training, catering, gardening, security, maintenance, and other such obligations of the supplier covered under the contract.
- 1.25 “Written” or “in writing” means handwritten in ink or any form of electronic or mechanical writing.

2. Application

- 2.1 These general conditions are applicable to all bids, contracts and orders, including bids for functional and professional services, sales, hiring, letting and the granting or acquiring of rights, but excluding

Bidder's Initial/Signature: _____

- immovable property, unless otherwise indicated in the bidding documents.
- 2.2 Where applicable, special conditions of contract are also laid down to cover specific supplies, services or works
- 2.3 Where such special conditions of contract are in conflict with these general conditions, the special conditions shall apply.
- 3. General**
- 3.1 Unless otherwise indicated in the bidding documents, the purchaser shall not be liable for any expense incurred in the preparation and submission of a bid. Where applicable, a non-refundable fee for documents may be charged.
- 3.2 With certain exceptions, invitations to bid are only published in the Government Tender Bulletin. The Government Tender Bulletin may be obtained directly from the Government Printer, Private Bag X85, Pretoria 0001, or accessed electronically from www.treasury.gov.za
- 4. Standards**
- 4.1 The goods supplied shall conform to the standards mentioned in the bidding documents and specifications.
- 5. Use of contract documents and information; inspection.**
- 5.1 The supplier shall not, without the purchaser's prior written consent, disclose the contract, or any provision thereof, or any specification, plan, drawing, pattern, sample, or information furnished by or on behalf of the purchaser in connection therewith, to any person other than a person employed by the supplier in the performance of the contract. Disclosure to any such employed person shall be made in confidence and shall extend only so far as may be necessary for purposes of such performance.
- 5.2 The supplier shall not, without the purchaser's prior written consent, make use of any document or information mentioned in GCC clause 5.1 except for purposes of performing the contract.
- 5.3 Any document, other than the contract itself mentioned in GCC clause 5.1 shall remain the property of the purchaser and shall be returned (all copies) to the purchaser on completion of the supplier's performance under the contract if so required by the purchaser.
- 5.4 The supplier shall permit the purchaser to inspect the supplier's records relating to the performance of the supplier and to have them audited by auditors appointed by the purchaser, if so required by the purchaser.
- 6. Patent rights**
- 6.1 The supplier shall indemnify the purchaser against all third-party claims of infringement of patent, trademark, or industrial design rights arising from use of the goods or any part thereof by the purchaser.
- 7. Performance security**
- 7.1 Within thirty (30) days of receipt of the notification of contract award, the successful bidder shall furnish to the purchaser the performance security of the amount specified in the SCC.
- 7.2 The proceeds of the performance security shall be payable to the purchaser as compensation for any loss resulting from the supplier's failure to complete his obligations under the contract.
- 7.3 The performance security shall be denominated in the currency of the contract, or in a freely convertible currency acceptable to the purchaser and shall be in one of the following forms:

Bidder's Initial/Signature: _____

- (a) a bank guarantee or an irrevocable letter of credit issued by a reputable bank located in the purchaser's country or abroad, acceptable to the purchaser, in the form provided in the bidding documents or another form acceptable to the purchaser; or
- (b) a cashier's or certified cheque
- 7.4 The performance security will be discharged by the purchaser and returned to the supplier not later than thirty (30) days following the date of completion of the supplier's performance obligations under the contract, including any warranty obligations, unless otherwise specified in the SCC.
- 8. Inspections, tests, and analyses**
- 8.1 All pre-bidding testing will be for the account of the bidder.
- 8.2 If it is a bid condition that supplies to be produced or services to be rendered should at any stage during production or execution or on completion be subject to inspection, the premises of the bidder or contractor shall be open, at all reasonable hours, for inspection by a representative of the Department or an organization acting on behalf of the Department.
- 8.3 If there are no inspection requirements indicated in the bidding documents and no mention is made in the contract, but during the contract period it is decided that inspections shall be carried out, the purchaser shall itself make the necessary arrangements, including payment arrangements with the testing authority concerned.
- 8.4 If the inspections, tests, and analyses referred to in clauses 8.2 and 8.3 show the supplies to be in accordance with the contract requirements, the cost of the inspections, tests and analyses shall be defrayed by the purchaser.
- 8.5 Where the supplies or services referred to in clauses 8.2 and 8.3 do not comply with the contract requirements, irrespective of whether such supplies or services are accepted or not, the cost in connection with these inspections, tests or analyses shall be defrayed by the supplier.
- 8.6 Supplies and services which are referred to in clauses 8.2 and 8.3 and which do not comply with the contract requirements may be rejected.
- 8.7 Any contract supplies may on or after delivery be inspected, tested or analyzed and may be rejected if found not to comply with the requirements of the contract. Such rejected supplies shall be held at the cost and risk of the supplier who shall, when called upon, remove them immediately at his own cost and forthwith substitute them with supplies which do comply with the requirements of the contract. Failing such removal, the rejected supplies shall be returned at the suppliers cost and risk. Should the supplier fail to provide the substitute supplies forthwith, the purchaser may, without giving the supplier further opportunity to substitute the rejected supplies, purchase such supplies as may be necessary at the expense of the supplier.
- 8.8 The provisions of clauses 8.4 to 8.7 shall not prejudice the right of the purchaser to cancel the contract on account of a breach of the conditions thereof, or to act in terms of Clause 23 of GCC.

Bidder's Initial/Signature: _____

- 9. Packing**
- The supplier shall provide such packaging of the goods as is required to prevent their damage or deterioration during transit to their final destination, as indicated in the contract. The packing shall be sufficient to withstand, without limitation, rough handling during transit and exposure to extreme temperatures, salt and precipitation during transit, and open storage. Packing, case size and weights shall take into consideration, where appropriate, the remoteness of the goods' final destination and the absence of heavy handling facilities at all points in transit.
- The packing, marking, and documentation within and outside the packages shall comply strictly with such special requirements as shall be expressly provided for in the contract, including additional requirements, if any, specified in SCC, and in any subsequent instructions ordered by the purchaser.
- 10. Delivery and documents**
- 10.1 Delivery of the goods shall be made by the supplier in accordance with the terms specified in the contract. The details of shipping and/or other documents to be furnished by the supplier are specified in SCC.
- 10.2 Documents to be submitted by the supplier are specified in SCC.
- 11. Insurance**
- 11.1 The goods supplied under the contract shall be fully insured in a freely convertible currency against loss or damage incidental to manufacture or acquisition, transportation, storage, and delivery in the manner specified in the SCC.
- 12. Transportation**
- 12.1 Should a price other than an all-inclusive delivered price be required, this shall be specified in the SCC.
- 13. Incidental services**
- 13.1 The supplier may be required to provide any or all of the following services, including additional services, if any, specified in SCC:
- (a) performance or supervision of on-site assembly and/or commissioning of the supplied goods;
 - (b) furnishing of tools required for assembly and/or maintenance of the supplied goods;
 - (c) furnishing of a detailed operations and maintenance manual for each appropriate unit of the supplied goods;
 - (d) performance or supervision or maintenance and/or repair of the supplied goods, for a period of time agreed by the parties, provided that this service shall not relieve the supplier of any warranty obligations under this contract; and
 - (e) training of the purchaser's personnel, at the supplier's plant and/or on-site, in assembly, start-up, operation, maintenance, and/or repair of the supplied goods.
- 13.2 Prices charged by the supplier for incidental services, if not included in the contract price for the goods, shall be agreed upon in advance by the parties and shall not exceed the prevailing rates charged to other parties by the supplier for similar services.
- 14. Spare parts**
- 14.1 As specified in the SCC, the supplier may be required to provide any or all of the following materials, notifications, and information pertaining to spare parts manufactured or distributed by the supplier:

Bidder's Initial/Signature: _____

- (a) such spare parts as the purchaser may elect to purchase from the supplier, provided that this election shall not relieve the supplier of any warranty obligations under the contract; and
- (b) In the event of termination of production of the spare parts:
 - (i) Advance notification to the purchaser of the pending termination, in sufficient time to permit the purchaser to procure needed requirements; and
 - (ii) following such termination, furnishing at no cost to the purchaser, the blueprints, drawings, and specifications of the spare parts, if requested.

15. Warranty

- 15.1 The supplier warrants that the goods supplied under the contract are new, unused, of the most recent or current models, and that they incorporate all recent improvements in design and materials unless provided otherwise in the contract. The supplier further warrants that all goods supplied under this contract shall have no defect, arising from design, materials, or workmanship (except when the design and/or material is required by the purchaser's specifications) or from any act or omission of the supplier, that may develop under normal use of the supplied goods in the conditions prevailing in the country of final destination.
- 15.2 This warranty shall remain valid for twelve (12) months after the goods, or any portion thereof as the case may be, have been delivered to and accepted at the final destination indicated in the contract, or for eighteen (18) months after the date of shipment from the port or place of loading in the source country, whichever period concludes earlier, unless specified otherwise in SCC.
- 15.3 The purchaser shall promptly notify the supplier in writing of any claims arising under this warranty.
- 15.4 Upon receipt of such notice, the supplier shall, within the period specified in SCC and with all reasonable speed, repair or replace the defective goods or parts thereof, without costs to the purchaser.
- 15.5 If the supplier, having been notified, fails to remedy the defect(s) within the period specified in SCC, the purchaser may proceed to take such remedial action as may be necessary, at the supplier's risk and expense and without prejudice to any other rights which the purchaser may have against the supplier under the contract.

16. Payment

- 16.1 The method and conditions of payment to be made to the supplier under this contract shall be specified in SCC.
- 16.2 The supplier shall furnish the purchaser with an invoice accompanied by a copy of the delivery note and upon fulfilment of other obligations stipulated in the contract.
- 16.3 Payments shall be made promptly by the purchaser, but in no case later than thirty (30) days after submission of an invoice or claim by the supplier.
- 16.4 Payment will be made in Rand unless otherwise stipulated in SCC.

17. Prices

- 17.1 Prices charged by the supplier for goods delivered and services performed under the contract shall not vary from the prices quoted by the supplier in his bid, with the exception of any price adjustments

Bidder's Initial/Signature: _____

- authorized in SCC or in the purchaser's request for bid validity extension, as the case may be.
- 18. Contract amendments** 18.1 No variation in or modification of the terms of the contract shall be made except by written amendment signed by the parties concerned.
- 19. Assignment** 19.1 The supplier shall not assign, in whole or in part, its obligations to perform under the contract.
- 20. Subcontracts** 20.1 The supplier shall notify the purchaser in writing of all subcontracts awarded under this contract if not already specified in the bid. Such notification, in the original bid or later, shall not relieve the supplier from any liability or obligation under the contract
- 21. Delays in the supplier's performance** 21.1 Delivery of the goods and performance of services shall be made by the supplier in accordance with the time schedule prescribed by the purchaser in the contract.
- 21.2 If at any time during performance of the contract, the supplier or its subcontractor(s) should encounter conditions impeding timely delivery of the goods and performance of services, the supplier shall promptly notify the purchaser in writing of the fact of the delay, its likely duration, and its cause(s). As soon as practicable after receipt of the supplier's notice, the purchaser shall evaluate the situation and may at his discretion extend the supplier's time for performance, with or without the imposition of penalties, in which case the extension shall be ratified by the parties by amendment of the contract.
- 21.3 No provision in a contract shall be deemed to prohibit the obtaining of supplies or services from a national department, provincial department, or a local authority.
- 21.4 The right is reserved to procure outside of the contract small quantities or to have minor essential services executed if an emergency arises, the supplier's point of supply is not situated at or near the place where the supplies are required, or the supplier's services are not readily available.
- 21.5 Except as provided under GCC Clause 25, a delay by the supplier in the performance of its delivery obligations shall render the supplier liable to the imposition of penalties, pursuant to GCC Clause 22, unless an extension of time is agreed upon pursuant to GCC Clause 21.2 without the application of penalties.
- 21.6 Upon any delay beyond the delivery period in the case of a supplies contract, the purchaser shall, without cancelling the contract, be entitled to purchase supplies of a similar quality and up to the same quantity in substitution of the goods not supplied in conformity with the contract and to return any goods delivered later at the supplier's expense and risk, or to cancel the contract and buy such goods as may be required to complete the contract and without prejudice to his other rights, be entitled to claim damages from the supplier.

Bidder's Initial/Signature: _____

- 22. Penalties**
- 22.1 Subject to GCC Clause 25, if the supplier fails to deliver any or all of the goods or to perform the services within the period(s) specified in the contract, the purchaser shall, without prejudice to its other remedies under the contract, deduct from the contract price, as a penalty, a sum calculated on the delivered price of the delayed goods or unperformed services using the current prime interest rate calculated for each day of the delay until actual delivery or performance. The purchaser may also consider termination of the contract pursuant to GCC Clause 23.
- 23. Termination for default**
- 23.1 The purchaser, without prejudice to any other remedy for breach of contract, by written notice of default sent to the supplier, may terminate this contract in whole or in part:
- (a) If the supplier fails to deliver any or all of the goods within the period(s) specified in the contract, or within any extension thereof granted by the purchaser pursuant to GCC Clause 21.2.
 - (b) if the Supplier fails to perform any other obligation(s) under the contract; or
 - (c) if the supplier, in the judgment of the purchaser, has engaged in corrupt or fraudulent practices in competing for or in executing the contract.
- 23.2 In the event the purchaser terminates the contract in whole or in part, the purchaser may procure, upon such terms and in such manner as it deems appropriate, goods, works or services similar to those undelivered, and the supplier shall be liable to the purchaser for any excess costs for such similar goods, works or services. However, the supplier shall continue performance of the contract to the extent not terminated.
- 23.3 Where the purchaser terminates the contract in whole or in part, the purchaser may decide to impose a restriction penalty on the supplier by prohibiting such supplier from doing business with the public sector for a period not exceeding 10 years.
- 23.4 If a purchaser intends imposing a restriction on a supplier or any person associated with the supplier, the supplier will be allowed a time period of not more than fourteen (14) days to provide reasons why the envisaged restriction should not be imposed. Should the supplier fail to respond within the stipulated fourteen (14) days, the purchaser may regard the intended penalty as not objected against and may impose it on the supplier.
- 23.5 Any restriction imposed on any person by the Accounting Officer/Authority will, at the discretion of the Accounting Officer/Authority, also be applicable to any other enterprise or any partner, manager, director or other person who wholly or partly exercises or exercised or may exercise control over the enterprise of the first-mentioned person, and with which control over the first-mentioned person, and with which enterprise or person the first-mentioned person, is or was in the opinion of the Accounting Officer/Authority actively associated.
- 23.6 If a restriction is imposed, the purchaser must, within five (5) working days of such imposition, furnish the National Treasury, with the following information:

Bidder's Initial/Signature: _____

- (i) the name and address of the supplier and/or person restricted by the purchaser.
- (ii) the date of commencement of the restriction
- (iii) the period of restriction; and
- (iv) the reasons for the restriction

These details will be loaded in the National Treasury's central database of suppliers or persons prohibited from doing business with the public sector.

23.7 If a court of law convicts a person of an office as contemplated in sections 12 and 13 of the Prevention and Combating of Corrupt Activities Act, No 12 of 2004, the court may also rule that such person's name be endorsed on the Register for Tender Defaulters. When a person's name has been endorsed on the Register, the person will be prohibited from doing business with the public sector for a period not less than five years and not more than 10 years. The National Treasury is empowered to determine the period of restriction, and each case will be dealt with on its own merits. According to section 32 of the Act, the Register must be open to the public. The Register can be perused on the National Treasury website.

24. Anti-dumping and countervailing duties and rights

24.1 When, after the date of bid, provisional payments are required, or anti-dumping or countervailing duties are imposed, or the amount of a provisional payment or anti-dumping or countervailing right is increased in respect of any dumped or subsidized import, the State is not liable for any amount so required or imposed, or for the amount of any such increase. When, after the said date, such a provisional payment is no longer required or any such anti-dumping or countervailing right is abolished, or where the amount of such provisional payment or any such right is reduced, any such favorable difference shall on demand be paid forthwith by the contractor to the State or the State may deduct such amounts from moneys (if any) which may otherwise be due to the contractor in regard to supplies or services which he delivered or rendered, or is to deliver or render in terms of the contract or any other contract or any other amount which may be due to him

25. Force Majeure

25.1 Notwithstanding the provisions of GCC Clauses 22 and 23, the supplier shall not be liable for forfeiture of its performance security, damages, or termination for default if and to the extent that his delay in performance or other failure to perform his obligations under the contract is the result of an event of force majeure.

25.2 If a force majeure situation arises, the supplier shall promptly notify the purchaser in writing of such conditions and the cause thereof. Unless otherwise directed by the purchaser in writing, the supplier shall continue to perform its obligations under the contract as far as is reasonably practical and shall seek all reasonable alternative means for performance not prevented by the force majeure event.

26. Termination for insolvency

26.1 The purchaser may at any time terminate the contract by giving written notice to the supplier if the supplier becomes bankrupt or otherwise insolvent. In this event, termination will be without compensation to the supplier, provided that such termination will not prejudice or affect any right of action or remedy which has accrued or will accrue thereafter to the purchaser.

Bidder's Initial/Signature: _____

- | | | |
|------------------------------------|------|---|
| 27. Settlement of Disputes | 27.1 | If any dispute or difference of any kind whatsoever arises between the purchaser and the supplier in connection with or arising out of the contract, the parties shall make every effort to resolve amicably such dispute or difference by mutual consultation. |
| | 27.2 | If, after thirty (30) days, the parties have failed to resolve their dispute or difference by such mutual consultation, then either the purchaser or the supplier may give notice to the other party of their intention to commence with mediation. No mediation in respect of this matter may be commenced unless such notice is given to the other party. |
| | 27.3 | Should it not be possible to settle a dispute by means of mediation, it may be settled in a South African court of law. |
| | 27.4 | Mediation proceedings shall be conducted in accordance with the rules of procedure specified in the SCC. |
| | 27.5 | Notwithstanding any reference to mediation and/or court proceedings herein,
(a) the parties shall continue to perform their respective obligations under the contract unless they otherwise agree; and

(b) The purchaser shall pay the supplier any monies due the supplier. |
| 28. Limitation of liability | 28.1 | Except in cases of criminal negligence or wilful misconduct, and in the case of infringement pursuant to Clause 6;

(a) The supplier shall not be liable to the purchaser, whether in contract, tort, or otherwise, for any indirect or consequential loss or damage, loss of use, loss of production, or loss of profits or interest costs, provided that this exclusion shall not apply to any obligation of the supplier to pay penalties and/or damages to the purchaser; an

(b) The aggregate liability of the supplier to the purchaser, whether under the contract, in tort or otherwise, shall not exceed the total contract price, provided that this limitation shall not apply to the cost of repairing or replacing defective equipment. |
| 29. Governing language | 29.1 | The contract shall be written in English. All correspondence and other documents pertaining to the contract that is exchanged by the parties shall also be written in English. |
| 30. Applicable law | 30.1 | The contract shall be interpreted in accordance with South African laws, unless otherwise specified in SCC. |
| 31. Notices | 31.1 | Every written acceptance of a bid shall be posted to the supplier concerned by registered or certified mail and any other notice to him shall be posted by ordinary mail to the address furnished in his bid or to the address notified later by him in writing and such posting shall be deemed to be proper service of such notice |
| | 31.2 | The time mentioned in the contract documents for performing any act after such aforesaid notice has been given, shall be reckoned from the date of posting of such notice. |

Bidder's Initial/Signature: _____

- | | | |
|---|------|---|
| 32. Taxes and duties | 32.1 | A foreign supplier shall be entirely responsible for all taxes, stamp duties, license fees, and other such levies imposed outside the purchaser's country. |
| | 32.2 | A local supplier shall be entirely responsible for all taxes, duties, license fees, etc., incurred until delivery of the contracted goods to the purchaser. |
| | 32.3 | No contract shall be concluded with any bidder whose tax matters are not in order. Prior to the award of a bid the Department must be in possession of a tax clearance certificate, submitted by the bidder. This certificate must be an original issued by the South African Revenue Services. |
| 33. National Industrial Participation Program (NIPP) | 33.1 | The NIPP program administered by the Department of Trade and Industry shall be applicable to all contracts that are subject to the NIP obligation. |
| 34. Prohibition of Restrictive Practices | 34.1 | In terms of section 4 (1) (b) (iii) of the Competition Act No.89 of 1998, as amended, an agreement between, or concerted practice by, firms, or a decision by an association of firms, is prohibited if it is between parties in a horizontal relationship and if a bidder (s) is /are or a contractor(s) was/ were involved in collusive bidding (or bid rigging). |
| | 34.2 | If a bidder(s) or contractor(s), based on reasonable grounds or evidence obtained by the purchaser, has/ have engaged in the restrictive practice referred to above, the purchaser may refer the matter to the Competition Commission for investigation and possible imposition of administrative penalties as contemplated in the Competition Act No.89 of 1998. |
| | 34.3 | If a bidder(s) or contractor(s), has /have been found guilty by the Competition Commission of the restrictive practice referred to above, the purchaser may, in addition and without prejudice to any other remedy provided for, invalidate the bid(s) for such item(s) offered, and or terminate the contract in whole or part, and/or restrict the bidder (s) or contractor(s) from conducting business with the public sector for a period not exceeding ten (10) years and/or claim damages from the bidder(s) or contractor concerned. |

Bidder's Initial/Signature: _____

SECTION 3**SPECIAL CONDITIONS OF THE BID**

1. Bids submitted must be in line with the detailed specification. **Failure to bid accordingly will result in the disqualification of the bids.**
2. Bidders' attention is drawn to the fact that amendments to any of the Special Conditions will result in their bids being disqualified.
3. The NPA may, at any time or times before the bid submission date, issue to the bidders any amendment, annexure, or addendum to the bid documents. No amendment, annexure or addendum will form part of the bid documents unless it is in writing and expressly stated that it shall form part of the bid document.
4. The NPA reserves the right;
 - 4.1 Not to appoint and/or cancel the bid at any time and shall not be bound to accept the lowest bid or proposal.
 - 4.2 To award a bid to one or more service providers.
 - 4.3 To award the bid as a whole or in part.
 - 4.4 To enter into negotiation with one or more bidders regarding any terms and conditions, including price(s), of a proposed contract before or after the conclusion of the contract. (BAFO "Best and Final Offer")
 - 4.5 To terminate any contract where service has not been carried out to its satisfaction.
 - 4.6 To amend any bid condition, validity period, or extend the closing date of bids.
 - 4.7 To cancel and/or terminate the bid process at any stage, including after the closing date and/or after presentations have been made, and/or after bids have been evaluated and/or after shortlisted bidders have been notified of their status.
 - 4.8 To conduct site inspections and or due diligence, or explanatory meetings to verify the nature and quality of services offered by the bidder. This will be done before/or after adjudication of the bid. The site inspection and or due diligence will be conducted with shortlisted bidders only.
 - 4.9 To reject office furniture that does not comply with the minimum specifications and for these to be replaced at the bidder's cost.
 - 4.10 To purchase standard items outside this contract, should the successful bidder fail to deliver on time as agreed by both parties, and if so, similar products could be purchased at a negotiated price that is less than the stated contract price.
 - 4.11 To liaise with the awarded bidder, whereby there are design implications, i.e., variances or modifications have been identified due to the type, finishes, size or dimensions of the office furniture. Such information will be communicated to the successful bidder. Both parties will agree prior to the manufacturing, supply, delivery, and installation of furniture.
5. As per National Treasury Instruction note no 9 of 2017/18, bidders are required to register their companies on the government Central Supplier Database (CSD) and include in their bid a copy of their Master Registration Number (Supplier Number).
6. Bidders are required to provide a tax compliance status PIN or the Central Supplier Database Master Registration Number (MAAA Number) to enable the NPA to view their tax profile and verify the bidder's tax compliance status.
7. Foreign suppliers with neither a South African tax obligation nor history of doing business in South Africa must complete a pre-award questionnaire on the Standard Bidding Document 1 for their tax obligation categorisation.

Bidder's Initial/Signature: _____

8. Preferential consideration will be given to bidders that are legal entities. In the case of Subcontracting, the NPA will enter into a single contract with a principal service provider.
9. Bidders must submit documentary proof of the existence of joint ventures and/or consortium arrangements. The NPA will accept signed agreements as acceptable proof of the existence of a joint venture and/or consortium arrangement. The joint venture and/or consortium agreements must clearly set out the roles and responsibilities of the Lead Partner and joint venture and/or consortium party. The agreement must also identify the Lead Partner, with the power of attorney to bind the other party/parties in respect of matters pertaining to the joint venture and/or consortium arrangement.
10. The NPA may request written clarification or further information regarding any aspect of this bid. The bidders must supply the requested information in writing within two (2) working days after the request has been made, otherwise the proposal may be disqualified.
11. Storage of office furniture: NPA **WILL NOT** provide storage for the successful bidders' office furniture. Therefore, furniture **MUST** be assembled and installed upon delivery on site.
12. Format of Invoices - Invoices must indicate the item description, the quantity of items delivered; the VAT excluded price per item as well as the VAT inclusive price per item. Note that the desk legs, brackets and snake management system must form part of the main component and cost of each desk to be delivered.
13. Prices are to be fixed and prices tendered are to be net of all discounts. All transport and insurance costs must be included in the total bid price. Goods in transit are solely the responsibility of the service provider.
14. Bidders to submit a signed letter of intent from the manufacturer (in case you are not a manufacturer). If the bidder is a manufacturer, this must be indicated in a signed letter.
15. The quantities indicated in the pricing schedule are for **planning purposes only**. No guarantees can be given on the actual quantities required because purchase orders will be placed/ made when the need arises.
16. The successful bidder is expected to repair office furniture within **fourteen (14) days** and failure to repair; the successful bidder must replace the office furniture within **ten (10) days**.
17. The NPA will enter into a Service Level Agreement with the successful bidder, effective from the date of bid award, taking all aspects of the contract into account.
18. Under no circumstances will negotiation with any bidders constitute an award or promise / undertaking to award the contract.
19. The successful service provider will be subjected to a security screening process by the NPA. If the results thereof are negative and/or unfavourable and/or have a material or adverse effect to the carrying out of this contract, NPA shall be entitled to cancel this contract immediately, in writing.
20. The employees of the successful service provider may be subject to screening for security purposes by the NPA at least once in the contract period or as and when other surrounding circumstances so requires. Any such employees whose security screening comes back negative, shall be removed from the NPA's site by the service provider immediately upon request by the NPA.

Bidder's Initial/Signature: _____

21. CONFLICT OF INTEREST, CORRUPTION AND FRAUD

21.1 The NPA reserves its right to disqualify any bidder who with or without their company / business, whether in respect of the NPA or any other government organ or entity and whether from the Republic of South Africa or otherwise ("Government Entity"), –

21.1.1 Engages in any collusive tendering, anti-competitive conduct, or any other similar conduct, including but not limited to any collusion with any other Bidder or company / business in respect of the subject matter of this bid;

21.1.2 Seeks any assistance, other than assistance officially provided by a Government Entity, from any employee, advisor or other representative of a Government Entity in order to obtain any unlawful advantage in relation to procurement or services provided or to be provided to a Government Entity;

21.1.3 Makes or offers any gift, gratuity, anything of value or other inducement, whether lawful or unlawful, to any of the NPA's officers, directors, employees, advisors, or other representatives;

21.1.4 Accepts anything of value or an inducement that would or may provide financial gain, advantage, or benefit in relation to procurement or services provided or to be provided to a Government Entity;

21.1.5 Pays or agrees to pay to any person any fee, commission, percentage, brokerage fee, gift, or any other consideration, that is contingent upon or results from the award of any tender, contract, right or entitlement which is in any way related to procurement or the rendering of any services to a Government Entity.

21.1.6 Has in the past engaged in any matter referred to above.

22. INDEMNITY

If a Bidder breaches the conditions of this bid and, as a result of that breach, the NPA incurs costs or damages (including, without limitation, the cost of any investigations, procedural impairment, repetition of all or part of the bid process or enforcement of intellectual property rights / confidentiality obligations), then the Bidder indemnifies and holds the NPA harmless from any and all such costs which the NPA may incur and for any damages or losses the NPA may suffer.

23. PRECEDENCE

This document will prevail over any information provided during any briefing session whether oral or written, unless such written information provided, expressly amends this document by reference.

24. TAX COMPLIANCE

No award shall be made to a Bidder whose tax affairs are not in order. The NPA reserves the right to withdraw an award made to a service provider in the event that it is established that such service provider does not remain tax compliant for the full term of the contract.

25. GOVERNING LAW

South African law governs this bid and the bid response process. The Bidder agrees to submit to the exclusive jurisdiction of the South African courts in any dispute of any kind that may arise out of or in connection with the subject matter of this bid, the bid itself and all processes associated with the bid.

26. RESPONSIBILITY FOR COMPANY/BUSINESS PERSONNEL

26.1 A bidder is responsible for ensuring that its personnel (including agents, officers, directors, employees, advisors, and other representatives), comply with all terms and conditions of the bid.

Bidder's Initial/Signature: _____

- 26.2 Bidding companies must clearly indicate if they envisage sub-contracting part of the project. The specific goals of the company to which work will be sub-contracted must also be clearly indicated as per table 1 on page 34 of 43 of SBD 6.1.
- 26.3 The bidder must have the infrastructure (physical premises) and the capacity to supply and/or deliver items/service required.
- 26.4 Bidders are required to quote per line item and show a complete price breakdown where necessary/applicable. Failure to do so may result in disqualification of the bid.
- 26.5 At the discretion of NPA, shortlisted bidders may be required to provide the NPA with a mock-up furniture samples available for inspections **TWO (2) WEEKS** after notification at their own premises.
- 26.6 The bidder must include all cost of protective packaging for all items, as well as delivery cost, as NPA will not accept damaged goods due to sub-standard packaging and delivery.
- 26.7 Should a new design be implemented; a bidder may be expected to supply the NPA with manufacturing specifications and/or drawings templates of such furniture during spatial planning. The format of these to be on readable format for example **PDF**. Draft templates of these drawings/specifications must be approved by the NPA before issuing.
- 26.8 Newly acquired office furniture will be bar-coded by the NPA upon delivery. All items supplied should have the following details affixed, out of sight, in the form of a plasticized sticker: **SUPPLIER NAME, PHYSICAL ADDRESS & CONTACT DETAILS.**
- 26.9 The quality of furniture must be guaranteed against faulty workmanship and material excluding normal wear and tear or malicious damage. The bidder will be responsible for all manufacturing defects and delivery of damaged furniture.
- 26.10 **Damages to NPA property:** In the case of damages to floor, walls, furniture, etc. resulting from assembly and installation of office furniture, the successful bidder undertakes to rectify/repair the damage immediately after notification by the project manager. Should the successful bidder fail to act after notification, the NPA will rectify damages and costs will be recovered from the successful bidder.
- 26.11 **Access to the building:** The successful bidder shall have access to the building in terms of its contract during normal office hours.
- 26.12 The service provider must supply and/or deliver the items as specified on the official signed NPA purchase order within the agreed time by both parties after receipt of purchase order.
- 26.13 The NPA shall not accept any responsibilities of any expenses incurred by the bidder that was not part of contract and/or liable for any expenses incurred during the bidding process.
- 26.14 **Delivery lead times** – successful bidder is expected to supply, deliver, and install office furniture and equipment within 4 weeks after receipt of an official order.
- 26.15 The NPA requires that the labour workmanship should be guaranteed for at least three (3) or more years after the installation of office furniture.
- 26.16 The specifications in the bid are minimum requirements. The NPA accepts no responsibility for designs defects in these specifications and expects the bidder to indicate possible defects and supply a workable alternative solution for the NPA approval.

Bidder's Initial/Signature: _____

- 26.17 The NPA expects continuity of quality as laid down in the minimum specification for the duration of the contract.
- 26.18 The successful bidder is expected to repair office furniture within the warranty period and reasonable timeframes agreed by both parties. In the case where furniture is irreparable, the service provider must replace furniture according to the NPA furniture specifications standard at no additional cost.
- 26.19 Bidders are requested to endorse their signature/initial on every page of the bid document and were including where signatures of witnesses are required.
- 26.20 NPA reserves the right to review the contract on an annual basis, which may include the addition or removal of items, adjustments in sizes, and the inclusion of specific furniture (Ergonomic chair) requests that fall outside the established norms and standards.

27. **BID PROPOSAL SHOULD INCLUDE BUT NOT LIMITED TO THE FOLLOWING IN DETAIL:**

27.1 **Bidder's profile** – summary and description of the key features of the bidder. The legal name of the entity, the principal business, with a description of the corporate organization of the proposing entity, including all members of the sub-contract, if any.

27.2 **Proposed Methodology**

27.2.1 Bidders should provide a detailed approach and methodology regarding the manufacturing, supply, delivery, and installation of the office furniture based on the specifications. A project execution/implementation plan detailing project activities or tasks, timelines and deliverables schedule including the following information:

- Project activities, timelines and deliverables that covers the project execution phases i.e., from production and manufacturing, ordering process, supply and delivery including installation of furniture (work break down structure).
- Indicate capacity/resources in undertaking the project. Inclusive of human resources with experience to effectively fulfill service requirements of this nature and size.
- Correction of incorrect/damaged items within ten (10) working days.

27.3 **Track record and experience in supply, delivery, and installation of office furniture.**

27.3.1 Bidders must provide information that demonstrates specific and/or adequate proof of experience and track record in supply, delivery, and installation of office furniture. Such claims must be supported with signed reference letter(s) to permit the NPA to verify the claimed capabilities. To support all claims of experience presented and to assist the NPA in reviewing and evaluation of the proposals, bidders are requested to provide the following:

- One (1) or more reference letters on the client's letterhead, signed by relevant authority where similar projects of supplying, delivery and installation of office furniture were executed. The reference letters must enlist the following information: entity name, contact details, value of the contract and quantities, nature of service rendered indicating client's satisfaction with bidder's delivery of service and contract period (start and end date). **The focus of the reference letter should address the relevant work experience in office furniture/ manufacturing. Purchase order, award letter/s and appointment letter/s will not be considered**

Bidder's Initial/Signature: _____

SECTION 4**BID SUBMISSION REQUIREMENTS****1. WHO MAY SUBMIT A RESPONSE TO THIS BID?**

- 1.1 The NPA invites bids from bidders who comply with the requirements for this bid. In view of the scope of work required in this bid, the NPA has decided that the bidder must:
- Be able to deliver the scope and breadth of services as required.
 - Comply with all other requirements as stipulated in the bid document.

2. FRAUD AND CORRUPTION

- 2.1 All service providers are to take note of the implications of contravening the Prevention and Combating of Corrupt Activities Act, Act No 12 of 2004 and any other Act applicable.

3. CLARIFICATION / QUERIES

- 3.1 Telephonic requests for clarification will not be considered. Any clarification required by a bidder regarding the meaning or interpretation of the Terms of Reference/specifications, or any other aspect concerning the bid or bid document, is to be requested in writing (e-mail) from the following contact person, stating the bid reference number:

Bid Enquiries : Kabelo Maree
E-mail : tenders@npa.gov.za

- 3.2 Queries received will be responded to within two (2) working days of receiving the query.
- 3.3 The NPA will not respond to any enquiries received less than seventy-two (72) hours before the closing date and time of the bid.
- 3.4 Bidders will get a copy of the bid document at the reception, **VGM Building (Corner Westlake & Hartley) 123 Westlake Avenue, Weavind Park, Silverton, Pretoria**, and the soft copy will be available on the **NPA website (www.npa.gov.za)** and National Treasury E-portal.

4. SUBMITTING BIDS

- 4.1 One (1) original and two (2) copies of the bid proposals must be handed in / delivered to the address indicated below:

PHYSICAL ADDRESS	POSTAL ADDRESS
NATIONAL PROSECUTING AUTHORITY VGM BUILDING WEAVIND PARK 123 WEST LAKE AVENUE SILVERTON PRETORIA	NATIONAL PROSECUTING AUTHORITY THE BID OFFICE PRIVATE BAG X 752 PRETORIA 0001

- 4.2 It is the responsibility of the bidder to ensure that bid documents reach the NPA on or before the closing date and time of the bid on the addresses as outlined in paragraph 4.1 above. The NPA will NOT take responsibility for any bid documents received late.

NB: Bidders must indicate on the cover page of each document whether it is an original or a copy.

- 4.3 Should there be any bona fide discrepancy between the original document and the copy the original will be regarded as the valid document. Malicious discrepancies may result in the disqualification of the bidder.

Bidder's Initial/Signature: _____

- 4.4 All paper copies must be neatly bound. All additions to the bid document i.e., Appendices, supporting documentation, pamphlets, photographs, technical specifications, and other support documentation covering the equipment offered etc. shall be neatly bound as part of the schedule concerned.
- 4.5 The NPA will not accept responsibility for any documentation, which gets lost.
- 4.6 An original version of the bid must be submitted. An authorized employee must sign the original version in ink, or representative of the bidder and each page of the proposal shall contain the initial of the same signatory/ies.
- 4.7 **Bulky documents:** Bidders are requested to make an arrangement prior to submitting the bulky documents. The NPA will not take responsibility for the bid documents left anywhere else other than the tender box as indicated in paragraph 4.1 above. Bidders are encouraged to call 012 6487/6077 or to email tenders@npa.gov.za to make arrangements two days before the closing date of the bid.

5. MARKING ON BID ENVELOPE / PACK

- 5.1 Bids must be submitted in a sealed envelope, or sealed pack if too big for an envelope, marked as follows:
- Attention : Tender Box:
 - : Supply Chain Management
 - Bid number : NPA 01 25/26
 - Closing date and time : 01 December 2025 @ 11h00
 - The name and address of the bidder

- 5.2 It is the responsibility of the bidder to ensure that bid documents reach the NPA on or before the closing date of the bid at the addresses as outlined on paragraph 5.1 above. The NPA will NOT take responsibility for any bid documents received late.

- 5.3 Documents submitted on time by bidders shall not be returned.

6. LATE BIDS

- 6.1 Bids received late shall not be considered. A bid will be considered late if it arrived even one second after 11:00am or any time thereafter. The tender (bid) box shall be locked at exactly 11:00am and bids arriving late will not be considered under any circumstances, such as traffic problems, getting lost etc. Bidders are therefore strongly advised to ensure that bids are dispatched, allowing enough time for any unforeseen events that may delay the delivery of a bid.
- 6.2 Bidders are therefore strongly advised to ensure that bids are dispatched, allowing enough time for any unforeseen events that may delay the delivery of the bid.
- 6.3 The official Telkom time (Dial 1026) will be used to verify the exact closing time.

7. DIRECTIONS TO THE NPA OFFICES FOR DELIVERY OF BIDS

From Pretoria City Centre

Take the Pretoria Road (extension of Church Street East) leading to Silverton. Turn left (north) into Creswell Street opposite the Botanical Gardens. Proceed until you get to the second street and turn left into Hartley Street. Continue straight ahead; this will take you to the main entrance of the VGM building.

Bidder's Initial/Signature: _____

N1 from North

Take the Stormvoël turn-off. Turn left at the traffic light. At the next robot turn right into the street leading to Koedoespoort. Proceed through Koedoespoort over the 3-way stop. At the next street, turn right into Hartley Street, which will lead you to the main entrance of the VGM Building.

N1 from the South (coming from Johannesburg)

Take the Polokwane/Krugersdorp turn-off and follow the Polokwane N1 leading to the North. Proceed past Centurion and skip the following turn-offs: Botha Avenue, Alberton (old Jan Smuts), Rigel Avenue and Atterbury Road.

Take the Lynnwood Road turn-off, turn right into Lynnwood Road, over the highway, and immediately left into Meiring Naude (direction CSIR). Pass the CSIR until you get to a T-junction with Cussonia Street. Turn left, keeping to the right side of the road. Take the curve right in front of the CBC School. At the second robot turn left into Creswell Road, and at the second street thereafter turn left into Hartley Street. This will take you to the main entrance of the VGM Building. Bidders should allow time to access the premises due to security arrangements that need to be observed.

8. ACCESS TO INFORMATION

- 8.1 All bidders will be informed of the status of their bid once the bid process has been completed.
- 8.2 Requests for information regarding the bid process will be dealt with in line with the NPA SCM Policy and relevant legislation.

9. REASONS FOR REJECTION

- 9.1 NPA shall reject a proposal for the award of a contract if the recommended bidder has committed a proven corrupt or fraudulent act in competing for the particular contract.
- 9.2 NPA may disregard the bid of any bidder if that bidder, or any of its directors:
 - 9.2.1 Have abused the SCM system of NPA.
 - 9.2.2 Have committed proven fraud or any other improper conduct in relation to such system.
 - 9.2.3 Have failed to perform on any previous contract, and the proof exists; such actions shall be communicated to the National Treasury.
- 9.3 Bidders that submit incomplete information and documentation not according to the requirements of the terms of reference and special conditions.
- 9.4 Bidders that fail to submit a bid proposal.
- 9.5 Bidders who receive information not available to other vendors through fraudulent means.

10. CANCELLATION OF BID PROCESS

- 10.1 The bid process can be postponed or cancelled at any stage, provided such cancellation or postponement takes place before entering into a contract with a specific service provider to which the bid relates.

Bidder's Initial/Signature: _____

SECTION 5**EVALUATION AND SELECTION PROCESS**

All bids received will be evaluated in accordance with the **80/20** preference point system as prescribed in the Preferential Procurement Regulation of 2022. The evaluation process comprises the following phases:

Phase 1: Screening process

During this phase, bids will be reviewed to determine whether a bidder complied with all standard bidding documents and whether a duly authorised representative signed such documents.

Phase 2: Functionality evaluation

The evaluation process will be based on the bidder's responses in respect of the bid proposal. Bidders who score a minimum qualifying score of 42 points or more out of 70 points on functionality will be considered for the next phase, i.e., sample evaluation.

Proposals will be evaluated on a scale of **0-5** in accordance with the criteria below. Rating will be as follows; 0= non-submission 1= poor; 2=Average; 3=Good; 4=Very Good and 5= Excellent.

FUNCTIONALITY CRITERIA – PHASE 2	WEIGHT
1. Proposed Methodology	
<p>The bidder must provide a detailed approach and methodology regarding the manufacturing, supply, delivery, and installation of the office furniture based on the specifications. A project execution/implementation plan detailing project activities or tasks, timelines and deliverables schedule including the following information.</p> <ul style="list-style-type: none"> • Project activities, timelines and deliverables that covers the project execution phases i.e., from production and manufacturing, ordering process, supply and delivery including installation of furniture (work break down structure) = 20 • Indicate capacity/resources in undertaking the project. Inclusive of human resources with experience to effectively fulfill service requirements of this nature and size. = 10 • Correction of incorrect/damaged items within ten (10) working days = 10 	40
2. Track Record and Experience	
<p>The bidder must have knowledge and experience to provide the office furniture. Submit documentary proof in the form of one (1) or more signed reference letters (on a letterhead of the referee, with contact details) confirming exact start and end dates of the contract(s) where similar services were rendered (as indicated in paragraph 27.3)</p> <p>Less than one (1) year of experience = 1 Point One (1) year up to two (2) years of experience = 2 Points More than Two (2) years up to three (3) years of experience = 3 Points More than Three (3) years up to five (5) years of experience = 4 Points More than Five (5) years = 5 points Non-submission and non-compliance of signed relevant reference letters will score zero (0) points.</p> <p>Points will be allocated based on the accumulated number of years of experience for bidders with experience in the services required. Note: The focus of the reference letters should address the relevant work experience in office furniture/ manufacturing. Purchase order, award letter/s and appointment letter/s will not be considered</p>	30
Functional Total	70
Threshold	42

Bidder's Initial/Signature: _____

Bid No: NPA 01-25/26	National Prosecuting Authority
Prepared By: Supply Chain Management Unit	
Bid Description: Supply, delivery and installation of Office furniture to the NPA offices for a period of three (3) years.	

The points scored for functionality evaluation will be calculated as follows.

$$Ps = \frac{so}{ms} \times Ap$$

Where:

Ps = points scored for functionality by bid under consideration

So = total score of bids under consideration

Ms= maximum possible score

Ap = points allocated for functionality

- i. The value scored for each criterion will be multiplied by the specified weight for the relevant criterion to obtain the marks scored for each criterion.
- ii. The scores for each criterion will be added to obtain the total score.
- iii. This score will be converted to a percentage and only bidders that have met or exceeded the minimum qualifying score on functionality will be evaluated and scored in terms (specific goals, preference points).
- iv. Bidders not meeting a minimum qualifying score on functionality will be disqualified.

Phase 3: Sample evaluation

During this phase, bidders that scored the highest points on specific goals/preference points will be invited to present material samples and must meet a minimum qualifying score of 15 points or more out of 30 points. **Failure to meet the required minimum qualifying score will result in disqualification.**

Note: All shortlisted bidders will be informed two (2) weeks in advance of the date and time to present their mock-up office furniture and chairs on-site at the bidder's premises.

Samples will be evaluated on a scale of **0-5** in accordance with the criteria below. The rating will be as follows: 0=non-submission, 1 =poor; 2 =Average; 3=Good; 4=Very Good and 5 =Excellent.

No.	Technical elements	WEIGHT
1.	Material used on office furniture and Chairs: <ul style="list-style-type: none"> ▪ Type of wood on: = 15 <ul style="list-style-type: none"> - Office workstations, - Tables, credenza, and cupboards ▪ Type of material durability: = 15 <ul style="list-style-type: none"> - Fabric, leather (bonded/genuine) on chairs - Bidder to demonstrate the ability to provide special chairs as per request (e.g. Ergonomic chairs) 	30
Total score		30
Threshold		15

The points scored for the sample evaluation will be calculated as follows:

$$Ps = \frac{so}{ms} \times Ap$$

Where:

Ps = points scored for sample evaluation by bid under consideration

So = total score of bid under consideration

Ms= maximum possible score

Ap = points allocated for sample evaluation

- The value scored for each criterion will be multiplied by the specified weight for the relevant criterion to obtain the total score for each criterion.

Bidder's Initial/Signature: _____

- The scores for each criterion will be added to obtain the total score.
- This total score will be divided by the maximum possible score and multiplied by the allocated points and **only** bidders that have met the minimum qualifying score will be considered.
- Bidders not meeting a minimum qualifying score will be disqualified.

Phase 4: Price and specific goals

Points scored for specific goals will be added to the points scored for price and the total will be rounded off to the nearest two decimal places.

Bidder's Initial/Signature: _____

SECTION 6**SPECIFICATION: SUPPLY, DELIVERY AND INSTALLATION OF OFFICE FURNITURE TO THE NPA OFFICES FOR A PERIOD OF THREE (3) YEARS****1. PURPOSE**

1.1 To appoint a service provider for the supply, delivery and installation of office furniture to NPA offices for a period of three (3) years.

2. SCOPE OF WORK

2.1 The Office furniture is purchased for the NPA offices regularly. Having a contract will ensure that the NPA will be able to render the service of the provision of office furniture more efficiently and without delays.

2.2 The contract will also ensure that all new furniture procured is of the same standard and quality.

3. CONTRACT DURATION

3.1 The contract is for a period of three (3) years.

4. LIST OF NPA OFFICES

SITE NAME	PHYSICAL ADDRESS
NPA Head Office (Pretoria)	VGM Building, 123 Westlake Avenue, Weavind Park, Silverton
Investigating Directorate (ID)	CSIR, Building 10F, Farm Scientia, Lynwood, Pretoria
DPP Pretoria	Prudential Building 2nd floor, 28 Church Street Square, Pretoria
SCCU Pretoria	Sinodale Sentrum, George Building, 7th floor, 28 Visagie Street, Pretoria
DPP Johannesburg	Innes Chambers, 51 Pritchard Street, Johannesburg
DPP Cape Town	NPA Building, 115 Leeuwen & Buitengracht Street, Cape Town
DDPP Gqeberha/Port Elizabeth	Wool Trust building, 18 Old Grahamstown Road, North End, Gqeberha/Port Elizabeth
DDPP East London	Spoornet Building, 17 Fleet Street, East London
DPP Mthatha	Lower Sisson and Sutherland Streets, Fortgate, Mthatha
DPP Bhisho	Tourism Building, Magistrate Court, Palo Ave, Bhisho
DPP Grahamstown/Makhana	High Court Building, 94 High Street, Grahamstown/Mthatha
SCCU Cape Town	Commissioner House, Cnr. West & Voortrekker Streets, Bellville, Cape Town
DPP Kimberley	Wilco House, 22 Fabricia Road, Beaconsfield, Kimberley
DPP Bloemfontein	Waterval Building c/o Aliwal & St. Andrews Streets, Bloemfontein
DPP Mmabatho	Mega City East Gallery, 3139 Sekame Street, Mafikeng
DDPP Thohoyandou	Thohoyandou High Court, Mphephu Drive, Thohoyandou

Bidder's Initial/Signature: _____

Bid No: NPA 01-25/26		National Prosecuting Authority
Prepared By: Supply Chain Management Unit		
Bid Description: Supply, delivery and installation of Office furniture to the NPA offices for a period of three (3) years.		
DDPP Durban	Southern Life Building 3rd Floor,88 Joe Slovo Street, Durban	
SCCU Durban	John Ross House, Victoria Embankment, Durban	
DPP Pietermaritzburg	7th Floor, 286 Pietermaritz Street, Pietermaritzburg	
DPP Mpumalanga	Mpumalanga Division of the High Court, 52 Samora Machel and Kaapsehoop Streets, Nelspruit	
DDPP Middleburg	ERF/54 OR Tambo Street Middelburg	
DPP Polokwane	High Court Building 1 th Floor,36 Biccard Street, Polokwane	

5. All sizes of the office furniture and equipment are prescribed on the attached furniture and equipment **NORMS AND STANDARDS** item specifications document attached - **Annexure A.**

Bidder's Initial/Signature: _____

SECTION 7**SBD 6.1****PREFERENCE POINTS CLAIM FORM IN TERMS OF THE PREFERENTIAL PROCUREMENT REGULATIONS 2022**

This preference form must form part of all tenders invited. It contains general information and serves as a claim form for preference points for specific goals.

NB: BEFORE COMPLETING THIS FORM, TENDERERS MUST STUDY THE GENERAL CONDITIONS, DEFINITIONS AND DIRECTIVES APPLICABLE IN RESPECT OF THE TENDER AND PREFERENTIAL PROCUREMENT REGULATIONS, 2022

1. GENERAL CONDITIONS

1.1 The following preference point systems are applicable to invitations to tender:

- the 80/20 system for requirements with a Rand value of up to R50 000 000 (all applicable taxes included); and
- the 90/10 system for requirements with a Rand value above R50 000 000 (all applicable taxes included).

1.2 To be completed by the organ of state

- a) Either the 90/10 or 80/20 preference point system will be applicable in this tender. The lowest/highest acceptable tender will be used to determine the accurate system once tenders are received.

1.3 Points for this tender (even in the case of a tender for income-generating contracts) shall be awarded for:

- (a) Price; and
(b) Specific Goals.

1.4 To be completed by the organ of state:

The maximum points for this tender are allocated as follows:

	POINTS
PRICE	80
SPECIFIC GOALS	20
Total points for Price and SPECIFIC GOALS	100

1.5 Failure on the part of a tenderer to submit proof or documentation required in terms of this tender to claim points for specific goals with the tender, will be interpreted to mean that preference points for specific goals are not claimed.

1.6 The organ of state reserves the right to require of a tenderer, either before a tender is adjudicated or at any time subsequently, to substantiate any claim in regard to preferences, in any manner required by the organ of state.

Bidder's Initial/Signature: _____

2. DEFINITIONS

- (a) **“tender”** means a written offer in the form determined by an organ of state in response to an invitation to provide goods or services through price quotations, competitive tendering process or any other method envisaged in legislation.
- (b) **“price”** means an amount of money tendered for goods or services, and includes all applicable taxes less all unconditional discounts;
- (c) **“Rand value”** means the total estimated value of a contract in Rand, calculated at the time of bid invitation, and includes all applicable taxes;
- (d) **“tender for income-generating contracts”** means a written offer in the form determined by an organ of state in response to an invitation for the origination of income-generating contracts through any method envisaged in legislation that will result in a legal agreement between the organ of state and a third party that produces revenue for the organ of state, and includes, but is not limited to, leasing and disposal of assets and concession contracts, excluding direct sales and disposal of assets through public auctions; and
- (e) **“The Act”** means the Preferential Procurement Policy Framework Act, 2000 (Act No. 5 of 2000).

3. FORMULAE FOR PROCUREMENT OF GOODS AND SERVICES

3.1. POINTS AWARDED FOR PRICE

3.1.1 THE 80/20 OR 90/10 PREFERENCE POINT SYSTEMS

A maximum of 80 or 90 points is allocated for price on the following basis:

$$Ps = 80 \left(1 - \frac{Pt - P_{min}}{P_{min}} \right) \quad \text{or} \quad Ps = 90 \left(1 - \frac{Pt - P_{min}}{P_{min}} \right)$$

Where

Ps = Points scored for price of tender under consideration

Pt = Price of tender under consideration

Pmin = Price of lowest acceptable tender

3.2. FORMULAE FOR DISPOSAL OR LEASING OF STATE ASSETS AND INCOME GENERATING PROCUREMENT

3.2.1. POINTS AWARDED FOR PRICE

A maximum of 80 or 90 points is allocated for price on the following basis:

$$Ps = 80 \left(1 + \frac{Pt - P_{max}}{P_{max}} \right) \quad \text{or} \quad Ps = 90 \left(1 + \frac{Pt - P_{max}}{P_{max}} \right)$$

Where

Ps = Points scored for price of tender under consideration

Pt = Price of tender under consideration

Pmax = Price of highest acceptable tender

4. POINTS AWARDED FOR SPECIFIC GOALS

- 4.1. In terms of Regulation 4(2); 5(2); 6(2) and 7(2) of the Preferential Procurement Regulations, preference points must be awarded for specific goals stated in the tender. For the purposes of this tender the tenderer will be allocated points based on the goals stated in table 1 below as may be supported by proof/ documentation stated in the conditions of this tender:

Bidder's Initial/Signature: _____

- 4.2. In cases where organs of state intend to use Regulation 3(2) of the Regulations, which states that, if it is unclear whether the 80/20 or 90/10 preference point system applies, an organ of state must, in the tender documents, stipulate in the case of—
- (a) an invitation for tender for income-generating contracts, that either the 80/20 or 90/10 preference point system will apply and that the highest acceptable tender will be used to determine the applicable preference point system; or
 - (b) any other invitation for tender, that either the 80/20 or 90/10 preference point system will apply and that the lowest acceptable tender will be used to determine the applicable preference point system, then the organ of state must indicate the points allocated for specific goals for both the 90/10 and 80/20 preference point systems.

Table 1: Specific goals for the tender and points claimed are indicated per the table below.

(Note to organs of state: Where either the 90/10 or 80/20 preference point system is applicable, corresponding points must also be indicated as such.)

(Note to tenderers: The tenderer must indicate how they claim points for each preference point system.)

The specific goals allocated points in terms of this tender	Number of points allocated (90/10 system) (To be completed by the organ of state)	Number of points allocated (80/20 system) (To be completed by the organ of state)	Number of points claimed (90/10 system) (To be completed by the tenderer)	Number of points claimed (80/20 system) (To be completed by the tenderer)
Enterprises with ownership of 51% or more by person/s who are Black persons		10		
Enterprises with ownership of 51% or more by person/s who are women		05		
Enterprises with ownership of 51% or more by person/s who are youth		03		
Enterprises with ownership of 51% or more by person/s with disability		02		

DECLARATION WITH REGARD TO COMPANY/FIRM

- 4.3. Name of company/firm.....
- 4.4. Company registration number:

Bidder's Initial/Signature: _____

4.5. TYPE OF COMPANY/ FIRM

- Partnership/Joint Venture / Consortium
- One-person business/sole propriety
- Close corporation
- Public Company
- Personal Liability Company
- (Pty) Limited
- Non-Profit Company
- State Owned Company

[TICK APPLICABLE BOX]

4.6. I, the undersigned, who is duly authorised to do so on behalf of the company/firm, certify that the points claimed, based on the specific goals as advised in the tender, qualifies the company/ firm for the preference(s) shown and I acknowledge that:

- i) The information furnished is true and correct;
- ii) The preference points claimed are in accordance with the General Conditions as indicated in paragraph 1 of this form;
- iii) In the event of a contract being awarded as a result of points claimed as shown in paragraphs 1.4 and 4.2, the contractor may be required to furnish documentary proof to the satisfaction of the organ of state that the claims are correct;
- iv) If the specific goals have been claimed or obtained on a fraudulent basis or any of the conditions of the contract have not been fulfilled, the organ of state may, in addition to any other remedy it may have –
 - (a) disqualify the person from the tendering process;
 - (b) recover costs, losses or damages it has incurred or suffered as a result of that person’s conduct;
 - (c) cancel the contract and claim any damages which it has suffered as a result of having to make less favourable arrangements due to such cancellation;
 - (d) recommend that the tenderer or contractor, its shareholders and directors, or only the shareholders and directors who acted on a fraudulent basis, be restricted from obtaining business from any organ of state for a period not exceeding 10 years, after the *audi alteram partem* (hear the other side) rule has been applied; and
 - (e) forward the matter for criminal prosecution, if deemed necessary.

..... SIGNATURE(S) OF TENDERER(S)	
SURNAME AND NAME:
DATE:
ADDRESS:

Bid No: NPA 01-25/26	National Prosecuting Authority
Prepared By: Supply Chain Management Unit	
Bid Description: Supply, delivery and installation of Office furniture to the NPA offices for a period of three (3) years.	

SECTION 8

SBD 4

BIDDER'S DISCLOSURE

1. PURPOSE OF THE FORM

Any person (natural or juristic) may make an offer or offers in terms of this invitation to bid. In line with the principles of transparency, accountability, impartiality, and ethics as enshrined in the Constitution of the Republic of South Africa and further expressed in various pieces of legislation, it is required for the bidder to make this declaration in respect of the details required hereunder.

Where a person/s are listed in the Register for Tender Defaulters and / or the List of Restricted Suppliers, that person will automatically be disqualified from the bid process.

2. Bidder's declaration

- 2.1 Is the bidder, or any of its directors / trustees / shareholders / members / partners or any person having a controlling interest ¹ in the enterprise, employed by the state? **YES/NO**
- 2.1.1 If so, furnish particulars of the names, individual identity numbers, and, if applicable, state employee numbers of sole proprietor/ directors / trustees / shareholders / members/ partners or any person having a controlling interest in the enterprise, in the table below.

Full Name	Identity Number	Name of State institution

- 2.2 Do you, or any person connected with the bidder, have a relationship with any person who is employed by the procuring institution? **YES/NO**
- 2.2.1 If so, furnish particulars:
.....
.....

- 2.3 Does the bidder or any of its directors / trustees / shareholders / members / partners or any person having a controlling interest in the enterprise have any interest in any other related enterprise, whether or not they are bidding for this contract? **YES/NO**
- 2.3.1 If so, furnish particulars:

¹ the power, by one person or a group of persons holding the majority of the equity of an enterprise, alternatively, the person/s having the deciding vote or power to influence or to direct the course and decisions of the enterprise.

Bidder's Initial/Signature: _____

Bid No: NPA 01-25/26	National Prosecuting Authority
Prepared By: Supply Chain Management Unit	
Bid Description: Supply, delivery and installation of Office furniture to the NPA offices for a period of three (3) years.	

.....
.....

3 DECLARATION

I, the undersigned, (name) in submitting the accompanying bid, do hereby make the following statements that I certify to be true and complete in every respect:

- 3.1 I have read and I understand the contents of this disclosure;
- 3.2 I understand that the accompanying bid will be disqualified if this disclosure is found not to be true and complete in every respect.
- 3.3 The bidder has arrived at the accompanying bid independently from, and without consultation, communication, agreement or arrangement with any competitor. However, communication between partners in a joint venture or consortium ² will not be construed as collusive bidding.
- 3.4 In addition, there have been no consultations, communications, agreements or arrangements with any competitor regarding the quality, quantity, specifications, prices, including methods, factors or formulas used to calculate prices, market allocation, the intention or decision to submit or not to submit the bid, bidding with the intention not to win the bid and conditions or delivery particulars of the products or services to which this bid invitation relates.
- 3.4 The terms of the accompanying bid have not been, and will not be, disclosed by the bidder, directly or indirectly, to any competitor, prior to the date and time of the official bid opening or of the awarding of the contract.
- 3.5 There have been no consultations, communications, agreements or arrangements made by the bidder with any official of the procuring institution in relation to this procurement process prior to and during the bidding process except to provide clarification on the bid submitted where so required by the institution; and the bidder was not involved in the drafting of the specifications or terms of reference for this bid.
- 3.6 I am aware that, in addition and without prejudice to any other remedy provided to combat any restrictive practices related to bids and contracts, bids that are suspicious will be reported to the Competition Commission for investigation and possible imposition of administrative penalties in terms of section 59 of the Competition Act No 89 of 1998 and or may be reported to the National Prosecuting Authority (NPA) for criminal investigation and or may be restricted from conducting business with the public sector for a period not exceeding ten (10) years in terms of the Prevention and Combating of Corrupt Activities Act No 12 of 2004 or any other applicable legislation.

I CERTIFY THAT THE INFORMATION FURNISHED IN PARAGRAPHS 1, 2 and 3 ABOVE IS CORRECT. I ACCEPT THAT THE STATE MAY REJECT THE BID OR ACT AGAINST ME IN TERMS OF PARAGRAPH 6 OF PFMA SCM INSTRUCTION 03 OF 2021/22 ON PREVENTING AND COMBATING ABUSE IN THE SUPPLY CHAIN MANAGEMENT SYSTEM SHOULD THIS DECLARATION PROVE TO BE FALSE.

.....
Signature Date
.....
Position Name of bid

² Joint venture or Consortium means an association of persons for the purpose of combining their expertise, property, capital, efforts, skill and knowledge in an activity for the execution of a contract.

Bidder's Initial/Signature: _____

Bid No: NPA 01-25/26	National Prosecuting Authority
Prepared By: Supply Chain Management Unit	
Bid Description: Supply, delivery and installation of Office furniture to the NPA offices for a period of three (3) years.	

SECTION 9

Declaration

I/We have examined the information provided in your bid documents and offer to undertake the work prescribed in accordance with the requirements as set out in the bid document. The prices quoted in this bid are fixed and valid for the stipulated period. I/We confirm the availability of the proposed team members/ and or services. We confirm that this bid will remain binding upon us and may be accepted by you at any time before the expiry date.

Signature of bidder:

Date:

Are you duly authorized to commit the bidder: YES / NO

Capacity under which this bid is signed

Domicilium

NPA chooses the following as its domicilium citandi et executandi for all purposes of and in connection with the final contract:
NATIONAL PROSECUTING AUTHORITY, VGM BUILDING, WEAVIND PARK, 123 WEST LAKE AVENUE, SILVERTON, PRETORIA

.....

The bidder must indicate its domicilium citandi et executandi for all purposes of and in connection with the final contract.

.....

Any discrepancies between the information supplied here and the other parts of the bid may result in your bid being disqualified.

Bidder's Initial/Signature: _____

Bid No: NPA 01-25/26	National Prosecuting Authority
Prepared By: Supply Chain Management Unit	
Bid Description: Supply, delivery and installation of office furniture to the NPA Offices for a period of three (3) years.	

SECTION 10

Bidder's Experience

NAME OF BIDDER:	BID NO.: NPA 01-25/26
-----------------------	------------------------------

[Note to the Bidder: The bidder must complete the information set out below in response to the requirements stated in section 3, paragraph 27.3 of this bid document. If the bidder requires more space than the provided below, the bidder must prepare a document in same format setting out all the information referred to and return it with the proposal.]

The bidder must provide the following information: (a) Details of the bidder's current and past projects of a similar type, size and complexity to the required services set out for this bid.

Clients' Name, contact person and contact details.	Project description	Project Cost	Project period (Start and End Dates)	Description of service performed and extent of Bidder's responsibilities
e.g. ABC Trading	e.g. Supply, delivery and installation of office furniture	e.g. R300 00.00	e.g. 1 March 2020 – 31 March 2021	e.g. Manufacture of office furniture

Bid No: NPA 01-25/26	National Prosecuting Authority
Prepared By: Supply Chain Management Unit	
Bid Description: Supply, delivery and installation of Office furniture to the NPA offices for a period of three (3) years.	

SECTION 11

PRICING SCHEDULE

Name of Bidder:	Bid Number: NPA 01-25/26
Closing Time: 11h00.....	Closing Date: 01 December 2025

Bidders are required to indicate a unit price and total price **all expenses** (VAT Inclusive).

No.	Category	Item Description	Estimated Qty	Estimated Unit Price (VAT Incl.)	Estimated Total Price (VAT Incl.)
1.	Workstation	Clerical Workstation Code: NPA-WS-600-600 L/R	64	R	R
2.	Workstation	Executive Workstation Code: NPA-WS-EX-L/R	12	R	R
3.	Chair	High back swivel and tilt gas adjustment, foam seat. Height-adjustable armrest, lumbar support, permanent contact mechanism, tension adjustment. Weight to accommodate 120 kg black bonded leather	70	R	R
4.	Chair	Executive sleigh base meeting/visitors chair, medium back, arm rest, sleigh, and back bonded leather Code: NPA-CHAIR-EX-SB-L	80	R	R
5.	Reception Chairs	Gas height adjustment and back rest adjustment and arm rests, with castors	10	R	R
6.	Visitors Chair	Classic designer chair with chromed wishbone arm & upholstered seat & back in bonded leather. Chrome sleigh base Code: NPA-CHAIR-SB-V-X	200	R	R
7.	Chair	High back-office chairs: with castors. Classic designer chair with chromed wishbone arm & upholstered seat & back in bonded leather. Standard with synchrony mechanism Code: NPA-CHAIR-HB-O-X	200	R	R
8.	Dustbin	Black stainless steel round punch/perforated waste bin 240mm (D) X 300mm (H) Code: NPA-BIN-ME	163	R	R
9.	Hat and Coat	Steel hat and coat hanger with brass hooks.	30	R	R
10.	Letter Trays	Stackable perforated steel, colour black	30	R	R
11.	Letter Trays	Wooden letter trays, Colour Vancouver Maple	8	R	R

Bidder's Initial/Signature: _____

Bid No: NPA 01-25/26		National Prosecuting Authority			
Prepared By: Supply Chain Management Unit					
Bid Description: Supply, delivery and installation of Office furniture to the NPA offices for a period of three (3) years.					
12.	Steel Filing Cabinets	4 drawer lockable steel filing cabinet. 1320mm X 470mm X 630mm, with security bar. Colour Ivory	25	R	R
13.	Heavy Duty Trolley	Overall Size: W 590mm x D 800mm x H 1330mm Fixed Toe Plate: W 400mm x D 275mm Folding Toe Plate: W 330mm x D 535mm Capacity: 400kg Wheels: 250mm Diameter Colour: Silver	1	R	R
14.	Table	Consultative table 4 Code: NPA-TABLE-TC-CN-1600	37	R	R
15.	Table	Boardroom table 16-seater leather-inlay Code: NPA-TABLE-EX-B-16	1	R	R
16.	Table	Table 1500 Round 6-seater Code: NPA -TABLE-M-6	4	R	R
17.	General Trolley	General trolley Code: NPA-TROLLEY-G	1	R	R
18.	High Back Chair	Executive high back swivel and tilt gas adjustment, foam seat. Height-adjustable armrest, lumber support, permanent contact mechanism, tension adjustment. Weight to accommodate 150 kg black bonded leather	17	R	R
19.	High Back Chair	Executive high back swivel and tilt gas adjustment, foam seat. Height-adjustable armrest, lumber support, permanent contact mechanism, tension adjustment. Weight to accommodate 200-220kg black bonded leather Code: NPA-CHAIR-EX-HB-L	10	R	R
20.	Cupboard	Executive cupboard with glass door Code: NPA-FC-EC-DOOR	8	R	R
21.	Cupboard	Standard Office Cupboard Code: NPA-FC-3-SC	204	R	R
22.	Cupboard	Credenza Executive Code: NPA-FC-CR-EX	10	R	R
23.	Cupboard	Executive Library Cupboard Code: NPA-FC-LC-EX	20	R	R
24.	Cupboard	Executive mobile pedestal Code: NPA-FC-MP-EX	10	R	R
25.	Top Retrieval Filing Unit:	Executive Top Retrieval Filing Unit Code: NPA-FC-ETR-5	8	R	R
26.	Workstation	PA Workstation 2way Code: NPA-WS-CLUS-600-1200-600-2	4	R	R
27.	Executive Boardroom	26-seater executive boardroom Code: NPA-TABLE-EX-B-26	1	R	R

Bidder's Initial/Signature: _____

Bid No: NPA 01-25/26		National Prosecuting Authority			
Prepared By: Supply Chain Management Unit					
Bid Description: Supply, delivery and installation of Office furniture to the NPA offices for a period of three (3) years.					
28.	Chair	Single Seater Chair leather, medium back, arm rest, sleigh, and back bonded leather Code: NPA-CHAIR-EX-SB-L	154	R	R
29.	Table	Consultative table 2 seater	106		
30.	Table	Serving table - Mlide 47.2 Inch Office Desk Thickened MDF Serving Table Colo Vancouver Mapler Code: NPA-TABLE-2-MU-2	2	R	R
31.	Table	Coffee table Code: NPA-TABLE-C-600	2	R	R
32.	Table	Coffee table Code: NPA-TABLE-C-900	1	R	R
33.	Table	Correspondence Code: 15- Division-Table - NPA-FC-15-CM	1	R	R
34.	Table	Correspondence-32- Division Code: Table NPA-FC-32-CS	1	R	R
35.	Table	Correspondence-6- Division Code: Table NPA-FC-6-CT	1	R	R
36.	Shelving	Steel Shelving	100	R	R
37.	Shelving	Retractable shelving for Document center	25	R	R
38.	Boards	Magnetic white boards	30	R	R
39.	Table	Kitchen stainless steel Tables	20	R	R
40.	Boardroom Table	26 Seater	2	R	R
41.	Workstation	Oversized workstation	139	R	R
42.	Couch	2 Seater Couches	12	R	R
43.	Couch	1 Seater	12	R	R
44.	Trolley	Mail Centre Trolley	3	R	R
	Category	Item Description not on the Norms & Standards	Estimated Qty	Estimated Unit Price (VAT Incl.)	Estimated Total Price (VAT Incl.)
45.	Double Door Steel Cabinet	91.5cm wide x 40cm deep x 140cm tall (36" wide x 15.75" deep x 55.11" tall inches) 4 Shelves height adjustable, Lock system key, Colour steel Ivory with two doors, solid steel side panel	197		
46.	Couch	3-seater Couches Height · 82 cm; Width · 213 cm; Depth · 87.3 cm; Seat Height · 44.7 cm; Weight Capacity · 130 kg.	10		

Bidder's Initial/Signature: _____

Bid No: NPA 01-25/26		National Prosecuting Authority		
Prepared By: Supply Chain Management Unit				
Bid Description: Supply, delivery and installation of Office furniture to the NPA offices for a period of three (3) years.				
47.	Boards	Magnetic year Planners sizes: 1200mm x 900 mm, 1500mm x 1200mm	15	
48.	Reception	Reception Area Counter (reception counter, practical. It can be all wood. Seats 2 with 2x3 or 4 drawers)	4	
49.	Table	Serving table - Mlide 47.2 Inch Office Desk Thickened MDF Serving Table 1200 x 400x 900H Server Unit – Top 1200 x 400 x 16mm	8	
50.	Trolley	Kitchen Trolley Wooden range 46 x 78 x 79 cm oak	5	
TOTAL BID AMOUNT (INCLUDING ALL APPLICABLE COSTS)				R

Conditions applicable to the bidders' pricing:

- The bidders must complete the pricing schedule (inclusive of any escalation and/or all costs deemed necessary as no additional costs will be admitted later.)
- All prices must be quoted in South African Rands. Prices are to remain fixed and valid for the duration of the contract. Non-fixed prices will not be considered.
- The unit price completed must include VAT (if applicable) and include all operating and any other applicable costs.
- The pricing schedule contains a column in which the estimated quantities are reflected.
- Cost of protective packaging and delivery must be included.

Bidders MUST complete the above pricing schedule in full, not part thereof. Failure to complete the pricing schedule in full will result in disqualification.

Declaration

I/We have examined the information and conditions provided in the pricing schedule. I/We confirm that the prices quoted in this bid are fixed and valid for the stipulated period.

Signature of bidder:

Date:

Bidder's Initial/Signature: _____

ANNEXURE A



National Prosecuting Authority

Building Norms & Standards

Phase 1:

National Furniture & Equipment Standards & Norms



Furniture & Equipment Standards & Norms

1. Office Appliances
2. Bins
3. Bulk Filing
4. Cupboards
5. Pin Boards
6. Pull Down Screens
7. Screens (Furniture)
8. Seating
9. Shelving & Racks
10. Smart Boards
11. Tables
12. Trolleys
13. White Boards
14. Workstations
15. Workstation Additions

Acronyms

FB	-	FRIDGE BAR
UF	-	UPRIGHT FRIDGE
MW	-	MICROWAVE
SH	-	SHREDDER
TP	-	TELEPHONE PEDESTAL
MP	-	MOBILE PEDESTAL
CT	-	CORRESPONDENCE TABLE
CS	-	CORRESPONDANCE
EX	-	EXECUTIVE
EFP	-	EXECUTIVE FIXED PEDESTAL
FP	-	FIXED PEDESTAL
ETR	-	EXECUTIVE TOP RETRIEVAL
TR	-	TOP RETRIEVAL
FC	-	FILLING CUPBOARD
S	-	SERVER
LC	-	LIBRARY CUPBOARD
EC	-	EXECUTIVE CUPBOARD
CR	-	CREDENZA
PE	-	PEDENZA
SC	-	STANDARD CUPBOARD
OB	-	OPEN BOOK SHELF
BF	-	BULK FILER
PB	-	PIN BOARD
PDS	-	PULL DOWN SCREEN
F	-	FURNITURE
HB	-	HIGHBACK
SB	-	SLEIGHBASE
V	-	VISITOR
CO	-	COUCH COLOR ADD
SS	-	SINGLE SEATER
DS	-	DOUBLE SEATER
PC	-	POLYPROYLENE CHAIR
L	-	LEATHER
CC	-	CONFERENCE CHAIR
SR	-	STEEL RACK
IW	-	INTERACTIVE WHITEBOARD
B	-	BOARDROOM
CCD	-	CALL CENTRE DESK
RH	-	RIGHT HANDED
LH	-	LEFT HANDED
ST	-	SANGRIA TABLE
DT	-	DIABLO TABLE
C	-	COFFEE TABLE
CPT	-	CONSULTANT PC TABLE
CN	-	CONSULTANT
TC	-	TABLE CONSULTANT
MR	-	MEETING ROOM
M	-	MEETING
MU	-	MULTI USE
MA	-	MAIL
G	-	GENERAL
P	-	PROCESSING
T	-	TEA
WB	-	WHITE BOARD
CLUS	-	CLUSTER
SU	-	SUPPORT
PL	-	PLASTIC
ME	-	METAL
VM	-	VANCOUVER MAPLE
CM	-	CORRESPONDANCE

APPLIANCES: OFFICE



BAR FRIDGE: NPA-FB-O KELVINATOR (or similar or equal)

Draft



Manufacturer: Kelvinator
Model: KI130
Product: Bar fridge
Capacity: 130 litres
Finish: Brushed steel
Features:
-Interior light
-Adjustable shelves
-Adjustable thermostat
-Flush bulk section
-Leveling feet
Warranty: Two years

CODE Description

FB

CATEGORY

O

OFFICE

Barcode:

NPA issued barcode to be fixed to top before delivery to site.

NOTES:

- Cost of installation to include delivery.
- Location of delivery to be confirmed with Facilities Manager on site prior to delivery.
- Warranty: Unit to be supplied with minimum 2 year warranty under normal office usage conditions. The specifications as contained in this document are the minimum NPA requirements. Vendor to take design responsibility & ensure correct specifications.



APPLIANCES: OFFICE



UPRIGHT FRIDGE: Code: NPA-UF-O^{Draft} KELVINATOR (or similar or equal to)



Manufacturer: Kelvinator
Product: Upright fridge
Capacity: 250 - 300litres
Finish: Brushed steel
Features:
-Reversible doors
-Auto cycle defrost
-Adjustable thermostat
-Energy saving & low noise
-Clear crisper drawer
-Integrated handles
-600 x 580 x 1480 (W x D x H)
-Leveling feet

Warranty: Two years

CODE Description

UF

CATEGORY

O

OFFICE

Barcode:

NPA issued barcode to be fixed to top before delivery to site.

NOTES:

- Cost of installation to include delivery.
- Location of delivery to be confirmed with Facilities Manager on site prior to delivery.
- Warranty: Unit to be supplied with minimum 2 year warranty under normal office usage conditions. The specifications as contained in this document are the minimum NPA requirements. Vendor to take design responsibility & ensure correct specifications.



APPLIANCES: OFFICE



MICROWAVE: Code: NPA-MW-O^{Draft} KELVINATOR (or similiar or equal)



Manufacturer: Kelvinator
Model: KM 28 ECS
Product: Microwave Oven with Grill & Convection cooking
Capacity: 28 litres
Finish: Brushed steel
Interior: Stainless steel
Features:
-Interior light
-5 programmes
-Defrost by weight programmes
-Auto function
-2 Stage cooking
-Lock function for children
-Fast cooking mode
-Clock / Preset setting
-512 x 441 x 307 (LxWxH)
Warranty: Two years

CODE Description

MW

CATEGORY

O

RESIDENTIAL/
OFFICE

Barcode:

NPA issued barcode to be fixed to top before delivery to site.

NOTES:

- Cost of installation to include delivery.
- Location of delivery to be confirmed with Facilities Manager on site prior to delivery.
- Warranty: Unit to be supplied with minimum 2 year warranty under normal office usage conditions. The specifications as contained in this document are the minimum NPA requirements. Vendor to take design responsibility & ensure correct specifications.



APPLIANCES: OFFICE



SHREDDER: Code: NPA-SH-O-1 Draft FELLOWES (or similar or equal to)



Manufacturer: FELLOWES or similar or equal
Model: PS - 70
Product: Paper shredded
Dimensions: 510H X 280D X 400W
Warranty: Five years

CODE Description

SH

CATEGORY

O

OFFICE

Barcode:

NPA issued barcode to be fixed to top before delivery to site.

NOTES:

- Cost to include delivery.
- Location of delivery to be confirmed with Facilities Manager on site prior to delivery
- Plasticised sticker fixed out of sight. Stating: Supplier, physical address and contact details.
- Warranty: Unit to be supplied with minimum 5 year warranty under normal office usage conditions. The specifications as contained in this document are the minimum NPA requirements. Vendor to take design responsibility & ensure correct specifications.



APPLIANCES: OFFICE



SHREDDER: Code NPA-SH-O-2 Draft REXEL (or similiar or equal to)



Manufacturer: REXEL or similar or equal
Model: ACCO 1400
Product: Paper shredded

Warranty: Five years

CODE Description

SH

CATEGORY

O

OFFICE

Barcode:

NPA issued barcode to be fixed to top before delivery to site.

NOTES:

- Cost to include delivery.
- Location of delivery / fitment to be confirmed with Facilities Manager on site prior to actual installation.
- Plasticised sticker fixed out of sight. Stating: Supplier, physical address and contact details.
- Warranty: Unit to be supplied with minimum 5 year warranty under normal office usage conditions. The specifications as contained in this document are the minimum NPA requirements. Vendor to take design responsibility & ensure correct specifications.



APPLIANCES: OFFICE



Draft TV: Sony-W Series: CODE: NPA-TV-O KLV-32W400A / KLV32S400 (or similar or equal)



Model :

LCD Screen Size :32" (81cm), 16:9
TV System :M, B/G, D/K, I
Colour System :NTSC 3.58, PAL, SECAM, NTSC 4.43 (AV In), PAL 60 (AV In)
Video Signal :480i, 576i, 480p, 576p, 1080i, 720p, 1080p

Picture

Display Resolution :1920 x 1080
Video Processing :BRAVIA Engine 2
Panel Bit :8-bit Panel
Backlight Module :CCFL
Advanced Contrast Enhancer (ACE) :Yes
Theatre Mode :Yes
24P True Cinema :Yes
MPEG Noise Reduction :Yes
Dynamic Contrast :33000:1
Panel Contrast :3000:1
Viewing Angle :178°
Screen Format :Wide Zoom / Normal / Full / Zoom
Picture Mode :Vivid / Standard / Cinema / Photo
3D Digital Comb Filter :Yes

Audio

Sound Mode :Dynamic / Standard / Clear Voice
Surround Mode :S-Force / Simulated Stereo
Voice Zoom :Yes
Surround :S-Force
Stereo System :NICAM, A2
Audio Output Power :10W + 10W

Terminals

HDMI / Audio In :3/1
Digital Media Port :1
Component / Audio In :2
Composite / Audio In :3
HD15 PC Input / Audio :1
Composite Monitor Out / Audio Out

Other Features

BRAVIA Sync :Yes
Power Saving Mode :Yes
Clock :Yes
PAP (Picture And Picture) :Yes (1 tuner)
PC Input PIP (Picture In Picture) :Yes
Ambient Light Sensor :Yes
OSD Language :English / Traditional Chinese / Thai / Arabic / Persian
Swivel / Tilt :Yes / -
Swivel Range :Left 20° / Right 20°

General

Power Requirements :110-240V 50/60 Hz
Power Consumption :170W
Standby Power Consumption :Less than 0.3W
Dimensions (W x H x D) with Stand :794 x 577 x 242 mm
Dimensions (W x H x D) without Stand :794 x 540 x 99 mm
Weight with Stand :16kg
Weight without Stand :13kg

Supplied Accessories

Remote Control :RM-GA011
Batteries :2 x AA
Sleep Timer :Yes
On/Off Timer (with Time Setting) :Yes
Teletext

CODE Description

TV

CATEGORY

O

OFFICE

Barcode:

NPA issued barcode to be fixed to top before delivery to site.

NOTES:

- Cost of installation to include delivery.
- Location of delivery to be confirmed with Facilities Manager on site prior to delivery.
- Plasticised sticker fixed out of sight, specifying: Supplier, contact details & physical address.
- Warranty: Unit to be supplied with minimum 2 year warranty under normal office usage conditions. The specifications as contained in this document are the minimum NPA requirements. Vendor to take design responsibility & ensure correct specifications.



DUSTBINS



Draft

EXECUTIVE OFFICE DUSTBIN Code: NPA-BIN-VM



DIMENSIONS: 300 x 300 x 300
FINISH COLOUR: Vancouver Maple
MATERIAL: Timber veneer

CODE Description

BIN	VM
CATEGORY	FINISH

Barcode:

NPA issued barcode to be fixed to side before delivery to site.

NOTE:
This dustbin is for use only at Executive offices.
Level 14 & UP

TECHNICAL DATA

DESCRIPTION: Substrate from high-density particle board, 22mm. All sides 0,7mm Vancouver Maple veneer surface. 2,5mm solid Maple edging with straight joints.

FINISH: First Coat sanding sealer, Fill board and sand down, Second Coat sanding sealer, Sand down, Apply colour if applicable, 3x Coats "Chemspec" or similar or equal product thinners based Gloss varnish with A-C catalyst, sprayed on. Allow to dry between coats

SIZE: 300d x 300w x 300h

SUPPLIER: Plasticised sticker fixed out of sight, stating supplier, physical address and contact details.

Warranty & DESIGN: All units to carry a minimum 5 year Warranty under normal office environment conditions. The specifications as contained in this document are the minimum NPA requirements. Vendor to take design responsibility and ensure correct specifications.



DUSTBINS



ADDIS or similar or equal CODE: NPA-BIN-PL

Draft



MANUFACTURER: ADDIS (or similar or equal)
PRODUCT: Plastic Dustbin with Flip-Lid
FINISH: Black
SIZE: 48 ltr

NOTE:
All products as specified or similar or equal.
NPA Facilities to sign off sample before order is placed.

CODE Description

BIN	PL
CATEGORY	FINISH

Barcode:

NPA issued barcode to be fixed to product before delivery to site.

SUPPLIER: Plasticised sticker fixed to bottom, stating: Supplier, physical address and contact details.

WARRANTY & DESIGN: All units to carry minimum of 5 years warranty under normal office environment conditions. The specifications as contained in this document are the minimum NPA requirements. Vendor to take design responsibility & ensure correct specifications.



DUSTBINS



Draft

METAL OFFICE DUSTBIN CODE: NPA-BIN-ME



FINISH COLOUR: Silver, Gloss
Material: Metal, perforated

CODE Description

BIN

CATEGORY

ME

FINISH

Barcode:

NPA issued barcode to be fixed to side before delivery to site.

TECHNICAL DATA

DESCRIPTION: Square punch perforated metal waste paper dustbin.
FINISH COLOUR: Silver, Gloss.
SUPPLIER: Plasticised sticker fixed out of sight, stating supplier, physical address and contact details.
Warranty & DESIGN: All units to carry a minimum 5 year Warranty under normal office environment conditions. The specifications as contained in this document are the minimum NPA requirements. Vendor to take design responsibility and ensure correct specifications.



BULK FILING SYSTEMS



Draft

1200w x 4bay bulk filer Code: NPA-BULK-BF-1200-4



Image: Locking 4 bay unit
(1x fixed, 1x double, 1x single bay,
NOTE: indicated for example only)

Max Width
= 1200mm

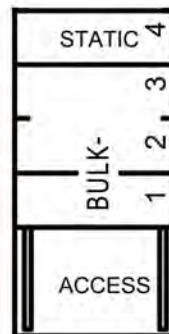

Barcode:

NPA issued barcode to be fixed to front before delivery to site.

CODE Description

BULK	BF	1200	4
CATEGORY	DESCRIPTION	WIDTH	NO. OF BAYS (INCL. STATIC)

NOTE:

- MAX height of Bulk Filing unit 2300.
- NO chain driven mechanism required.

FURNITURE PLAN LEGEND KEY:

- 4 Bay single width unit CAD symbol shown.
(1x Fixed, 1x double, 1x single.)

TECHNICAL DATA

- Weight:** Supplier to advise when quoting NPA if units loaded weight (bulk A4 paper) is likely to exceed 250 kg/m². This must be supplied in writing to the NPA buyer by vendor.
- Base:** Finish: Powder Coated black (matt). System design to manufacturers details. Carpet finish to base.
- Carcass:** Finish: Powder Coated Beige (matt). System design to manufacturers details.
- Lock:** 5 (five) lever lock required. Key's to be cut in triplicate.
- Handles:** NO chain driven mechanism required for single width 4 bay unit. Minimum protrusion handle design.
- Shelves:** Finish: Powder Coated Beige (matt). Interim supports to manufacturers specification. Double (back to back) units require sandwich sheet for stability. 7 physical storage shelves required (vertical).
Plasticised sticker fixed out of sight stating: Supplier, physical address and contact details.
- Supplier:** All units to carry a minimum 5 year warranty under normal office environment conditions.
- Warranty & Design:** The specifications as contained in this document are the minimum NPA requirements. Vendor to take design responsibility & ensure correct specifications.



BULK FILING SYSTEMS



Draft

1200w x 10bay bulk filer Code: NPA-BULK-BF-1200-10

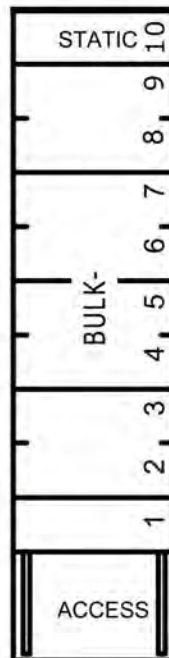

Image: Locking 4 bay unit
(1x fixed, 1x double, 1x single bay.
NOTE: indicated for example only.
Chain driven mechanism required)

NOTE:

- MAX height of Bulk Filing unit 2300.
- Chain driven mechanism required.

Max Width
= 1200mm



Max Length = 4800mm

CODE Description

BULK	BF	1200	10
CATEGORY	DESCRIPTION	WIDTH	NO. OF BAYS (INCL. STATIC)

Barcode:

NPA issued barcode to be fixed to front before delivery to site.

FURNITURE PLAN LEGEND KEY:

- 10 Bay single width unit CAD symbol shown.
(1x Fixed, 4x double, 1x single.)

TECHNICAL DATA

Weight:	Supplier to advise when quoting NPA if units loaded weight (bulk A4 paper) is likely to exceed 250 kg/m ² . This must be supplied in writing to the NPA buyer by vendor.
Base:	Finish: Powder Coated black (matt). System design to manufacturers details. Carpet finish to base.
Carcass:	Finish: Powder Coated Beige (matt). System design to manufacturers details.
Lock:	5 (five) lever lock required. Key's to be cut in triplicate.
Handles:	Chain driven or movement assisted mechanism required for single width 10 bay unit. Minimum protrusion handle design for movement assisted mechanism to allow close fit side by side placement of units.
Shelves:	Finish: Powder Coated Beige (matt). Interim supports to manufacturers specification. Double (back to back) units require sandwich sheet for stability. 7 physical storage shelves required (vertical).
Supplier:	Plasticised sticker fixed out of sight stating: Supplier, physical address and contact details.
Warranty & Design:	All units to carry a minimum 5 year warranty under normal office environment conditions. The specifications as contained in this document are the minimum NPA requirements. Vendor to take design responsibility & ensure correct specifications.



BULK FILING SYSTEMS



Draft

1200w x 12bay bulk filer Code: NPA-BULK-BF-1200-12



Image: "ZIPPEL" Locking 4 bay unit shown (1x fixed, 1x double, 1x single bay. NOTE: indicated for example only. Chain driven mechanism required)

Max Width
= 1200mm

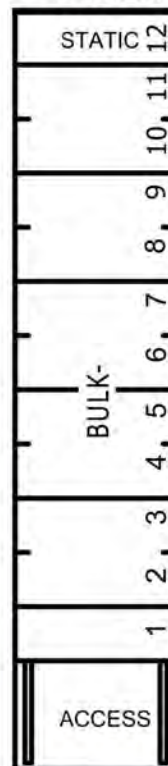

Max Length = 5600mm

CODE Description			
CATEGORY	DESCRIPTION	WIDTH	NO. OF BAYS (INCL. STATIC)
BULK	BF	1200	12

Barcode:

NPA issued barcode to be fixed to front before delivery to site.

NOTES:

- MAX height of Bulk Filing unit 2300.
- Chain driven mechanism required.

FURNITURE PLAN LEGEND KEY:

- 12 Bay single width unit CAD symbol shown. (1x Fixed, 5x double, 1x single.)

TECHNICAL DATA

Weight:	Supplier to advise when quoting NPA if units loaded weight (bulk A4 paper) is likely to exceed 250 kg/m ² . This must be supplied in writing to the NPA buyer by vendor.
Base:	Finish: Powder Coated black (matt). System design to manufacturers details. Carpet finish to base.
Carcass:	Finish: Powder Coated Beige (matt). System design to manufacturers details.
Lock:	5 (five) lever lock required. Key's to be cut in triplicate.
Handles:	Chain driven or movement assisted mechanism required for single width 12 bay unit. Minimum protrusion handle design for movement assisted mechanism to allow close fit side by side placement of units.
Shelves:	Finish: Powder Coated Beige (matt). Interim supports to manufacturers specification. Double (back to back) units require sandwich sheet for stability. 7 physical storage shelves required (vertical).
Supplier:	Plasticised sticker fixed out of sight stating: Supplier, physical address and contact details.
Warranty & Design:	All units to carry a minimum 5 year warranty under normal office environment conditions. The specifications as contained in this document are the minimum NPA requirements. Vendor to take design responsibility & ensure correct specifications.



BULK FILING SYSTEMS



Draft

1200w x 6bay bulk filer Code: NPA-BULK-BF-1200-6



Image: Locking 4 bay unit
(1x fixed, 1x double, 1x single bay.
NOTE: indicated for example only)

Max Width
= 1200mm

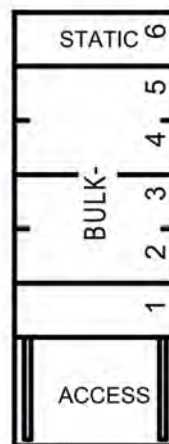

Max Length = 3200mm

Barcode:

NPA issued barcode to be fixed to front before delivery to site.

CODE Description

BULK	BF	1200	6
CATEGORY	DESCRIPTION	WIDTH	NO. OF BAYS (INCL. STATIC)

NOTE:

- MAX height of Bulk Filing unit 2300.
- NO chain driven mechanism required.

FURNITURE PLAN LEGEND KEY:

- 6 Bay single width unit CAD symbol shown.
(1x Fixed, 2x double, 1x single.)

TECHNICAL DATA

Weight:	Supplier to advise when quoting NPA if units loaded weight (bulk A4 paper) is likely to exceed 250 kg/m2. This must be supplied in writing to the NPA buyer by vendor.
Base:	Finish: Powder Coated black (matt). System design to manufacturers details. Carpet finish to base.
Carcass:	Finish: Powder Coated Beige (matt). System design to manufacturers details.
Lock:	5 (five) lever lock required. Key's to be cut in triplicate.
Handles:	NO chain driven mechanism required for single width 6 bay unit. Minimum protrusion handle design.
Shelves:	Finish: Powder Coated Beige (matt). Interim supports to manufacturers specification. Double (back to back) units require sandwich sheet for stability. 7 physical storage shelves required (vertical). Plasticised sticker fixed out of sight stating: Supplier, physical address and contact details.
Supplier: Warranty & Design:	All units to carry a minimum 5 year warranty under normal office environment conditions. The specifications as contained in this document are the minimum NPA requirements. Vendor to take design responsibility & ensure correct specifications.



BULK FILING SYSTEMS



Draft

1200w x 8bay bulk filer Code: NPA-BULK-BF-1200-8



Image: Locking 4 bay unit
(1x fixed, 1x double, 1x single bay.
NOTE: indicated for example only)

Max Width
= 1200mm

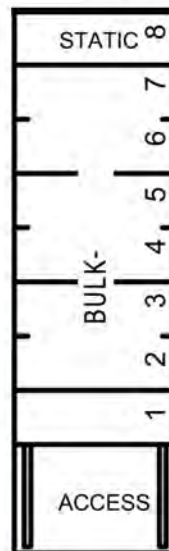

Max Length = 4000mm

CODE Description

CATEGORY	DESCRIPTION	WIDTH	NO. OF BAYS (INCL. STATIC)
BULK	BF	1200	8

Barcode:

NPA issued barcode to be fixed to front before delivery to site.

NOTE:

- MAX height of Bulk Filing unit 2300.
- NO chain driven mechanism required.

FURNITURE PLAN LEGEND KEY:

- 8 Bay single width unit CAD symbol shown.
(1x Fixed, 3x double, 1x single.)

TECHNICAL DATA

Weight:	Supplier to advise when quoting NPA if units loaded weight (bulk A4 paper) is likely to exceed 250 kg/m ² . This must be supplied in writing to the NPA buyer by vendor.
Base:	Finish: Powder Coated black (matt). System design to manufacturers details. Carpet finish to base.
Carcass:	Finish: Powder Coated Beige (matt). System design to manufacturers details.
Lock:	5 (five) lever lock required. Key's to be cut in triplicate.
Handles:	NO chain driven mechanism required for single width 8 bay unit. Minimum protrusion handle design.
Shelves:	Finish: Powder Coated Beige (matt). Interim supports to manufacturers specification. Double (back to back) units require sandwich sheet for stability. 7 physical storage shelves required (vertical). Plasticised sticker fixed out of sight stating: Supplier, physical address and contact details.
Supplier:	All units to carry a minimum 5 year warranty under normal office environment conditions.
Warranty & Design:	The specifications as contained in this document are the minimum NPA requirements. Vendor to take design responsibility & ensure correct specifications.



FURNITURE SPECIFICATIONS



Draft

CORRESPONDENCE-12-DIVISION CODE: NPA-FC-12-CS

Typical Correspondence 12 Division



FINISH



Vancouver Maple CDL

CAD Furniture Symbol:

CODE Description

FC	12	CS
CATEGORY	DIVISIONS	DESCRIPTION

Barcode:

NPA issued barcode to be on top of cabinet before delivery to site.

NOTE:

May NOT be used for Executive applications.

TECHNICAL INFORMATION

- Dimensions:** 1100mm wide x 400mm deep x 882mm high.
- Carcass:** Top & bottom from 22mm high-density particle board with surface of 0.6mm Deccon CDL. All other components 16mm high-density particle board with surface of Melawood. All divisions to be of equal measurements: 343w x 215h. All parts not exposed / visible to get 0.2mm brown backer.
- Finish:** Vancouver Maple CDL with 2mm maple finish flat edge high impact edging with straight joints.
- Supplier:** Plasticised sticker fixed out of sight, stating: Supplier, physical address and contact details.
- Warranty & Design:** All units to carry a minimum 5 year warranty under normal office environment conditions. The specifications as contained in this document are the minimum NPA requirements. Vendor to take design responsibility & ensure correct specifications.



FURNITURE SPECIFICATIONS



Draft

CORRESPONDENCE-15-DIV-MOBILE CODE: NPA-FC-15-CM

Typical Correspondence 15 division Mobile



FINISH



Vancouver Maple CDL

CAD Furniture Symbol:

CODE Description

FC	15	CM
CATEGORY	DIVISIONS	DESCRIPTION

Barcode:

NPA issued barcode to be on top of cabinet before delivery to site.

NOTE:

May NOT be used for Executive applications.

TECHNICAL INFORMATION

- Dimensions:** 900mm wide x 465mm deep x 1500mm high.
- Carcass:** Cupboard components from high-density particle board. All components 16mm high-density particle board with surface of Melawood. All divisions to be of equal measurements. All parts not exposed / visible to get 0.2mm brown backer.
- Finish:** Vancouver Maple CDL with 2mm maple finish flat edge high impact edging with straight joints.
- Wheels:** Nylon double acting castors to u/s. Runners to be metal with nylon rollers (Blum or similar).
- Supplier:** Plasticised sticker fixed out of sight, stating: Supplier, physical address and contact details.
- Warranty & Design:** All units to carry a minimum 5 year warranty under normal office environment conditions. The specifications as contained in this document are the minimum NPA requirements. Vendor to take design responsibility & ensure correct specifications.



FURNITURE SPECIFICATIONS



CORRESPONDENCE-32-DIVISION

Draft

CODE: NPA-FC-32-CS

Typical Correspondence 32 division



FINISH



Vancouver Maple CDL

CAD Furniture Symbol:



CODE Description

FC 32 CS

CATEGORY
DIVISION
DESCRIPTION

Barcode:

NPA issued barcode to be on top of cabinet before delivery to site.

NOTE:

May NOT be used for Executive applications.

TECHNICAL INFORMATION

- Dimensions:** 1120mm wide x 420mm deep x 1500mm high.
- Carcass:** Cupboard components from high-density particle board, top 22mm with surface of 0.6mm Deccon CDL. All components from 16mm board. All divisions to be of equal measurements. All parts not exposed / visible to get 0.2mm brown backer.
- Finish:** Vancouver Maple CDL with 2mm maple finish flat edge high impact edging with straight joints.
- Iron Mongery:** High strength 110degree 8mm cranked chrome hinges, each door to be hung with 2 hinges. Handles to be SaddleWood arch handles of 110mm length (Gelmar or equal or similar).
- Supplier:** Plasticised sticker fixed out of sight, stating: Supplier, physical address and contact details.
- Warranty & Design:** All units to carry a minimum 5 year warranty under normal office environment conditions. The specifications as contained in this document are the minimum NPA requirements. Vendor to take design responsibility & ensure correct specifications.



FURNITURE SPECIFICATIONS



Draft

CORRESPONDENCE-4-DIVISION-TABLE CODE: NPA-FC-4-CT

Typical Correspondence 4 Division Table Top



FINISH



Vancouver Maple CDL

CODE Description

FC	4	CT
CATEGORY	DIVISION	DESCRIPTION

Barcode:

NPA issued barcode to be on top of cabinet before delivery to site.

NOTE:

May NOT be used for Executive applications.

TECHNICAL INFORMATION

- Dimensions:** 1190mm wide x 340mm deep x 116mm high.
- Carcass:** All components from 16mm board with surface of Melawod. All divisions to be of equal 275mm measurements. All parts not exposed / visible to get 0.2mm brown backer.
- Finish:** Vancouver Maple CDL with 2mm maple finish flat edge high impact edging with straight joints.
- Supplier:** Plasticised sticker fixed out of sight, stating: Supplier, physical address and contact details.
- Warranty & Design:** All units to carry a minimum 5 year warranty under normal office environment conditions. The specifications as contained in this document are the minimum NPA requirements. Vendor to take design responsibility & ensure correct specifications.



FURNITURE SPECIFICATIONS



Draft

CORRESPONDENCE-6-DIVISION-TABLE CODE: NPA-FC-6-CT

Typical Correspondence 6 Division Table Top



FINISH



Vancouver Maple CDL

CODE Description

FC	6	CT
CATEGORY	DIVISION	DESCRIPTION

Barcode:

NPA issued barcode to be on top of cabinet before delivery to site.

NOTE:

May NOT be used for Executive applications.

TECHNICAL INFORMATION

Dimensions: 900mm wide x 340mm deep x 232mm high.

Carcass: All components 16mm high-density particle board with surface of Melawood. All divisions to be of equal 275 internal measurements. All parts not exposed / visible to get 0.2mm brown backer.

Finish: Vancouver Maple CDL with 2mm maple finish flat edge high impact edging with straight joints.

Supplier: Plasticised sticker fixed out of sight, stating: Supplier, physical address and contact details.

Guarantee & All units to carry a minimum 5 year warranty under normal office environment conditions.

Design: The specifications as contained in this document are the minimum NPA requirements. Vendor to take design responsibility & ensure correct specifications.



FURNITURE SPECIFICATIONS



Draft

CREDENZA Code: NPA-FC-CR

Typical Credenza



FINISH



Vancouver Maple CDL

CAD Furniture Symbol:

CODE Description

FC CR

CATEGORY

DESCRIPTION

Barcode:

NPA issued barcode to be on top of cabinet before delivery to site.

NOTE:

May NOT be used for Executive applications.

TECHNICAL DATA

- Dimensions:** 850 wide x 600 deep x 752 high (Incl. top).
Carcass: Top 32mm with surface of 0.6mm Decon CDL, all other components 16mm high-density particle board with surface of Melawood. Cupboard to contain 1 internal shelf from 1mm steel sheet - powder coated matt black for finish. Shelf height to be adjustable at approx 50mm vertical spacings. Edges bents to form 25mm square. All parts not exposed / visible to get 0.2mm brown backer.
Door: Horizontal roller shutter door, colour Saddlewood. Saddlewood arch handle of 110mm (Gelmar or equal or similar) for opening.
Finishes: Vancouver Maple CDL with 2mm maple finish flat edge high impact edging.
Locks: Independent central locking mechanism. 2 keys.
Supplier: Plasticised sticker fixed out of sight, stating: Supplier, physical address and contact details.
Warranty & Design: All units to carry a minimum 5 year warranty under normal office environment conditions. The specifications as contained in this document are the minimum NPA requirements. Vendor to take design responsibility & ensure correct specifications.



FURNITURE SPECIFICATIONS



Draft

EXECUTIVE CREDENZA CODE: NPA-FC-CR-EX

Executive Credenza



Executive Credenza to go with Exec WS.

FINISH



Vancouver Maple Veneer



45 degree chamfered top & connection with Exec Workstation

CAD Furniture Symbol:

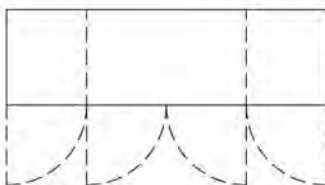

CODE Description

FC	CR	EX
CATEGORY	DESCRIPTION	TYPE

Barcode:

NPA issued barcode to be on top of cabinet before delivery to site.

NOTE:

May ONLY be used for Executive applications. Level 14 & UP

TECHNICAL INFORMATION

- Dimensions:** 2000 x600 x 752mm high.
- Counter top:** Substrate from high-density particle board, Top: 32mm, all other components 16mm. All with 0,7mm Vancouver Maple veneer surface. All parts not exposed / visible to get 0.2mm brown backer.
- Edging:** 2,5mm solid Vancouver Maple edging with straight joints.
- Finish:** VENEER: First Coat sanding sealer, Fill board and sand down, Second Coat sanding sealer, Sand down, Apply colour if applicable, 3x Coats "Chemspec" or similar or equal product thinners based High Gloss varnish with A-C catalyst, sprayed on. Allow to dry between coats.
BLACK: Spray paint Satin sheen Duco, Black.
- Shelf:** Internal shelf from 1mm steel sheet - powder coated matt black for finish. Adjustable at approx 50mm vertical spacings. Edges bent to form 25mm square.
- Handles:** Routed finger groove in top of doors.
- Iron mongery:** High strength 110degree 8mm cranked chrome hinges, each door to be hung with 2 hinges.
- Supplier:** Plasticised sticker fixed out of sight, stating: Supplier, physical address and contact details.
- Warranty & Design:** All units to carry a minimum 5 year warranty under normal office environment conditions. The specifications as contained in this document are the minimum NPA requirements. Vendor to take design responsibility & ensure correct specifications.



FURNITURE SPECIFICATIONS



Draft

Executive Cupboard with / without Glass Doors

Code (with doors): NPA-FC-EC-DOOR
Code (without doors): NPA-FC-EC-OPEN

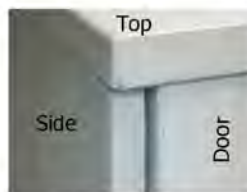

FINISH



Vancouver Maple CDL



CAD Furniture Symbol:

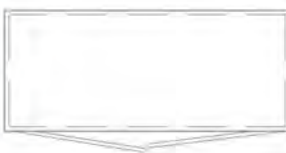

CODE Description

FC	EC	DOOR/OPEN
CATEGORY	DESCRIPTION	WITH / WITHOUT DOORS

Barcode:

NPA issued barcode to be fixed to top of unit before delivery to site.

NOTE:

May ONLY be used for Executive applications.

TECHNICAL INFORMATION

- Dimensions:** 1140mm wide x 600mm deep x 1500mm high.
- Carcass:** Top 22mm & 3x shelves 32mm high-density particle board with surface of 0.6mm Decon CDL, all other components 16mm high-density particle board with surface of Melawood Shelf heights to be adjustable at approx 50mm vertical spacings. All parts not exposed / visible to get 0.2mm brown backer.
- Glass:** Glass door to SABS (and any other safety) requirements.
- Finish:** Vancouver Maple CDL with 2mm maple finish flat edge high impact edging with straight joints.
- Iron Mongery:** High strength 110degree 8mm cranked chrome hinges, each door to be hung with 3 hinges; top, centre and bottom.
Handles to be SaddleWood arch handles of 110mm length (Gelmar or equal or similar).
- Locks:** Internal locking mechanism to lock at bottom and top of cupboard. See images above.
- Supplier:** Plasticised sticker fixed out of sight, stating: Supplier, physical address and contact details.
- Warranty & Design:** All units to carry a minimum 5 year warranty under normal office environment conditions. The specifications as contained in this document are the minimum NPA requirements. Vendor to take design responsibility & ensure correct specifications.

Open



Door



FURNITURE SPECIFICATIONS



EXECUTIVE LIBRARY CUPBOARD ^{Draft}

Code: FC-LC-EX

Executive Library Cupboard



FINISH



Vancouver Maple Veneer

CAD Furniture Symbol:

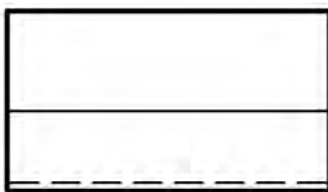

CODE Description

FC	LC	EX
CATEGORY	DESCRIPTION	TYPE

Barcode:

NPA issued barcode to be on top of cabinet before delivery to site.

NOTE:

May ONLY be used for Executive applications. Level 14 & UP

TECHNICAL INFORMATION

Dimensions:	Botom unit: 1125w x 630d x 752mm high. Top unit: 1125w x 350d x 1170mm high
Cabinet top:	Substrate from high-density particle board, Top: 32mm with front 45 degree positive chamfer and sides staright edge 2,5mm solid maple edging. All other components 16mm. All with 0,7mm Vancouver Maple veneer surface. All parts not exposed / visible to get 0.2mm brown backer.
Edging:	Front edge of top : Solid maple positive chamfer; Other to be 2,5mm solid Vancouver Maple edging with straight joints.
Finish:	VENEER: First Coat sanding sealer, Fill board and sand down, Second Coat sanding sealer, Sand down, Apply colour if applicable, 3x Coats "Chemspec" or similar or equal product thinners based High Gloss varnish with A-C catalyst, sprayed on. Allow to dry between coats.
Shelf, Doors,	BLACK: Spray paint Satin Gloss Duco, Black.
Drawers:	Internal maple veneer shelves to be adjustable on clear plastic adjusters with steel pin . Doors to have safety glass Drawers to have solid bases.
Ironmongery:	Routed finger groove in top of drawers and left "hatch"-type door. Black door to get D-typr pull handle saddlewood. High strength 110degree 8mm cranked chrome hinges, each door to be hung with 2 hinges. Hatch-type maple door to have chromed stay mechanism (open at top to flip downwards). Drawers on full extension ball bearing runners.
Supplier:	Plasticised sticker fixed out of sight, stating: Supplier, physical address and contact details.
Warranty & Design:	All units to carry a minimum 5 year warranty under normal office environment conditions. The specifications as contained in this document are the minimum NPA requirements. Vendor to take design responsibility & ensure correct specifications.



FURNITURE SPECIFICATIONS



Draft

EXECUTIVE MOBILE PEDESTAL Code: NPA-FC-MP-EX



FINISH



Vancouver Maple Veneer

CAD Furniture Symbol:



CODE Description

FC	MP	EX
CATEGORY	DESCRIPTION	TYPE

Barcode:

NPA issued barcode to be on top of cabinet before delivery to site.

NOTE:

May ONLY be used for Executive applications. Level 14 & UP

TECHNICAL INFORMATION

- Dimensions:** 410 wide x 600 deep x 565 high (incl castors).
- Carcass:** Substrate from 16mm high-density particle board with 0,7mm Vancouver Maple veneer surface. All parts not exposed / visible to get 0.2mm brown backer.
- Edging:** 2,5mm solid Vancouver Maple edging with straight joints.
- Finishes:** VENEER: First Coat sanding sealer, Fill board and sand down, Second Coat sanding sealer, Sand down, Apply colour if applicable, 3x Coats "Chemspec" or similar or equal product thinners based High Gloss varnish with A-C catalyst, sprayed on. Allow to dry between coats.
BLACK: Spray paint Satin sheen Duco, Black.
- Handles:** Routed finger groove in top of doors.
- Drawers:** Three -drawer pedestal fitted with 1x Pencil drawer with suspended tray, 1 x normal drawer, 1 x deep filer drawer fitted with cradle to accommodate either foolscap or A4 files.
- Locks:** Independent central locking mechanism. 2 keys.
- Wheels:** 40mm Nylon double acting castors to u/s. Runners to be metal with nylon rollers (Blum or similar).
- Supplier:** Plasticised sticker fixed out of sight, stating: Supplier, physical address and contact details.
- Warranty & Design:** All units to carry a minimum 5 year warranty under normal office environment conditions. The specifications as contained in this document are the minimum NPA requirements. Vendor to take design responsibility & ensure correct specifications.



FURNITURE SPECIFICATIONS



Draft

EXECUTIVE SERVER Code: NPA-FC-S-EX

Executive Server



Executive server with internal shelf & 3 internal drawers

FINISH



Vancouver Maple Veneer

CAD Furniture Symbol:

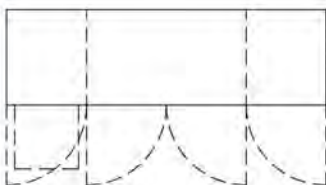

CODE Description

FC	S	EX
CATEGORY	DESCRIPTION	TYPE

Barcode:

NPA issued barcode to be on top of cabinet before delivery to site.

NOTE:

May ONLY be used for Executive applications. Level 14 & UP

TECHNICAL INFORMATION

- Dimensions:** 2000 x 600 x 920mm high.
- Counter top:** Substrate from high-density particle board, Top: 32mm, all other components 16mm. All with 0,7mm Vancouver Maple veneer surface. All parts not exposed / visible to get 0.2mm brown backer.
- Edging:** 2,5mm solid Vancouver Maple edging with straight joints.
- Finish:** VENEER: First Coat sanding sealer, Fill board and sand down, Second Coat sanding sealer, Sand down, Apply colour if applicable, 3x Coats "Chemspec" or similar or equal product thinners based High Gloss varnish with A-C catalyst, sprayed on. Allow to dry between coats.
BLACK: Spray paint High Gloss Duco, Black.
- Handles:** Routed finger groove in top of doors.
- Shelf:** Internal shelf from 1mm steel sheet - powder coated matt black for finish. Adjustable at approx 50mm vertical spacings. Edges bent to form 25mm square.
- Iron mongery:** High strength 110degree 8mm cranked chrome hinges, each door to be hung with 2 hinges.
- Drawers:** 3x internal solid sheetmetal drawers behind left door. Drawers to have 3 part telescopic drawer extension mechanism with steel 'Accuride' type bearings to allow 110% extension with 'Anti-Tilt' function.
- Supplier:** Plasticised sticker fixed out of sight, stating: Supplier, physical address and contact details.
- Warranty & Design:** All units to carry a minimum 5 year warranty under normal office environment conditions. The specifications as contained in this document are the minimum NPA requirements. Vendor to take design responsibility & ensure correct specifications.



FURNITURE SPECIFICATIONS



Draft

EXECUTIVE TELEPHONE PEDESTAL Code: NPA-FC-TP-EX



Executive mobile telephone Pedestal

FINISH



Vancouver Maple Veneer

CODE Description

FC	TP	EX
CATEGORY	DESCRIPTION	TYPE

Barcode:

NPA issued barcode to be on top of cabinet before delivery to site.

NOTE:

May ONLY be used for Executive applications. Level 14 & UP

TECHNICAL DATA

DESCRIPTION: Substrate from 32mm high-density particle board, joints mitered. All sides 0,7mm Vancouver Maple veneer surface. 2,5mm solid Maple edging with straight joints.

FINISH: First Coat sanding sealer, Fill board and sand down, Second Coat sanding sealer, Sand down, Apply colour if applicable, 3x Coats "Chemspec" or similar or equal product thinners based high gloss varnish with A-C catalyst, sprayed on. Allow to dry between coats

SIZE: 400w x 600l x 550h (incl. castors)

SUPPLIER: Plasticised sticker fixed out of sight, stating supplier, physical address and contact details.

WARRANTY & DESIGN: All units to carry a minimum 5 year Warranty under normal office environment conditions. The specifications as contained in this document are the minimum NPA requirements. Vendor to take design responsibility and ensure correct specifications.



FURNITURE SPECIFICATIONS



Draft

EXECUTIVE Top Retrieval Filing Unit: Code:NPA-FC-ETR-5



1140w x 595d x 1500h
5 drawer Top Retrieval unit

FINISH



Vancouver Maple CDL



110% anti-tilt telescopic extension from steel with steel "Accurite" type bearings.



Locking mech integral part of anti-tilt mech and runner design.

CAD Furniture Symbol:



CODE Description

FC	ETR	5
CATEGORY	DESCRIPTION	NO DRAWERS

Barcode:

NPA issued barcode to be fixed to top of unit before delivery to site.



Cradle: Drop in box.



Handle Finish: Saddlewood

NOTE:

May ONLY be used for Executive applications. Level 14 & UP.

TECHNICAL INFORMATION

- Dimensions:** 1140mm wide x 595mm deep x 1500mm high.
- Frame:** Min 60 micron electrostatic epoxy powder coated precision engineered steel frame pre-cut & pre-punched for all fittings. Metal frame - not 'Aesthetic' carcass - to carry weight and stress loading of entire filing unit. Min 25mm high levelling device from 10mm dia steel bolt to each steel upright on each corner with injection moulded plastic feet to protect carpet. Metal base and top section. Frame strengthening as required.
- Drawers:** 3 part telescopic drawer extension mechanism with steel 'Accuride' type bearings to allow 110% extension with 'Anti-Tilt' function. Loading weight: min 93kg's per draw. Only 1 of 5 draws open at a time. Cradle type drawers from epoxy powder coated 0.6mm steel sheet to support 'Optiplan' or similar or equal type drop in box holder. Pop riveted / spot welded to frame.
- Cladding:** All aesthetic cladding from high-density particle board, top (non structural) 22mm with surface of 0.6mm Decon CDL, all other components 16mm high-density particle board with surface of Melawood. All parts not exposed / visible to get 0.2mm brown backer. Lock strip and kick plate: Spray paint black Duco.
- Finish:** Vancouver Maple CDL with 2mm maple finish flat edge high impact edging with straight joints.
- Ironmongery:** SaddleWood arch handles of 110mm length, 2/drawer to ensure rugged operability (Gelmar or similar or equal).
- Locks:** Internal central locking mechanism with removable barrel and masterkey designed as integral part of anti-tilt and drawer runner with 2 keys. Lock strip at top. Lock position centre of unit width.
- Supplier:** Plasticised sticker fixed out of sight, stating: Supplier, physical address and contact details.
- Warranty & Design:** Unit to be supplied with 8 year warranty under normal office usage conditions. The specifications as contained in this document are the minimum NPA requirements. Vendor to take design responsibility & ensure correct specifications



FURNITURE SPECIFICATIONS



Draft

Top Retrieval Filing Cupboard Code:NPA-FC-TR-2



900w x 650d x 752h
2 drawer Top Retrieval unit

FINISH



Vancouver Maple CDL



110% anti-tilt telescopic extension from steel with steel "Accurite" type bearings.



Locking mech integral part of anti-tilt mech and runner design.

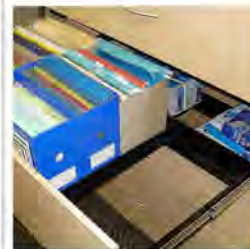

Cradle: Drop in box.



Handle Finish: SaddleWood

CAD Furniture Symbol:



CODE Description

FC	TR	2
CATEGORY	DESCRIPTION	NO DRAWERS

Barcode:

NPA issued barcode to be fixed to top of unit before delivery to site.

NOTE:

FC- -2 may ONLY be used for Executive applications. Level 14 & UP.

TECHNICAL INFORMATION

Dimensions:	Top: 900 x 650 x 752mm AFFL. Drawer System: 880w x 630d x 680h. 25mm adjustable height.
Frame:	Min 60 micron electrostatic epoxy powder coated precision engineered steel frame pre-cut & pre-punched for all fittings. Frame - not 'Aesthetic' carcass - to carry weight and stress loading of entire filing unit. Min 25mm high levelling device from 10mm dia steel bolt to each steel upright on each corner with injection moulded plastic feet to protect carpet. Metal base and top section. Frame strengthening as required.
Drawers:	3 part telescopic drawer extension mechanism with steel 'Accuride' type bearings to allow 110% extension with 'Anti-Tilt' function. Loading weight: min 93kg's per draw. Only 1 of 2 draws open at a time. Cradel type drawers from black epoxy powder coated 0.6mm steel sheet to support 'Optiplan' or similar or equal type drop in box holder. Pop riveted / spot welded to frame.
Cladding:	All aesthetic cladding from high-density particle board, top (non structural) 32mm with surface of 0.6mm Deccon CDL, all other components 16mm high-density particle board with surface of Melawood. 32mm shadowline at bottom. All parts not exposed / visible to get 0.2mm brown backer. Lock strip and kick plate: Spray paint black Duco.
Finish:	Vancouver Maple CDL with 2mm maple finish flat edge high impact edging with straight joints.
Iron Mongery:	Saddlewood arch handles of 110mm length for opening, 2/drawer to ensure rugged operability (Gelmar or equal or similar).
Locks:	Internal central locking mechanism with removable barrel and masterkey designed as integral part of anti-tilt and drawer runner with 3 keys. Lock strip at top. Lock position centrae of unit width.
Supplier:	Plasticised sticker fixed out of sight, stating: Supplier, physical address and contact details.
Warranty & Design:	Unit to be supplied with 8 year warranty under normal office usage conditions. The specifications as contained in this document are the minimum NPA requirements. Vendor to take design responsibility & ensure correct specifications



FURNITURE SPECIFICATIONS



EXECUTIVE TOP RETRIEVAL FILING UNIT: Code:NPA-FC-ETR-2

Draft



1140w x 595d x 752h
5 drawer Top Retrieval unit

FINISH



Vancouver Maple CDL



110% anti-tilt telescopic extension from steel with steel "Accurite" type bearings.



Locking mech integral part of anti-tilt mech and runner design.

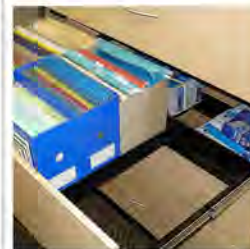

Cradle: Drop in box.



Handle Finish: Saddlewood

CAD Furniture Symbol:



CODE Description

FC	ETR	2
CATEGORY	DESCRIPTION	NO DRAWERS

Barcode:

NPA issued barcode to be fixed to top of unit before delivery to site.

NOTE:

FC- -2 may ONLY be used for Executive applications. Level 14 & UP

TECHNICAL INFORMATION

- Dimensions:** Top: 1140w x 575d @ 752mm AFFL. Drawer System: 1120w x 575d x 680h. 25mm adjustable height.
- Frame:** Min 60 micron electrostatic epoxy powder coated precision engineered steel frame pre-cut & pre-punched for all fittings. Metal frame - not 'Aesthetic' carcass - to carry weight and stress loading of entire filing unit. Min 25mm high levelling device from 10mm dia steel bolt to each steel upright on each corner with injection moulded plastic feet to protect carpet. Metal base and top section. Frame strengthening as required.
- Drawers:** 3 part telescopic drawer extension mechanism with steel 'Accuride' type bearings to allow 110% extension with 'Anti-Tilt' function. Loading weight: min 93kg's per draw. Only 1 of 5 draws open at a time. Cradle type drawers from epoxy powder coated 0.6mm steel sheet to support 'Optiplan' or similar or equal type drop in box holder. Pop riveted / spot welded to frame.
- Cladding:** All aesthetic cladding from high-density particle board, top (non structural) 32mm with surface of 0.6mm Decon CDL, all other components 16mm high-density particle board with surface of Melawood. All parts not exposed / visible to get 0.2mm brown backer. Lock strip and kick plate: Spray paint black Duco.
- Finish:** Vancouver Maple CDL with 2mm maple finish flat edge high impact edging with straight joints.
- Ironmongery:** SaddleWood arch handles of 110mm length, 2/drawer to ensure rugged operability (Gelmor or similar or equal).
- Locks:** Internal central locking mechanism with removable barrel and masterkey designed as integral part of anti-tilt and drawer runner with 2 keys. Lock strip at top. Lock position centre of unit width.
- Supplier:** Plasticised sticker fixed out of sight, stating: Supplier, physical address and contact details.
- Warranty & Design:** Unit to be supplied with 8 year warranty under normal office usage conditions. The specifications as contained in this document are the minimum NPA requirements. Vendor to take design responsibility & ensure correct specifications



FURNITURE SPECIFICATIONS



Draft

Fixed Pedestal: Executive PA Code: NPA-FC-EFP



Fixed pedestal as part of Exec Support WS

FINISH



Vancouver Maple CDL



110% anti-tilt telescopic extension from steel with steel "Accurite" type bearings.



Locking mech integral part of anti-tilt mech and runner design.



Cradle: Drop in box.



Handle Finish: Saddlewood

CAD Furniture Symbol:

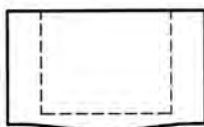

CODE Description

FC	EFP
CATEGORY	DESCRIPTION

Barcode:

NPA issued barcode to be fixed to top of unit before delivery to site.

NOTE:

May ONLY be used for Executive applications.

TECHNICAL INFORMATION

- Dimensions:** 760mm wide x 595mm deep x 752mm high.
- Frame:** Min 60 micron electrostatic epoxy powder coated precision engineered steel frame pre-cut & pre-punched for all fittings. Metal frame - not 'Aesthetic' carcass - to carry weight and stress loading of entire filing unit. Min 25mm high levelling device from 10mm dia steel bolt to each steel upright on each corner with injection moulded plastic feet to protect carpet. Metal base and top section. Frame strengthening as required.
- Drawers:** 3 part telescopic drawer extension mechanism with steel 'Accuride' type bearings to allow 110% extension with 'Anti-Tilt' function. Loading weight: min 93kg's per draw. Top drawer to have fixed sheetmetal tray, 2x bottom drawers: Cradle type, epoxy powder coated 0.6mm steel sheet to support 'Optiplan' or similar or equal type drop in box holder, pop riveted / spot welded to frame.
- Cladding:** All aesthetic cladding from high-density particle board, top (non structural) 32mm with surface of 0.6mm Decon CDL, all other components 16mm high-density particle board with surface of 0.35mm Decon CDL. All parts not exposed / visible to get 0.2mm brown backer. Vancouver Maple CDL with 2mm maple finish flat edge high impact edging with straight joints.
- Finish:** SaddleWood arch handles of 110mm length for opening (Gelmar or equal or similar).
- Iron Mongery:** Internal central locking mechanism with removable barrel and masterkey designed as integral part of anti-tilt and drawer runner with 2 keys.
- Locks:** Plasticised sticker fixed out of sight, stating: Supplier, physical address and contact details.
- Supplier:** Unit to be supplied with 8 year warranty under normal office usage conditions. The specifications as contained in this document are the minimum NPA requirements. Vendor to take design responsibility & ensure correct specifications
- Warranty & Design:**



FURNITURE SPECIFICATIONS



Draft

FIXED PEDESTAL Code: NPA-FC-FP

Typical Fixed pedestal



FINISH



Vancouver Maple CDL

CAD Furniture Symbol:

CODE Description

FC	FP
CATEGORY	DESCRIPTION

Barcode:

NPA issued barcode to be on top of cabinet before delivery to site.

NOTE:

May NOT be used for Executive applications.

FIXED PEDESTAL

- Dimensions:** 420 wide x 600 deep x 752 high(incl. top)
- Carcass:** Top 32mm high-density particle board with surface of 0.6mm Decon CDL, all other components 16mm high-density particle board with surface of Melawood. All parts not exposed / visible to get 0.2mm brown backer.
- Drawers:** Three -drawer pedestal fitted with 1x Pencil drawer with suspended tray, 1 x normal drawer, 1 x deep filer drawer fitted with cradle to accommodate either foolscap or A4 files.. Front to have Saddlewood arch handles of 110mm (Gelmar or equal or similar) for opening.
- Finishes:** Vancouver Maple CDL with 2mm maple finish flat edge high impact edging with straight joints.
- Locks:** Independent central locking mechanism. 2 keys.
- Supplier:** Plasticised sticker fixed out of sight, stating: Supplier, physical address and contact details.
- Warranty & Design:** All units to carry a minimum 5 year Warranty under normal office environment conditions. The specifications as contained in this document are the minimum NPA requirements. Vendor to take design responsibility & ensure correct specifications.



FURNITURE SPECIFICATIONS



Draft

Mobile PEDESTAL Code: NPA-FC-MP

Typical Mobile pedestal



FINISH



Vancouver Maple CDL

CAD Furniture Symbol:

CODE Description

FC MP

CATEGORY

DESCRIPTION

Barcode:

NPA issued barcode to be on top of cabinet before delivery to site.

NOTE:

May NOT be used for Executive applications.

MOBILE PEDESTAL

- Dimensions:** 420 wide x 600 deep x 640 high.
- Carcass:** Top 16mm high-density particle board with surface of Melawood, all other components 16mm high-density particle board with surface of Melawood. All parts not exposed / visible to get 0.2mm brown backer.
- Drawers:** Three -drawer pedestal fitted with 1x Pencil drawer with suspended tray, 1 x normal drawer, 1 x deep filer drawer fitted with cradle to accommodate either foolscap or A4 files. Saddlewood arch handles of 110mm (Gelmar or equal or similar) for opening.
- Finishes:** Vancouver Maple CDL with 2mm maple finish flat edge high impact edging with straight joints.
- Locks:** Independent central locking mechanism. 2 keys.
- Wheels:** 40mm Nylon double acting castors to u/s. Runners to be metal with nylon rollers (Blum or similar).
- Supplier:** Plasticised sticker fixed out of sight, stating: Supplier, physical address and contact details.
- Warranty & Design:** All units to carry a minimum 5 year warranty under normal office environment conditions. The specifications as contained in this document are the minimum NPA requirements. Vendor to take design responsibility & ensure correct specifications.



FURNITURE SPECIFICATIONS



Draft

PEDENZA Code: NPA-FC-PE

Typical Pedenza



FINISH



Vancouver Maple CDL

CAD Furniture Symbol:

CODE Description

FC	PE
CATEGORY	DESCRIPTION

Barcode:

NPA issued barcode to be on top of cabinet before delivery to site.

NOTE:

May NOT be used for Executive applications.

TECHNICAL DATA

- Dimensions:** 1150 wide x 600 deep x 752 high (Incl top).
- Carcass:** Top 32mm with surface of 0.6mm Decon CDL, all other components 16mm high-density particle board with surface of Melawood. Cupboard to contain 1 internal shelf from 1mm steel sheet - powder coated matt black for finish. Shelf height to be adjustable at approx 50mm vertical spacings. Edges bents to form 25mm square. All parts not exposed / visible to get 0.2mm brown backer.
- Door:** Horizontal roller shutter door, colour Saddlewood. Saddlewood arch handle of 110mm (Gelmar or equal or similar) for opening.
- Drawers:** Three drawers fitted with 1x pencil drawer with suspended tray, 1x normal drawer, 1x deep filer drawer fitted with cradle to accommodate either foolscap or A4 files. front to have SaddleWod arch handles of 110m (Gelmar)
- Finishes:** Vancouver Maple CDL with 2mm maple finish flat edge high impact edging.
- Locks:** Independent central locking mechanism. 2 keys.
- Supplier:** Plasticised sticker fixed out of sight, stating: Supplier, physical address and contact details.
- Warranty & Design:** All units to carry a minimum 5 year warranty under normal office environment conditions.
The specifications as contained in this document are the minimum NPA requirements. Vendor to take design responsibility & ensure correct specifications.



FURNITURE SPECIFICATIONS



Draft

SERVER Code: NPA-FC-S

Server

Vancouver Maple CDL counter top, doors & carcass (white inners)



Server with internal shelf & 3 internal drawers

32mm Flat edge from 2.5mm thick High Impact Maple PVC

FINISH



Vancouver Maple CDL

CAD Furniture Symbol:

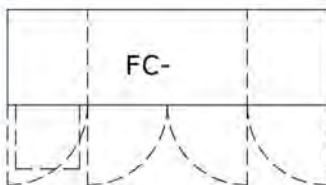

CODE Description

FC S

CATEGORY
DESCRIPTION

Barcode:

NPA issued barcode to be on top of cabinet before delivery to site.

TECHNICAL INFORMATION

- Dimensions:** 2000 x600 x 920mm high.
- Counter top:** 32mm thick worktop substrate from high-density particle board with surface of 0.6m Decon CDL. All parts not exposed / visible to get 0.2mm brown backer.
- Edging:** 2,5mm High Impact PVC Maple edging with overlapping straight joints sanded smooth.
- Finish:** Carcass, Counter Top and drawer faces from Vancouver Maple CDL. Shelves white Decon CDL. Shelf heights to be adjustable at approx 25mm vertical spacings over full height of vertical boards.
- Sides & Doors:** Sides and Doors from be 16mm HD particle board Vancouver Maple. Each door to be hung with 3 Roco hinges. Recessed 50mm back from counter top front edge. All doors equal width with Max 5mm gaps.
- Iron mongery:** Handles to be SaddleWood finished arch handles of 110mm length (Gelmar or equal or similar).
- Drawers:** Runners to be 450mm Roco Excel Slow motion. Draw Face from Vancouver Maple Decon CDL. Saddlewood Handles mounted Horizontally.
- Supplier:**
- Warranty & Design:** Platicised sticker on rear face of unit at top clearing indicating name of supplier, date of manufacture and contact details. All units to carry a minimum 5 year warranty under normal office environment conditions. The specifications as contained in this document are the minimum NPA requirements. Vendor to take design responsibility & ensure correct specifications.



FURNITURE SPECIFICATIONS



Draft

Standard Office Cupboard Code: NPA-FC-3-SC

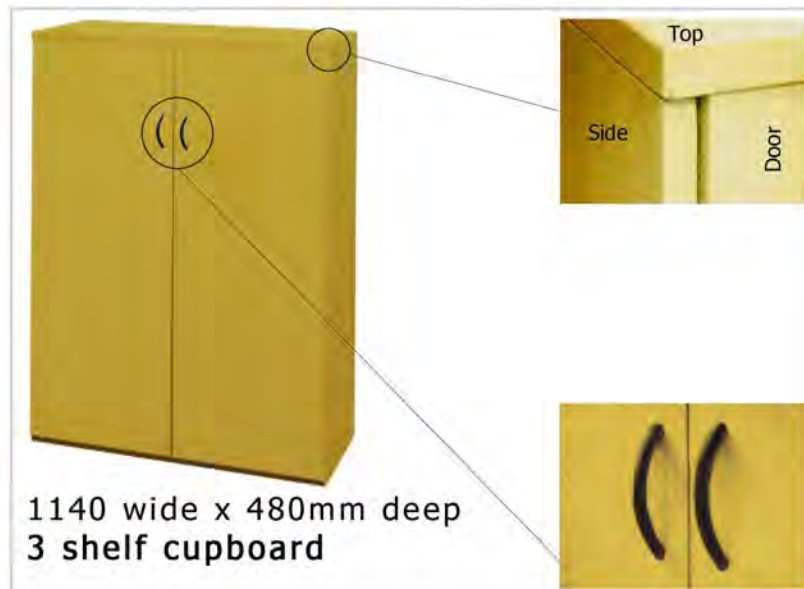

FINISH



Vancouver Maple CDL

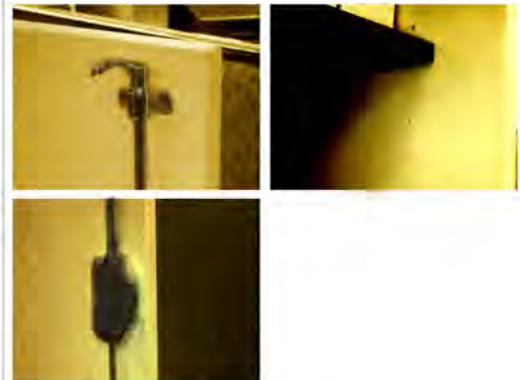

CAD Furniture Symbol:



CODE Description

FC	3	SC
CATEGORY	SHELF	DESCRIPTION

Barcode:

NPA issued barcode to be fixed to top of unit before delivery to site.

TECHNICAL INFORMATION

- Dimensions:** 1140mm wide x 480mm deep x 1500mm high.
- Carcass:** Top 22mm high-density particle board with surface of 0.6mm Decon CDL, all other components 16mm high-density particle board with surface of Melawood. Cupboard to contain 3 internal shelves from 1mm steel sheet - powder coated matt black for finish. Shelf heights to be adjustable at approx 50mm vertical spacings. Edges bent to form 25mm square. All parts not exposed / visible to get 0.2mm brown backer.
- Finish:** Vancouver Maple CDL with 2mm maple finish flat edge high impact edging with straight joints.
- Iron Mongery:** High strength 110degree 8mm cranked chrome hinges, each door to be hung with 3 hinges; top, centre and bottom. Handles to be SaddleWood arch handles of 110mm length (Gelmar or equal or similar). Internal locking mechanism to lock at bottom and top of cupboard. See images above.
- Supplier:** Plasticised sticker fixed out of sight, stating: Supplier, physical address and contact details.
- Warranty & Design:** All units to carry a minimum 5 year warranty under normal office environment conditions. The specifications as contained in this document are the minimum NPA requirements. Vendor to take design responsibility & ensure correct specifications.



FURNITURE SPECIFICATIONS



Standard Open Book Shelf Code: NPA-FC-4-OB

Draft



1140 wide x 480mm deep
open book shelf

FINISH



Vancouver Maple CDL

CAD Furniture Symbol:



CODE Description

FC	4	OB
CATEGORY	SHELF	DESCRIPTION

Barcode:

NPA issued barcode to be fixed to top of unit before delivery to site.

NOTE:

NOT to be used for Executive applications.

TECHNICAL INFORMATION

- Dimensions:** 1140mm wide x 480mm deep x 1500mm high.
- Carcass:** Top 22mm & shelves 32mm high-density particle board with surface of 0.6mm Decon CDL, all other components 16mm high-density particle board with surface of Melawood. Shelf heights to be adjustable at approx 50mm vertical spacings. All parts not exposed / visible to get 0.2mm brown backer.
- Finish:** Vancouver Maple CDL with 2mm maple finish flat edge high impact edging with straight joints.
- Supplier:** Plasticised sticker fixed out of sight, stating: Supplier, physical address and contact details.
- Warranty & Design:** All units to carry a minimum 5 year warranty under normal office environment conditions. The specifications as contained in this document are the minimum NPA requirements. Vendor to take design responsibility & ensure correct specifications.



FURNITURE SPECIFICATIONS



Draft

Top Retrieval Filing Cupboard Code: NPA-FC-2-TR



900w x 650d x 752h
2 drawer Top Retrieval unit

FINISH



Vancouver Maple CDL



110% anti-tilt telescopic extension from steel with steel "Accurite" type bearings.



Locking mech integral part of anti-tilt mech and runner design.

CAD Furniture Symbol:



CODE Description

FC	TR	2
CATEGORY	DESCRIPTION	NO DRAWERS

Barcode:

NPA issued barcode to be fixed to top of unit before delivery to site.



Cradle: Drop in box.



Handle Finish: SaddleWood

NOTE:

NOT to be used for Executive applications.

TECHNICAL INFORMATION

Dimensions:	Top: 900 x 650 x 752mm AFFL. Drawer System: 880w x 630d x 680h. 25mm adjustable height.
Frame:	Min 60 micron electrostatic epoxy powder coated precision engineered steel frame pre-cut & pre-punched for all fittings. Frame - not 'Aesthetic' carcass - to carry weight and stress loading of entire filing unit. Min 25mm high levelling device from 10mm dia steel bolt to each steel upright on each corner with injection moulded plastic feet to protect carpet. Metal base and top section. Frame strengthening as required.
Drawers:	3 part telescopic drawer extension mechanism with steel 'Accuride' type bearings to allow 110% extension with 'Anti-Tilt' function. Loading weight: min 93kg's per draw. Only 1 of 2 draws open at a time. Cradel type drawers from black epoxy powder coated 0.6mm steel sheet to support 'Optiplan' or similar or equal type drop in box holder. Pop riveted / spot welded to frame.
Cladding:	All aesthetic cladding from high-density particle board, top (non structural) 32mm with surface of 0.6mm Deccon CDL, all other components 16mm high-density particle board with surface of Melawood. 32mm shadowline at bottom. All parts not exposed / visible to get 0.2mm brown backer.
Finish:	Vancouver Maple CDL with 2mm maple finish flat edge high impact edging with straight joints.
Iron Mongery:	Saddlewood arch handles of 110mm length for opening, 2/drawer to ensure rugged operability (Gelmar or equal or similar).
Locks:	Internal central locking mechanism with removable barrel and masterkey designed as integral part of anti-tilt and drawer runner with 3 keys. Lock strip at top. Lock position centrae of unit width.
Supplier:	Plasticised sticker fixed out of sight, stating: Supplier, physical address and contact details.
Warranty & Design:	Unit to be supplied with 8 year warranty under normal office usage conditions. The specifications as contained in this document are the minimum NPA requirements. Vendor to take design responsibility & ensure correct specifications



FURNITURE SPECIFICATIONS



Draft

Top Retrieval Filing Unit Code: NPA-FC-5-TR

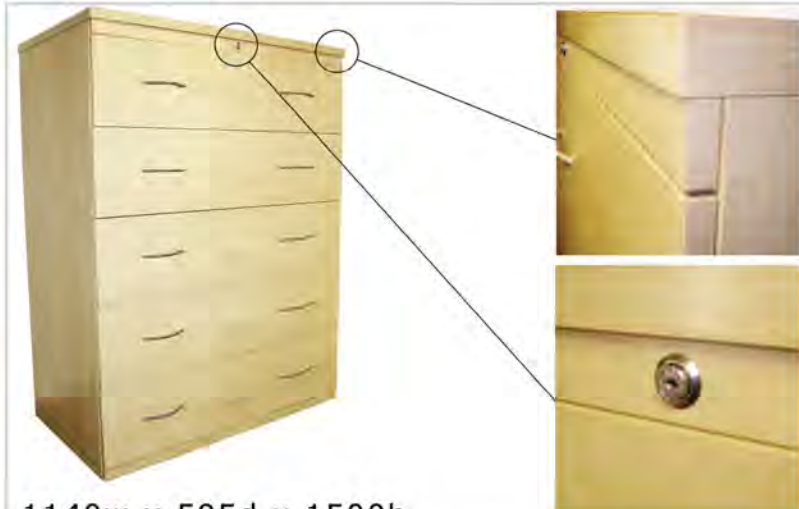

1140w x 595d x 1500h
5 drawer Top Retrieval unit

FINISH



Vancouver Maple CDL



110% anti-tilt telescopic extension from steel with steel "Accurite" type bearings.



Locking mech integral part of anti-tilt mech and runner design.



Cradle: Drop in box.



Handle Finish: Saddlewood

CAD Furniture Symbol:



CODE Description

FC	TR	5
CATEGORY	DESCRIPTION	NO DRAWERS

Barcode:

NPA issued barcode to be fixed to top of unit before delivery to site.

NOTE:

Not to be used for Executive applications.

TECHNICAL INFORMATION

Dimensions:	1140mm wide x 595mm deep x 1500mm high.
Frame:	Min 60 micron electrostatic epoxy powder coated precision engineered steel frame pre-cut & pre-punched for all fittings. Metal frame - not 'Aesthetic' carcass - to carry weight and stress loading of entire filing unit. Min 25mm high levelling device from 10mm dia steel bolt to each steel upright on each corner with injection moulded plastic feet to protect carpet. Metal base and top section. Frame strengthening as required.
Drawers:	3 part telescopic drawer extension mechanism with steel 'Accuride' type bearings to allow 110% extension with 'Anti-Tilt' function. Loading weight: min 93kg's per draw. Only 1 of 5 draws open at a time. Cradle type drawers from epoxy powder coated 0.6mm steel sheet to support 'Optiplan' or similar or equal type drop in box holder. Pop riveted / spot welded to frame.
Cladding:	All aesthetic cladding from high-density particle board, top (non structural) 22mm with surface of 0.6mm Decon CDL, all other components 16mm high-density particle board with surface of Melawood. 32mm shadowline at bottom. All parts not exposed / visible to get 0.2mm brown backer.
Finish:	Vancouver Maple CDL with 2mm maple finish flat edge high impact edging with straight joints.
Iron Mongery:	SaddleWood arch handles of 110mm length for opening, 2/drawer to ensure rugged operability (Gelmar or equal or similar).
Locks:	Internal central locking mechanism with removable barrel and masterkey designed as integral part of anti-tilt and drawer runner with 2 keys. Lock strip at top. Lock position centre of unit width.
Warranty & Design:	Plasticised sticker fixed out of sight, stating: Supplier, physical address and contact details. Unit to be supplied with 8 year warranty under normal office usage conditions. The specifications as contained in this document are the minimum NPA requirements. Vendor to take design responsibility & ensure correct specifications



OFFICE ACCESSORIES



Draft

PIN BOARDS: 1200 x 1000 BOARD Code: NPA-PB-1200-1000



MANUFACTURER: PARROT PRODUCTS
or similar or equal
PRODUCT: Pin Board
PRODUCT CODE: Not Standard
SIZE: 1200 x 1000

CODE Description

PB	1200	1000
CATEGORY	WIDTH	HEIGHT

Barcode:

NPA issued barcode to be fixed to frame before delivery to site.

<http://www.parrotproducts.biz>
(Manufacturers home page)
or similar or equal

DESCRIPTION: Royal Blue felt pin board. No frame. Mounting hooks to be included. Pin board can be mounted either horizontally or vertically.

SIZE: 1200 x 1000

SUPPLIER: Plasticised sticker fixed out of sight, stating: supplier, physical address and contact details.

WARRANTY & DESIGN: All units to carry a minimum 5 year warranty under normal office environment conditions. The specifications as contained in this document are the minimum NPA requirements. Vendor to take design responsibility and ensure correct specifications.



OFFICE ACCESSORIES



Draft

PIN BOARDS: 1500 x 1200 BOARD Code: NPA-PB-1500-1200



MANUFACTURER: PARROT PRODUCTS
or similar or equal
PRODUCT: Pin Board
PRODUCT CODE: Not Standard
SIZE: 1500 x 1200

CODE Description

PB	1500	1200
CATEGORY	WIDTH	HEIGHT

Barcode:

NPA issued barcode to be fixed to frame before delivery to site.

<http://www.parrotproducts.biz>
(Manufacturers home page)
or similar or equal

DESCRIPTION: Royal Blue felt pin board. No frame. Mounting hooks to be included. Pin board can be mounted either horizontally or vertically.
SIZE: 1500 x 1200
SUPPLIER: Plasticised sticker fixed out of sight, stating: supplier, physical address and contact details.
WARRANTY & DESIGN: All units to carry a minimum 5 year warranty under normal office environment conditions. The specifications as contained in this document are the minimum NPA requirements. Vendor to take design responsibility and ensure correct specifications.



OFFICE ACCESSORIES



Draft

PIN BOARDS: 2000 x 1200 BOARD Code: NPA-PB-2000-1200



MANUFACTURER: PARROT PRODUCTS
or similar or equal
PRODUCT: Pin Board
PRODUCT CODE: Not Standard
SIZE: 2000 x 1200

CODE Description

PB	2000	1200
CATEGORY	WIDTH	HEIGHT

Barcode:

NPA issued barcode to be fixed to frame before delivery to site.

<http://www.parrotproducts.biz>
(Manufacturers home page)
or similar or equal

- DESCRIPTION:** Royal Blue felt pin board. No frame. Mounting hooks to be included. Pin board can be mounted either horizontally or vertically.
- SIZE:** 2000 x 1200
- SUPPLIER:** Plasticised sticker fixed out of sight, stating: supplier, physical address and contact details.
- WARRANTY & DESIGN:** All units to carry a minimum 5 year warranty under normal office environment conditions. The specifications as contained in this document are the minimum NPA requirements. Vendor to take design responsibility and ensure correct specifications.



OFFICE ACCESSORIES



Draft

PIN BOARDS: 900 x 600 BOARD Code: NPA-PB-900-600



MANUFACTURER: PARROT PRODUCTS
or similar or equal
PRODUCT: Pin Board
PRODUCT CODE: BD0125
SIZE: 900 x 600

CODE Description

PB	900	600
CATEGORY	WIDTH	HEIGHT

Barcode:

NPA issued barcode to be fixed to frame before delivery to site.

<http://www.parrotproducts.biz>
(Manufacturers home page)
or similar or equal

- DESCRIPTION:** Royal Blue felt pin board. No frame. Mounting hooks to be included. Pin board can be mounted either horizontally or vertically.
- SIZE:** 900 x 600
- SUPPLIER:** Plasticised sticker fixed out of sight, stating: supplier, physical address and contact details.
- WARRANTY & DESIGN:** All units to carry a minimum 5 year warranty under normal office environment conditions. The specifications as contained in this document are the minimum NPA requirements. Vendor to take design responsibility and ensure correct specifications.



OFFICE ACCESSORIES



Draft

PIN BOARDS: 900 x 900 BOARD Code: NPA-PB-900-900



MANUFACTURER: PARROT PRODUCTS
or similar or equal
PRODUCT: Pin Board
PRODUCT CODE: Not Standard
SIZE: 900 x 900

CODE Description

PB	900	900
CATEGORY	WIDTH	HEIGHT

Barcode:

NPA issued barcode to be fixed to frame before delivery to site.

<http://www.parrotproducts.biz>
(Manufacturers home page)
or similar or equal

- DESCRIPTION:** Royal Blue felt pin board. No frame. Mounting hooks to be included. Pin board can be mounted either horizontally or vertically.
- SIZE:** 900 x 900
- SUPPLIER:** Plasticised sticker fixed out of sight, stating: supplier, physical address and contact details.
- WARRANTY & DESIGN:** All units to carry a minimum 5 year warranty under normal office environment conditions. The specifications as contained in this document are the minimum NPA requirements. Vendor to take design responsibility and ensure correct specifications.



OFFICE ACCESSORIES



Draft

PULL DOWN SCREEN Code: NPA-PDS-1520-1520



MANUFACTURER: PARROT PRODUCTS
or similar or equal
PRODUCT: Pull down projector
screen
PRODUCT CODE:
SIZE: 1520 x 1520

CODE Description

PDS	1520	1520
CATEGORY	WIDTH	HEIGHT

Barcode:

NPA issued barcode to be fixed
to frame before delivery to site.

<http://www.parrotproducts.biz>
(Manufacturers home page)
or similar or equal

DESCRIPTION: Self locking white pull down projector screen with black border and black backing. Fixing brackets to be included.
SIZE: 1520 x 1520
SUPPLIER: Plasticised sticker fixed out of sight, stating: supplier, physical address and contact details.
WARRANTY & DESIGN: All units to carry a minimum 5 year warranty under normal office environment conditions. The specifications as contained in this document are the minimum NPA requirements. Vendor to take design responsibility and ensure correct specifications.



OFFICE ACCESSORIES



Draft

PULL DOWN SCREEN Code: NPA-PDS-1830-1830



MANUFACTURER: PARROT PRODUCTS
or similar or equal
PRODUCT: Pull down projector
screen
PRODUCT CODE:
SIZE: 1830 x 1830

CODE Description

PDS	1830	1830
CATEGORY	WIDTH	HEIGHT

Barcode:

NPA issued barcode to be fixed
to frame before delivery to site.

<http://www.parrotproducts.biz>
(Manufacturers home page)
or similar or equal

DESCRIPTION: Self locking white pull down projector screen with black border and black backing. Fixing brackets to be included.
SIZE: 1830 x 1830
SUPPLIER: Plasticised sticker fixed out of sight, stating: supplier, physical address and contact details.
WARRANTY & DESIGN: All units to carry a minimum 5 year warranty under normal office environment conditions. The specifications as contained in this document are the minimum NPA requirements. Vendor to take design responsibility and ensure correct specifications.



OFFICE ACCESSORIES



PULL DOWN SCREEN Code: NPA-PDS-2440-1850

Draft



MANUFACTURER: PARROT PRODUCTS
or similar or equal
PRODUCT: Pull down projector
screen
PRODUCT CODE:
SIZE: 2440 x 1850

CODE Description

PDS	2440	1850
CATEGORY	WIDTH	HEIGHT

Barcode:

NPA issued barcode to be fixed
to frame before delivery to site.

<http://www.parrotproducts.biz>
(Manufacturers home page)
or similar or equal

DESCRIPTION: Self locking white pull down projector screen with black border and black backing. Fixing brackets to be included.
SIZE: 2440 x 1850
SUPPLIER: Plasticised sticker fixed out of sight, stating: supplier, physical address and contact details.
WARRANTY & DESIGN: All units to carry a minimum 5 year warranty under normal office environment conditions. The specifications as contained in this document are the minimum NPA requirements. Vendor to take design responsibility and ensure correct specifications.



SCREEN SPECS



Draft

1200w x 1200h Screen

Code: NPA-SCREEN-F-1200-X (where X = Fabric Option)

PASSAGE (High Wear Zone)

Typical screen colour layout for open plan cluster.

Typical cable access in screen panels (only where required.)

CDS Plastics 'CMS03' 80mm Charcoal cable outlet

Location of 1200 panels shown on "FURNITURE" plan

FURNITURE PLAN

FABRIC OPTIONS

1 Solar

2 Orange

Typical Angle Bracket for screen stability to U/S desk.

Typical Extruded Frame profile with caps.

CODE Description

SCREEN	F	1200	X
CATEGORY	DESCRIPTION	SCREEN WIDTH	FABRIC FINISH

Barcode:
NPA issued barcode to be fixed to top of screen frame before delivery to site.

NOTE:
- All screens 1200mm high AFFL.

TECHNICAL DATA

- Core:** This is of a rigid construction, not being dependent on the frame for its stability.
- Frame:** 23 mm wide aluminum extrusions of suitable thickness, which is an integral part of the screen and not removable and is coated gloss charcoal with a minimum of 60 microns of powder coating. Frame edge to allow for 0, 45, 90, 135 and 180 degree joining angles.
- Connectors:** Connectors between frame section to be from extruded aluminium only and NOT plastic/rubber. FULL HEIGHT.
- Upholstery:** 6 mm thick 'pinable' foam SBX33 bonded onto the core and covered over with approved fabric, which is stapled on the edged of the core.
- Height Adjustment:** To allow for uneven floors, the screen are to be height adjustable via plastic adjusting toes having carpet gripping studs on their underside to help prevent sideways movement of the screen.
- Reticulation & Fastening:** 80mm CDS Plastics CSM03 (charcoal) for cable reticulation to be allowed for if required with plastic grommit hole edging. Location of grommit hole edge 50mm below U/S of workstation tops and 50mm from screen frame edge. Screen system to allow for fixing mechanisms/brackets to underside of workstation for stability & support.
- Supplier:** Plasticised sticker fixed out of view stating: Supplier's name, physical address and contact details
- Warranty & Design:** Unit to be supplied with MINIMUM 5 year Warranty under normal office usage conditions. The specifications as contained in this document are the minimum NPA requirements. Vendor to take design responsibility & ensure correct specifications All screens delivered to site in 100 micron clear plastic wrapping.



SCREEN SPECS



1500w x 1200h Screen

Draft

Code: NPA-SCREEN-F-1500-X (where X =Fabric Option)

PASSAGE (High Wear Zone)

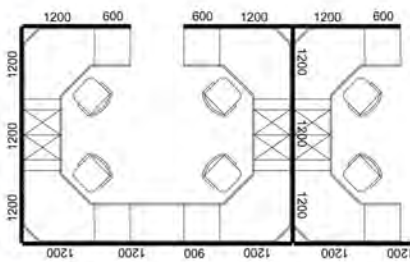

Typical screen colour layout for open plan cluster.

Typical cable access in screen panels (only where required.)



CDS Plastics 'CMS03' 80mm Charcoal cable outlet

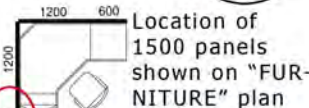

FURNITURE PLAN

FABRIC OPTIONS



1 Solar

2 Orange



Typical Angle Bracket for screen stability to U/S desk.

CODE Description

SCREEN	F	1500	X
CATEGORY	DESCRIPTION	SCREEN WIDTH	FABRIC FINISH



Typical Extruded Frame profile with caps.

Barcode:

NPA issued barcode to be fixed to top of screen frame before delivery to site.

NOTE:

- All screens 1200mm high AFFL.

TECHNICAL DATA

- Core:** This is of a rigid construction, not being dependent on the frame for its stability.
- Frame:** 23 mm wide aluminum extrusions of suitable thickness, which is an integral part of the screen and not removable and is coated gloss charcoal with a minimum of 60 microns of powder coating. Frame edge to allow for 0, 45, 90, 135 and 180 degree joining angles.
- Connectors:** Connectors between frame section to be from extruded aluminium only and NOT plastic/rubber. FULL HEIGHT.
- Upholstery:** 6 mm thick 'pinable' foam SBX33 bonded onto the core and covered over with approved fabric, which is stapled on the edged of the core.
- Height Adjustment:** To allow for uneven floors, the screen are to be height adjustable via plastic adjusting toes having carpet gripping studs on their underside to help prevent sideways movement of the screen.
- Reticulation & Fastening:** 80mm CDS Plastics CSM03 (charcoal) for cable reticulation to be allowed for if required with plastic grommit hole edging. Location of grommit hole edge 50mm below U/S of workstation tops and 50mm from screen frame edge. Screen system to allow for fixing mechanisms/brackets to underside of workstation for stability & support.
- Supplier:** Plasticised sticker fixed out of view stating: Supplier's name, physical address and contact details
- Warranty & Design:** Unit to be supplied with MINIMUM 5 year Warranty under normal office usage conditions. The specifications as contained in this document are the minimum NPA requirements. Vendor to take design responsibility & ensure correct specifications All screens delivered to site in 100 micron clear plastic wrapping.



SCREEN SPECS



Draft

900w x 1200h Screen

Code: **NPA-SCREEN-F-900-X** (where X = Fabric Option)

PASSAGE (High Wear Zone)

Typical cable access in screen panels (only where required.)

CDS Plastics 'CMS03' 80mm Charcoal cable outlet

Location of 900 panels shown on "FURNITURE" plan

FURNITURE PLAN

Typical screen colour layout for open plan cluster.

FABRIC OPTIONS

1 Solar 2 Orange

Typical Angle Bracket for screen stability to U/S desk.

Typical Extruded Frame profile with caps.

CODE Description

SCREEN	F	900	X
CATEGORY	DESCRIPTION	SCREEN WIDTH	FABRIC FINISH

Barcode:

NPA issued barcode to be fixed to top of screen frame before delivery to site.

NOTE:

- All screens 1200mm high AFFL.

TECHNICAL DATA

- Core:** This is of a rigid construction, not being dependent on the frame for its stability.
- Frame:** 23 mm wide aluminum extrusions of suitable thickness, which is an integral part of the screen and not removable and is coated gloss charcoal with a minimum of 60 microns of powder coating. Frame edge to allow for 0, 45, 90, 135 and 180 degree joining angles.
- Connectors:** Connectors between frame section to be from extruded aluminium only and NOT plastic/rubber. FULL HEIGHT.
- Upholstery:** 6 mm thick 'pinable' foam SBX33 bonded onto the core and covered over with approved fabric, which is stapled on the edged of the core.
- Height Adjustment:** To allow for uneven floors, the screen are to be height adjustable via plastic adjusting toes having carpet gripping studs on their underside to help prevent sideways movement of the screen.
- Reticulation & Fastening:** 80mm CDS Plastics CSM03 (charcoal) for cable reticulation to be allowed for if required with plastic grommit hole edging. Location of grommit hole edge 50mm below U/S of workstation tops and 50mm from screen frame edge. Screen system to allow for fixing mechanisms/brackets to underside of workstation for stability & support.
- Supplier:** Plasticised sticker fixed out of view stating: Supplier's name, physical address and contact details
- Warranty & Design:** Unit to be supplied with MINIMUM 5 year Warranty under normal office usage conditions. The specifications as contained in this document are the minimum NPA requirements. Vendor to take design responsibility & ensure correct specifications All screens delivered to site in 100 micron clear plastic wrapping.



SCREEN SPECS



Draft

1400w x 1200h Screen

Code: NPA-SCREEN-F-1400-X (where X = Fabric Option)

PASSAGE (High Wear Zone)

PASSAGE (High Wear Zone)

Typical cable access in screen panels (only where required.)

CDS Plastics 'CMS03' 80mm Charcoal cable outlet

FURNITURE PLAN

Location of 1400mm wide panels is shown on "FURNITURE" plan (see left).

FABRIC OPTIONS



1 Solar



2 Orange

Typical Angle Bracket for screen stability to U/S desk.

Typical Extruded Frame profile with caps.

CODE Description

SCREEN	F	1400	X
CATEGORY	DESCRIPTION	SCREEN WIDTH	FABRIC FINISH

Barcode:

NPA issued barcode to be fixed to top of screen frame before delivery to site.

NOTE:

- All screens 1200mm high AFFL.

TECHNICAL DATA

- Core:** This is of a rigid construction, not being dependent on the frame for its stability.
- Frame:** 23 mm wide aluminum extrusions of suitable thickness, which is an integral part of the screen and not removable and is coated gloss charcoal with a minimum of 60 microns of powder coating. Frame edge to allow for 0, 45, 90, 135 and 180 degree joining angles.
- Connectors:** Connectors between frame section to be from extruded aluminium only and NOT plastic/rubber. FULL HEIGHT.
- Upholstery:** 6 mm thick 'pinable' foam SBX33 bonded onto the core and covered over with approved fabric, which is stapled on the edged of the core.
- Height Adjustment:** To allow for uneven floors, the screen are to be height adjustable via plastic adjusting toes having carpet gripping studs on their underside to help prevent sideways movement of the screen.
- Reticulation & Fastening:** 80mm CDS Plastics CSM03 (charcoal) for cable reticulation to be allowed for if required with plastic grommit hole edging. Location of grommit hole edge 50mm below U/S of workstation tops and 50mm from screen frame edge. Screen system to allow for fixing mechanisms/brackets to underside of workstation for stability & support.
- Supplier:** Plasticised sticker fixed out of view stating: Supplier's name, physical address and contact details
- Warranty & Design:** Unit to be supplied with MINIMUM 5 year Warranty under normal office usage conditions. The specifications as contained in this document are the minimum NPA requirements. Vendor to take design responsibility & ensure correct specifications All screens delivered to site in 100 micron clear plastic wrapping.



SEATING SPECS



Draft

CONFERENCE CHAIR Code: NPA-CHAIR-CC



Black polypropylene chair with mild steel frame "aluclear" epoxy coated similar to picture

Seat fabric to be Weavers World "Vulcan Black"

CODE Description

CHAIR

CC

CATEGORY

TYPE

Barcode:

NPA issued barcode to be delivery to site.

TECHNICAL DATA

Dimensions:	Total height: 850	Seat height: 440
	Total width: 440	Seat width: 380
	Total depth: 540	Seat depth: 400
Back:	Backrest polypropylene shell, matt black	
Seat:	Seat base to be covered with polyurethane foam with a minimum thickness of 70mm glued to the nylon or suitable alternative material base shell. 50kg/cm3 foam with 250/280 neutons hardness factor. 460w x 480d x 480h.	
Frame:	Min 80 micron silver epoxy powder coated 24.5mm diameter mild steel frame - CNC machine bent and rolled. Chair to support a minimum weight of 130kg.	
Supplier:	Plasticised sticker fixed under seat stating: Supplier, physical address and contact details.	
Warranty & Design:	Unit to be supplied with MINIMUM 5 year Warranty under normal office usage conditions. The specifications as contained in this document are the minimum NPA requirements. Vendor to take design responsibility & ensure correct specifications	



SEATING SPECS



Draft

Couch - Double Seater: Code: NPA-CHAIR-CO-DS-X (where X = Fabric option)



Rectangular
Arm rests.

Double Couch

Polished
Stainless
Steel Feet

FABRIC OPTIONS



The fabric (6) is reversible and can be used both sides (Brown Figure with a Orange background)

6 Britannica



7 Smooth

CAD Symbol:



CODE Description

CHAIR	CO	DS	X
CATEGORY	DESCRIPTION	COUCH DOUBLE	FABRIC FINISH

Barcode:

NPA issued barcode to be fixed to seat base before delivery to site.

Fabric label:

Fabric label stiched to chair indicating:
*Manufacturer
*Address
*Contact no.
*e-mail address



NOTE:

TECHNICAL DATA

- Frame:** Size: As close to but not exceeding ...00mm (w) x 870mm (deep).
Designed by manufacturer to carry the minimum weight of 3x 130kg people with no creaking or give.
- Finishes:** Specified material "X" - where X is required fabric option.
- Feet:** Polished Stainless Steel feet. Wooden feet may NOT be used.
- Supplier:** Embroidered fabric label fixed to side of backrest stating: Supplier, physical address and contact details.
- Warranty:** Unit to be supplied with MINIMUM 5 year Warranty under normal office usage conditions. The specifications as contained in this document are the minimum NPA requirements. Vendor to take design responsibility & ensure correct specifications.



SEATING SPECS



Draft

Couch - Single Seater: Code: NPA-CHAIR-CO-SS-X (where X = Fabric option)



FABRIC OPTIONS



The fabric (6) is reversible and can be used both sides (Brown Figure with a Orange background)

6 Britannica



7 Smooth

CAD Symbol:



CODE Description

CHAIR	CO	SS	X
CATEGORY	DESCRIPTION	Couch Single	FABRIC FINISH

Barcode:

NPA issued barcode to be fixed to seat base before delivery to site.

Fabric label:

Fabric label stiched to chair indicating:
*Manufacturer
*Address
*Contact no.
*e-mail address



NOTE:

TECHNICAL DATA

- Frame:** Size: As close to but not exceeding 1080mm (w) x 870mm (deep).
Designed by manufacturer to carry the minimum weight of 1x 130kg people with no creaking or give.
- Finishes:** Specified material "X" - where X is required fabric option.
- Feet:** Polished Stainless Steel feet. Wooden feet may NOT be used.
- Supplier:** Embroidered fabric label fixed to side of backrest stating: Supplier, physical address and contact details.
- Warranty:** Unit to be supplied with MINIMUM 5 year Warranty under normal office usage conditions. The specifications as contained in this document are the minimum NPA requirements. Vendor to take design responsibility & ensure correct specifications.



SEATING SPECS



Draft

Executive Couch - Single Seater: Code: NPA-CHAIR-EX-SS-L



FABRIC



Genuine Leather,
Black

CAD Symbol:



CODE Description

CHAIR	EX	SS	L
CATEGORY	DESCRIPTION	Couch Single	FABRIC FINISH

Barcode:

NPA issued barcode to be fixed to seat base before delivery to site.

Fabric label:

Fabric label stiched to chair indicating:
*Manufacturer
*Address
*Contact no.
*e-mail address



NOTE:

Only for level 14 up

TECHNICAL DATA

- Frame:** Size: As close to but not exceeding 1080mm (w) x 870mm (deep).
Designed by manufacturer to carry the minimum weight of 1x 130kg people with no creaking or give.
- Finishes:** Specified material Genuine Leather Black.
- Feet:** Polished Stainless Steel feet. Wooden feet may NOT be used.
- Supplier:** Embroidered fabric label fixed to side of backrest stating: Supplier, physical address and contact details.
- Warranty:** Unit to be supplied with MINIMUM 5 year Warranty under normal office usage conditions. The specifications as contained in this document are the minimum NPA requirements. Vendor to take design responsibility & ensure correct specifications.



SEATING SPECS



Draft

Executive Couch - Double Seater: Code: NPA-CHAIR-EX-DS-L



FABRIC



Genuine Leather,
Black

CAD Symbol:



CODE Description

CHAIR	EX	DS	X
CATEGORY	DESCRIPTION	COUCH DOUBLE	FABRIC FINISH

Barcode:

NPA issued barcode to be fixed to seat base before delivery to site.

Fabric label:

Fabric label stitched to chair indicating:
*Manufacturer
*Address
*Contact no.
*e-mail address



NOTE:

Only for Level 14 up

TECHNICAL DATA

- Frame:** Size: As close to but not exceeding ...00mm (w) x 870mm (deep).
Designed by manufacturer to carry the minimum weight of 3x 130kg people with no creaking or give.
- Finishes:** Specified material Genuine Leather Black.
- Feet:** Polished Stainless Steel feet. Wooden feet may NOT be used.
- Supplier:** Embroidered fabric label fixed to side of backrest stating: Supplier, physical address and contact details.
- Warranty:** Unit to be supplied with MINIMUM 5 year Warranty under normal office usage conditions. The specifications as contained in this document are the minimum NPA requirements. Vendor to take design responsibility & ensure correct specifications.



SEATING SPECS



Draft

Executive Chair - Highback Code: NPA-CHAIR-EX-HB-L



Highback Executive Chair

Back: Min 13mm laminated plywood with 20kg/cm³ foam. SABS 640-1976 complaint. ZIP to added to edge of fabric cover.
Dims: 500W x 650H from seat

Arms: D-type moulded PU with 2.5x30mm M8 threaded bush. M6 into M6 T nut assembly. 310mm horizontal length. 250mm vertical.

Seat: Min 13mm laminated plywood with 50kg/cm³ foam with 250/280 neutons hardness factor. Dimensions: 480D x 480W

17-4 50.8 CLASS 3. Min height 450mm. Max height 540mm.

Nylon Base: 700 diameter.

Rolling Castors: 65mm diameter SABS 1292 compliant. Pin insert offset load bearing type for quick alignment in any direction.

FABRIC



Genuine Leather, Black

Fabric label:

Fabric label stitched to chair indicating:
*Manufacturer
*Address
*Contact no.
*e-mail address



Usage:

Level 14 Up.

Mechanism:

- Two Lever Syncro.

CODE Description

CHAIR	EX	HB	L
CATEGORY	DESCRIPTION	TYPE	FABRIC FINISH

Barcode:

NPA issued barcode to be fixed to seat base before delivery to site.

Castor Size:

- Wheel to measure 65mm.



TECHNICAL DATA

Backrest:

Backrest (HighBack) to be covered with polyurethane 20kg/cm³ foam SABS 640-1976 complaint with min thickness of 50mm to backrest shell. Outer backrest shell to be covered in a 6mm thick layer of low density peeling foam stapled to the periphery of the shell. 500w x 650h measured from seat. Foam to comply with DIN and SABS 640-1976 standards

Seat:

Seat base to be covered with newly developed crush free flexible foam 50kg/m³ density with a minimum thickness of 70mm glued to the base shell. 480 x 480

Arms:

Armrest to be manufactured from molded flexible nylon shaped to ensure chair fits under desk and that the arms be able to ensure a resistance free movement between seat and backrest. Arm to be constructed so as to be a full loop and not be open at the end.

Mechanisms:

Gas Cylinder and standpipe assembly to conform to BIFMA 5.1 standards and able to carry a body mass of up to 140kg. 17-4 50.8 CLASS 3. Min height 450mm. Max height 540mm. 3 Section Telescopic nylon cover in colourfast black matt finish. Two lever syncro mechanism as per indicated image. Knee tilt syncro NOT allowed.

Spider Base: & Castors

Five star reinforced (lattice construction) injection-moulded talc-free nylon in colourfast black matt finish, 700 diameter minimum. Free swivelling Castor Wheels lattice-reinforced (minimum of 8 fins) nylon type or polyurethane (for tiles areas) in colourfast black matt finish. Castor size: Min 65mm diameter of wheel.

Supplier: Warranty: & Design

Embroidered fabric label fixed to side of backrest stating: Supplier, physical address and contact details.
Unit to be supplied with MINIMUM 5 year Warranty under normal office usage conditions. The specifications as contained in this document are the minimum NPA requirements. Vendor to take design responsibility & ensure correct specifications



SEATING SPECS



Exec Sleighbase - Meeting / Visitor Draft Code: NPA-CHAIR-EX-SB-L



Back: Min 13mm laminated plywood with 20kg/cm³ foam. SABS 640-1976 complaint. ZIP to added to edge of fabric cover

Arm rest from PVC cappings as integral part of SS frame. Capping removable by M6 T nuts for replacement.

Seat: Min 13mm laminated plywood with front lip drop of min 75mm with 50kg/cm³ foam with 250/280 neutons hardness factor.

CNC Machine bent frame from tubular construction using 24.5mm diameter by 2.5mm wall thickness tubing, chrome plated.

Executive Sleighbase meeting room / visitors

FABRIC OPTIONS



Genuine Leather, Black

SUPPLIER:

Business Units:

- Executive Meeting Rooms
- Executive Visitors

CODE Description

CHAIR	EX	SB	L
CATEGORY	DESCRIPTION	TYPE	FABRIC FINISH

Barcode:

NPA issued barcode to be fixed to seat base before delivery to site.

NOTE:

Level 14 and UP

Fabric label:

Fabric label stitched to chair indicating:
*Manufacturer
*Address
*Contact no.
*e-mail address



TECHNICAL DATA

- Backrest:** Backrest to be covered with polyurethane 20kg/cm³ foam SABS 640-1976 complaint foam with min thickness of 50mm to backrest shell. Outer backrest shell to be covered in a 6mm thick layer of low density peeling foam stapled to the periphery of the shell. Backrest 500w x 650h, 600h from seat.
- Seat:** Seat base to be covered with polyurethane foam with a minimum thickness of 70mm glued to the nylon or suitable alternative material base shell. 500w x 500d, 480 from FFL
- Arms:** Armrest frame is an integral part of the chairs rolled steel frame makeup. The arm rest is covered with a molded nylon "capping" wich is removable via fastening screws for replacement if damaged. 670 from seat
- Mechanisms:** Chrome plated mild steel frame - CNC machine bent and rolled. Frame to support a minimum weight of 140kg.
- Frame:** Embroidered fabric label fixed to side of backrest stating: Supplier, physical address, date of delivery and contact details.
- Supplier:**
- Warranty & Design:** Unit to be supplied with MINIMUM 5 year Warranty under normal office usage conditions. The specifications as contained in this document are the minimum NPA requirements. Vendor to take design responsibility & ensure correct specifications.
- SiteVisit:** It is compulsory for vendor to visit site to measure existing chairs for an exact replication on new orders before manufacture.



SEATING SPECS



Draft

Chair - Highback

Code: NPA-CHAIR-HB-O-X (where X = Fabric option)

310mm

Back: Min 13mm laminated plywood with 20kg/cm³ foam. SABS 640-1976 complaint. ZIP to added to edge of fabric cover.

Arms: D-type moulded PU with 2.5x30mm M8 threaded bush. M6 into M6 T nut assembly. 310mm horizontal length. 250mm vertical.

Seat: Min 13mm laminated plywood with 50kg/cm³ foam with 250/280 neutons hardness factor

17-4 50.8 CLASS 3. Min height 450mm. Max height 540mm.

Nylon Base: 700 diameter.

Rolling Castors: 65mm diameter SABS 1292 compliant. Pin insert offset load bearing type for quick alignment in any direction.

FABRIC OPTIONS (Chair Backrest ONLY)



3 Marula



4 Sun



5 Vulcan Black

Seat Fabric: Vulcan Black

Usage:
Level 1-13

Mechanism:
- Two Lever Syncro.

CODE Description

CHAIR	HB	O	X
CATEGORY	DESCRIPTION	TYPE	FABRIC FINISH

Barcode:

NPA issued barcode to be fixed to seat base before delivery to site.

Castor Size:
- Wheel to measure 65mm.



Fabric label:

Fabric label stitched to chair indicating:
*Manufacturer
*Address
*Contact no.
*e-mail address



TECHNICAL DATA

- Backrest:** Backrest (HighBack) to be covered with polyurethane 20kg/cm³ foam SABS 640-1976 complaint foam with min thickness of 50mm to backrest shell. Outer backrest shell to be covered in a 6mm thick layer of low density peeling foam stapled to the periphery of the shell. 500w x 650h measured from seat. Foam to comply with DIN and SABS 640-1976 standards
- Seat:** Seat base to be covered with newly developed crush free flexible foam 50kg/m³ density with a minimum thickness of 70mm glued to the re base shell. 480 x 480
- Arms:** Armrest to be manufactured from molded flexible nylon shaped to ensure chair fits under desk and that the arms be able to ensure a resistance free movement between seat and backrest. Arm to be constructed so as to be a full loop and not be open at the end. Gas Cylinder and standpipe assembly to conform to BIFMA 5.1 standards and able to carry a body mass of up to 140kg. 17-4 50.8 CLASS 3. Min height 450mm. Max height 540mm. 3 Section Telescopic nylon cover in colourfast black matt finish. Two lever syncro mechanism as per indicated image. Knee tilt syncro NOT allowed.
- Mechanisms:**
- Spider Base & Castors:** Five star reinforced (lattice construction) injection-moulded talc-free nylon in colourfast back matt finish, 700 diameter minimum. Free swivelling Castor Wheels lattice-reinforced (minimum of 8 fins) nylon type or polyurethane (for tiles areas) in colourfast black matt finish. Castor size: Min 65mm diameter of physical wheel.
- Supplier:** Embroidered fabric label fixed to side of backrest stating: Supplier, physical address and contact details.
- Warranty & Design:** Unit to be supplied with MINIMUM 5 year Warranty under normal office usage conditions. The specifications as contained in this document are the minimum NPA requirements. Vendor to take design responsibility & ensure correct specifications



SEATING SPECS



Draft

PAUSE AREA CHAIR Code: NPA-CHAIR-PC-PA



Black polypropylene chair with mild steel frame "aluclear" epoxy coated similar to picture

CODE Description

CHAIR	PC	PA
CATEGORY	DESCRIPTION	TYPE

Barcode:

NPA issued barcode to be fixed to seat base before delivery to site.

TECHNICAL DATA

- Dimensions:** Total height: 850 Seat height: 440
Total width: 440 Seat width: 380
Total depth: 540 Seat depth: 400
- Seat & Back:** Seat & backrest polypropylene shell, matt black
- Frame:** Min 80 micron silver epoxy powder coated 24.5mm diameter mild steel frame - CNC machine bent and rolled. Chair to support a minimum weight of 130kg.
- Supplier:** Plasticised sticker fixed under seat stating: Supplier, physical address and contact details.
- Warranty & Design:** Unit to be supplied with MINIMUM 5 year Warranty under normal office usage conditions. The specifications as contained in this document are the minimum NPA requirements. Vendor to take design responsibility & ensure correct specifications



SEATING SPECS



Draft

VISITOR'S SLEIGHBASE CHAIR

Code: NPA-CHAIR-SB-V-X (where X = Fabric option)



Back: Min 13mm laminated plywood with 20kg/cm³ foam. SABS 640-1976 complaint. ZIP to added to edge of fabric cover.

Arm rest from PVC cappings as integral part of frame. Capping removable by M6 T nuts for replacement.

Seat: Min 13mm laminated plywood with 50kg/cm³ foam with 250/280 neutons hardness factor.

Machine bent frame from tubular construction using 24.5mm diameter by 2.5mm wall thickness mild steel tubing. Min 80 Micron micron epoxy powder.

FABRIC OPTIONS (Chair Backrest ONLY)



3 Marula



4 Sun



5 Vulcan Black

Seat Fabric: Vulcan Black

CODE Description

CHAIR	SB	V	X
CATEGORY	DESCRIPTION	TYPE	FINISH

Barcode:

NPA issued barcode to be fixed to seat base before delivery to site.

Fabric label:

Fabric label stitched to chair indicating:
*Manufacturer
*Address
*Contact no.
*e-mail address



TECHNICAL DATA

- Backrest:** Backrest (MidBack) to be covered with polyurethane 20kg/cm³ foam SABS 640-1976 complaint foam with min thickness of 50mm to backrest shell. Outer backrest shell to be covered in a 6mm thick layer of low density peeling foam stapled to the periphery of the shell. 480w x 600h, 500h from seat.
- Seat:** Seat base to be covered with polyurethane foam with a minimum thickness of 70mm glued to the nylon or suitable alternative material base shell. 50kg/cm³ foam with 250/280 neutons hardness factor. 460w x 480d x 480h
- Arms:** Armrest frame is an integral part of the chairs rolled steel frame makeup. The arm rest is covered with a molded nylon or PVC "capping" wich is removable via M6 into M6 T nut assembly fastening screws for replacement if damaged. 650 above FFL
- Frame:** Min 80 micron black epoxy powder coated 24.5mm diameter mild steel frame - CNC machine bent and rolled. Frame to support a minimum weight of 140kg.
- Supplier:** Embroidered fabric label fixed to side of backrest stating: Supplier, physical address and contact details.
- Warranty & Design:** Unit to be supplied with MINIMUM 5 year Warranty under normal office usage conditions. The specifications as contained in this document are the minimum NPA requirements. Vendor to take design responsibility & ensure correct specifications



RACK FILING SYSTEMS



Draft

1200w x 305d x 6s Rack Code:NPA-RACK-SR-1200-6



CODE Description

RACK	SR	1200	6
CATEGORY	DESCRIPTION	WIDTH	# FILE SHELVES excluding top shelf

NOTES:

- MAX height of RACK-02 unit 2210.
- Corner Angle System - NOT R.U.T.
- 6 shelf steel rack shown.
- Top shelf (shelf #7) for closing off of unit only, not for storage.

CAD DRAWING:



Design Requirement:

Supplier is to ensure that standard 315mm high Government files can be stored vertically on all 6 shelves. Min 9mm gap on top to be allowed for for file access.

TECHNICAL INFORMATION

- Size:** 1200mm wide x 305mm deep x 2210mm high.
- Finish:** Epoxy Powder Coated - Light Grey. Applies to all components.
- Carcass:** System designed to manufacturers details. Manufacturer to state warranty and max carrying capacity. Typical load is A4 paper in cardboard files stacked full width in high density. All components to be manufactured from cold rolled steel which is then degreased, phosphated, passivated and epoxy powder coated to SABS specification. All components from min 2mm thick sheet or greater if manufacturer requires/recommends.
- Panels:** Side Panels x2 and back panel to EVERY unit without exception, even when units are located back-to-back or side-to-side. Unit desing to allow side-2-side and back-2-back fixing with bolts.
- Shelves:** 7x shelves to be supplied. 6 shelves are for file storage. Top shelf (#7) to close off unit - not for actual file storage.
- Supplier:** Plasticised sticker fixed out of sight stating: Supplier's name, physical address and contact details
- Warranty & Design:** All units to carry a minimum 10 year Warranty under normal office environment or file storage room conditions. The specifications as contained in this document are the minimum NPA requirements. Vendor to take design responsibility and ensure correct specifications.



RACK FILING SYSTEMS



1200w x 305d x 7s Rack Code: NPA-RACK-SR-1200-7

Draft



CODE Description

RACK	SR	1200	7
CATEGORY	DESCRIPTION	WIDTH	# FILE SHELVES excluding top shelf

NOTE:

- MAX height of RACK-04 unit 2210.
- Corner Angle System - NOT R.U.T.
- 7 shelf 1200w steel rack shown.
- Top shelf (shelf #8) for closing off of top only, not for storage.

CAD DRAWING:



TECHNICAL INFORMATION

- Size:** 1200mm wide x 305mm deep x 2210mm high.
- Finish:** Epoxy Powder Coated - Light Grey. Applies to all components.
- Carcass:** System designed to manufacturers details. Manufacturer to state warranty and max carrying capacity. Typical load is A4 paper in cardboard files stacked full width in high density. All components to be manufactured from cold rolled steel which is then degreased, phosphated, passivated and epoxy powder coated to SABS specification. All components from min 2mm thick sheet or greater if manufacturer requires/recommends.
- Panels:** Side Panels x2 and back panel to EVERY unit without exception, even when units are located back-to-back or side-to-side. Unit desing to allow side-2-side and back-2-back fixing with bolts.
- Shelves:** 7x shelves to be supplied. 7 shelves are for file storage. Top shelf (#8) to close off unit - not for actual file storage.
- Supplier:** Plasticised sticker fixed out of sight stating: Supplier's name, physical address and contact details
- Warranty & Design:** All units to carry a minimum 10 year Guarantee under normal office environment or file storage room conditions. The specifications as contained in this document are the minimum NPA requirements. Vendor to take design responsibility and ensure correct specifications.



RACK FILING SYSTEMS



Draft

913w x 305d x 6s Rack Code:NPA-RACK-SR-913-6



CODE Description

RACK	SR	913	6
CATEGORY	DESCRIPTION	WIDTH	# FILE SHELVES excl. top shelf

NOTES:

- MAX height of RACK-01 unit 2210.
- Corner Angle System - NOT R.U.T.
- 6 shelf steel rack shown.
- Top shelf (shelf #7) for closing off of unit only, not for storage.

CAD DRAWING:



Design Requirement:

Supplier is to ensure that standard 315mm high Government files can be stored vertically on all 6 shelves. Min 9mm gap on top to be allowed for for file access.

TECHNICAL INFORMATION

- Size:** 913mm wide x 305mm deep x 2210mm high.
- Finish:** Epoxy Powder Coated - Light Grey. Applies to all components.
- Carcass:** System designed to manufacturers details. Manufacturer to state warranty and max carrying capacity. Typical load is A4 paper in 315mm high files stacked full width in high density. All components to be manufactured from cold rolled steel which is then degreased, phosphated, passivated and epoxy powder coated to SABS specification. All components from min 2mm thick sheet or greater if manufacturer requires/recommends.
- Panels:** Side Panels x2 and back panel to EVERY unit without exception, even when units are located back-to-back or side-to-side. Unit design to allow side-2-side and back-2-back fixing with bolts.
- Shelves:** 7x shelves to be supplied. 6 shelves are for file storage. Top shelf (#7) to close off unit - not for actual file storage.
- Supplier:** Plasticised sticker fixed out of sight stating: Supplier's name, physical address and contact details
- Warranty & Design:** All units to carry a minimum 10 year Warranty under normal office environment or file storage room conditions. The specifications as contained in this document are the minimum NPA requirements. Vendor to take design responsibility and ensure correct specifications.



OFFICE ACCESSORIES



Draft

SMART BOARD Code: NPA-IW-680



MANUFACTURER: VASTRATECH
or similar or equal
PRODUCT: Smart Board Interac-
tive Whiteboards
PRODUCT CODE:
SIZE: 77"

CODE Description

IW	680
CATEGORY	PRODUCT CODE

Barcode:

NPA issued barcode to be fixed to frame before delivery to site.

<http://www.vastratech.com>
(Manufacturers home page)
or similar or equal

DESCRIPTION: Smart Board Interactive Whiteboards feature projection and touch recognition, therefore being an interactive solution.

SIZE: 77" (195.6cm)

SUPPLIER: Plasticised sticker fixed out of sight, stating: supplier, physical address and contact details.

WARRANTY & DESIGN: All units to carry a minimum 5 year warranty under normal office environment conditions. The specifications as contained in this document are the minimum NPA requirements. Vendor to take design responsibility and ensure correct specifications.



FURNITURE SPECIFICATIONS



Draft

TABLE: Boardroom 12 Seat Code:NPA-TABLE-B-12

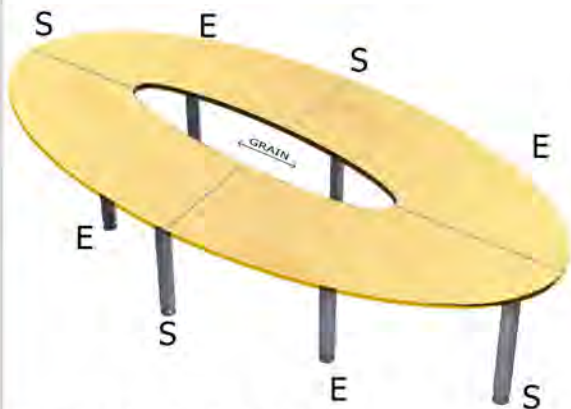

Typical 12 Seater Boardroom Table

FINISH



Vancouver Maple CDL

PIC	NO#	DESCRIPTION
	4x	BOARDROOM TABLE 4200mm x 1750mm (2 off 2100 x 875 top - LH) (2 off 2100 x 875 top - RH)
	4x	ECO LEG (E) Finish: SaddleWood Matt
	4x	STANDARD LEG (S) Finish: SaddleWood Matt
	8x	VARIABLE CONNECTOR

CAD Furniture Symbol:

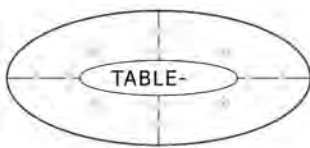

CODE Description

TABLE	B	12
CATEGORY	TYPE	SEATER

Barcode:

NPA issued barcode to be fixed under top before delivery to site.

TECHNICAL INFORMATION

- Dimensions:** 4200mm x 1750mm x 752mm high.
- Tabletop:** Constructed from four separate tops from 32mm thick tabletop substrate from high-density particle board with surface of 0.6mm Decon CDL. Each top to be pre-drilled and fitted with metal grommets to accommodate a M6x16 allen screw (5mm Allen Key). All parts not exposed / visible to get 0.2mm brown backer.
- Finish:** Top to be in Vancouver Maple CDL with 2mm maple finish flat edge high impact edging.
- Table Legs:** ECO and Standard Legs to be finished in SaddleWood Matt powder coated application. Non centre thread bolt type - sleeve thread only.
- Supplier:** Plasticised sticker fixed out of sight, stating: Supplier, physical address and contact details.
- Warranty & Design:** All units to carry a minimum 5 year warranty under normal office environment conditions. The specifications as contained in this document are the minimum NPA requirements. Vendor to take design responsibility & ensure correct specifications.



FURNITURE SPECIFICATIONS



TABLE: Boardroom 16 Seat Code: NPA-TABLE-B-16

Draft

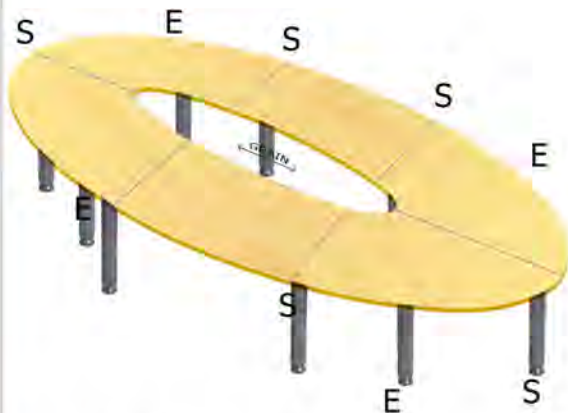

Typical 16 Seater Boardroom Table

FINISH



Vancouver Maple CDL

PIC	NO#	DESCRIPTION
	4x	BOARDROOM TABLE 4900mm x 1750mm (2 of 2100 x 875 top - LH) (2 of 2100 x 875 top - RH)
	2x	BOARDROOM TABLE 4900mm x 1750mm (2 of 700l x 627w)
	4x	ECO LEG (E) Finish: SaddleWood Matt
	6x	STANDARD LEG (S) Finish: SaddleWood Matt
	12x	VARIABLE CONNECTOR

CAD Furniture Symbol:

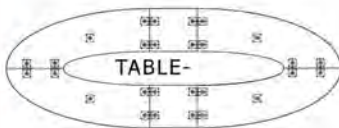

CODE Description

TABLE	B	16
CATEGORY	TYPE	SEATER

Barcode:

NPA issued barcode to be fixed under top before delivery to site.

TECHNICAL INFORMATION

- Dimensions:** 4900mm x 1750mm x 752mm high.
- Tabletop:** Constructed from four separate tops from 32mm thick tabletop substrate from high-density particle board with surface of 0.6mm Decon CDL. Each top to be pre-drilled and fitted with metal grommets to accommodate a M6x16 allen screw (5mm Allen Key). All parts not exposed / visible to get 0.2mm brown backer.
- Finish:** Top to be in Vancouver Maple CDL with 2mm maple finish flat edge high impact edging.
- Table Legs:** ECO and Standard Legs to be finished in SaddleWood Matt powder coated application. Non centre thread bolt type - sleeve thread only.
- Supplier:** Plasticised sticker fixed out of sight, stating: Supplier, physical address and contact details.
- Warranty & Design:** All units to carry a minimum 5 year warranty under normal office environment conditions. The specifications as contained in this document are the minimum NPA requirements. Vendor to take design responsibility & ensure correct specifications.



FURNITURE SPECIFICATIONS



Draft

TABLE: Boardroom 10 Seat Code:NPA-TABLE-B-20

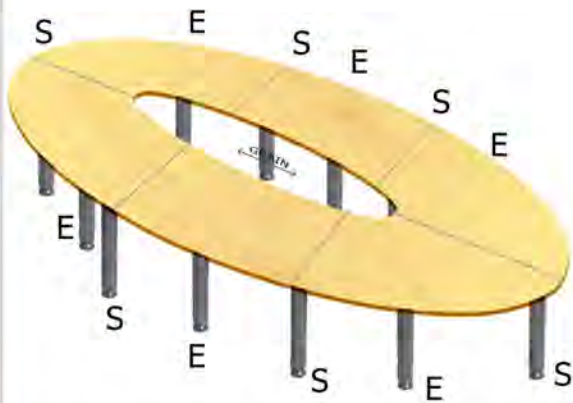





Typical 20 Seater Boardroom Table

FINISH



Vancouver Maple CDL

PIC	NO#	DESCRIPTION
	4x	BOARDROOM TABLE 6000mm x 1750mm (2 of 2100 x 875 top - LH) (2 of 2100 x 875 top - RH)
	2x	BOARDROOM TABLE 6000mm x 1750mm (2 of 1800l x 627w)
	6x	ECO LEG (E) Finish: SaddleWood Matt
	6x	STANDARD LEG (S) Finish: SaddleWood Matt
	12x	VARIABLE CONNECTOR

CAD Furniture Symbol:

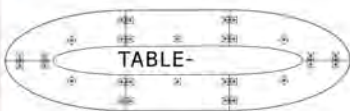

CODE Description

TABLE	B	20
CATEGORY	TYPE	SEATER

Barcode:

NPA issued barcode to be fixed under top before delivery to site.

TECHNICAL INFORMATION

Dimensions: 6000mm x 1750mm x 752mm high.
Tabletop: Constructed from separate 32mm thick tabletop substrate from high-density particle board with surface of 0.6mm Decon CDL. Each top to be pre-drilled and fitted with metal grommets to accommodate a M6x16 allen screw (5mm Allen Key). All parts not exposed / visible to get 0.2mm brown backer.

Finish: Top to be in Vancouver Maple CDL with 2mm maple finish flat edge high impact edging.
Table Legs: ECO and Standard Legs to be finished in SaddleWood Matt powder coated application. Non centre thread bolt type - sleeve thread only. Std legs to be fitted under joints in top.

Supplier: Plasticised sticker fixed out of sight. Stating: Supplier, physical address and contact details.
Warranty & Design: All units to carry a minimum 5 year warranty under normal office environment conditions. The specifications as contained in this document are the minimum NPA requirements. Vendor to take design responsibility & ensure correct specifications.



FURNITURE SPECIFICATIONS



Draft

TABLE: Boardroom 26 Seat Code:NPA-TABLE-B-26



Typical 9600 x 3600 26 Seater Boardroom Table

FINISH



Vancouver Maple CDL

CAD Furniture Symbol:

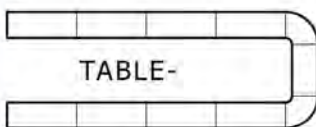

CODE Description

TABLE	B	26
CATEGORY	TYPE	SEATS

Barcode:

NPA issued barcode to be fixed under top before delivery to site.

TECHNICAL INFORMATION

- Dimensions:** 9600 x 3600 x 752mm high.
- Tabletop:** 32mm thick Tabletop substrate from high-density particle board with surface of 0.6mm Decon CDL. All tops to be pre-drilled and fitted with metal grommets to accommodate a M6x16 allen screw (5mm Allen Key). Possible electrical corporate connection boxes with flip-up lids. All parts not exposed / visible to get 0.2mm brown backer. Top to be in Vancouver Maple CDL with 2mm maple finish flat edge high impact edging.
- Finish:** 32mm thick substrates from high-density particle board with surface of 0.6mm Decon CDL.
- Table Legs:** CDS Plastics 'CMS03' 80mm Charcoal cable outlet positioned as per photo.
- Reticulation:** Possible electrical corporate connection boxes with flip-up lids.
- Electrical Box:** Plasticised sticker fixed out of sight, stating: Supplier, physical address and contact details.
- Supplier:** All units to carry a minimum 5 year warranty under normal office environment conditions.
- Warranty & Design:** The specifications as contained in this document are the minimum NPA requirements. Vendor to take design responsibility & ensure correct specifications.



FURNITURE SPECIFICATIONS



Draft

TABLE: Boardroom 6 Seat Code:NPA-TABLE-B-6





Typical 6 Seater Boardroom Table

FINISH



Vancouver Maple CDL

PIC	NO #	DESCRIPTION
	1x	BOARDROOM TABLE 2400mm x 1200mm
	6x	ECO LEG (E) Finish: SaddleWood Matt

CAD Furniture Symbol:

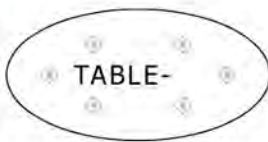

CODE Description

TABLE	B	6
CATEGORY	TYPE	SEATER

Barcode:

NPA issued barcode to be fixed under top before delivery to site.

TECHNICAL INFORMATION

- Dimensions:** 2400mm x 1200mm x 752mm high.
- Tabletop:** 32mm thick tabletop substrate from high-density particle board with surface of 0.6mm Decon CDL. Oval top to be pre-drilled and fitted with metal grommets to accommodate a M6x16 allen screw (5mm Allen Key). All parts not exposed / visible to get 0.2mm brown backer.
- Finish:** Top to be in Vancouver Maple CDL with 2mm maple finish flat edge high impact edging.
- Table Legs:** ECO and Standard Legs to be finished in SaddleWood Matt powder coated application. Non centre thread bolt type - sleeve thread only.
- Supplier:** Plasticised sticker fixed out of sight, stating: Supplier, physical address and contact details.
- Warranty & Design:** All units to carry a minimum 5 year warranty under normal office environment conditions. The specifications as contained in this document are the minimum NPA requirements. Vendor to take design responsibility & ensure correct specifications.



FURNITURE SPECIFICATIONS



TABLE: Boardroom 8 Seat Code: NPA-TABLE-B-8

Draft

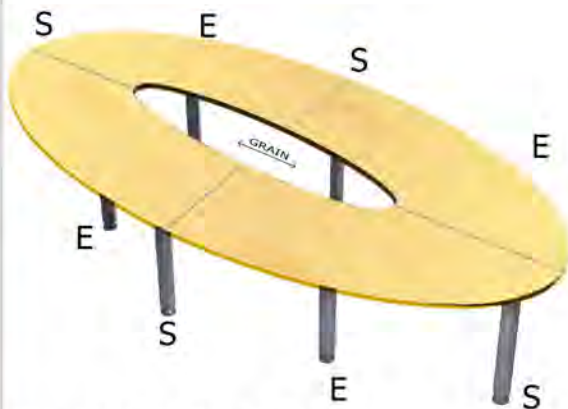





Typical 8 Seater Boardroom Table

FINISH



Vancouver Maple CDL

PIC	NO #	DESCRIPTION
	4x	BOARDROOM TABLE 3600mm x 1600mm (2 off 1800 x 800 top - LH) (2 off 1800 x 800 top - RH)
	4x	ECO LEG (E) Finish: SaddleWood Matt
	4x	STANDARD LEG (S) Finish: SaddleWood Matt
	8x	VARIABLE CONNECTOR

CAD Furniture Symbol:

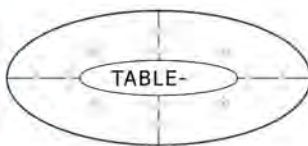

CODE Description

TABLE	B	8
CATEGORY	TYPE	SEATER

Barcode:

NPA issued barcode to be fixed under top before delivery to site.

TECHNICAL INFORMATION

- Dimensions:** 3600mm x 1600mm x 752mm high.
- Tabletop:** Constructed from four separate tops from 32mm thick tabletop substrate from high-density particle board with surface of 0.6mm Decon CDL. Each top to be pre-drilled and fitted with metal grommets to accommodate a M6x16 allen screw (5mm Allen Key). All parts not exposed / visible to get 0.2mm brown backer.
- Finish:** Top to be in Vancouver Maple CDL with 2mm maple finish flat edge high impact edging.
- Table Legs:** ECO and Standard Legs to be finished in SaddleWood Matt powder coated application. Non centre thread bolt type - sleeve thread only.
- Supplier:** Plasticised sticker fixed out of sight, stating: Supplier, physical address and contact details.
- Warranty & Design:** All units to carry a minimum 5 year warranty under normal office environment conditions. The specifications as contained in this document are the minimum NPA requirements. Vendor to take design responsibility & ensure correct specifications.



FURNITURE SPECIFICATIONS



Draft

Call Centre Desk (Left handed) Code: NPA-CCD-1400-LH

Typical Left Handed Call Centre WorkStation



FINISH



Vancouver Maple CDL

PIC	NO#	DESCRIPTION
	1x	STD C/C TOP 1400 x 1000
	1.5x	SNAIK -1000mm long
	4x	ECO LEG (E) Finish: SaddleWood Matt

CAD Furniture Symbol:

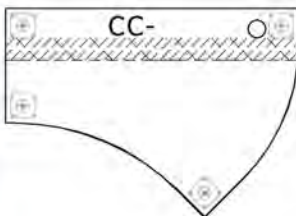

CODE Description

CCD	1400	L
CATEGORY	TOP	HANDED

Barcode:

NPA issued barcode to be fixed under top before delivery to site.

NOTE:

Left handed and Right handed must be ordered as SEPERATE codes. They are not the same.

CALL CENTRE DESK

- Dimensions:** 1400mm x 1000mm x 752mm high.
- Worktop:** 32mm thick worktop substrate from high-density particle board with surface of 0.6mm Decon CDL. All tops to be pre-drilled and fitted with metal grommets to accommodate a M6x16 allen screw (5mm Allen Key). All parts not exposed / visible to get 0.2mm brown backer.
- Reticulation:** CDS Plastics 'CMS03' 80mm Charcoal cable outlet positioned as per drawing. 1500mm long CDS Plastics "SNAIK" tray to underside of desk top as per drawing position.
- Finishes:** Top to be in Vancouver Maple CDL with 2mm maple finish flat edge high impact edging.
- Table Legs:** ECO and Standard Legs to be finished in SaddleWood Matt powder coated application. Non centre thread bolt type - sleeve thread only.
- Supplier:** Plasticised sticker fixed out of sight, stating: Supplier, physical address and contact details.
- Guarantee & Design:** All units to carry a minimum 5 year guarantee under normal office environment conditions. The specifications as contained in this document are the minimum NPA requirements. Vendor to take design responsibility & ensure correct specifications.



FURNITURE SPECIFICATIONS



Draft

Call Centre Desk (Right handed) Code: NPA-CCD-1400-RH

Typical Right Handed Call Centre WorkStation



FINISH



Vancouver Maple CDL

PIC	NO#	DESCRIPTION
	1x	STD C/C TOP 1400 x 1000
	1.5x	SNAIK -1000mm long
	4x	ECO LEG (E) Finish: SaddleWood Matt

CAD Furniture Symbol:

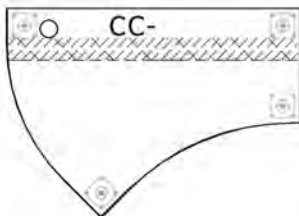

CODE Description

CCD **1400** **R**
 CATEGORY TOP HANDED

Barcode:

NPA issued barcode to be fixed under top before delivery to site.

NOTE:

Left handed and Right handed must be ordered as SEPERATE codes. They are not the same.

CALL CENTRE DESK

- Dimensions:** 1400mm x 1000mm x 752mm high.
- Worktop:** 32mm thick worktop substrate from high-density particle board with surface of 0.6mm Decon CDL. All tops to be pre-drilled and fitted with metal grommets to accommodate a M6x16 allen screw (5mm Allen Key). All parts not exposed / visible to get 0.2mm brown backer.
- Reticulation:** CDS Plastics 'CMS03' 80mm Charcoal cable outlet positioned as per drawing. 1500mm long CDS Plastics "SNAIK" tray to underside of desk top as per drawing position.
- Finishes:** Top to be in Vancouver Maple CDL with 2mm maple finish flat edge high impact edging.
- Table Legs:** ECO and Standard Legs to be finished in SaddleWood Matt powder coated application. Non centre thread bolt type - sleeve thread only.
- Supplier:** Plasticised sticker fixed out of sight, stating: Supplier, physical address and contact details.
- Guarantee & Design:** All units to carry a minimum 5 year guarantee under normal office environment conditions. The specifications as contained in this document are the minimum NPA requirements. Vendor to take design responsibility & ensure correct specifications.



FURNITURE SPECIFICATIONS



Draft

TABLE: STAINLESS STEEL PAUSE AREA Code: NPA-TABLE-ST-PA-S/S



MANUFACTURER: CHAIR EXPRESS
or similar or equal
PRODUCT: Sangria Table
SIZE: 800 x 800 x 710
FINISH: Stainless Steel

CODE Description

TABLE	ST	PA	S/S
CATEGORY	DESCRIPTION	TYPE	FINISH

Barcode:

NPA issued barcode to be fixed under top before delivery to site.

DESCRIPTION: Sangria Stainless Steel Pause Area table (or similar or equal).
800mm x 800mm x 710mm
SIZE: Plasticised sticker fixed out of sight, stating: supplier, physical address
SUPPLIER: and contact details.
WARRANTY & DESIGN: All units to carry a minimum 5 year warranty under normal office environment conditions. The specifications as contained in this document are the minimum NPA requirements. Vendor to take design responsibility and ensure correct specifications.



FURNITURE SPECIFICATIONS



Draft

TABLE: STAINLESS STEEL PAUSE AREA Code: NPA-TABLE-DT-PA-S/S



MANUFACTURER: CHAIR EXPRESS
or similar or equal
PRODUCT: Diablo Table
SIZE: 600 diameter x 1100h
FINISH: Stainless Steel

CODE Description

TABLE	DT	PA	S/S
CATEGORY	DESCRIPTION	TYPE	FINISH

Barcode:

NPA issued barcode to be fixed under top before delivery to site.

DESCRIPTION: Sangria Stainless Steel Pause Area table (or similar or equal).
SIZE: 600diameter x 1100mm high
SUPPLIER: Plasticised sticker fixed out of sight, stating: supplier, physical address and contact details.
WARRANTY & DESIGN: All units to carry a minimum 5 year warranty under normal office environment conditions. The specifications as contained in this document are the minimum NPA requirements. Vendor to take design responsibility and ensure correct specifications.



FURNITURE SPECIFICATIONS



Draft

TABLE: 1200 x 600 Coffee Table Code:NPA-TABLE-C-1200



1200 x 600 Vancouver Maple Coffee Table

FINISH



Vancouver Maple CDL

CAD Furniture Symbol:



CODE Description

TABLE	C	1200
CATEGORY	TYPE	SIZE

Barcode:

NPA issued barcode to be fixed to under top before delivery to site.

TECHNICAL INFORMATION

- Dimensions:** 1200mm x 600mm x 420mm high Viola table.
- Tabletop:** Table top from 32mm thick tabletop substrate from high-density particle board with surface of 0.6mm Decon CDL. All parts not exposed / visible to get 0.2mm brown backer.
- Finish:** Top to be in Vancouver Maple CDL with 2mm maple finish flat edge high impact edging.
- Table Legs:** Hollow section Vancouver Maple CDL clad tapered legs, curved at 45 degrees, with Maple fotpad.
- Supplier:** Plasticised sticker fixed out of sight, stating: Supplier, physical address and contact details.
- Warranty & Design:** All units to carry minimum of 5 years warranty under normal office environment conditions. The specifications as contained in this document are the minimum NPA requirements. Vendor to take design responsibility & ensure correct specifications.



FURNITURE SPECIFICATIONS



Draft

TABLE: 600 x 600 Coffee Table Code:NPA-TABLE-C-600



600 x 600 Vancouver Maple CDL Coffee Table

FINISH



Vancouver Maple CDL

CAD Furniture Symbol:

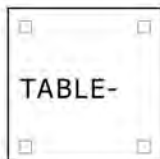

CODE Description

TABLE	C	600
CATEGORY	TYPE	SIZE (L & W)

Barcode:

NPA issued barcode to be fixed under top before delivery to site.

TECHNICAL INFORMATION

- Dimensions:** 600mm x 600mm x 420mm high Viola table.
- Tabletop:** Table top from 32mm thick tabletop substrate from high-density particle board with surface of 0.6mm Decon CDL. All parts not exposed / visible to get 0.2mm brown backer.
- Finishes:** Top to be in Vancouver Maple CDL with 2mm maple finish flat edge high impact edging.
- Table Legs:** Hollow section Vancouver Maple CDL clad tapered legs, curved at 45 degrees, with Maple footpad.
- Supplier:** Plasticised sticker fixed out of sight, stating: Supplier, physical address and contact details.
- Warranty & Design:** All units to carry minimum of 5 years warranty under normal office environment conditions. The specifications as contained in this document are the minimum NPA requirements. Vendor to take design responsibility & ensure correct specifications.



FURNITURE SPECIFICATIONS



Draft

TABLE: 900 x 600 Coffee Table Code:NPA-TABLE-C-900



900 x 600 Vancouver Maple CDL Coffee Table

FINISH



Vancouver Maple CDL

CAD Furniture Symbol:



CODE Description

TABLE	C	900
CATEGORY	TYPE	SIZE

Barcode:

NPA issued barcode to be fixed to maple edge before delivery to site.

TECHNICAL INFORMATION

- Dimensions:** 900 x 600mm x 420mm high Viola table.
- Tabletop:** Table top from 32mm thick tabletop substrate from high-density particle board with surface of 0.6mm Deccon CDL. All parts not exposed / visible to get 0.2mm brown backer.
- Finish:** Top to be in Vancouver Maple CDL with 2mm maple finish flat edge high impact edging.
- Table Legs:** Hollow section Vancouver Maple CDL clad tapered legs, curved at 45 degrees, with Maple footpad.
- Supplier:** Plasticised sticker fixed out of sight, stating: Supplier, physical address and contact details.
- Warranty & Design:** All units to carry minimum of 5 years warranty under normal office environment conditions. The specifications as contained in this document are the minimum NPA requirements. Vendor to take design responsibility & ensure correct specifications.



TROLLEYS



CONSULTANT'S PC TABLE: Code: NPA-TABLE-CPT

Draft



FINISH



Vancouver Maple Veneer

Barcode:

NPA issued barcode to be fixed to top before delivery to site.

CAD Furniture Symbol:



Adjustable veneer shelf with negative chamfer routed edge

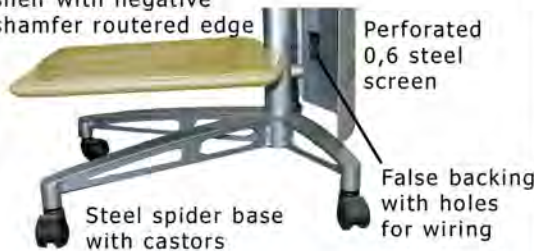

Perforated 0,6 steel screen

Steel spider base with castors

False backing with holes for wiring

CODE Description

TABLE	CPT
-------	-----

CATEGORY

DESCRIPTION

TECHNICAL DATA:

Dimensions: 1100h x 600w x 550d

Description: Steel spider base & 50mm diameter post supporting 0,6mm perforated steel screen at back, fixed veneer top shelf and bottom shelf adjustable at 50mm intervals. Steel screen to have false backing with openings for wiring

Timber: Shelves to be 22mm thick substrate from high-density particle board with surface of 0,7mm Vancouver Maple veneer. All parts not exposed / visible to get 0.2mm brown backer.

Steel: All metal to be pre drilled and powder coated silver.

Reticulation: CDS Plastics 'CMS03' 80mm Charcoal cable outlet positioned in top shelf over post.

Finishes: First Coat sanding sealer, Fill board and sand down, Second Coat sanding sealer, Sand down, Apply colour if applicable, 3x Coats "Chemspec" or similar or equal product thinners based Satin Matt varnish with A-C catalyst, sprayed on. Allow to dry between coats. Routed edge with negative chamfer as per image.

Castors: Free swivelling Castor Wheels lattice-reinforced (minimum of 8 fins) nylon type or polyurethane (for tiles areas) in colourfast black matt finish. Castor size: Min 65mm diameter of physical wheel.

Supplier: Plasticised sticker fixed out of view, stating: Supplier's name, physical address and contact details.

Warranty & Design: Five years warranty under normal Office environment conditions. The specifications as contained in this document are the minimum NPA requirements. Vendor to take design responsibility & ensure correct specifications. System designed to manufacturers details. Manufacturer to state max carrying capacity.



FURNITURE SPECIFICATIONS



Draft

CONSULTANT'S TABLE Code: NPA-TABLE-TC-CN-1600

1600 x 800 Typical Consultant Table



CAD Furniture Symbol:

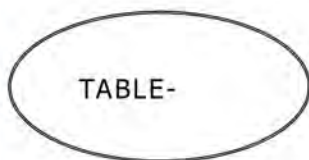

FINISH



Vancouver Maple Veneer

CODE Description

TABLE	TC	CN	1600
CATEGORY	DESCRIPTION	TYPE	TOP

Barcode:

NPA issued barcode to be fixed under top before delivery to site.

TECHNICAL INFORMATION

- Dimensions:** 1600 wide x 800 deep x 732 high.
- Tabletop:** 22mm thick tabletop substrate from high-density particle board with surface of 0,7mm Vancouver Maple veneer. All parts not exposed / visible to get 0.2mm brown backer.
- Finishes:** Top to be in Vancouver Maple veneer with 2,5mm solid Maple edging. First Coat sanding sealer, Fill board and sand down, Second Coat sanding sealer, Sand down, Apply colour if applicable, 3x Coats "Chemspec" or similar or equal product thinners based Satin Matt varnish with A-C catalyst, sprayed on. Allow to dry between coats.
- Table Legs:** Adjustable steel V-legs as per image, powder coated silver.
- Supplier:** Plasticised sticker fixed out of sight, stating: Supplier, physical address and contact details.
- Warranty & Design:** All units to carry a minimum 5 year warranty under normal office environment conditions. The specifications as contained in this document are the minimum NPA requirements. Vendor to take design responsibility & ensure correct specifications.



FURNITURE SPECIFICATIONS



Draft

TABLE: Boardroom 16 Seat Code: NPA-TABLE-EX-B-16



Typical 16 Seater Boardroom Table

FINISH



Vancouver Maple Veneer

PIC	NO#	DESCRIPTION
	4x	BOARDROOM TABLE 4900mm x 1750mm (2 of 2100 x 875 top - LH) (2 of 2100 x 875 top - RH)
	2x	BOARDROOM TABLE 4900mm x 1750mm (2 of 700l x 627w)
	6x	22mm Supawood / plywood carcass with removable panel
	1x	Removable Black Leather Inlay
	12x	VARIABLE CONNECTOR

CAD Furniture Symbol:

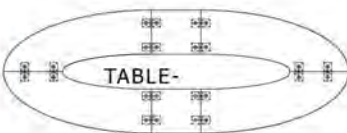

CODE Description

TABLE	EX	B	16
CATEGORY	DESCRIPTION	TYPE	SEATER

Barcode:

NPA issued barcode to be fixed under top before delivery to site.

This item is ONLY for Executive areas

TECHNICAL INFORMATION

- Dimensions:** 4900mm x 1750mm x 752mm high.
- Tabletop:** Table top from separate 32mm thick tabletop substrate from high-density particle board with surface of 0,7mm Vancouver Maple veneer. Top to be pre-drilled and fitted with metal grommets to accommodate a M6x16 allen screw (5mm Allen Key). Flush leather inlay as per catalog. All parts not exposed / visible to get 0.2mm brown backer.
- Edging:** Solid Vancouver Maple edging with 45 degree negative chamfer.
- Finish:** First Coat sanding sealer, Fill board and sand down, Second Coat sanding sealer, Sand down, Apply colour if applicable, 3x Coats "Chemspec" or similar or equal product thinners based High Gloss varnish with A-C catalyst, sprayed on. Allow to dry between coats.
- Leather Inlay:** Leather-covered inlay panel to be removable from beneath for future reticulation. Possible electrical corporate connection boxes with flip-up lids may be required for installation in leather panel.
- Table Leg:** Leg structure to be 22mm supawood and/or 22mm plywood carcass base shaped to oval base in minimum four sections. Fixed to underside of table top with suitable galvanized steel brackets or similar suitable method to specialist and NPA approval. Minimum one base section must be removable for reticulation access after installation of table. Base to be finished in Black Satin sheen duco spray finish. No supawood parts to be in contact with floor. Provide min 10mm floated shadow line to avoid any contact with water (floor mopping) Supawood sealed against water damage under normal office environment circumstances, including floor mopping.
- Supplier:** Plasticised sticker fixed out of sight, stating: Supplier, physical address and contact details.
- Warranty & Design:** All units to carry minimum of 5 years warranty under normal office environment conditions. The specifications as contained in this document are the minimum NPA requirements. Vendor to take design responsibility & ensure correct specifications.



FURNITURE SPECIFICATIONS



TABLE: Boardroom 12 Seat Code: NPA-TABLE-EX-B-12

Draft



Typical 12 Seater Boardroom Table

CAD Furniture Symbol:

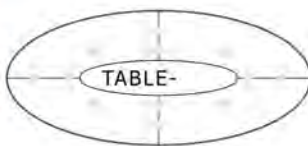

CODE Description

TABLE	EX	B	12
CATEGORY	DESCRIPTION	TYPE	SEATER

Barcode:

NPA issued barcode to be fixed under top before delivery to site.

FINISH



Vancouver Maple Veneer

PIC	NO #	DESCRIPTION
	4x	BOARDROOM TABLE 4200mm x 1750mm (2 of 2100 x 875 top - LH) (2 of 2100 x 875 top - RH)
	4x	22mm Supawood / plywood carcass with removable panel
	1x	Removable Black Leather Inlay
	8x	VARIABLE CONNECTOR

This item IS ONLY for
Executive areas

TECHNICAL INFORMATION

- Dimensions:** 4200mm x 1750mm x 752mm high.
- Tabletop:** Constructed from four separate tops from 32mm thick tabletop substrate from high-density particle board with surface of 0,7mm Vancouver Maple veneer. Top to be pre-drilled and fitted with metal grommets to accommodate a M6x16 allen screw (5mm Allen Key). Flush leather inlay as per catalog. All parts not exposed / visible to get 0.2mm brown backer.
- Edging:** Solid Vancouver Maple edging with 45 degree negative chamfer.
- Finish:** First Coat sanding sealer, Fill board and sand down, Second Coat sanding sealer, Sand down, Apply colour if applicable, 3x Coats "Chemspec" or similar or equal product thinners based High Gloss varnish with A-C catalyst, sprayed on. Allow to dry between coats.
- Leather Inlay:** Leather-covered inlay panel to be removable from beneath for future reticulation. Possible electrical corporate connection boxes with flip-up lids may be required for installation in leather panel.
- Table Leg:** Leg structure to be 22mm supawood and/or 22mm plywood carcass base shaped to oval base in minimum four sections. Fixed to underside of table top with suitable galvanized steel brackets or similar suitable method to specialist and NPA approval. Minimum one base section must be removable for reticulation access after installation of table. Base to be finished in Black Satin sheen duco spray finish. No supawood parts to be in contact with floor. Provide min 10mm floated shadow line to avoid any contact with water (floor mopping) Supawood sealed against water damage under normal office environment circumstances, including floor mopping. Plasticised sticker fixed out of sight, stating: Supplier, physical address and contact details. All units to carry minimum of 5 years warranty under normal office environment conditions. The specifications as contained in this document are the minimum NPA requirements. Vendor to take design responsibility & ensure correct specifications.
- Supplier:**
- Warranty & Design:**



FURNITURE SPECIFICATIONS



TABLE: Executive Boardroom 20 Seat Code: NPA-TABLE-EX-B-20

Draft



Typical 20 Seater Boardroom Table

FINISH



Vancouver Maple Veneer





CAD Furniture Symbol:

CODE Description

TABLE	EX	B	20
CATEGORY	DESCRIPTION	TYPE	SEATER

Barcode:

NPA issued barcode to be fixed under top before delivery to site.

PIC	NO#	DESCRIPTION
	4x	BOARDROOM TABLE 4900mm x 1750mm (2 of 2100 x 875 top - LH) (2 of 2100 x 875 top - RH)
	2x	BOARDROOM TABLE 4900mm x 1750mm (2 of 700l x 627w)
	6x	22mm Supawood / plywood carcass with removable panel
	1x	Removable Black Leather Inlay
	12x	VARIABLE CONNECTOR

This item IS ONLY for Executive areas

TECHNICAL INFORMATION

- Dimensions:** 6000mm x 1750mm x 752mm high.
- Tabletop:** Table top from 32mm thick tabletop substrate from high-density particle board with surface of 0,7mm Vancouver Maple veneer. Top to be pre-drilled and fitted with metal grommets to accommodate a M6x16 allen screw (5mm Allen Key). Flush leather inlay as per catalog. All parts not exposed / visible to get 0.2mm brown backer.
- Edging:** Solid Vancouver Maple edging with 45 degree negative chamfer.
- Finish:** First Coat sanding sealer, Fill board and sand down, Second Coat sanding sealer, Sand down, Apply colour if applicable, 3x Coats "Chemspec" or similar or equal product thinners based High Gloss varnish with A-C catalyst, sprayed on. Allow to dry between coats.
- Leather Inlay:** Leather-covered inlay panel to be removable from beneath for future reticulation. Possible electrical corporate connection boxes with flip-up lids may be required for installation in leather panel.
- Table Leg:** Leg structure to be 22mm supawood and/or 22mm plywood carcass base shaped to oval base in minimum four sections. Fixed to underside of table top with suitable galvanized steel brackets or similar suitable method to specialist and NPA approval. Minimum one base section must be removable for reticulation access after installation of table. Base to be finished in Black Satin sheen duco spray finish. No supawood parts to be in contact with floor. Provide min 10mm floated shadow line to avoid any contact with water (floor mopping) Supawood sealed against water damage under normal office environment circumstances, including floor mopping.
- Supplier:** Plasticised sticker fixed out of sight, stating: Supplier, physical address and contact details.
- Warranty & Design:** All units to carry minimum of 5 years warranty under normal office environment conditions. The specifications as contained in this document are the minimum NPA requirements. Vendor to take design responsibility & ensure correct specifications.



FURNITURE SPECIFICATIONS



Draft

TABLE: Executive Boardroom 26 Seat Code: NPA-TABLE-EX-B-26



Typical 9600 x 3600
26 Seater Boardroom Table

FINISH



Vancouver Maple Veneer

Maple edge:
Negative
45 degree
shamfer



CDS Plastics 'CMS03'
80mm Charcoal
cable outlet



Maple edge:
Negative
45 degree
shamfer

CAD Furniture Symbol:

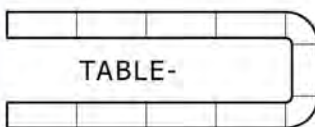

CODE Description

TABLE	EX	B	26
CATEGORY	DESCRIPTION	TYPE	SEATS

Barcode:

NPA issued barcode to be fixed under top before delivery to site.

This item is ONLY for Executive areas

TECHNICAL INFORMATION

- Dimensions:** 9600 x 3600 x 752mm high.
- Tabletop:** 32mm thick Tabletop substrate from high-density particle board with surface of 0,7mm Vancouver Maple Veneer. All tops to be pre-drilled and fitted with metal grommets to accommodate a M6x16 allen screw (5mm Allen Key). All parts not exposed / visible to get 0.2mm brown backer.
- Edging:** Table top: Solid Vancouver Maple edging with 45 degree negative chamfer. All other edges 2,5mm solid Maple with straight joints
- Finish:** First Coat sanding sealer, Fill board and sand down, Second Coat sanding sealer, Sand down, Apply colour if applicable, 3x Coats "Chemspec" or similar or equal product thinners based High Gloss varnish with A-C catalyst, sprayed on. Allow to dry between coats.
- Table Legs:** 32mm thick substrates from high-density particle board with surface of 0,7mm Vancouver Maple veneer.
- Reticulation:** CDS Plastics 'CMS03' 80mm Charcoal cable outlet positioned as per photo.
- Electrical Box:** Possible electrical corporate connection boxes with flip-up lids.
- Supplier:** Plasticised sticker fixed out of sight, stating: Supplier, physical address and contact details.
- Warranty & Design:** All units to carry a minimum 5 year warranty under normal office environment conditions. The specifications as contained in this document are the minimum NPA requirements. Vendor to take design responsibility & ensure correct specifications.



FURNITURE SPECIFICATIONS



TABLE: Boardroom 8 Seat Code: NPA-TABLE-EX-B-8

Draft



FINISH



Vancouver Maple Veneer

PIC	NO #	DESCRIPTION
	4x	BOARDROOM TABLE 3600mm x 1600mm (2 off 1800 x 800 top - LH) (2 off 1800 x 800 top - RH)
	4x	22mm Supawood / plywood carcass with removable panel
	1x	Removable Black Leather Inlay
	8x	VARIABLE CONNECTOR

CAD Furniture Symbol:

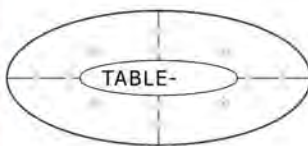

CODE Description

TABLE	EX	B	8
CATEGORY	DESCRIPTION	TYPE	SEATER

Barcode:

NPA issued barcode to be fixed under top before delivery to site.

This item is ONLY for Executive areas

TECHNICAL INFORMATION

- Dimensions:** 3600mm x 1600mm x 752mm high.
- Tabletop:** Constructed from four separate tops from 32mm thick tabletop substrate from high-density particle board with surface of 0,7mm Vancouver Maple veneer. Flush leather inlay as per catalog. All parts not exposed / visible to get 0.2mm brown backer.
- Edging:** Solid Vancouver Maple edging with 45 degree negative chamfer.
- Finish:** First Coat sanding sealer, Fill board and sand down, Second Coat sanding sealer, Sand down, Apply colour if applicable, 3x Coats "Chemspec" or similar or equal product thinners based High Gloss varnish with A-C catalyst, sprayed on. Allow to dry between coats.
- Leather Inlay:** Leather-covered inlay panel to be removable from beneath for future reticulation. Possible electrical corporate connection boxes with flip-up lids may be required for installation in leather panel.
- Table Leg:** Leg structure to be 22mm supawood and/or 22mm plywood carcass base shaped to oval base in minimum four sections. Fixed to underside of table top with suitable galvanized steel brackets or similar suitable method to specialist and NPA approval. Minimum one base section must be removable for reticulation access after installation of table. Base to be finished in Black Satin sheen duco spray finish. No supawood parts to be in contact with floor. Provide min 10mm floated shadow line to avoid any contact with water (floor mopping) Supawood sealed against water damage under normal office environment circumstances, including floor mopping. Plasticised sticker fixed out of sight, stating: Supplier, physical address and contact details.
- Supplier: Warranty & Design:** All units to carry minimum of 5 years warranty under normal office environment conditions. The specifications as contained in this document are the minimum NPA requirements. Vendor to take design responsibility & ensure correct specifications.



FURNITURE SPECIFICATIONS



Draft

TABLE: 600 x 600 Coffee Table Code:NPA-TABLE-EX-C-600



600 x 600 Vancouver Maple Veneer Coffee Table

FINISH



Vancouver Maple Veneer



CAD Furniture Symbol:

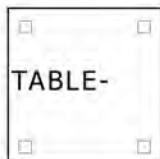

CODE Description

TABLE	EX	C	600
CATEGORY	DESCRIPTION	TYPE	SIZE (L & W)

Barcode:

NPA issued barcode to be fixed under top before delivery to site.

Maple veneer only
for Executive area

TECHNICAL INFORMATION

- Dimensions:** 600mm x 600mm x 420mm high Viola table.
- Tabletop:** Table top from 32mm thick tabletop substrate from high-density particle board with surface of 0,7mm Vancouver Maple veneer. All parts not exposed / visible to get 0.2mm brown backer.
- Edging:** 45 degree negative chamfer. 2,5mm solid Maple edging with straight joints.
- Finishes:** First Coat sanding sealer, Fill board and sand down, Second Coat sanding sealer, Sand down, Apply colour if applicable, 3x Coats "Chemspec" or similar or equal product thinners based High Gloss varnish with A-C catalyst, sprayed on. Allow to dry between coats.
- Table Legs:** Hollow section Vancouver Maple veneer clad tapered legs, curved at 45 degrees, with 22mm high solid Maple veneer footpad.
- Supplier:** Plasticised sticker fixed out of sight, stating: Supplier, physical address and contact details.
- Warranty & Design:** All units to carry minimum of 5 years warranty under normal office environment conditions. The specifications as contained in this document are the minimum NPA requirements. Vendor to take design responsibility & ensure correct specifications.



FURNITURE SPECIFICATIONS



Draft

TABLE: 1200 x 600 Coffee Table Code: NPA-TABLE-EX-C-1200



1200 x 600 Vancouver Maple Veneer Coffee Table

FINISH



Vancouver Maple Veneer



CAD Furniture Symbol:



CODE Description

TABLE	EX	C	1200
CATEGORY	DESCRIPTION	TYPE	SIZE

Barcode:

NPA issued barcode to be fixed to maple edge before delivery to site.

Maple veneer only
for Executive area

TECHNICAL INFORMATION

- Dimensions:** 1200 x 600mm x 420mm high Viola table.
- Tabletop:** Table top from 32mm thick tabletop substrate from high-density particle board with surface of 0,7mm Vancouver Maple veneer. All parts not exposed / visible to get 0.2mm brown backer.
- Finish:** 45 degree negative chamfer. 2,5mm solid Maple edging with straight joints.
First Coat sanding sealer, Fill board and sand down, Second Coat sanding sealer, Sand down, Apply colour if applicable, 3x Coats "Chemspec" or similar or equal product thinners based High Gloss varnish with A-C catalyst, sprayed on. Allow to dry between coats.
- Table Legs:** Hollow section Vancouver Maple veneer clad tapered legs, curved at 45 degrees, with 22mm high solid Maple veneer footpad.
- Supplier:** Plasticised sticker fixed out of sight, stating: Supplier, physical address and contact details.
- Warranty & Design:** All units to carry minimum of 5 years warranty under normal office environment conditions.
The specifications as contained in this document are the minimum NPA requirements. Vendor to take design responsibility & ensure correct specifications.



FURNITURE SPECIFICATIONS



Draft

TABLE: 900 x 600 Coffee Table Code:NPA-TABLE-EX-C-900



900 x 600 Vancouver Maple Veneer Coffee Table

FINISH



Vancouver Maple Veneer



CAD Furniture Symbol:



CODE Description

TABLE	EX	C	900
CATEGORY	DESCRIPTION	TYPE	SIZE

Barcode:

NPA issued barcode to be fixed to maple edge before delivery to site.

Maple veneer only
for Executive area

TECHNICAL INFORMATION

- Dimensions:** 900 x 600mm x 420mm high Viola table.
- Tabletop:** Table top from 32mm thick tabletop substrate from high-density particle board with surface of 0,7mm Vancouver Maple veneer. All parts not exposed / visible to get 0.2mm brown backer.
- Finish:** 45 degree negative chamfer. 2,5mm solid Maple edging with straight joints.
First Coat sanding sealer, Fill board and sand down, Second Coat sanding sealer, Sand down, Apply colour if applicable, 3x Coats "Chemspec" or similar or equal product thinners based High Gloss varnish with A-C catalyst, sprayed on. Allow to dry between coats.
- Table Legs:** Hollow section Vancouver Maple veneer clad tapered legs, curved at 45 degrees, with 22mm high solid Maple veneer footpad.
- Supplier:** Plasticised sticker fixed out of sight, stating: Supplier, physical address and contact details.
- Warranty & Design:** All units to carry minimum of 5 years warranty under normal office environment conditions.
The specifications as contained in this document are the minimum NPA requirements. Vendor to take design responsibility & ensure correct specifications.



FURNITURE SPECIFICATIONS



Draft

TABLE: EXEC PEAR MEETING TABLE

Code:NPA-TABLE-EX-M



Typical 1403 x 773
Pear-Shaped Meeting Room Table

FINISH



Vancouver Maple Veneer

CAD Furniture Symbol:

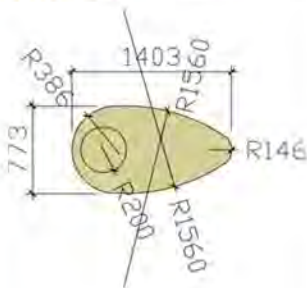

CODE Description

TABLE	EX	M
CATEGORY	DESCRIPTION	TYPE

Barcode:

NPA issued barcode to be fixed under top before delivery to site.

This item is ONLY for Executive areas

TECHNICAL INFORMATION

Dimensions: 1403mm length x 773mm width x 752mm height.

Tabletop: Table top from 32mm thick tabletop substrate from high-density particle board with surface of 0,7mm Vancouver Maple veneer. Top to be pre-drilled and fitted with metal grommets to accommodate a M6x16 allen screw (5mm Allen Key). Genuine round leather insert. All parts not exposed / visible to get 0.2mm brown backer. 45 degree negative chamfer. 2,5mm solid Maple edging with straight joints.

Edging: First Coat sanding sealer, Fill board and sand down, Second Coat sanding sealer, Sand down, Apply colour if applicable, 3x Coats "Chemspec" or similar or equal product thinners based High Gloss varnish with A-C catalyst, sprayed on. Allow to dry between coats.

Table Legs: ECO Legs to be finished in SaddleWood Matt powder coated application. Non centre thread bolt type - sleeve thread only.
Supplier: Plasticised sticker fixed out of sight, stating: Supplier, physical address and contact details.
Warranty & Design: All units to carry minimum of 5 years warranty under normal office environment conditions. The specifications as contained in this document are the minimum NPA requirements. Vendor to take design responsibility & ensure correct specifications.



FURNITURE SPECIFICATIONS



Draft

TABLE: 1200 x 650 Multi Usage Code:NPA-TABLE-1-MU-2

1200 x 650 Multifunctional Unit



FINISH



Vancouver Maple CDL

CAD Furniture Symbol:

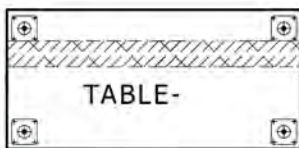

CODE Description

TABLE	1	MU	2
CATEGORY	UNIT	TYPE	SEATER

Barcode:

NPA issued barcode to be fixed under top before delivery to site.

PIC	NO #	DESCRIPTION
	1.5x	SNAIK -1000mm long
	1x	TOP 1200w x 650d
	4x	ECO LEG (E) Finish: SaddleWood Matt

MEETING ROOM - MULTI USAGE TABLE

- Dimensions:** 1200 wide x 650 deep x 752 high.
- Tabletop:** 32mm thick tabletop substrate from high-density particle board with surface of 0.6mm Decon CDL. Top to be pre-drilled and fitted with metal grommets to accommodate a M6x16 allen screw (5mm Allen Key). All parts not exposed / visible to get 0.2mm brown backer.
- Reticulation:** 1200mm long CDS Plastics "SNAIK" tray to underside of desk top as per drawing position.
- Finishes:** Top to be in Vancouver Maple CDL with 2mm maple finish flat edge high impact edging.
- Table Legs:** ECO and Standard Legs to be finished in SaddleWood Matt powder coated application. Non centre thread bolt type - sleeve thread only.
- Supplier:** Plasticised sticker fixed out of sight, stating: Supplier, physical address and contact details.
- Warranty & Design:** All units to carry a minimum 5 year warranty under normal office environment conditions. The specifications as contained in this document are the minimum NPA requirements. Vendor to take design responsibility & ensure correct specifications.



FURNITURE SPECIFICATIONS



Draft

TABLE: 1500 x 650 Multi Usage Code:NPA-TABLE-2-MU-2



1500x650 Multifunctional Unit



FINISH



Vancouver Maple CDL

PIC	NO #	DESCRIPTION
	1.5x	SNAIK -1000mm long
	1x	TOP 1500w x 650d
	4x	ECO LEG (E) Finish: SaddleWood Matt

CAD Furniture Symbol:

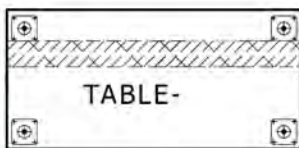

t

CODE Description

TABLE	2	MU	2
CATEGORY	UNIT	TYPE	SEATER

Barcode:

NPA issued barcode to be fixed under top before delivery to site.

MEETING ROOM - MULTI USAGE TABLE

- Dimensions:** 1500 wide x 650 deep x 752 high.
- Tabletop:** 32mm thick tabletop substrate from high-density particle board with surface of 0.6mm Decon CDL. Top to be pre-drilled and fitted with metal grommets to accommodate a M6x16 allen screw (5mm Allen Key). All parts not exposed / visible to get 0.2mm brown backer.
- Reticulation:** 1500mm long CDS Plastics "SNAIK" tray to underside of desk top as per drawing position.
- Finishes:** Top to be in Vancouver Maple CDL with 2mm maple finish flat edge high impact edging.
- Table Legs:** ECO and Standard Legs to be finished in SaddleWood Matt powder coated application. Non centre thread bolt type - sleeve thread only.
- Supplier:** Plasticised sticker fixed out of sight, stating: Supplier, physical address and contact details.
- Warranty & Design:** All units to carry a minimum 5 year warranty under normal office environment conditions. The specifications as contained in this document are the minimum NPA requirements. Vendor to take design responsibility & ensure correct specifications.



FURNITURE SPECIFICATIONS



Draft

MULTI USE TABLE: 1350 x 600

Code: NPA-TABLE-3-MU-2

Similar or equal to patented "Zip" table by "Burocentrum" If not "Zip", mockup to be made for NPA approval

1350x600 Foldable Table



FINISH



Vancouver Maple CDL

CAD Furniture Symbol:

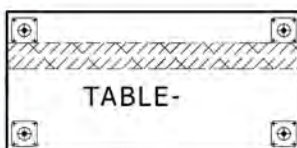

CODE Description

TABLE	3	MU	2
CATEGORY	UNIT	TYPE	SEATER

Barcode:

NPA issued barcode to be fixed under top before delivery to site.

PIC	NO#	DESCRIPTION
	1.35x	SNAIK -1000mm long
	1x	TOP 1350w x 600d
	4x	FOLDABLE LEGS Finish: Light Grey Matt
	1x	PERFORATED MODESTY PANEL Finish: Light Grey Matt

TECHNICAL INFORMATION

- Description:** Vertical stackable folding table with lockable castors. Similar or equal to patented "Zip" table by "Burocentrum"
- Dimensions:** 1350 wide x 600 deep x 732 high.
- Tabletop:** 22mm thick tabletop substrate from high-density particle board with surface of 0.6mm Decon CDL. Underside of top to get 0.2mm brown backer.
- Reticulation:**
- Finishes:** Top to be in Vancouver Maple CDL with 2mm maple finish flat edge high impact edging. Frame min 80 micron light grey epoxy power coated 24.5mm diameter mild steel frame - CNC machine bent and rolled.
- Table Legs:** Folding steel frame with lockable castors. Similar or equal to patented "Zip" table by "Burocentrum"
- Supplier:** Plasticised sticker fixed out of sight, stating: Supplier, physical address and contact details.
- Warranty & Design:** All units to carry a minimum 5 year warranty under normal office environment conditions. The specifications as contained in this document are the minimum NPA requirements. Vendor to take design responsibility & ensure correct specifications.



FURNITURE SPECIFICATIONS



Draft

TABLE: 900 Round 2 Seat Code:NPA-TABLE-M-2



Typical 900mm diameter
2 Seater Meeting Table

FINISH



Vancouver Maple CDL

PIC	NO #	DESCRIPTION
	1x	900 Dia. Top
	4x	ECO LEG (E) Finish: SaddleWood Matt

CAD Furniture Symbol:

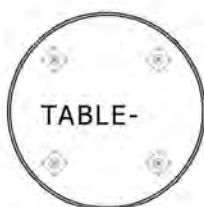

CODE Description

TABLE	M	2
CATEGORY	TYPE	SEATER

Barcode:

NPA issued barcode to be fixed under top before delivery to site.

TECHNICAL INFORMATION

- Dimensions:** 900mm diameter x 752mm high.
- Tabletop:** Table from single piece 32mm thick tabletop substrate from high-density particle board with surface of 0.6mm Decon CDL. Top to be pre-drilled and fitted with metal grommets to accommodate a M6x16 allen screw (5mm Allen Key). All parts not exposed / visible to get 0.2mm brown backer.
- Finishes:** Top to be in Vancouver Maple CDL with 2mm maple finish flat edge high impact edging.
- Table Legs:** ECO and Standard Legs to be finished in SaddleWood Matt powder coated application. Non centre thread bolt type - sleeve thread only.
- Supplier:** Plasticised sticker fixed out of sight, stating: Supplier, physical address and contact details.
- Warranty & Design:** All units to carry a minimum 5 year warranty under normal office environment conditions. The specifications as contained in this document are the minimum NPA requirements. Vendor to take design responsibility & ensure correct specifications.



FURNITURE SPECIFICATIONS



Draft

TABLE: 1800 Round 8 Seat Code:NPA-TABLE-M-8



FINISH



Vancouver Maple CDL

PIC	NO#	DESCRIPTION
	2x	1800 Dia. Half Top
	2x	ECO LEG (E) Finish: SaddleWood Matt
	2x	STANDARD LEG (S) Finish: SaddleWood Matt
	3x	VARIABLE CONNECTOR

CAD Furniture Symbol:

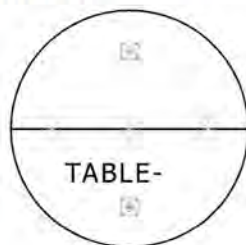

CODE Description

TABLE	M	8
CATEGORY	TYPE	SEATER

Barcode:

NPA issued barcode to be fixed under top before delivery to site.

TECHNICAL INFORMATION

- Dimensions:** 1800mm diameter x 752mm high.
- Tabletop:** Table from 2 "D-End" tops from 32mm thick tabletop substrate from high-density particle board with surface of 0.6mm Decon CDL. Tops to be pre-drilled and fitted with metal grommets to accommodate a M6x16 allen screw (5mm Allen Key). All parts not exposed / visible to get 0.2mm brown backer.
- Finishes:** Top to be in Vancouver Maple CDL with 2mm maple finish flat edge high impact edging.
- Table Legs:** ECO and Standard Legs to be finished in SaddleWood Matt powder coated application. Non centre thread bolt type - sleeve thread only.
- Supplier:** Plasticised sticker fixed out of sight, stating: Supplier, physical address and contact details.
- Warranty & Design:** All units to carry a minimum 5 year warranty under normal office environment conditions. The specifications as contained in this document are the minimum NPA requirements. Vendor to take design responsibility & ensure correct specifications.



FURNITURE SPECIFICATIONS



TABLE: 1200 Round 4 Seat Code:NPA-TABLE-M-4

Draft



Typical 1200mm diameter
4 Seater Meeting Table

FINISH



Vancouver Maple CDL

PIC	NO #	DESCRIPTION
	2x	1200 Dia. Half Top
	2x	ECO LEG (E) Finish: SaddleWood Matt
	2x	STANDARD LEG (S) Finish: SaddleWood Matt
	2x	VARIABLE CONNECTOR

CAD Furniture Symbol:

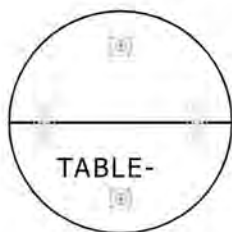

CODE Description

TABLE	M	4
CATEGORY	TYPE	SEATER

Barcode:

NPA issued barcode to be fixed under top before delivery to site.

TECHNICAL INFORMATION

- Dimensions:** 1200mm diameter x 752mm high.
- Tabletop:** Table from 2 "D-End" tops from 32mm thick tabletop substrate from high-density particle board with surface of 0.6mm Decon CDL. Tops to be pre-drilled and fitted with metal grommets to accommodate a M6x16 allen screw (5mm Allen Key). All parts not exposed / visible to get 0.2mm brown backer.
- Finishes:** Top to be in Vancouver Maple CDL with 2mm maple finish flat edge high impact edging.
- Table Legs:** ECO and Standard Legs to be finished in SaddleWood Matt powder coated application. Non centre thread bolt type - sleeve thread only.
- Supplier:** Plasticised sticker fixed out of sight, stating: Supplier, physical address and contact details.
- Warranty & Design:** All units to carry a minimum 5 year warranty under normal office environment conditions. The specifications as contained in this document are the minimum NPA requirements. Vendor to take design responsibility & ensure correct specifications.



FURNITURE SPECIFICATIONS



Draft

TABLE: 1500 Round 6 Seat Code:NPA-TABLE-M-6



FINISH



Vancouver Maple CDL

PIC	NO #	DESCRIPTION
	2x	1500 Dia. Half Top
	2x	ECO LEG (E) Finish: SaddleWood Matt
	2x	STANDARD LEG (S) Finish: SaddleWood Matt
	3x	VARIABLE CONNECTOR

CAD Furniture Symbol:

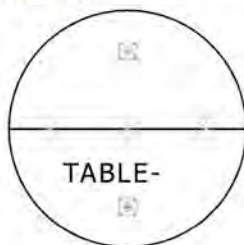

CODE Description

TABLE	M	6
CATEGORY	TYPE	SEATER

Barcode:

NPA issued barcode to be fixed under top before delivery to site.

TECHNICAL INFORMATION

Dimensions: 1500mm diameter x 752mm high.
Tabletop: Table from 2 "D-End" tops from 32mm thick tabletop substrate from high-density particle board with surface of 0.6mm Decon CDL. Tops to be pre-drilled and fitted with metal grommets to accommodate a M6x16 allen screw (5mm Allen Key). All parts not exposed / visible to get 0.2mm brown backer.

Finishes: Top to be in Vancouver Maple CDL with 2mm maple finish flat edge high impact edging.
Table Legs: ECO and Standard Legs to be finished in SaddleWood Matt powder coated application. Non centre thread bolt type - sleeve thread only.

Supplier: Plasticised sticker fixed out of sight, stating: Supplier, physical address and contact details.
Warranty & Design: All units to carry a minimum 5 year warranty under normal office environment conditions. The specifications as contained in this document are the minimum NPA requirements. Vendor to take design responsibility & ensure correct specifications.



Draft

MAIL CENTRE PAYMENTS TROLLEY: Code: NPA-TROLLEY-MA-1



Barcode:

NPA issued barcode to be fixed to front before delivery to site.

CODE Description

TROLLEY	MA	1
CATEGORY	DEPARTMENT	UNIT

TECHNICAL DATA:

Dimensions: Height: Approx. 1100mm
Width: Approx. 620mm
Depth: Approx. 680mm

Description: Mail Centre Payments Trolley, manufactured from mild steel tube approx. 20mm Dia. All metal to be powder coated, Col. Ivory. Trolley to accommodate 3 tiers. Top two tiers to accommodate each a mild steel 2,5mm nominal thickness, money box of approx. size, 600 x 660 mm. Money box must be provided with latch to accommodate a padlock. Money box to be powder coated in dark blue colour.

Bottom tier provided with powder coated mesh basket with mesh size approx 50 x 25mm.

Trolley to be provided with rubber castors of approx. 100mm Dia on swivel action. Bumper disks to be provided at castor fix to prevent wall damage.

Push handle to be provided similar to shopping trolley handles.

Utilization: This trolley is used in the payments section specifically to transport payments received from the mail centre to the payments section and cashier.

Supplier: Plasticised sticker fixed out of view stating: Supplier's name, physical address and contact details.

Warranty: Five years warranty under heavy duty Mail Room conditions years. The specifications as contained in this document are the minimum NPA requirements. Vendor to take design responsibility & ensure correct specifications. System designed to manufacturers details. Manufacturer to state warranty and max carrying capacity.



TROLLEYS



GENERAL TROLLEY: Code: NPA-TROLLEY-G

Draft



Barcode:

NPA issued barcode to be fixed to front before delivery to site.

CODE Description

TROLLEY **G**

CATEGORY

DEPARTMENT

TECHNICAL DATA:

Dimensions: Height: Approx. 1100mm
Width: Approx. 1000mm
Depth: Approx. 680mm

Description: Trolley to be manufactured from 20mm mild steel tube or similar, bend at the top ends to accommodate a top shelf over the entire trolley length. All metal to be powder coated Col. Ivory. The horizontal tube frame also forming the push handle. The trolley is provided with 1,5mm mild steel shelves. The shelves are also powder coated in Grey colour.

Trolley to be provided with rubber castors of approximately 100mm diameter, with swivel action on the front and fixed at the push end. Bumper disks to be provided at castor fix to prevent wall damage.

Utilization: This trolley is used for all general applications.

Supplier: Plasticised sticker fixed out of view stating: Supplier's name, physical address and contact details.

Warranty: Five years warranty under heavy duty Mail Room conditions years. The specifications as contained in this document are the minimum NPA requirements. Vendor to take design responsibility & ensure correct specifications. System designed to manufacturers details. Manufacturer to state warranty and max carrying capacity.



MAIL CENTRE TROLLEY: Code: NPA-TROLLEY-MA-2

Draft



Barcode:

NPA issued barcode to be fixed to front before delivery to site.

CODE Description

TROLLEY	MA	2
CATEGORY	DEPARTMENT	UNIT

TECHNICAL DATA:

Dimensions: Height: Approx. 1100mm
Width: Approx. 620mm
Depth: Approx. 680mm

Description: Mail Centre Trolley, manufactured from mild steel tube approx. 20mm Dia. All metal to be powder coated, Col. Ivory. Trolley to accommodate 3 tiers. Top two tiers accommodate Linvar "large" bin. Colour Yellow. Linvar bin must be provided with 2 (Two) dividers. The bin must be separated into three equal sections by means of dividers/partitions, to prevent the open envelopes from falling over.

Bottom tier provided with powder coated mesh basket with mesh size approx 50 x 25mm.

Trolley to be provided with rubber castors of approx. 100mm (dia) on swivel action. Bumper disks to be provided at castor fix to prevent wall damage.

Push handles to be provided similar to shopping trolley handles.

Utilization: This trolley will be used to transfer the open envelopes from the Letter opener machine to the sorting tables. The "bins" (containers), 2x to be included, must be able to hold A4 envelopes (375L x420W x 180H)

Supplier: Plasticised sticker fixed out of view, stating: Supplier's name, physical address and contact details.

Warranty: Five years warranty under heavy duty Mail Room conditions years. The specifications as contained in this document are the minimum NPA requirements. Vendor to take design responsibility & ensure correct specifications. System designed to manufacturers details. Manufacturer to state warranty and max carrying capacity.



PROCESSING TROLLEY: Code: NPA-TROLLEY-P

Draft



Barcode:

NPA issued barcode to be fixed to front before delivery to site.

CODE Description

TROLLEY **P**

CATEGORY

DEPARTMENT

TECHNICAL DATA:

Dimensions: Height: Approx. 1100mm
Width: Approx. 1000mm
Depth: Approx. 680mm

Description: Trolley to be manufactured from 20mm mild steel tube, bend at the top ends to accommodate a top shelf over the entire trolley length. All metal to be powder coated Col. Ivory. The horizontal tube frame also forming the push handle. The trolley is provided with 1,5mm mild steel inserts, divided equally into 3 tiers. The inserts are also powder coated and sloped at approx 45 Deg from front to back. The insert is again fitted at an angle of approx. 15 deg to prevent files from falling out.

The trolley top is provided with a 16mm melamine top in Maple colour. The melamine is recessed to allow 5mm surround from the tube frame.

Trolley to be provided with rubber castors of approx. 100mm Dia, with swivel action on the front and fixed at the push end. Bumper disks to be provided at castor fix to prevent wall damage.

Utilization: This trolley is used in the following areas: Post processing (Assessment Maintenance, Accounts Maintenance); Registration (Portfolio Maintenance). Mainly to transport A4 files between processing units.

Supplier: Plasticised sticker fixed out of view stating: Supplier's name, physical address and contact details.

Warranty: Five years warranty under heavy duty Mail Room conditions years. The specifications as contained in this document are the minimum NPA requirements. Vendor to take design responsibility & ensure correct specifications. System designed to manufacturers details. Manufacturer to state warranty and max carrying capacity.



TEA TROLLEY:

Code: NPA-TROLLEY-G-T

Draft



Barcode:

NPA issued barcode to be fixed to front before delivery to site.

CODE Description

TROLLEY	G	T
CATEGORY	DEPARTMENT	DESCRIPTION.

TECHNICAL DATA:

Dimensions: Height (FLOOR TO TOP TIER INCL CASTORS): 750mm
Width: 450mm
Length: 650mm

Description: Trolley to be manufactured from 25x25mm mild steel square tube welded to rigid structure. Corners and joints welded flush and seamless. Steel frame finished in "saddlewood" powder coating. Steel frame to receive fitted 16mm Maple top and bottom tiers as well as 2x drawers on full extension runners. Runners to have "self lock" device to remain closed during maneuvering. NOTE: Maple to be CDL except for executive application to be veneer. 1x Drawer to have cutlery tray. Bottom tier to have 5mm stainless steel rods rail.

Castors and Handles: Trolley to be provided with rubber castors of approximately 100mm diameter, with swivel action on the front and fixed at the push end. Castors to be soft rubber for maximum insulation. Drawer handles to be 110mm saddlewood finish.

Utilization: This trolley is used for all areas Kitchen and Pause area tea trolleys

Supplier: Plasticised sticker fixed out of view stating: Supplier's name, physical address and contact details.

Warranty: Five years warranty under heavy duty Mail Room conditions years. The specifications as contained in this document are the minimum NPA requirements. Vendor to take design responsibility & ensure correct specifications. System designed to manufacturers details. Manufacturer to state warranty and max carrying capacity.



OFFICE ACCESSORIES



Draft

MAGNETIC WHITE BOARD Code: NPA-WB-2000-1200

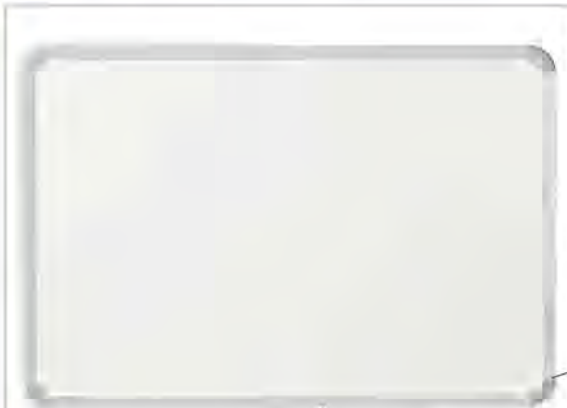

Standard Frame
20mm wide

MANUFACTURER: PARROT PRODUCTS
or similar or equal
PRODUCT: Magnetic white board
PRODUCT CODE: BD0970
SIZE: 2000 x 1200



Concealed
mounting

CODE Description

WB	2000	1200
CATEGORY	WIDTH	HEIGHT

Barcode:

NPA issued barcode to be fixed
to frame before delivery to site.

<http://www.parrotproducts.biz>
(Manufacturers home page)
or similar or equal

DESCRIPTION:

Wall hung magnetic white board including:

- Concealed fixing brackets
- White Board "Start-up" kit (4x Whiteboard markers,
1x Whiteboard eraser, 1x Whiteboard cleaner)

SIZE:

2000 x 1200

FRAME:

Natural Anodized Aluminium

SUPPLIER:

Plasticised sticker fixed out of sight, stating supplier, physical address
and contact details.

WARRANTY & DESIGN:

All units to carry a minimum 5 year warranty under normal office
environment conditions. The specifications as contained in this
document are the minimum NPA requirements. Vendor to take design
responsibility and ensure correct specifications.



OFFICE ACCESSORIES



Draft

MAGNETIC WHITE BOARD Code: NPA-WB-900-900



Standard Frame
20mm wide

MANUFACTURER: PARROT PRODUCTS
or similar or equal
PRODUCT: Magnetic white board
PRODUCT CODE: BD0928
SIZE: 900 x 900



Concealed
mounting

CODE Description

WB	900	900
CATEGORY	WIDTH	HEIGHT

Barcode:

NPA issued barcode to be fixed
to frame before delivery to site.

<http://www.parrotproducts.biz>
(Manufacturers home page)
or similar or equal

DESCRIPTION:

Wall hung magnetic white board including:

- Concealed fixing brackets
- White Board "Start-up" kit (4x Whiteboard markers, 1x Whiteboard eraser, 1x Whiteboard cleaner)

SIZE:

900 x 900

FRAME:

Natural Anodized Aluminium

SUPPLIER:

Plasticised sticker fixed out of sight, stating supplier, physical address and contact details.

WARRANTY & DESIGN:

All units to carry a minimum 5 year warranty under normal office environment conditions. The specifications as contained in this document are the minimum NPA requirements. Vendor to take design responsibility and ensure correct specifications.



OFFICE ACCESSORIES



Draft

MAGNETIC WHITE BOARD Code: NPA-WB-1200-1000

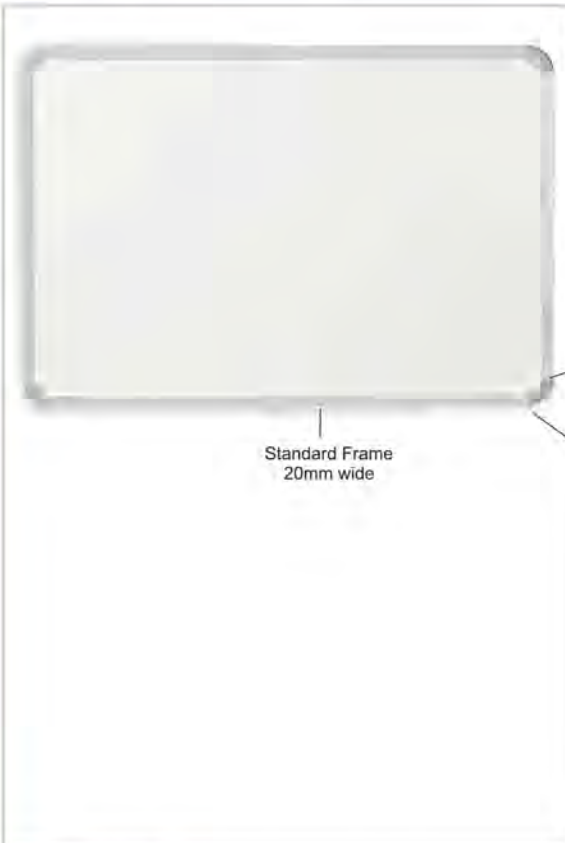

Standard Frame
20mm wide

MANUFACTURER: PARROT PRODUCTS
or similar or equal
PRODUCT: Magnetic white board
PRODUCT CODE: BD0948
SIZE: 1200 x 1000



Concealed
mounting

CODE Description		
WB	1200	1000
CATEGORY	WIDTH	HEIGHT

Barcode:

NPA issued barcode to be fixed
to frame before delivery to site.

<http://www.parrotproducts.biz>
(Manufacturers home page)
or similar or equal

DESCRIPTION:

Wall hung magnetic white board including:

- Concealed fixing brackets
- White Board "Start-up" kit (4x Whiteboard markers,
1x Whiteboard eraser, 1x Whiteboard cleaner)

SIZE:

1200 x 1000

FRAME:

Natural Anodized Aluminium

SUPPLIER:

Plasticised sticker fixed out of sight, stating supplier, physical address
and contact details.

WARRANTY & DESIGN:

All units to carry a minimum 5 year warranty under normal office
environment conditions. The specifications as contained in this
document are the minimum NPA requirements. Vendor to take design
responsibility and ensure correct specifications.



OFFICE ACCESSORIES



Draft

MAGNETIC WHITE BOARD Code: NPA-WB-1500-1200



Standard Frame
20mm wide

MANUFACTURER: PARROT PRODUCTS
or similar or equal
PRODUCT: Magnetic white board
PRODUCT CODE: BD0960
SIZE: 1500 x 1200



Concealed
mounting

CODE Description

WB	1500	1200
CATEGORY	WIDTH	HEIGHT

Barcode:

NPA issued barcode to be fixed
to frame before delivery to site.

<http://www.parrotproducts.biz>
(Manufacturers home page)
or similar or equal

DESCRIPTION:

Wall hung magnetic white board including:

- Concealed fixing brackets
- White Board "Start-up" kit (4x Whiteboard markers,
1x Whiteboard eraser, 1x Whiteboard cleaner)

SIZE:

1500 x 1200

FRAME:

Natural Anodized Aluminium

SUPPLIER:

Plasticised sticker fixed out of sight, stating supplier, physical address
and contact details.

WARRANTY & DESIGN:

All units to carry a minimum 5 year warranty under normal office envi-
ronment conditions. The specifications as contained in this document
are the minimum NPA requirements. Vendor to take design responsi-
bility and ensure correct specifications.



OFFICE ACCESSORIES



Draft

MAGNETIC WHITE BOARD Code: NPA-WB-900-600

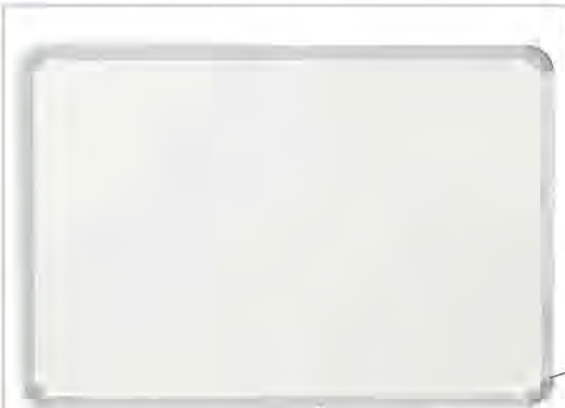

Standard Frame
20mm wide

MANUFACTURER: PARROT PRODUCTS
or similar or equal
PRODUCT: Magnetic white board
PRODUCT CODE: BD0925
SIZE: 900 x 600



Concealed
mounting

CODE Description

WB	900	600
CATEGORY	WIDTH	HEIGHT

Barcode:

NPA issued barcode to be fixed
to frame before delivery to site.

<http://www.parrotproducts.biz>
(Manufacturers home page)
or similar or equal

DESCRIPTION:

Wall hung magnetic white board including:

- Concealed fixing brackets
- White Board "Start-up" kit (4x Whiteboard markers, 1x Whiteboard eraser, 1x Whiteboard cleaner)

SIZE:

900 x 600

FRAME:

Natural Anodized Aluminium

SUPPLIER:

Plasticised sticker fixed out of sight, stating supplier, physical address and contact details.

WARRANTY & DESIGN:

All units to carry a minimum 5 year warranty under normal office environment conditions. The specifications as contained in this document are the minimum NPA requirements. Vendor to take design responsibility and ensure correct specifications.



FURNITURE SPECIFICATIONS



Draft

3 WAY CLUSTER

Code:NPA-WS-CLUS-600-1200-600-3

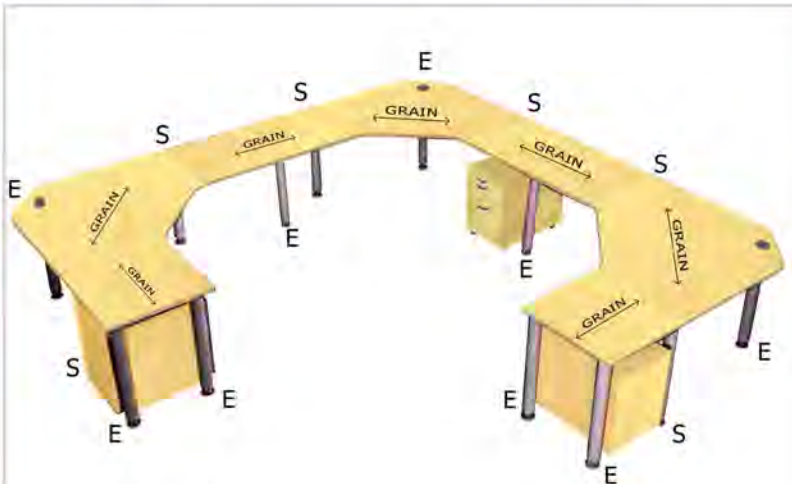

Typical 3 WAY CLUSTER

FINISH



Vancouver Maple CDL

PIC	NO#	DESCRIPTION
	3x	STD CORE 1200 x 1200 x 650
	2x	TOP 600w x 650d
	2x	TOP 1200w x 650d
	7x	ECO LEG (E) Finish: SaddleWood Matt
	6x	STANDARD LEG (S) Finish: SaddleWood Matt
	12x	VARIABLE CONNECTOR
	3x	MOBILE PEDESTAL NPA FC-MP
	6x	SNAIK -1000mm long
	3x	CMS03 Cable Outlet
	4x	OPTIONAL STEEL MODESTY PANEL. Finish: SaddleWood Matt

CAD Furniture Symbol:

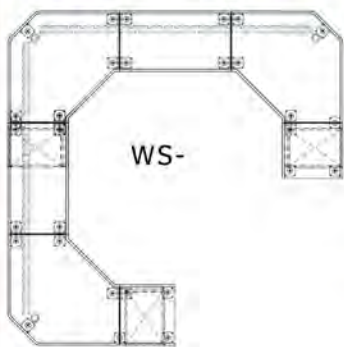

CODE Description

WS	CLUS	600	1200	600	3
CATEGORY	DESC	TOP	TOP	TOP	NO OF WS's

Barcode:

NPA issued barcode to be fixed under top before delivery to site.

TECHNICAL INFORMATION

- Description:** A typical "NPA WS- CLUS-3" 3 way clerical cluster including mobile pedestals is manufactured to the same specifications as 3x NPA WS-600-600-L/R's, but the centre joining sections are 2 single 1200 instead of 4X 600's.
- Manufacturer:** The ordering, manufacturer and supply of a "NPA WS-CLUS-3" must be read, manufactured and delivered in strict conjunction with NPA standards item "NPA WS-600-600".
- Table Legs:** Positioning of legs on a cluster NPA WS-CLUS-3 is according to Picture above (See E and S).
- Pedestal:** Pedestals as per catalog. NPA FC-MP included as standard part of this workstation.
- Supplier:** Plasticised sticker fixed out of sight stating: Supplier, physical address and contact details.
- Warranty & Design:** All units to carry a minimum 5 year warranty under normal office environment conditions. The specifications as contained in this document are the minimum NPA requirements. Vendor to take design responsibility & ensure correct specifications.



FURNITURE SPECIFICATIONS



Draft

CLERICAL Workstation Code: NPA-WS-600-600-L/R

Typical Clerical Work Station

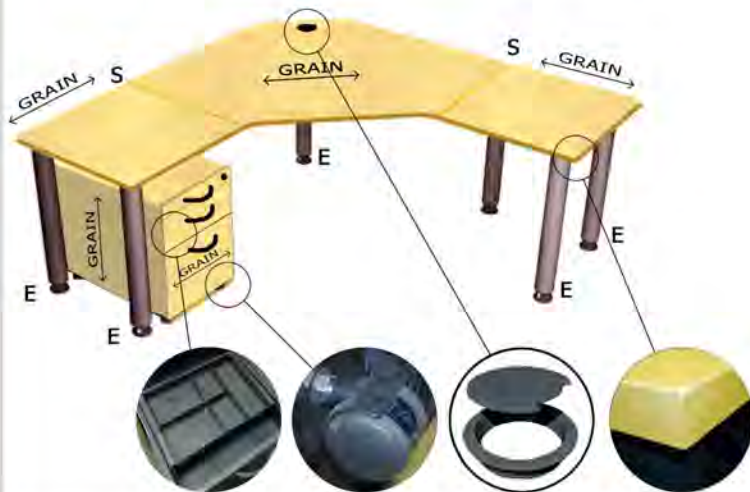

FINISH



Vancouver Maple CDL

CAD Furniture Symbol:

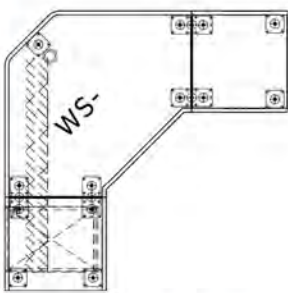

CODE Description

WS	600	600	L/R
CATEGORY	TOP	TOP	PEDESTAL LOCATION

Barcode:

NPA issued barcode to be fixed under top before delivery to site.

PIC	NO#	DESCRIPTION
	1x	STD CORE 1200 x 1200 x 650
	2x	TOP 600w x 650d
	5x	ECO LEG (E) Finish: SaddleWood Matt
	2x	STANDARD LEG (S) Finish: SaddleWood Matt
	4x	VARIABLE CONNECTOR
	1x	MOBILE PEDESTAL NPA FC-MP
	1.5x	SNAIK -1000mm long
	2x	OPTIONAL STEEL MODESTY PANEL. Finish: SaddleWood Matt

TECHNICAL INFORMATION

- Dimensions:** 1800mm x 1800mm x 752mm high.
- Worktop:** 32mm thick worktop substrate from high-density particle board with surface of 0.6mm Decon CDL. All tops to be pre-drilled and fitted with metal grommets to accommodate a M6x16 allen screw (5mm Allen Key). All parts not exposed / visible to get 0.2mm brown backer.
- Reticulation:** CDS Plastics 'CMS03' 80mm Charcoal cable outlet positioned as per drawing. 1500mm long CDS Plastics "SNAIK" tray to underside of desk top as per drawing position.
- Finishes:** Top to be in Vancouver Maple CDL with 2mm maple finish flat edge high impact edging.
- Table Legs:** ECO and Standard Legs to be finished in SaddleWood Matt powder coated application. Non centre thread bolt type - sleeve thread only.
- Pedestal:** Pedestal as per standard. NPA FC-MP included as standard part of this workstation.
- Supplier:** Plasticised sticker fixed out of sight, stating: Supplier, physical address and contact details.
- Warranty & Design:** All units to carry a minimum 5 year warranty under normal office environment conditions. The specifications as contained in this document are the minimum NPA requirements. Vendor to take design responsibility & ensure correct specifications.



FURNITURE SPECIFICATIONS



Draft

2 WAY CLUSTER

Code:NPA-WS-CLUS-600-1200-600-2

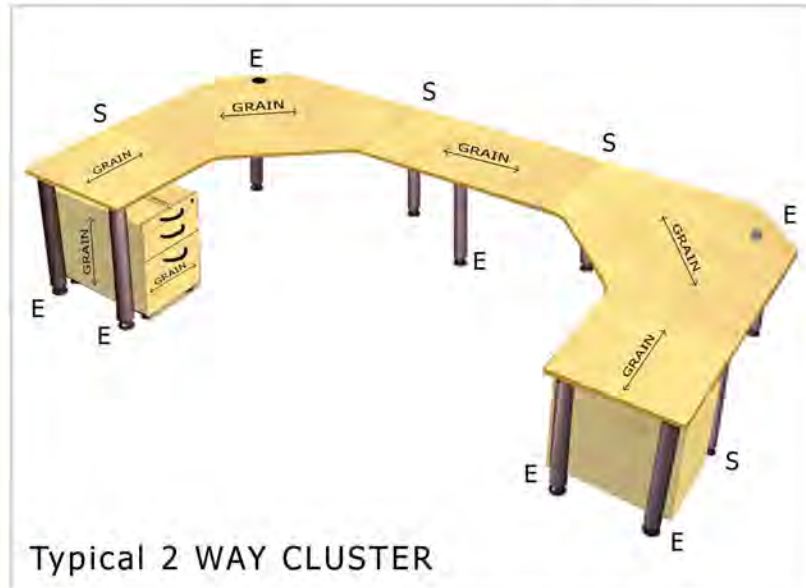

FINISH



Vancouver Maple CDL

PIC	NO#	DESCRIPTION
	2x	STD CORE 1200 x 1200 x 650
	2x	TOP 600w x 650d
	1x	TOP 1200w x 650d
	7x	ECO LEG (E) Finish: SaddleWood Matt
	4x	STANDARD LEG (S) Finish: SaddleWood Matt
	6x	VARIABLE CONNECTOR
	2x	MOBILE PEDESTAL NPA FC-MP
	4x	SNAIK -1000mm long
	2x	CMS03 Cable Outlet
	2x	OPTIONAL STEEL MODESTY PANEL. Finish: SaddleWood Matt

CAD Furniture Symbol:

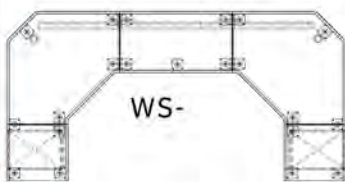

CODE Description

WS	CLUS	600	1200	600	2
CATEGORY	DESCRIPTION	TOP	TOP	TOP	NO OF WS'S

Barcode:

NPA issued barcode to be fixed under top before delivery to site.

TECHNICAL INFORMATION

- Description:** A typical "NPA WS-CLUS-2" 2 way clerical cluster including mobile pedestals is manufactured to the same specifications as 2x NPA WS-600-600-L/R's, but the centre joining section is a single 1200 instead of 2x 600's.
- Manufacturer:** The ordering, manufacturer and supply of a "NPA WS-CLUS-2" must be read, manufactured and delivered in strict conjunction with NPA Standards item "NPA WS-600-600-L/R".
- Table Legs:** Positioning of legs on a cluster NPA WS- CLUS-2 is according to Picture above (See E and S).
- Pedestal:** Pedestals as per standards NPA FC-MP included as standard part of this workstation.
- Supplier:** Plasticized sticker fixed out of sight stating: Supplier, physical address and contact details.
- Warranty & Design:** All units to carry a minimum 5 year warranty under normal office environment conditions. The specifications as contained in this document are the minimum NPA requirements. Vendor to take design responsibility & ensure correct specifications.



FURNITURE SPECIFICATIONS



Draft

EXEC Support Workstation Code: NPA-WS-S-EX-L/R



FINISH



Vancouver Maple CDL

PIC	NO#	DESCRIPTION
	1x	TOP 1150w x 700d
	1x	TOP 700w x 700d
	1x	STD CORE 1200w x 1200d
	4x	VARIABLE CONNECTOR
	3x	ECO LEG (E) Finish: SaddleWood Matt
	1x	STANDARD LEG (S) Finish: SaddleWood Matt
	1x	FIXED PEDESTAL NPA FC-EFP
	2,5x	SNAIK -1000mm long
	2x	STEEL MODESTY PANEL. Finish: SaddleWood Matt

CAD Furniture Symbol:

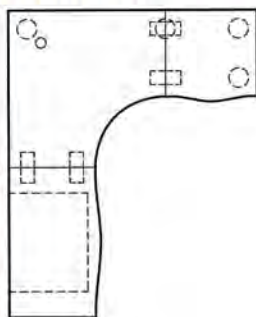

CODE Description

WS	S	EX	L/R
CATEGORY	DESCRIPTION	DEPARTMENT	LEFT/RIGHT HANDED

Barcode:

NPA issued barcode to be fixed under top before delivery to site.

TECHNICAL INFORMATION

- Dimensions:** 2350mm x 1900mm x 752mm high.
- Worktop:** Worktop from 32mm high-density particle board with 0,6mm Vancouver Maple CDL surface,
- Finish:** Top to be in Vancouver Maple CDL with Saddlewood bullnose to curved front & 2mm high impact Saddlewood edging with straight joints to all other sides. . All parts not exposed / visible to get 0.2mm brown backer.
- Table Legs:** ECO and Standard Legs to be finished in SaddleWood Matt powder coated application. Non centre thread bolt type - sleeve thread only..
- Reticulation:** CDS Plastics 'CMS03' 80mm Charcoal cable outlet positioned as per drawing. 2500mm long CDS Plastics "SNAIK" tray to underside of desk top as per drawing position.
- Pedestal:** Pedestal as per standard. NPA FC-EFP included as standard part of this workstation.
- Supplier:** Plasticised sticker fixed out of sight, stating: Supplier, physical address and contact details.
- Warranty & Design:** All units to carry a minimum 5 year Warranty under normal office environment conditions. The specifications as contained in this document are the minimum NPA requirements. Vendor to take design responsibility & ensure correct specifications.



FURNITURE SPECIFICATIONS



Draft

EXECUTIVE Workstation Code: NPA-WS-EX-L/R

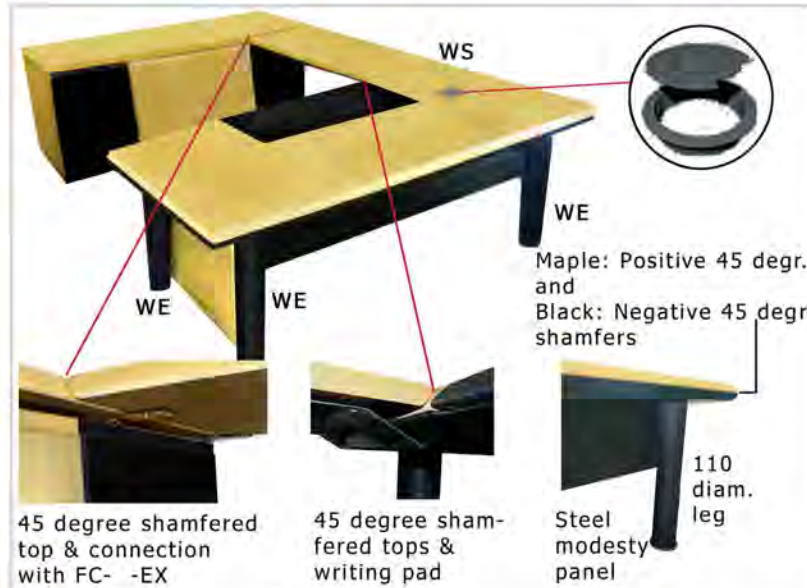

FINISH



Vancouver Maple Veneer

	1x	STD CORE 2000 x 900
	1x	TOP 1310w x 500d
	1x	WIDE (110diam.) STD type LEG (WS) Finish: SaddleWood Matt
	3x	WIDE (110diam.) ECO type LEG (WE) Finish: SaddleWood Matt
	5x	VARIABLE CONNECTOR
	1x	CREDENZA NPA FC-CR-EX
	1x	MOBILE PEDESTAL NPA FC-MP-EX
	1.5x	SNAIK -1000mm long
	2x	STEEL MODESTY PANEL. Finish: SaddleWood Matt

Executives Only Level 14 UP

CAD Furniture Symbol:

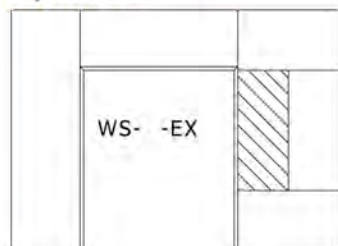

CODE Description

WS	EX	L/R
CATEGORY	DEPARTMENT	LEFT/RIGHT

Barcode:

NPA issued barcode to be fixed under top before delivery to site.

W/S TOPS

Dimensions: 2750mm x 2000mm x 752mm high.

Worktop: Substrate from high-density particle board, Top: 32mm, all other components 16mm. All with 0,7mm Vancouver Maple veneer surface. All parts not exposed / visible to get 0.2mm brown backer.

Edging: Chamfered edges: Solid Maple at 45 degrees. Square edges: 2,5mm solid Vancouver Maple edging with straight joints.

Finish: VENEER: First Coat sanding sealer, Fill board and sand down, Second Coat sanding sealer, Sand down, Apply colour if applicable, 3x Coats "Chemspec" or similar or equal product thinners based High Gloss varnish with A-C catalyst, sprayed on. Allow to dry between coats.

Reticulation: BLACK: Spray paint Satin sheen Duco.

Table Legs: CDS Plastics 'CMS03' 80mm Charcoal cable outlet positioned as per drawing. 1500mm long CDS Plastics "SNAIK" tray to underside of desk top as per drawing position.

Pedestal: 110 diameter, similar to ECO and Standard Legs, to be finished in SaddleWood Matt powder coated application. Non centre thread bolt type - sleeve thread only.

Credenza: Pedestal as per catalog. NPA FC-MP-EX included as standard part of this workstation.

Supplier: Credenza as per catalog. NPA FC-CR-EX included as standard part of this workstation.

Warranty & Design: Plasticised sticker fixed out of sight, stating: Supplier, physical address and contact details.

All units to carry a minimum 5 year Warranty under normal office environment conditions. The specifications as contained in this document are the minimum NPA requirements. Vendor to take design responsibility & ensure correct specifications.



FURNITURE SPECIFICATIONS



Draft

Oversized Workstation Code: NPA-WS-600-1200-L/R

Oversized 1200x600 WorkStation

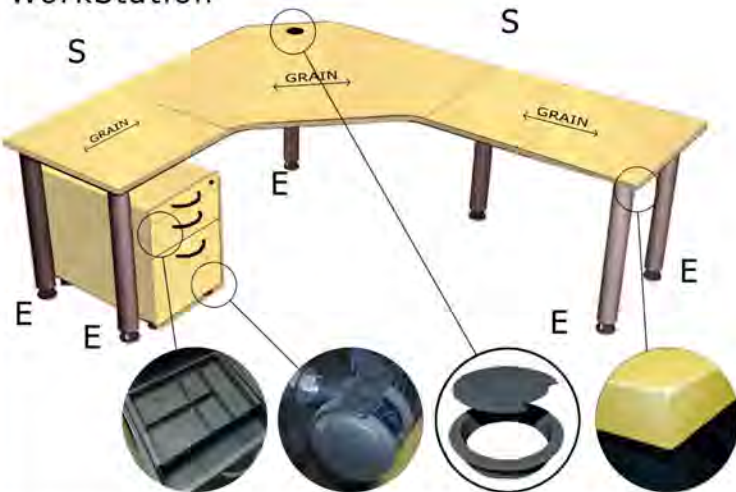

FINISH



Vancouver Maple CDL

PIC	NO#	DESCRIPTION
	1x	STD CORE 1200 x 1200 x 650
	1x	TOP 600w x 650d
	1x	TOP 1200w x 650d
	5x	ECO LEG (E) Finish: SaddleWood Matt
	2x	STANDARD LEG (S) Finish: SaddleWood Matt
	4x	VARIABLE CONNECTOR
	1x	MOBILE PEDESTAL NPA FC-MP
	2x	SNAIK -1000mm long
	2x	OPTIONAL STEEL MODESTY PANEL. Finish: SaddleWood Matt

CAD Furniture Symbol:

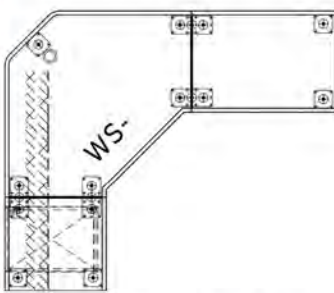

CODE Description

WS	600	1200	L/R
CATEGORY	TOP	TOP	PEDISTAL LOCATION

Barcode:

NPA issued barcode to be fixed under top before delivery to site.

TECHNICAL INFORMATION

- Dimensions:** 1800mm x 2100mm x 752mm high.
- Worktop:** 32mm thick worktop substrate from high-density particle board with surface of 0.6mm Decon CDL. All tops to be pre-drilled and fitted with metal grommets to accommodate a M6x16 allen screw (5mm Allen Key). All parts not exposed / visible to get 0.2mm brown backer.
- Reticulation:** CDS Plastics 'CMS03' 80mm Charcoal cable outlet positioned as per drawing. 2000mm long CDS Plastics "SNAIK" tray to underside of desk top as per drawing position.
- Finishes:** Top to be in Vancouver Maple CDL with 2mm maple finish flat edge high impact edging.
- Table Legs:** ECO and Standard Legs to be finished in SaddleWood Matt powder coated application. Non centre thread bolt type - sleeve thread only.
- Pedestal:** Pedestal as per catalog. NPA FC-MP included as standard part of this workstation.
- Supplier:** Plasticised sticker fixed out of sight, stating: Supplier, physical address and contact details.
- Warranty & Design:** All units to carry a minimum 5 year warranty under normal office environment conditions. The specifications as contained in this document are the minimum NPA requirements. Vendor to take design responsibility & ensure correct specifications.

