

Bangle  
Four(4) bangles need to be fitted to the shield equally spaced.

Shield

NB: Stopper Block MUST be fitted with a 5mm gap between shield and stopper block as shown on the sketch.

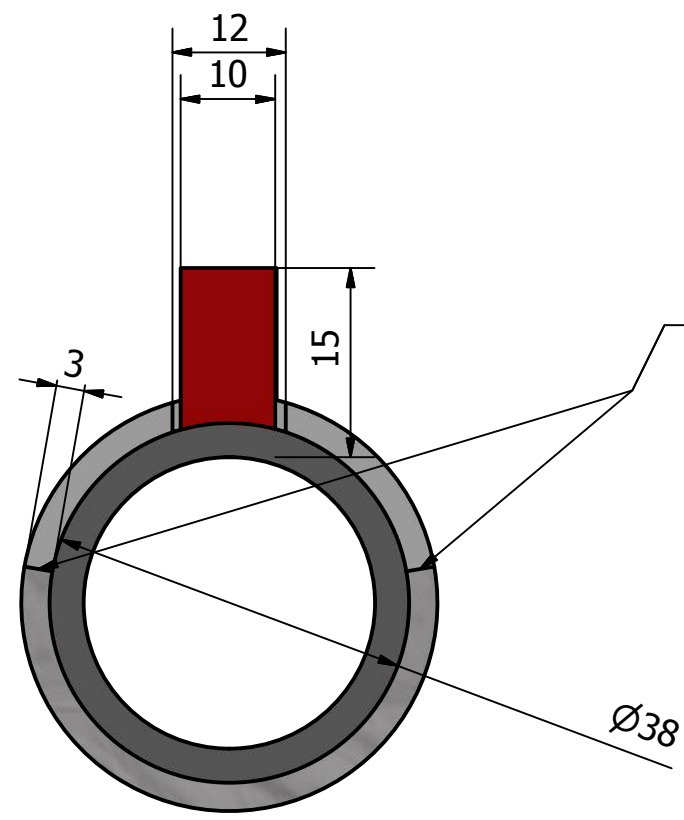
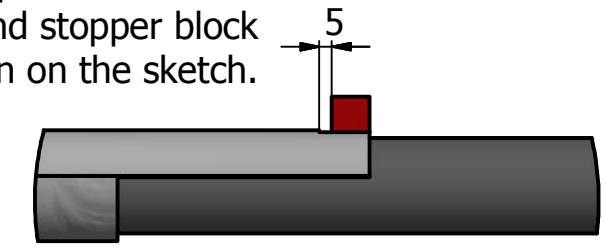

Welding to be a full Penetration weld between shield and bangle on both sides of the bangle.

NB: The bangle needs to be fitted at least 100mm from the edge of the shield.

The shield has to face the soot blower perpendicular.

**THIS DRAWING IS NOT TO BE USED FOR MANUFACTURING**

ELEMENT#	TUBE#	REV NO:
160	8	A

ESKOM DWG REF:

THIS DRAWING IS THE PROPERTY OF ESKOM. IT MAY ONLY BE ALTERED BY THE CARAB TEKNIVA GROUP. CONTROLLED REVISIONS ARE ADMINISTERED BY CARAB TEKNIVA GROUP.

SHT.NO	SIZE
1	A3

DRAWN BY:	Wilhelm du Toit	2016/03/01
CHECKED BY:		
APPROVED BY:		

TITLE:  
SH2 2.6m x Tube 38mm OD - Shield  
  
TUTUKA POWER STATION  
SCALE: N.T.S  
CARAB DWG NO:



CARAB

MAT COLOUR	MAT FLOW #	STOCK NO	MATERIAL	O/D	WT	MIN 't	DESCRIPTION
	NA	NA	310 SS	44	3	NA	Shield
	NA	NA	13CrMo44	NA	NA	NA	NA