



REQUEST FOR QUOTATION (RFQ) FOR RENTAL OF MOBILE PORTABLE ABLUSION SERVICES FOR A PERIOD OF 24 MONTHS (2 YEARS)

Reference Number	IZIKO-RFQ-CSM-NMPH-ABUTION 21/05/2026/R
Description	RENTAL OF MOBILE PORTABLE ABLUSION SERVICES
Address	Iziko South African Museum 25 Queen Victoria Street Cape Town 8001
Attention	Kagiso Themba
Site Visit	Not Compulsory (but advisable via appointment with technical rep)
Advert Date	21 May 2026
Closing Date and Time for Submission	17 June 2026 11h00am
Method of Delivery	Quotes / Proposals, and accompanying documentation, must be emailed to SCM scm@iziko.org.za; kthemba@iziko.org.za;
Technical Enquiries	Frederick Paynter Direct Line: 021 481 3800 fpaynter@iziko.org.za , scm@iziko.org.za ;
Name of Company	
CSD Supplier Number (MA.....Number)	
B-BBEE Status Level of Contribution	
Quote Price (Incl. VAT)	
Signature	

BIDDER'S DISCLOSURE (SBD 4)

1. PURPOSE OF THE FORM (SBD 4)

Any person (natural or juristic) may make an offer or offers in terms of this invitation to bid. In line with the principles of transparency, accountability, impartiality, and ethics as enshrined in the Constitution of the Republic of South Africa and further expressed in various pieces of legislation, it is required for the bidder to make this declaration in respect of the details required hereunder.

Where a person/s are listed in the Register for Tender Defaulters and / or the List of Restricted Suppliers, that person will automatically be disqualified from the bid process.

2. BIDDER'S DECLARATION

2.1. Is the bidder, or any of its directors / trustees / shareholder / members / partners or any person having a controlling interest¹ in the enterprise, employed by the state?
YES/NO

2.1.1. If so, furnish particulars of the names, individual identity numbers, and, if applicable, state employee numbers of sole proprietor/ directors / trustees / shareholders / members/ partners or any person having a controlling interest in the enterprise, in table below.

Full Name	Identity Number	Name of State Institution

2.2. Do you, or any person connected with the bidder, have a relationship with any person who is employed by the procuring institution?

YES/NO

2.2.1. If so, furnish particulars:

.....
.....

2.3. Does the bidder or any of its directors / trustees / shareholders / members / partners or any person having a controlling interest in the enterprise have any interest in any other related enterprise whether or not they are bidding for this contract?

YES/NO

¹ the power, by one person or a group of persons holding the majority of the equity of an enterprise, alternatively, the person/s having the deciding vote or power to influence or to direct the course and decisions of the enterprise.

2.3.1. If so, furnish particulars:

.....
.....

3. DECLARATION

I, the undersigned, (name) in submitting the accompanying bid, do hereby make the following statements that I certify to be true and complete in every respect:

- 3.1. I have read and I understand the contents of this disclosure;
- 3.2. I understand that the accompanying bid will be disqualified if this disclosure is found not to be true and complete in every respect;
- 3.2. The bidder has arrived at the accompanying bid independently from, and without consultation, communication, agreement, or arrangement with any competitor. However, communication between partners in a joint venture or consortium² will not be construed as collusive bidding.
- 3.3. In addition, there have been no consultations, communications, agreements or arrangements with any competitor regarding the quality, quantity, specifications, prices, including methods, factors or formulas used to calculate prices, market allocation, the intention or decision to submit or not to submit the bid, bidding with the intention not to win the bid and conditions or delivery particulars of the products or services to which this bid invitation relates.
- 3.4. The terms of the accompanying bid have not been, and will not be, disclosed by the bidder, directly or indirectly, to any competitor, prior to the date and time of the official bid opening or of the awarding of the contract.
- 3.5. There have been no consultations, communications, agreements or arrangements made by the bidder with any official of the procuring institution in relation to this procurement process prior to and during the bidding process except to provide clarification on the bid submitted where so required by the institution; and the bidder was not involved in the drafting of the specifications or terms of reference for this bid.
- 3.6. I am aware that, in addition and without prejudice to any other remedy provided to combat any restrictive practices related to bids and contracts, bids that are suspicious will be reported to the Competition Commission for investigation and possible imposition of administrative penalties in terms of section 59 of the Competition Act No 89 of 1998 and or may be reported to the National Prosecuting Authority (NPA) for criminal investigation and or may be restricted from conducting business with the public sector for a period not exceeding ten (10) years in terms of the Prevention and Combating of Corrupt Activities Act No 12 of 2004 or any other applicable legislation.

I CERTIFY THAT THE INFORMATION FURNISHED IN PARAGRAPHS 1, 2 and 3 ABOVE IS CORRECT.

I ACCEPT THAT THE STATE MAY REJECT THE BID OR ACT AGAINST ME IN TERMS OF PARAGRAPH 6 OF PFMA SCM INSTRUCTION 03 OF 2021/22 ON PREVENTING AND COMBATING ABUSE IN THE SUPPLY CHAIN MANAGEMENT SYSTEM SHOULD THIS DECLARATION PROVE TO BE FALSE.

.....
Signature

.....
Date

² Joint venture or Consortium means an association of persons for the purpose of combining their expertise, property, capital, efforts, skill and knowledge in an activity for the execution of a contract.

.....
Position

.....
Name of bidder (Company Name)

(SBD 6.1)

PREFERENCE POINTS CLAIM FORM IN TERMS OF THE PREFERENTIAL PROCUREMENT REGULATIONS 2022

This preference form must form part of all tenders invited. It contains general information and serves as a claim form for preference points for specific goals.

NB: BEFORE COMPLETING THIS FORM, TENDERERS MUST STUDY THE GENERAL CONDITIONS, DEFINITIONS AND DIRECTIVES APPLICABLE IN RESPECT OF THE TENDER AND PREFERENTIAL PROCUREMENT REGULATIONS, 2022

1. GENERAL CONDITIONS

- 1.1. The following preference point systems are applicable to invitations to tender:
- the 80/20 system for requirements with a Rand value of up to R50 000 000 (all applicable taxes included); and
 - the 90/10 system for requirements with a Rand value above R50 000 000 (all applicable taxes included).
- 1.2. **To be completed by the organ of state**
The applicable preference point system for this tender is the **80/20** preference point system.
- 1.3. Points for this tender (even in the case of a tender for income-generating contracts) shall be awarded for:
- (a) Price: and
 - (b) Specific Goals
- 1.4. **To be completed by the organ of state:**

The maximum points for this tender are allocated as follows:

	POINTS
PRICE	80
SPECIFIC GOALS	20
Total points for Price and SPECIFIC GOALS	100

- 1.5. Failure on the part of a tenderer to submit proof or documentation required in terms of this tender to claim points for specific goals with the tender, will be interpreted to mean that preference points for specific goals are not claimed.
- 1.6. The organ of state reserves the right to require of a tenderer, either before a tender is adjudicated or at any time subsequently, to substantiate any claim in regard to preferences, in any manner required by the organ of state.

2. DEFINITIONS

- (a) **tender** means a written offer in the form determined by an organ of state in response to an invitation to provide goods or services through price quotations, competitive tendering process or any other method envisaged in legislation;
- (b) **price** means an amount of money tendered for goods or services, and includes all applicable

- taxes less all unconditional discounts;
- (c) **“rand value”** means the total estimated value of a contract in Rand, calculated at the time of bid invitation, and includes all applicable taxes;
- (d) **“tender for income-generating contracts”** means a written offer in the form determined by an organ of state in response to an invitation for the origination of income-generating contracts through any method envisaged in legislation that will result in a legal agreement between the organ of state and a third party that produces revenue for the organ of state, and includes, but is not limited to, leasing and disposal of assets and concession contracts, excluding direct sales and disposal of assets through public auctions; and
- (e) **“The Act”** means the Preferential Procurement Policy Framework Act, 2000 (Act No. 5 of 2000).

3. FORMULAE FOR PROCUREMENT OF GOODS AND SERVICES

3.1. POINTS AWARDED FOR PRICE

3.1.1. THE 80/20 OR 90/10 PREFERENCE POINT SYSTEMS

A maximum of 80 or 90 points is allocated for price on the following basis:

$$P_s = 80 \left(1 - \frac{P_t - P_{min}}{P_{min}} \right) \quad \text{or} \quad P_s = 90 \left(1 - \frac{P_t - P_{min}}{P_{min}} \right)$$

Where:

P_s = Points scored for price of tender under consideration

P_t = Price of tender under consideration

P_{min} = Price of lowest acceptable tender

3.2. FORMULAE FOR DISPOSAL OR LEASING OF STATE ASSETS AND INCOME GENERATING PROCUREMENT

3.2.1. POINTS AWARDED FOR PRICE

A maximum of 80 or 90 points is allocated for price on the following basis:

$$P_s = 80 \left(1 - \frac{P_t - P_{max}}{P_{max}} \right) \quad \text{or} \quad P_s = 90 \left(1 - \frac{P_t - P_{max}}{P_{max}} \right)$$

Where:

P_s = Points scored for price of tender under consideration

P_t = Price of tender under consideration

P_{max} = Price of highest acceptable tender

4. POINTS AWARDED FOR SPECIFIC GOALS

- 4.1. In terms of Regulation 4(2); 5(2); 6(2) and 7(2) of the Preferential Procurement Regulations, preference points must be awarded for specific goals stated in the tender. For the purposes of this tender the tenderer will be allocated points based on the goals stated in table 1 below as may be supported by proof/documentation stated in the conditions of this tender;
- 4.2. In cases where organs of state intend to use Regulation 3(2) of the Regulations, which states that, if it is unclear whether the 80/20 or 90/10 preference point system applies, an organ of state must, in the tender documents, stipulate in the case of –

- (a) an invitation for tender for income-generating contracts, that either the 80/20 or 90/10 preference point system will apply and that the highest acceptable tender will be used to determine the applicable preference point system; or
- (b) any other invitation for tender, that either the 80/20 or 90/10 preference point system will apply and that the lowest acceptable tender will be used to determine the applicable preference point system,

then the organ of state must indicate the points allocated for specific goals for both the 90/10 and 80/20 preference point system.

Table 1: Specific goals for the tender and points claimed are indicated per the table below.
 (Note to organs of state: Where either the 90/10 or 80/20 preference point system is applicable, corresponding points must also be indicated as such.
 Note to tenderers: The tenderer must indicate how they claim points for each preference point system.)

The specific goals allocated points in terms of this tender	Evidence	Number of points allocated (80/20 system) (To be completed by the organ of state)	Number of points claimed (80/20 system) (To be completed by the tenderer)
Persons, or categories of persons, historically disadvantaged- (HDI) by unfair discrimination on the basis of	<ul style="list-style-type: none"> Proof of B-BBEE certificate; Company Registration Certification Identification Documentation. CSD report 		
Race: Black persons (ownership)* 50% or more black ownership = 20 points Less than 50% black ownership = 10 points 0% black ownership = 0 points			

DECLARATION WITH REGARD TO COMPANY/FIRM

4.3. Name of company/firm:

4.4. Company Registration number:

4.5. TYPE OF COMPANY/FIRM

- Partnership/Joint Venture / Consortium
- One-person business/sole propriety

- Public Company
- Personal Liability Company
- (Pty) Limited
- Non-Profit Company
- State Owned Company

[TICK APPLICABLE BOX]

4.6. I, the undersigned, who is duly authorised to do so on behalf of the company/firm, certify that the points claimed, based on the specific goals as advised in the tender, qualifies the company/ firm for the preference(s) shown and I acknowledge that:

- i) The information furnished is true and correct;
- ii) The preference points claimed are in accordance with the General Conditions as indicated in paragraph 1 of this form;
- iii) In the event of a contract being awarded as a result of points claimed as shown in paragraphs 1.4 and 4.2, the contractor may be required to furnish documentary proof to the satisfaction of the organ of state that the claims are correct;
- iv) If the specific goals have been claimed or obtained on a fraudulent basis or any of the conditions of contract have not been fulfilled, the organ of state may, in addition to any other remedy it may have –
 - (a) disqualify the person from the tendering process;
 - (b) recover costs, losses, or damages it has incurred or suffered as a result of that person's conduct;
 - (c) cancel the contract and claim any damages which it has suffered as a result of having to make less favourable arrangements due to such cancellation;
 - (d) recommend that the tenderer or contractor, its shareholders and directors, or only the shareholders and directors who acted on a fraudulent basis, be restricted from obtaining business from any organ of state for a period not exceeding 10 years, after the *audi alteram partem* (hear the other side) rule has been applied; and
 - (e) forward the matter for criminal prosecution, if deemed necessary

.....
SIGNATURE(S) OF TENDERER(S)

SURNAME AND NAME:

DATE:

ADDRESS:

REQUEST FOR QUOTATION (RFQ) FOR RENTAL OF MOBILE PORTABLE ABLUSION SERVICES FOR A PERIOD OF 24 MONTHS (2 YEARS)

1. BACKGROUND IZIKO

Iziko Museums of South Africa (Iziko) is a schedule 3A public entity and non-profit organisation, partly subsidised by the National Department of Sport, Arts & Culture (DSAC), bringing together 12 national museums and a Social History Centre situated in the Western Cape under a single governance and leadership structure. Iziko was established in terms of the Cultural Institutions Act, 1998 (Act No. 119 of 1998) and is required to comply with the Public Finance Management Act (PFMA), 1999 (Act No. 1 of 1999, as amended) and its concomitant Regulations.

2. OVERVIEW

The Iziko Museums of South Africa intends to source and procure, Mobile Portable Ablution toilets and servicing of the ablation equipment to use at our site, located at Klein Drakenstein Paarl, Schuurmansfontein Road, Iziko Mandela Prison House rented for a period of 24 months (2 years)

3. SPECIFICATION

A series of serviced chemical toilets are required at the above-mentioned site. This service must:

Scope of works:

- Supply female toilet facilities similar or equivalent to those indicated in **Annexure A**, Figure 1 or 3, providing a minimum of 5 individual toilets (cubicles) in total. The configuration of units is at the *supplier's discretion*.
- Supply male toilet facilities similar or equivalent to those indicated in **Annexure A** Figure 2 or 3, providing a minimum of 2 individual toilets (cubicles) and 3 urinals in total. The configuration of units (including urinals) is at the supplier's discretion.
- Supply 1 accessible (paraplegic) male toilet.
- Supply 1 accessible (paraplegic) female toilet.
- All toilets to have lighting capability.
- Include delivery to site and full installation/setup of all units.
- Include weekly servicing, including cleaning and waste removal.

4. PERIOD

Toilets are expected to remain on site for a period of up to 24 months; please provide a monthly rental rate. A provision should be made for a cancellation notice period of 2 months is to apply.

5. SITE:

Iziko Nelson Mandela Prison House, Klein Drakenstein Paarl, Schuurmansfontein Road.

Annexure A

Figure 1 – Female ablutions

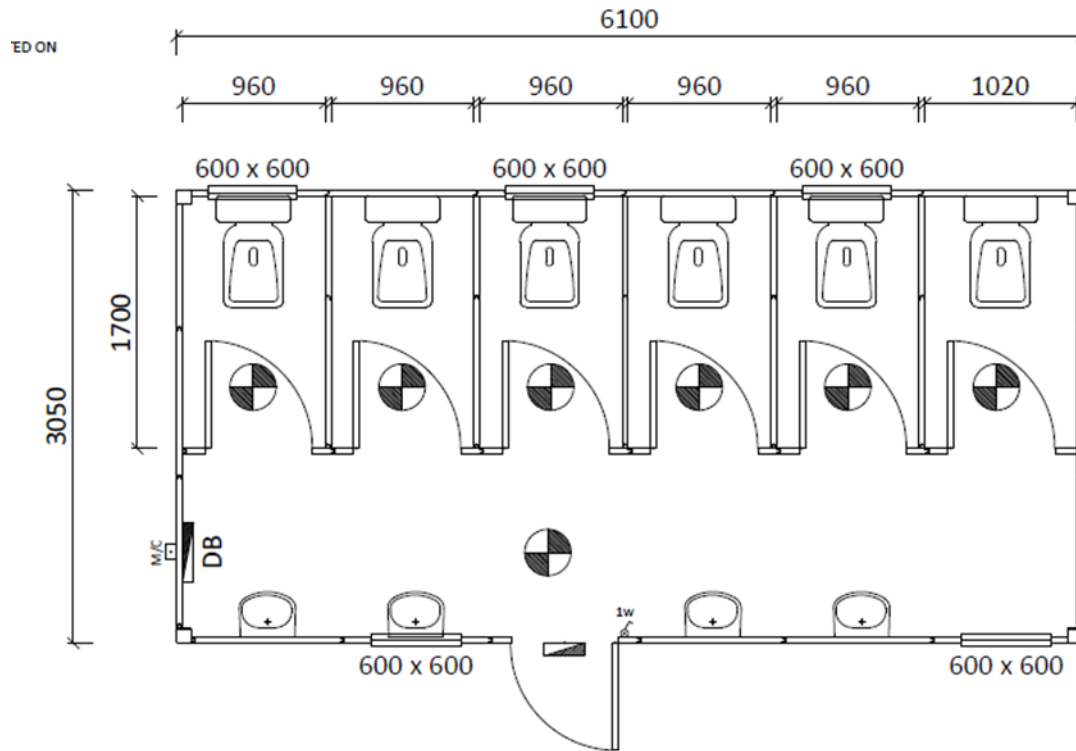

Figure 2 – Male ablutions

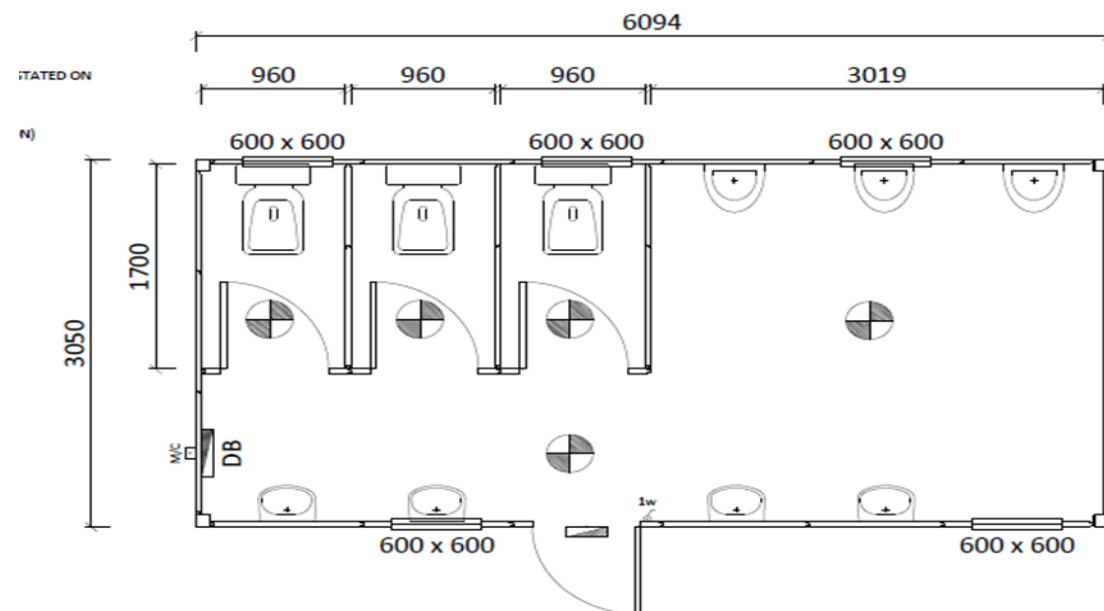
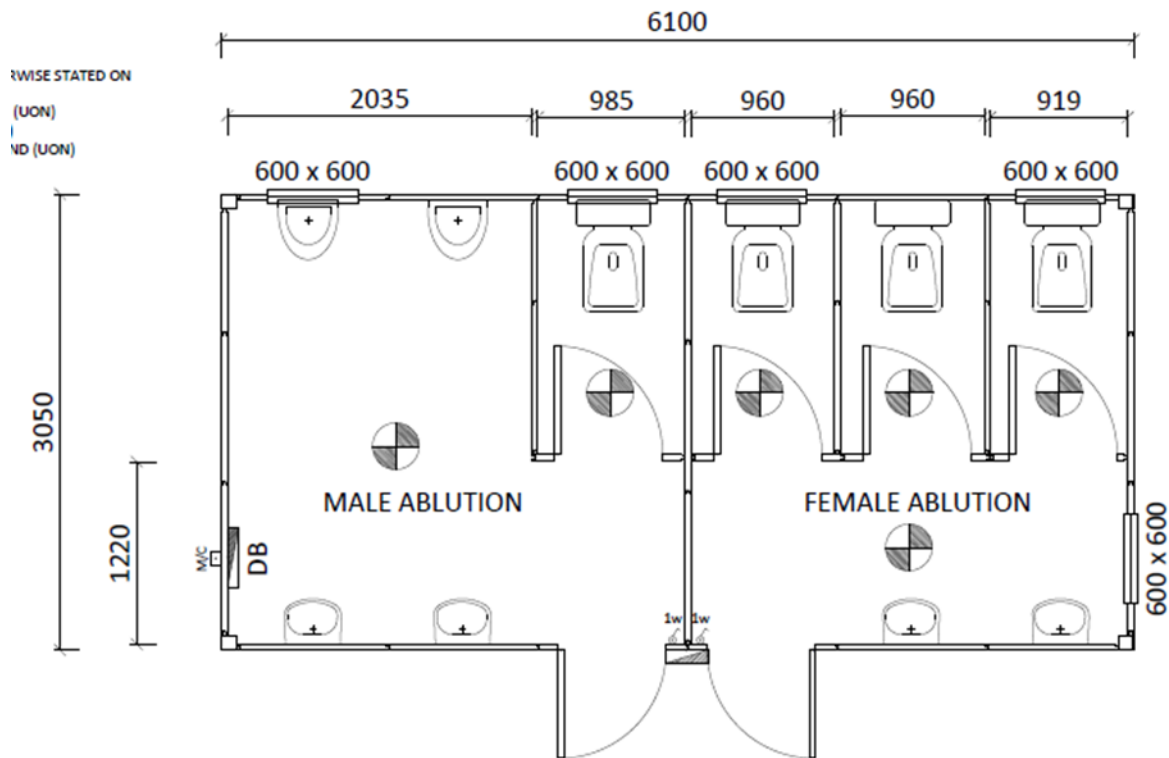

Figure 3 – Shared (Male and Female) ablutions



6. ADMINISTRATIVE DOCUMENTS

Service Providers must submit all documents as outlined in Table below.

1	Central Supplier Database Report – with supplier number and company details (www.csd.gov.za) and Tax Status Verification Pin together with tax registration number
2	Detailed pricing structure on your company letterhead: A cost schedule detailing full cost breakdown, inclusive of VAT, any disbursement, and escalations, if applicable, etc.
3	A Valid B-BBEE Certificate or Sworn Affidavit to determine the Service provider’s status level.
4	Signed Request for Quotation Document
5	Experience : Minimum 5 clients reference letters not older than 5 years

Note: Failure to supply any of the administrative documents stipulated may lead to the quote not being considered.

7. EVALUATION CRITERIA

Iziko promotes the concept of “best value” in the award of contracts, as opposed to merely looking for the cheapest price, which does not necessarily provide the best value. Best value

incorporates the expertise, experience and technical proposal of the organisation and individuals who will be providing the service and the organisational capacity supporting the project team.

Iziko is committed to achieving Government's transformation objectives in terms of the Preferential Procurement Policy Framework Act.

8. PREFERENTIAL POINTS

Proposals will be evaluated on the 80/20 preference points scoring system: that is, 80% of the points awarded will be based on price, as indicated in the table below; and 20% of the points awarded will be based on specific goals, allocated as indicated in the table below:

	Specific goals allocated points	Price
Total maximum points	20	80

9. PRICING SCHEDULE

Description (Please see specification)	Unit	Qty	Year 1	Year 2
Rental of portable toilets service for a period of 24 Months (two years)	Monthly	12	R	R
Sub -Total (monthly rental x 12 months)			R	R
Add Vat @15%			R	R
Total			R	R
Grand Total (Year 1 + Year 2)			R	

Pricing Instruction

1. Payment will be made based on the deliverables for the goods received.
2. Payment will only be made on the basis of work completed satisfactorily, and invoices provided and approved by the project manager.
3. Quotes to be valid for 90 days from the bid closing date.

Please Note: a formal detailed quotation to be sent with proposal. The pricing schedule above and formal quotation must include all applicable costs and there can be no variation after award has been made.

10. FORMAL CONTRACT

- a) The proposal and appended documentation read together form the basis for an agreement to be negotiated and concluded in a formal contract between Iziko and the preferred Service Provider

- b) A mere offer and acceptance shall not constitute a formal contract of any nature for any purpose between Iziko and the preferred Service Provider/s.

11. GENERAL PRINCIPLES

- (a) The lowest or only quotation received will not necessarily be accepted.
(b) Iziko and its Council reserves the right to accept or reject any quotation in response to the Request to Quote and to withdraw its decision to seek the provision of these services at any time.

12. DECLARATION

The undersigned, who warrants that he / she is duly authorized to do so on behalf of the enterprise:

- i) confirms that neither the name of the enterprise or the name of any partner, manager, director, or other person, who wholly or partly exercises, or may exercise, control over the enterprise appears on the Register of Tender Defaulters established in terms of the Prevention and Combating of Corrupt Activities Act of 2004;
- ii) confirms that no partner, member, director, or other person, who wholly or partly exercises, or may exercise, control over the enterprise appears, has within the last five years been convicted of fraud or corruption;
- iii) confirms that I / we are not associated, linked, or involved with any other tendering entities submitting tender offers and have no other relationship with any of the tenderers or those responsible for compiling the scope of work that could cause or be interpreted as a conflict of interest; and;
- iv) confirms that the contents of these questionnaire/forms (SBD 4, & 6.1) are within my personal knowledge and are to the best of my belief both true and correct;
- v) accept that, in addition to cancellation of a contract, action may be taken against me should the Declaration prove to be false.

Signed _____ Date _____
Name _____ Position _____
Enterprise name _____

Please note that if the supporting documentation is not provided then the submission will be classified as non-responsive.

1. Disqualification

Please note that if a bid document is not filled in correctly or completely, or complied with the specification, or is delivered/send after the bid closing date and time, or the supplier is not registered on the CSD or supplier has a non-compliant tax status, then unfortunately that bidder maybe disqualified. Please return this document with the supporting documents.

2. Bid Document Submission

Emailed tender documents will be accepted. However, the onus is on the tenderer to ensure that complete email documents have been received by the IZIKO by the due date and time. Please note that any alterations to the tender document other than filling in the tenderer's details and tender price will automatically disqualify the tenderer.