

1 2 3 4 5 6 7 8 9 10 11 12 13 14 15 16

A
B
C
D
E
F
G
H
J
K
L
M

A
B
C
D
E
F
G
H
J
K
L
M
REVISION 0
SHEET 1 OF 6
MASTER FILED UNDER 0.52/30549

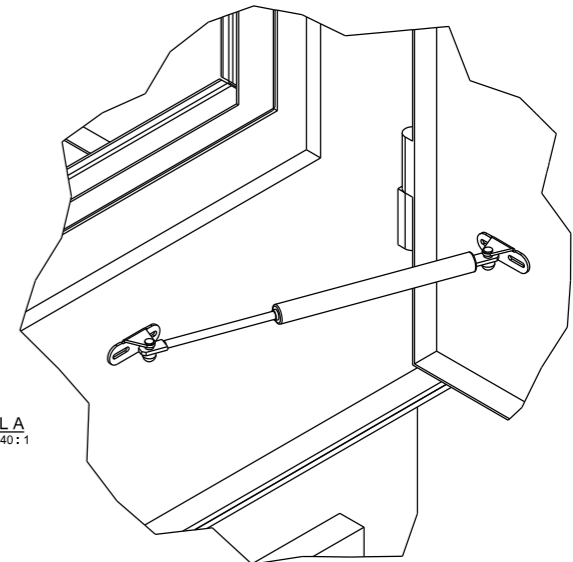
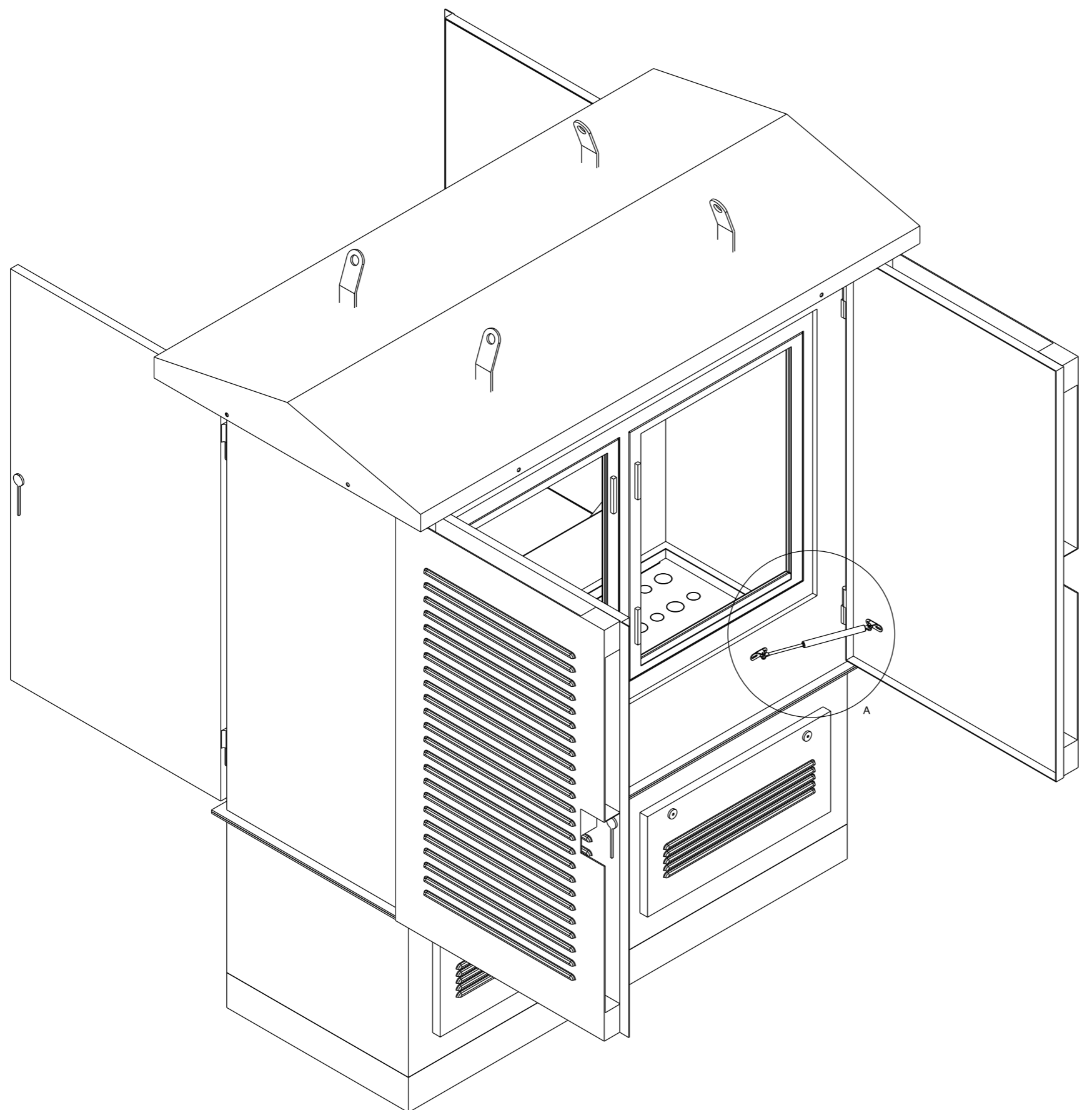

DETAIL A
SCALE 0.40:1

REV	DESCRIPTION	BY	CHKD	APP	DATE
1	NEW SHEETS ADDED	M.W	V.KP		FEB 2021
	REVISION TO MASTER				

SIVTEK / VITHALE

REV	REVISION DESCRIPTION	BY	CHKD	APP	DATE
	PROJECT APPROVED BY: DESIGN ACCEPTED BY: S.J. VAN ZYL				
	DATE: 30/10/2017			Eskom Holdings SOC Ltd Reg No 2002/015527/30	
	PROJECT CHECKED BY: DESIGN APPROVED BY:				
	DATE:	© JB ARRANGEMENT			
	PROJECT DRAWN BY: DESIGN CHECKED BY:				
	DATE:				
	SCALE 1:10	DESIGN DRAWN BY: M. MURALI			
	DATE: 30/10/2017				
				SHEET NUMBER	REVISION
				1	0

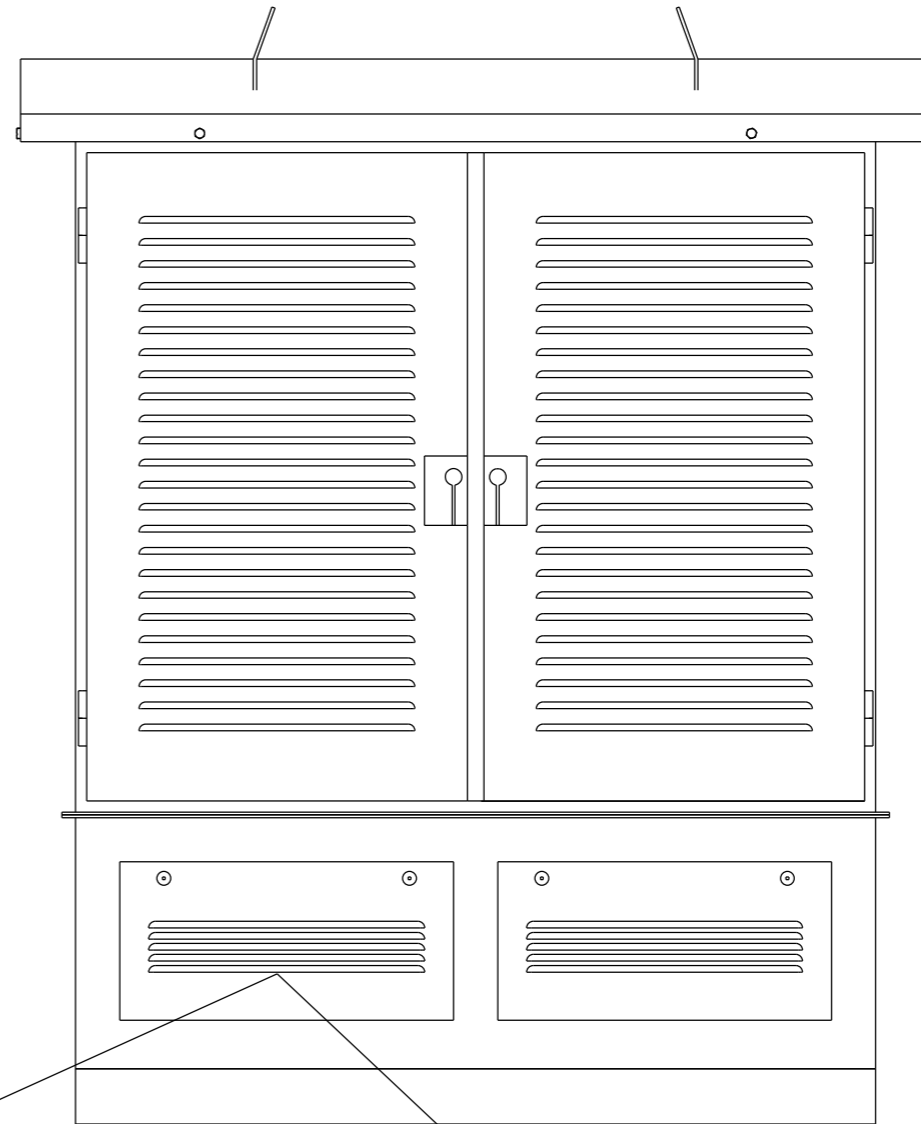
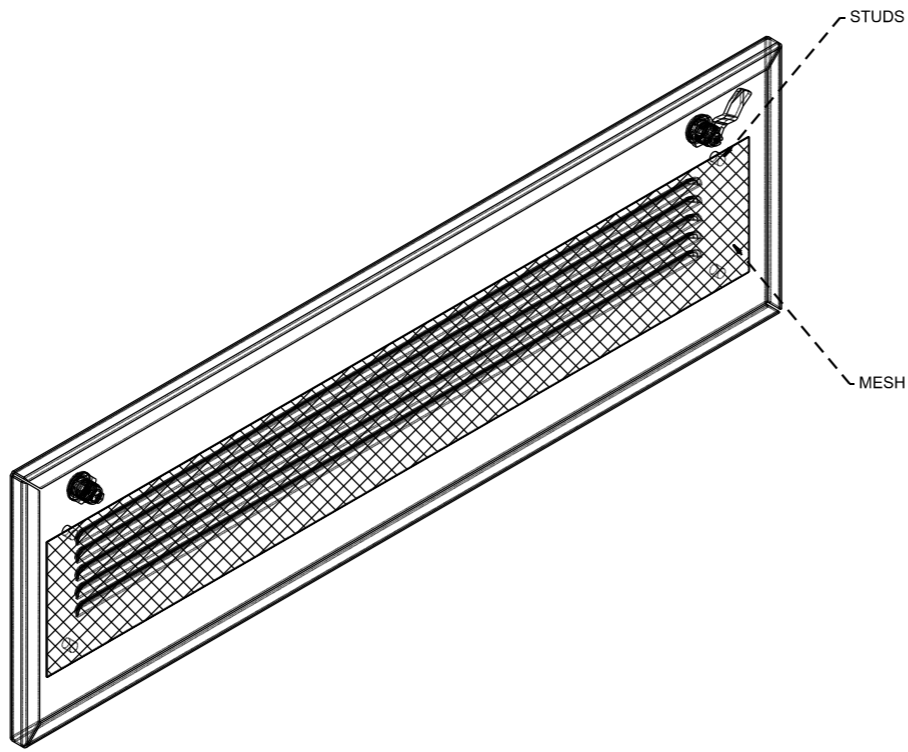

FRONT VIEW
SCALE 1:6

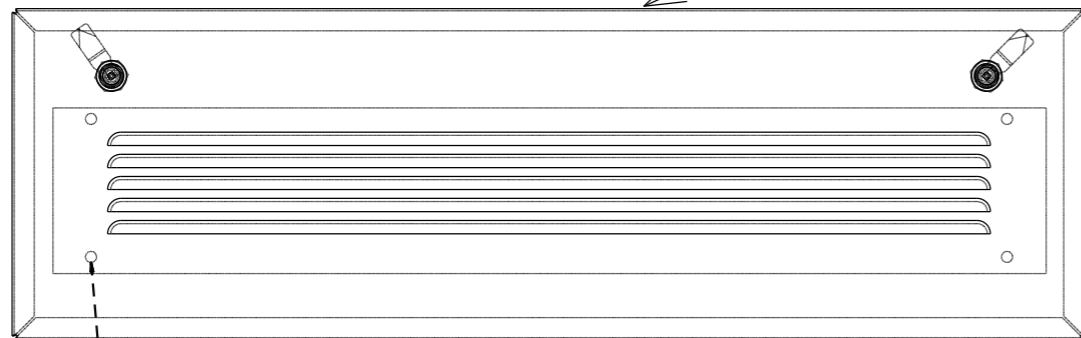

- STUDS AND WING NUTS

FRONT VIEW
SCALE 1:3

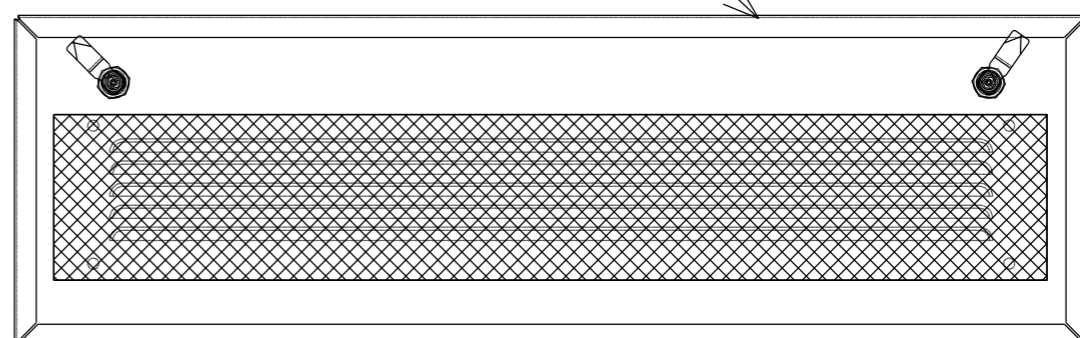

REAR VIEW
SCALE 1:3

REV	DESCRIPTION	BY	CHKD	APP	DATE
1	NEW SHEETS ADDED	M.M	V.KP		FEB 2021
	REVISION TO MASTER				

SIVTEK / VITHALE

REV	REVISION DESCRIPTION	BY	CHKD	APP	DATE
	PROJECT APPROVED BY: DESIGN ACCEPTED BY: S.J. VAN ZYL				
	DATE: 30/10/2017			Eskom Holdings SOC Ltd Reg No 2002/015527/30	
	PROJECT CHECKED BY: DESIGN APPROVED BY:				
	DATE: DATE:				
	PROJECT DRAWN BY: DESIGN CHECKED BY:				
	DATE: DATE:				
	SCALE 1:10	DESIGN DRAWN BY: M. MURALI			
	DATE: 30/10/2017			SHEET NUMBER	REVISION
				2	0

FRONT VIEW

FRONT VIEW OUTER DOORS REMOVED
18U SWINGFRAME

FRONT VIEW OUTER DOORS
AND SWING FRAME REMOVED

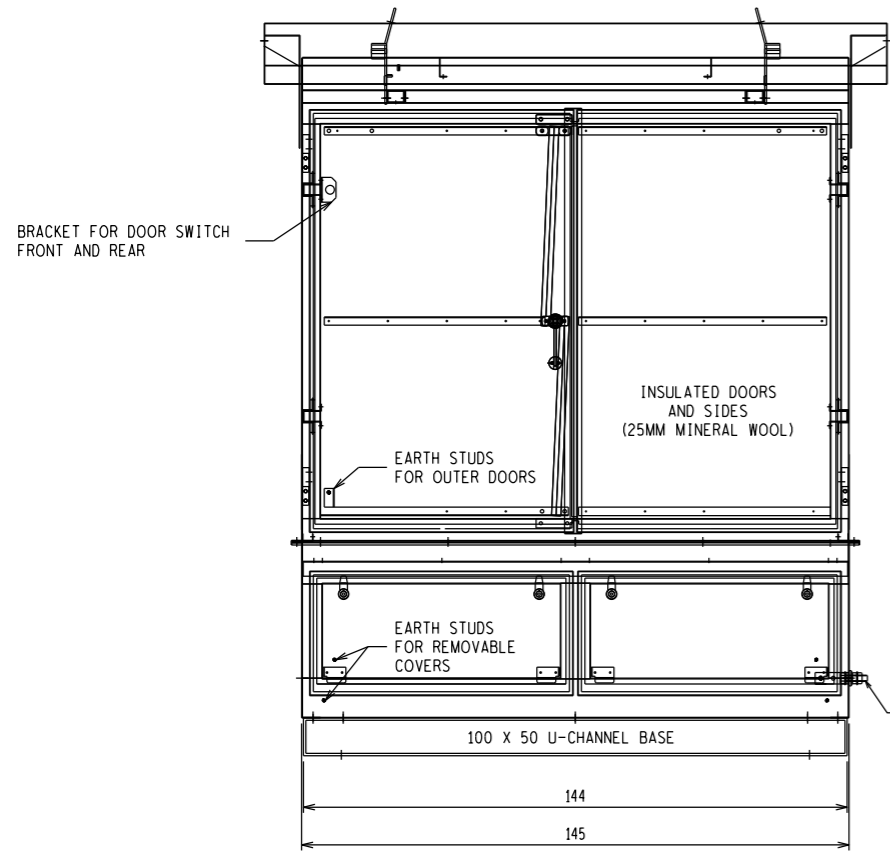

EARTH STUDS FOR
OUTER DOORS

M16 BRASS STUD

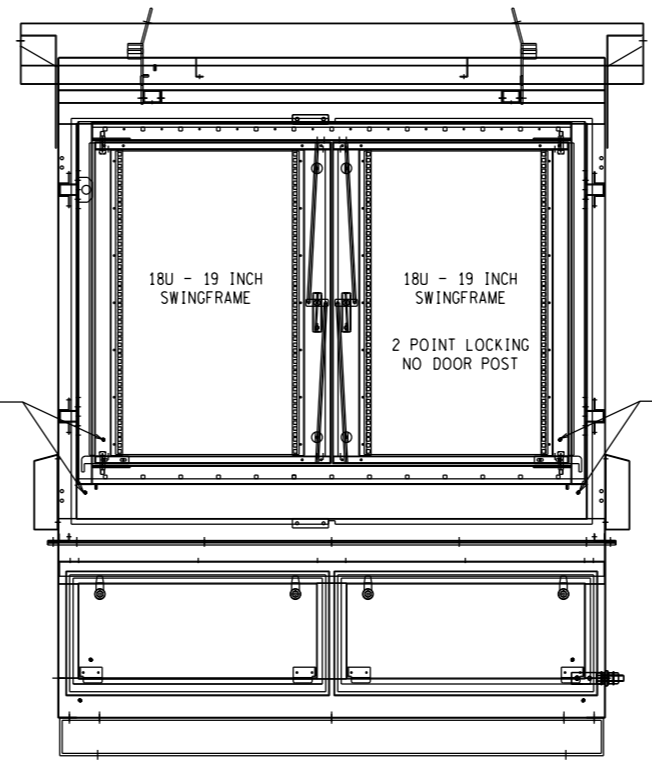

EARTH STUDS FOR
OUTER DOORS

EARTH STUD

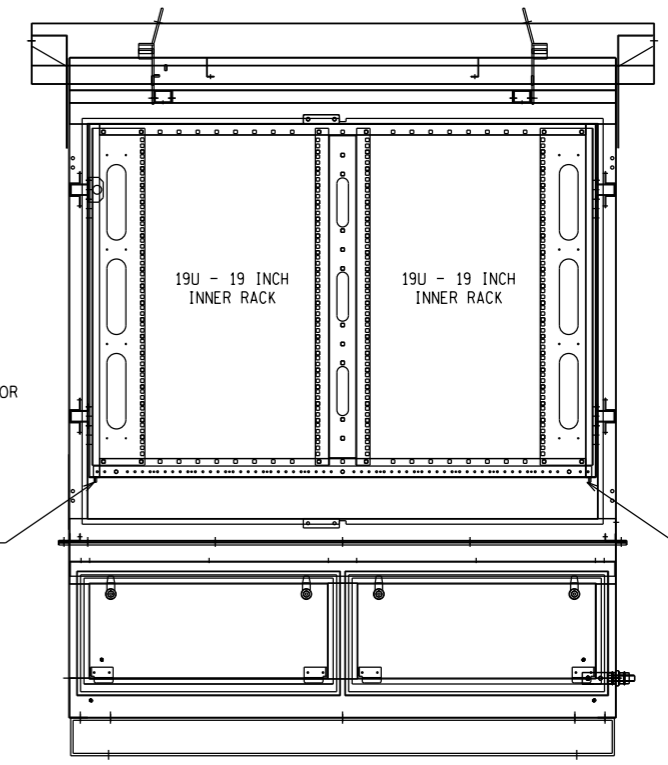

SECTIONAL TOP VIEW
(OPEN DOORS AND SWING FRAMES)

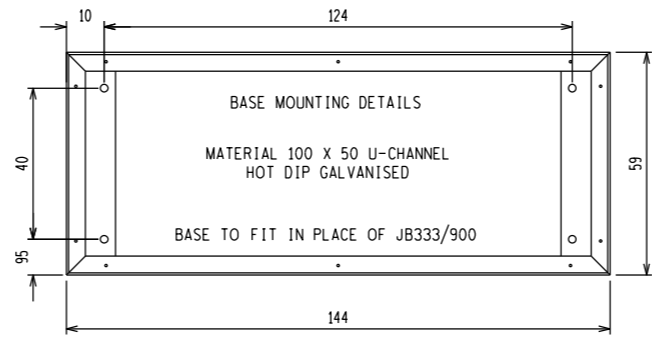

STUDS FOR
TERMINAL AND TRUNKING

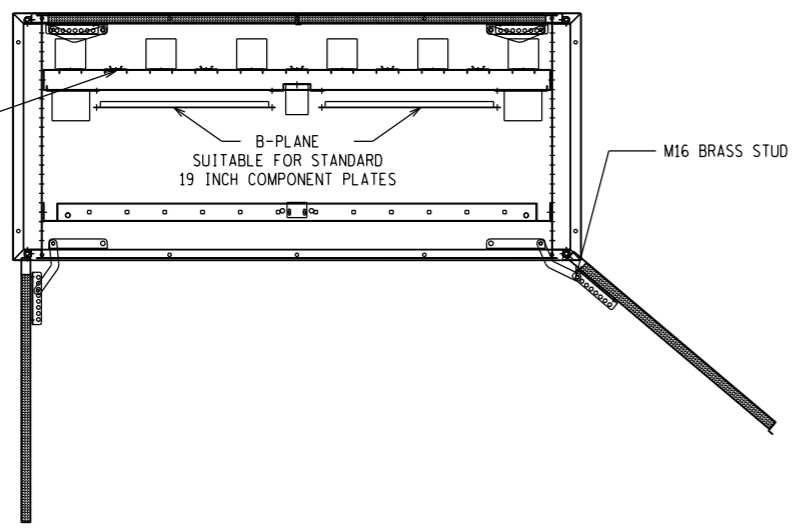

1. LEFT HAND SIDE DOORS TO FEATURE EXTERNAL BRACKETS FOR MOUNTING OF AN ENAMEL LABEL (APPROX 500 X 300MM).

REV	REVISION DESCRIPTION	BY	CHKD	APP	DATE
1	NEW SHEETS ADDED	M.W	V.KP		FEB 2021
	REVISION TO MASTER	BY	CHKD	APP	DATE

PROJECT APPROVED BY	DESIGN ACCEPTED BY		Eskom Holdings SOC Ltd Reg No 2002/015527/30
DATE	DATE		
PROJECT CHECKED BY	DESIGN APPROVED BY	GENERAL ARRANGEMENTS	
DATE	DATE		
PROJECT DRAWN BY	DESIGN CHECKED BY		
DATE	DATE	SCALE	DESIGN DRAWN BY
		1:10	M. MURALI
			DATE
			30/10/2017

SHEET NUMBER	REVISION
4	0

SHEET 4 OF 6 REVISION 0 MASTER FILED UNDER 0.52/30549

GLAND PLATES & MESH WIRE FOR AIRFLOW

BACK PLATE

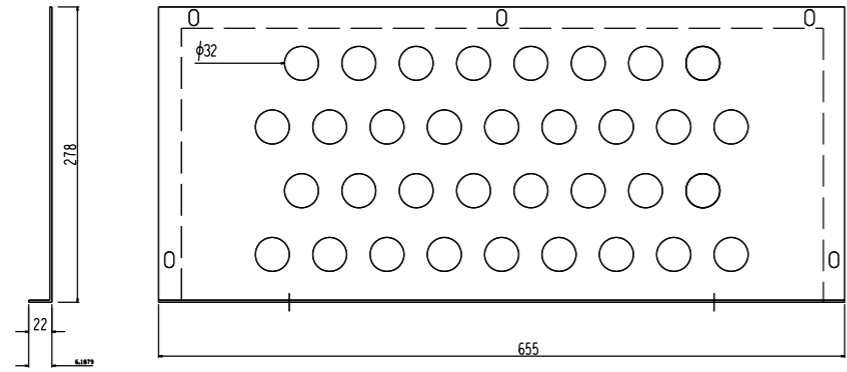

BACK PLATE COMMON

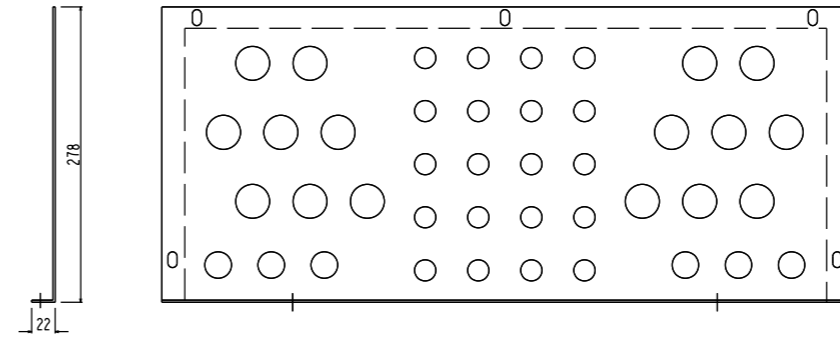

FRONT MESH PLATE

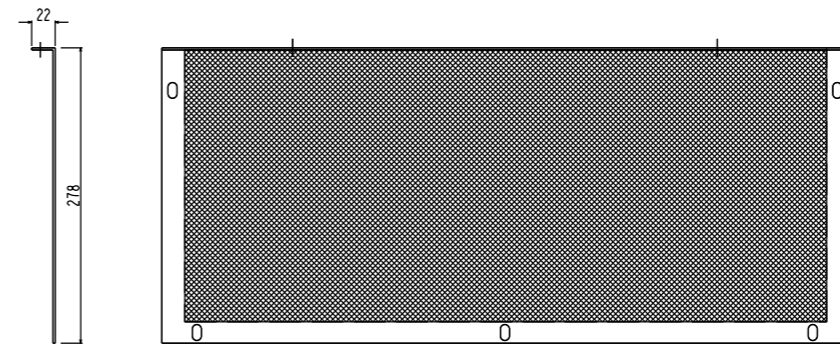

REV	DESCRIPTION	BY	CHKD	APP	DATE
1	NEW SHEETS ADDED	M.W	V.K.P		FEB 2021
	REVISION TO MASTER	BY	CHKD	APP	DATE

REV	REVISION DESCRIPTION	BY	CHKD	APP	DATE
	PROJECT APPROVED BY	DESIGN ACCEPTED BY		S. J. VAN ZYL	
	DATE	DATE		30/10/2017	
	PROJECT CHECKED BY	DESIGN APPROVED BY			
	DATE	DATE			
	PROJECT DRAWN BY	DESIGN CHECKED BY			
	DATE	DATE			
	SCALE	DESIGN DRAWN BY		M. MURALI	
		DATE		30/10/2017	
				SHEET NUMBER	REVISION
				6	0



Eskom Holdings SOC Ltd
Reg No 2002/015527/30

GLAND PLATES