

THE DESIGN OF THESE STRUCTURES IS GENERALLY IN ACCORDANCE WITH ASCE STANDARD 48-11, DESIGN OF STEEL TRANSMISSION POLE STRUCTURES. MANUFACTURE AND INSTALLATION SHOULD ALSO MEET THE REQUIREMENT OF THE SAME PUBLICATION

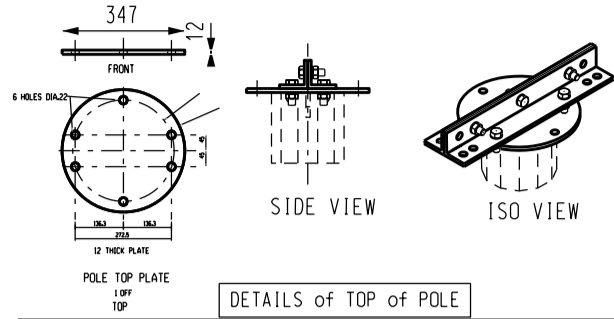

DETAILS of TOP of POLE

DESIGN WIND PRESSURE OF 1170pa WITH A 0.6 GUST FACTOR.

Structure Code:	Strsce0218kw.110
Phase Conductor:	Kingbird
Shield Conductor:	wolf
Wind Span: (m)	200
Weight Span: (m)	347
Vertical $\Phi - \Phi$ Spacing: (m)	2.40
Vertical $\epsilon - \Phi$ Spacing: (m)	2.20
CAH: (m)	11
Sides	12
Total Length: (m)	18
Tip diameter: (mm)	220
Base Diameter: (mm)	625
Wall Thickness: (mm)	8
Base Plate O.D.: (mm)	800
Base Plate I.D.: (mm)	520
Base Plate Thickness: (mm)	40
H.D Bolts: (Qty)	24
H.D Bolts Diameter: (mm)	24
H.D Bolts PCD: (mm)	715
Working Tip Load: (kN)	11
Base g.l Moment: (kNm)	190
Approximate mass: (tons)	1.70

POLES WILL HAVE THE LOWEST NUMBER OF SLIP JOINTS IN CONFORMANCE WITH THE LIMITATION IMPOSED BY THE LENGTH OF THE GALVANISING BATH. SLIP JOINT LENGTH IS TO BE 1.5 TIMES THE LARGEST I.D. OF THE SECTION.

FULL PENETRATION WELDS ARE TO BE USED ON: ALL SECTIONS JOINED BY THE CIRCUMFERENTIAL WELDS. ALL LONGITUDINAL WELDS WITHIN 75mm OF CIRCUMFERENTIAL WELDS OR IN THE FEMALE SECTION OF A SLIP JOINT.

ACCESS LADDER ARE REQUIRED ON ALL STRUCTURES FROM APPROXIMATELY 6m ABOVE GROUND LEVEL.

FOR INFORMATION ON STRUCTURE SECTION JACKING PLEASE REFER TO DSP_34-1683

NOTES:
MATERIAL :S355JR STEEL

WELDING TO BE 10mm CONTINUOUS SEAL TO SANS 10162

HOT DIP GALVANISING TO SANS 121. STRESS RELIEVING TO BE APPLIED IN ACCORDANCE WITH SANS 121

TOLERANCE:
ON DIMENSIONS 2mm

INCLINE VIEW

D-DT-7323/7324

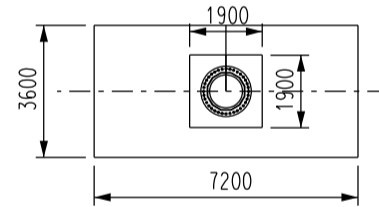
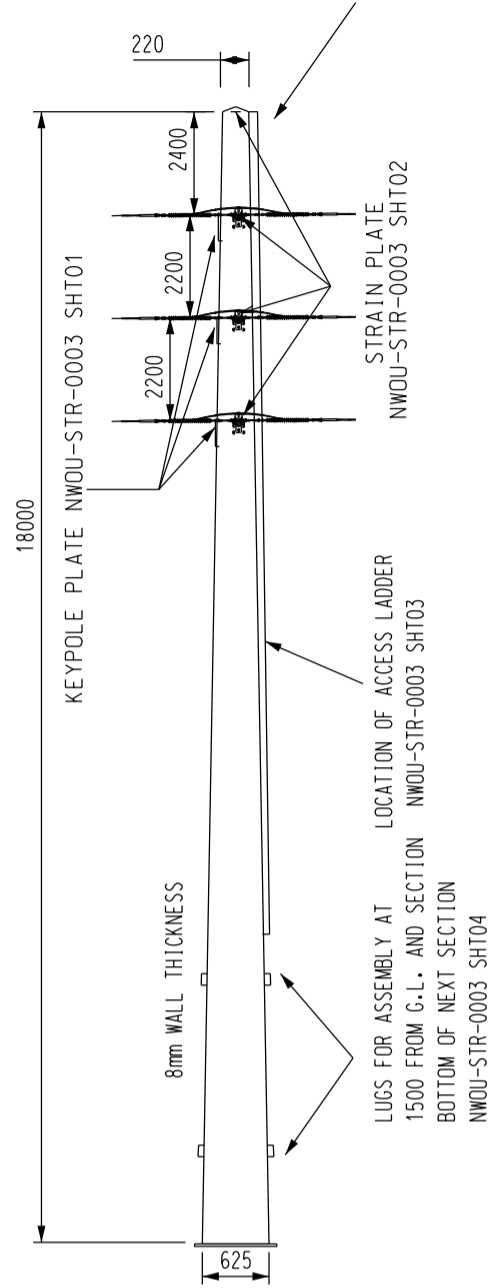

Ø	FIRST ISSUE	S.KGW	B.NYN	F.MAS	T.LANDELA	/ /	24/04/2020	
REV	REVISION DESCRIPTION	BY	CHKD SDO	CHKD PE	AUTH	DATE	PROJECT NO.	



132kV SINGLE CIRCUIT

(Ø - 2°) STEEL STRAIN
11m CAH

AUTH: T.LANDELA

DATE: 24/04/2020

CHKD PE: F.MASANGO

DATE: 24/04/2020

CHKD SDO: B.NYONI

DATE: 24/04/2020

DRAWN: S.KGWEDI

DATE: 17/04/2020

NWOU-STR-0005s1

SET

3

SHEET

1

REVISION

Ø