



a world class African city



**TITLE SPECIFICATION FOR
INTERGRATED SECURITY
SYSTEM**

REFERENCE CP_TSSTAN_237
PAGE: 1 OF 172
DATE: JUNE 2022

REV

1

TABLE OF CONTENTS

	Page
1. INTRODUCTION	5
2. SCOPE OF WORKS.....	5
3. NORMATIVE REFERENCES.....	5
3.1 STATUTORY REQUIREMENTS.....	6
4. DEFINITIONS AND ABBREVIATIONS	7
5. SECURITY & CONFIDENTIALITY	10
6. GENERAL REQUIREMENTS	10
7. NETWORKING EQUIPMENT	11
7.5.1 The patch panels shall be 19" rack mountable, 1U in height with 24 RJ45 outlets.	15
7.5.2 CAT 6 cable termination shall be LSA or 110 Insulation Displacement Connectors..	15
7.5.3 Front connectors to be RJ45 style IEC 60603-7-4/5.	15
7.5.4 Electrical performance to be Category 6.....	15
Panel Type :- 19" rack mountable with built on cable management.....	15
system	15
Height :- 24 ports 1U (44.5 mm)	15
Outlet style :- Unscreened 110 style IDC type	15
Color :- Black	15
Plating :- 50 micro inches of gold over 100 micro inches of nickel.....	15

IDC :- European LSA or 110 style Insulation Displacement Connectors (IDC).....	15
Wiring Pattern :- EIA/TIA/568B.....	15
Conformance :- Category 6 - ANSI/EIA/TIA 568B.2.1 : 2002 - ISO/IEC 11801 :2002	15
Certification :- (3P) Independent 3rd Party Certification.....	15
8. DATA CABLES	16
9. POWER SUPPLIES.....	21
9.1Mains Power Supply	21
9.2UPS SUPPLY	21
9.3POWER CABLE	23
10.ACCESS CONTROL SYSTEM	24
Maximum number of operations per day: 750	45
Duty cycle: 25%	45
Half day: 58	45
Full day: 37	45
11.CCTV	48
12.FIRE DETECTION	58
13.INTRUSION DETECTION SYSTEM	63
14.PUBLIC ADDRESS AND INTERCOM SYSTEMS.....	67
15.QUALITY MANAGEMENT	74
16.HEALTH AND SAFETY	74
17.ENVIRONMENTAL MANAGEMENT	74
ANNEXURE B – Revision information.....	76
18.ITEM NO 1 – CAT6 CABLE	77
19.ITEM NO 2 – CAT6 PATCH PANEL	79
20.ITEM NO 3 - OPTIC FIBER CABLE	81
21.ITEM NO 4 – UPS.....	84
22.ITEM NO 5 – DOOR READER CONTROLLER - POWER SUPPLY	87
23.ITEM NO 6 – DOOR MAGLOCK POWER SUPPLY	89
24.ITEM NO 7– SYSTEM INTERFACE CONTROLLER	91
25.ITEM NO 8 – DOOR READER CONTROLLER.....	94
26.- ITEM NO 9– CARD READER	96
27.ITEM NO 10 – EMERGENCY EXIT BREAK-GLASS	99
28.ITEM NO 11 – MAGLOCK	101
29.ITEM NO 12 – VISITOR MANAGEMENT SCANNER	103
30.ITEM NO 13 – GATE MOTOR	106
31.ITEM NO 14 – DEPOT MAIN GATE ENTRANCE TURNSTILE.....	108
32.ITEM NO 15 – DEPOT BUILDING MAIN ENTRANCE TURNSTILE	110
33.- ITEM NO 16 – VEHICLE BOOM.....	112
34.- ITEM NO 17 – PERIMETER CAMERAS	114

**SPECIFICATION FOR INTERGRATED
SECURITY SYSTEMS**

REFERENCE

REV

CP_TSSPEC_237

1

PAGE

3

172

35.ITEM NO 18 – DOOR CAMERAS	116
36.- ITEM NO 19 – VEHICLE LICENSE CAMERA	118
37.118	
38.ITEM NO 20 – DOME CAMERAS	120
39.ITEM NO 21 – DOME CAMERA LONG RANGE.....	122
40.- ITEM NO 22 – PTZ CAMERA	124
41.ITEM NO 23 – TEMP ALARM CAMERAS FOR CONDITION MONITORING	127
42.ITEM NO 24 – VIDEO RECORDERS.....	129
43.ITEM NO 25 – INFRARED ILLUMINATORS	132
44.ITEM NO 26 – FIRE ALARM CONTROL PANEL	134
45.ITEM NO 27 – FIRE DETECTION SENSORS	137
46.ITEM NO 28 – FIRE BEAM DETECTORS.....	140
47.ITEM NO 29 – DIGITAL INPUT CONTROL MODULES.....	143
48.ITEM NO 30 – ALARM KEYPAD.....	145
49.ITEM NO 31 – PIR.....	147
50.ITEM NO 32 – IR BEAMS	149
51.ITEM NO 33 – ETHERNET SWITCH	151
52.ITEM NO 34 – DIGITAL AUDIO EQUIPMNET	154
53.ITEM NO 35 – SECURED CALL STATIONS	157
54.ITEM NO 36 – INDOOR WALL MOUNTED SPEAKERS.....	159
55.- ITEM NO 37 – INDOOR CEILING MOUNTED SPEAKERS	161
56.- ITEM NO 38 – OUTDOOR HORN SPEAKERS.....	163
57.- ITEM NO 39 – IP INTERCOM STATION	165
58.ITEM NO 40 – VIDEO INTERCOM SYSTEM.....	168
TECHNICAL SCHEDULES A & B:	168
59.ITEM NO 41 – VIDEO WORKSTATION FOR CONDITION MONITORING.....	171

FOREWORD

This standard was prepared by the following work group members:

Recommendations for corrections, additions or deletions shall be addressed to the:

Research and Development General Manager

City Power Johannesburg (SOE) Ltd

P O Kiosk 38766

Booyens

2016

1. INTRODUCTION

City Power is a state owned entity and an electricity distributor for the City Of Johannesburg and surrounding areas. The entities' premises, which include depots, stations and substations, are National Key Points. This document lists requirements for a security system, which includes subsystems, equipment, software and peripherals that shall form part of the Integrated Security System (ISS). The ISS shall be implemented in line with the National Key Point Act.

2. SCOPE OF WORKS

City Power presently uses the LENEL On-Guard systems in their security installations and Ateis voice alarm system. The scope entails systems designs, supply and delivery, installation, and commissioning of the ISS, including integration with existing systems. All hardware, software and license shall form part of the scope. The ISS shall include without being limited to the following sub systems,

- 2.1 Access control systems
- 2.2 CCTV systems and Digital video management for CCTV installations
- 2.3 Fire Detection systems
- 2.4 Visitors management systems
- 2.5 Intrusion detection systems
- 2.6 PA systems
- 2.7 Video intercom systems
- 2.8 Backup power supplies for the above systems
- 2.9 All required civil work for the above systems

Integration of systems, equipment and services by different manufactures and service providers shall be subject to interoperability with City Power's existing systems. Contracting and sub-contracting shall be in line with City Power's policies and processes.

3. NORMATIVE REFERENCES

The following documents contain provisions that through reference in the text constitute requirements of this standard. At the time of publication, the editions indicated were valid. All standards and specifications are subject to revision and parties to agreements based on this specification are encouraged to investigate the possibility of applying the most recent editions of the documents listed below.

- | | |
|----------------------|---|
| SANS 369 Parts 1 & 2 | <i>Code of practice for the operation of fire protection measures</i>
<i>Part 1: Electrical actuation of gaseous total flooding extinguishing systems</i>
<i>Part 2: Mechanical actuation of gaseous total flooding and local application extinguishing systems</i> |
| SANS 10139 | <i>Fire detection and alarm systems for buildings - System design, installation and servicing</i> |
| SANS 530-9:2014 | <i>Fire detection and fire alarm systems for buildings: Code of practice for the design, installation, commissioning and maintenance of voice alarm systems.</i> |
| CE Marked | <i>CE marking is a mandatory conformity marking for certain products sold</i> |

	<i>within the European Economic Area (EEA) since 1985. The CE marking is also found on products sold outside the EEA that are manufactured in, or designed to be sold in the EEA.</i>
EMC 2004/108/EC SANS 50054	<i>Electromagnetic compatibility (EMC) - of electrical and electronic apparatus. Requirements and laboratory test for every component of fire detection and fire alarm system</i>
SANS 50054-11	<i>Fire detection and fire alarm systems. Manual call points</i>
SANS 50054-16	<i>Fire detection and fire alarm systems. Components for fire alarm voice alarm systems. Voice alarm control and indicating equipment</i>
SANS 50054-2	<i>Fire detection and fire alarm systems. Control and indicating equipment</i>
equipment SANS 50054-4	<i>Fire detection and fire alarm systems. Power supply equipment</i>
SANS 50054-5	<i>Fire detection and fire alarm systems. Heat detectors. Point detectors</i>
SANS 50054-7	<i>Fire detection and fire alarm systems. Smoke detectors. Point detectors using scattered light, transmitted light, transmitted light or ionization</i>
EN 60529	<i>Degrees of protection provided by enclosures (IP code)</i>
FIPS 201-1:	National Institute of Standards and Technologies Personal Identity Verification (PIV) of Federal Employees and Contractors
IEC 60332-1	Flame Propagation Test for a Single Insulated
Cable IEC 60332-3	Burning Behavior of Bunched Cables
IEC 60455-3-11	Specification for solvent less polymer sable resinous compounds used forelectrical insulation. Part 3: Specifications for individual materials. Sheet 11: Epoxy resin-based coating
powders IEC 60794-1-E4	Fiber optic Cable Testing Methods
IEEE 802.3af	refers to IEEE standard for Information Technology - IEEE 802.3af
ISO 15693	ISO standard for vicinity cards
ISO 7240-16	Fire detection and alarm systems - Sound system control and indicating Equipment
Machinery and Occupational Safety Act	Republic of South Africa - Machinery and Occupational Safety Act 85 of 1993 with special reference to Section 1 (Act & Regulations), Section 2 (Administrative Regulations), Section 6 (Electrical Installation Regulations.) and Section 16 (General Safety Regulations)
SANS 10142-1	The Wiring premises of low-voltage installations
SANS 1507	Electric Cables with Extruded Solid Dielectric Insulation for Fixed Installations (300/500V to 1900/3300V)
SANS 60332-3-24	Tests on electric and optical fiber cables under fire conditions Part 3-24: Tests for vertical flame spread of vertically mounted bundled wires or cables – Category B
1956UL 1076	Standard for Proprietary Burglar Alarm Units and Systems
UL 294	Standard for Access Control System Units
UL1076	Standard for Proprietary Burglar Alarm Units and Systems
ULC-S319-05	Electronic Access Control Systems
CP_TSSPEC_294	Specification for CCTV
CP_TSSTAN_065	Standard for repairs and maintenance of fire extinguishing equipment
CP_TSSTAN_059	Standard for an analogue addressable fire detection system
CP_TSSPEC_316	Specification for Security System

3.1 STATUTORY REQUIREMENTS

All material and equipment to be used for this installation shall be new and of an acceptable quality. The installation of electrical and electronic equipment shall always comply with the requirements, stipulations and regulations contained in the following Acts and shall be carried out in strict compliance with the following:-

3.1.1 FOR ELECTRONICS:

- 3.1.1.1 CE marked
- 3.1.1.2 FCC compliant: US Federal Communications Commission.
- 3.1.1.3 UL 294 standards for access control
- 3.1.1.4 ULC-S319-05 certification
- 3.1.1.5 ORD-C1076 proprietary codes as applicable
- 3.1.1.6 UL 1076 Security Listed
- 3.1.1.7 FIPS 201-1: National Institute of Standards and Technologies
- 3.1.1.8 PIV-I: Smart Card alliance: Personal Identity Verification
- 3.1.1.9 FASC-N Support: Open SSL

3.1.2 REGULATIONS AND ACTS:

- 3.1.2.1 Machinery and Occupational Safety Act 85 of 1993 with special reference to Section 1 (Act & Regulations), Section 2 (Administrative Regulations), Section 6 (Electrical Installation Regulations.) and Section 16 (General Safety Regulations).
- 3.1.2.2 The Mines and Works Act, No.27 of 1956 and subsequent amendments and regulations issuedthere under.
- 3.1.2.3 The Electricity Act, No.40 of 1958.
- 3.1.2.4 Code of Practice for the Wiring of Premises - SANS 10142-1: Part 1: low Voltage Installations (latest edition)
- 3.1.2.5 The Contractor shall, on completion of all power electrical Works and installation work, issue aCertificate of Compliance as given in SANS 10142-1, Part 1, Low voltage Installations(latest edition).
- 3.1.2.6 National Key Point Act 102 of 1980 The Electricity ActRepublic of South Africa - The Electricity Act, No. 40 of 1958

4. DEFINITIONS AND ABBREVIATIONS

The definitions and abbreviations in listed below shall apply to this specification.

Table 1: List of abbreviations and definitions

μm / micron	micrometer
1000Base -SX	100BASE-LX is specified to work over a distance of up to 5 km over 10 μm single-mode fiber
1000Base-T	1000BASE-T (also known as IEEE 802.3ab) is a standard for Gigabit Ethernetover copper wiring. Each 1000BASE-T network segment can be a maximum length of 100 meters, and shall use Category 5 cable or better.

10GBASE-T	10GBASE-T, or IEEE 802.3an-2006, is a standard released in 2006 to provide 10 Gbit/s connections over unshielded or shielded twisted pair cables, over distances up to 100 meters. Category 6a is required to reach the full distance of 100 meters
AC	Alternating Current
AES / EBU	(AES - Audio Engineering Society / European Broadcasting Union) - A professional interface for transferring digital audio.
B/W	Black and White
CAT6	Standardized cable for Gigabit Ethernet and other network physical layers. Category 6 is defined at frequencies up to 500 MHz
CCTV	Closed Circuit Television is a TV system in which signals are not publicly distributed but are monitored, primarily for surveillance and security purposes. CCTV relies on strategic placement of cameras, and observation of the camera's input on monitors somewhere.
CNC machinery	A process used in the manufacturing sector that involves the use of computers to control machine tools. Tools that can be controlled in this manner includes lathes, mills, routers and grinders. The CNC stands for Computer Numerical Control.
dB	The decibel (dB) is a logarithmic unit used to express the ratio of two values of a physical quantity, often power or intensity.
DC	Direct Current
DIN Rail	Metal rail of a standard type widely used for mounting circuit breakers and industrial control equipment inside equipment racks. These products are typically made from cold rolled carbon steel sheet with zinc-plated and chromate bright surface finish.
DIP Switches	An arrangement of switches in a dual in-line package used to select the operating mode of a device such as a printer.
f-"number" (e.g. f1.4, f2.8, f5.6...)	Optics: The F- "number" (focal ratio/F-stop) is the ratio of the lens focal length to the diameter of the entrance pupil of a lens.
FASC-N Support: Open SSL	Federal Agency Smart Credential Number
FCC	Federal Communications Commission
FNF	Flexible Net Flow
Form-C 5A	5 Ampere, single pole double throw (Form C) relay
Gigabit	In data communications, a gigabit is one billion bits, or 1000000000 bits. It's commonly used for measuring the amount of data that is transferred in a second between two telecommunication points.
H.264	H.264 or MPEG-4 Part 10, Advanced Video Coding (MPEG-4 AVC) is a block-oriented motion-compensation-based video compression standard.
HDTV	Digital TV broadcasting format where the broadcast transmits widescreen pictures with more detail and quality than found in a standard analogue television, or other digital television formats.
HID	Human Interface Device
Hz	Hertz
IDRC	Intelligent Dual Reader Controller

IP Rating	IP (or 'Ingress Protection") They are used to define levels of sealing effectiveness of electrical enclosures against intrusion from foreign bodies and moisture.
IPv4	Internet Protocol version 4
IPv6	Internet Protocol version 6
IR	Infra-red
IRB	Infra-Red Beam – motion detection
IRE	Institute of Radio Engineers - Unit used for measurement of composite video signals
SIC	System Interface Controllers
ISS	Integrated Security System
IT Network	A system of computers that are joined together so that they can communicate by exchanging information and sharing resources.
kA	kilo Ampere
km	kilometer
kV	Kilovolt
LCD	Liquid crystal display
LED	Light-emitting diode
LSZH	Low smoke zero halogen or low smoke free of halogen is a material classification typically used for cable jacketing in the wire and cable industry.
mA	mill Ampere
Mbps	Megabits Per Second
MHz	Mega Hertz
mK	milli Kelvin
MOD AASHTO	Compaction of subgrades is usually controlled by a density and method
MOD BUS	Serial Communications Protocol
MOV	Maximum Over Voltage
MV Switchgear	In an electric power system, switchgear is the combination of electrical disconnect switches, fuses or circuit breakers used to control, protect and isolate electrical equipment. Usually rated at 6.6kV or 11kV
N/C	Normally Closed
N/O	Normally Open
NETD	Noise Equivalent Temperature Difference
NFC	Near Field Communication
nm	Nanometer
NVR	Network Video Recorder
∅	Phi - usually refers to Diameter
OFC	Optic Fiber Cable - refers to the medium and the technology associated with the transmission of information as light impulses along a glass or plastic wire or fiber.
Open SSL	SSL - Secure Socket Layer. OpenSSL - Open Source Software library implementation of SSL protocol.
ORHVS	Operating Regulations for High Voltage Systems
OSDP	Open Supervised Device Protocol

OTDR	Optical Time - Domain Reflectometer
PVC	Polyvinyl Chloride is a synthetic plastic polymer.
PA	Public Address
PC Board	A printed circuit board (PCB) mechanically supports and electrically connects electronic components using conductive tracks, pads and other features etched from copper sheets laminated onto a non-conductive substrate.
PIN	Personal Identification Number
PIR	Passive Infrared sensor - motion detector
PIV-I	Personal Identity Verification Interoperability
P-Iris	Camera solutions for "precise" iris that uses both the ability to automatically adjust (auto iris) with controls in the camera's software to create improved video clarity and depth of field
POE	Power over Ethernet
PTZ	Pan Tilt Zoom
Qos	Quality of Service
REX Buttons	Request for Exit button
SANS	South African National Standards
SCADA	Supervisory control and data acquisition is a system that operates with coded signals over communication channels so as to provide control of remote equipment (using typically one communication channel per remote station).
SFP	Small form-factor pluggable
SMT	Surface-mount technology
ST-ST	Fiber Optic connector with straight tip (ST) connectors
TCP/IP	Transmission Control Protocol / Internet Protocol
UPS	Uninterruptable Power Supply
V	Volt
VLAN	A virtual LAN is any broadcast domain that is partitioned and isolated in a computer network at the data link layer.. LAN is an abbreviation of local areanetwork.
W	Watt

5. SECURITY & CONFIDENTIALITY

The information in this specification and all other specifications, drawings and schedules issue together with this specification are confidential. The specifications shall not be copied or used without the written consent. This document and the information contained is copyright. It shall not, without prior written consent of City Power be reproduced by any process or communicated to any party or used in any way other than for the purpose for which it was issued. Infringers shall incur liability for damages.

The successful Contractor shall further be required to sign a Confidentiality Agreement with City Power before the Contract is handed down to the Contractor.

6. GENERAL REQUIREMENTS

- 6.1 City Power requires new security equipment which is fully compatible with the existing security management platform located at Reuven.
- 6.2 The security system shall provide a number of functions including the ability to regulate access

to various sites through specific doors and gates to secured access of sites and facilities of City Power.

- 6.3 The system on a site shall utilize a single seamlessly integrated database for all functionality.
- 6.4 One of the security systems primary purposes shall be to provide access control. The system shall be able to grant or deny access to various areas, shall define access levels, and set time zones and holidays for access control an input/output linkage feature shall allow linking of monitorzone points to output control points within Intelligent System Controllers (ISC's). The system shall further support any Wiegand card format for use at access control card readers. All new SIC's or door controllers installed on sites shall be natively compatible and be able to integrate with the main Access Control system currently being used by City Power's
- 6.5 City Power thus requires a high-performance real time (24/7) Digital Surveillance Solution on each site where a CCTV system is installed. It shall be fully compatible with the existing City Power Video Management platform, currently installed at City Power.
- 6.6 The CCTV system shall be able to stream, record and store recorded as and when they occur.
- 6.7 This integration shall be provided with one operating environment. The operating environment shall be fully multi-tasking multi-threading a Microsoft Windows 7/10 Operating System.
- 6.8 The system shall be written such that all system modules (access control, alarm monitoring, credential management, digital video, visitor management, intrusion detection, asset management, etc.) are developed and built from a unified 64-bit source code set.
- 6.9 There shall not be separate source code basis for the individual modules of the system on a site.
- 6.10 The security operating and data logging systems shall be able to communicate with the main control center equipment and transmit data via City Power's IP based fiber optic cable network.
- 6.11 Switches shall be placed and used at various sites to terminate and link all systems and City Power's ICT and telecommunication department shall facilitate that as to CP_TSSPEC_263
- 6.12 City Power shall be responsible for the programming of the main control center.
-
- 6.13 All wiring and cables linking field mounted devices with the control room equipment, as well as between individual devices placed in a local group such as at card readers, DRI's, power supplies, door monitors, REX buttons, etc., shall be installed in 20 mm or 25mm Ø electro galvanized conduit and draw boxes.
- 6.14 Conduit runs shall be supported on galvanized spacer saddles at distances not exceeding 1,5m. Tails of equipment to the nearest connection box shall be protected with flexible steel tubing. No open wiring or cables shall be permitted anywhere on a site.
- 6.15 The ISS shall be capable of 3rd parties remote access to enable 3rd parties monitoring and armed response.

7. NETWORKING EQUIPMENT

7.1 General requirements

- 7.1.1 Various cable types are required for the networking of the Integrated Security System in line with CP_TSSPEC_263.
- 7.1.2 Mylar shielded cable and Ethernet cable shall be used mainly inside building and substations.

-
- 7.1.3 Fiber optic cables shall be used to form links between buildings, between substations and between a substation building and outdoor cameras.
- 7.1.4 Media converters shall be used to convert from one medium to the other.
- 7.1.5 All cable indoors and outdoors, installed between cabinets containing equipment or between equipment shall be installed in electro-galvanized conduit or in flexible stainless steel tubing.
- 7.1.6 Termination links in flexible tubing from the nearest draw box to equipment shall meet City Power's standard.
- 7.1.7 Conduit systems for wiring installation shall consist of electro-galvanized conduit and drawboxes of 20mm or 25mmØ and conduit shall be mounted on surface of brick or concrete.
- 7.1.8 Saddles shall be fixed to concrete or brick with small expanding bolts
- 7.1.9 Galvanized spacer saddles installed at distances of not more than 1,5m apart. The spacing of saddles shall be planned properly on site and the end-of-conduit-run saddles shall be installed towards the end of the conduit or near any off-set of the conduit at draw box conduit entries.
- 7.1.10 Conduit systems shall have been completed from end to end before cable is draw in and conduits and the draw boxes shall be cleaned before wiring or cabling is installed.
- 7.1.11 The service provider shall submit all fiber and CAT6 testing documentation and as-built drawings during handover / commissioning process as well as the cabling manufacturer warranty issued for the site, upon completion.
- 7.1.12 All CAT6 cabling shall be terminated using RJ45 connectors and shall comply with City Power's standards.
- 7.1.13 End splices of fiber optic cable shall be complete with pigtails and fiber optic pigtail plugs.
- 7.1.14 Mylar shielded cable and Ethernet cable shall be installed in separate conduit, which shall also be separate from power cable.
-
- 7.1.15 Mylar shielded instrumentation cable in this contract shall be utilized for equipment such as door controllers, card readers, card reader system controls and other networking purposes.
- 7.1.16 CAT 6 Ethernet cable in this contract shall be for connection of cameras to Ethernet switches (POE) internal rack connections of digital recording equipment to switches and system control cards to Ethernet switches.
- 7.1.17 Ethernet cable shall also be for connections to outdoor pole mounted cameras via media converters.
- 7.1.18 OFC in this contract shall comply with the requirements listed below and shall form link between buildings on a site and between building on a site to field equipment such as cameras in outdoor substations.
- 7.1.19 OFC shall be terminated in housings, patch panels and cubicles using appropriate termination equipment, plugs and pigtails. OFC outside buildings shall be installed in underground sleeves.
- 7.1.20 Single runs of OFC shall be mounted in a conduit and draw box system on surface in building structures. Galvanized metal trucking shall be used where more than one OFC is installed on the same main OFC route.

-
- 7.1.21 Should a need arise, OFC shall be laid with power cable in the same conduit, underground sleeve or trucking route.
 - 7.1.22 Fiber optic cable splice boxes shall be of the 24 port ST panel type
 - 7.1.23 Cables shall not be mounted open internally to a building or externally to a building.
 - 7.1.24 No conduit or trucking shall be installed externally on buildings.
 - 7.1.25 Conduit and draw box systems shall be terminated at both ends of a run in the cabinet, panel or housing.
 - 7.1.26 It shall not be permissible that that cable is exposed, even for a short distance. The last section of cable from a draw box to any device shall be housing in metal spiral tubing where conduit cannot be terminated in the device itself (i.e. cameras and PIR's.)
 - 7.1.27 The cost for draw-boxes shall be covered in the Contractors priced unit rates for conduit.
 - 7.1.28 Instrumentation cable ends in cabinets or housings shall be kept as short as possible.

7.2 Racks for Equipment

- 7.2.1 Racks (cabinets) in this Contract shall be of the 19", 42u x 600 x 1000mm deep type complete with 4-way, 10-way rack mounted PDU, bottom gland plate and perforated doors.
- 7.2.2 Floor standing cabinets shall be with of either glass or steel door. The type of door to be shall suite the conditions on site.
- 7.2.3 Substation rooms and depots shall be equipped with steel door cabinets with dust proof door seals.
- 7.2.4 12U Swing frame, wall mounted cabinets shall be used in locations requiring remote cabinets. These shall be linked to the main data cabinet with CAT 6 cable or OFC.
- 7.2.5 Cabinets shall be of the totally enclosed type (no open sides) and manufactured to the international standards on CNC machinery before being powder coated to a thickness of 70Microns.
- 7.2.6 Cabinets shall consist of components which can be assembled on site. Components shall be in the form of separate side panel, rear panel, top panel, bottom panel and doors. Doors shall be fitted with lockable swing out handles.
- 7.2.7 Steelwork shall be 1,2mm mild steel and powder coated. Steelwork shall be properly phosphated before powder coating. Side and back rails shall be of the same type and finish as the casing of the cabinet.
- 7.2.8 The cabinet shall rack mount rails shall be 450,85 mm apart and shall be the full height of the cabinet. These shall be installed both in the front and back of the cabinets. A 42U rack shall have an internal rack unit height dimension of 1866 mm.
- 7.2.9 Cabinet design shall allow for easy access for adjustments (front, back and sides), space saving door utilization, conveniently placed cable ducts and easy cable entry and exit points of the cabinet allowing for a smooth and friendly installation experience.
- 7.2.10 The rack shall a 10 way rack mounted PDU power distribution to supply 230VAC to network equipment and switches. The PDU in the stack shall be shared as a common resource among all the switches.
- 7.2.11 The video recording equipment, Ethernet switches and system controllers and the applicable power supplies, together with all apparatus for such equipment shall be mounted

in racks.

7.2.12 The positions of racks are shown on the layout drawings accompanying this specification.

7.3 ETHERNET SWITCHES

7.3.1 Ethernet switches shall be of the 24 SFP port, 10/100Mbps, and be suitable for Power Over Ethernet (POE+) use.

7.3.2 The switch shall be full IEEE 802.3at (POE+) networking protocol compliant and shall support IPv4 and IPv6 routing.

7.3.3 The switch shall be suitable for a single universal IOS image across all license levels for an easy upgrade path for software licenses.

7.3.4 Software support for IPv4 and IPv6 routing, multicast routing, modular quality of service (QoS), Flexible Net Flow (FNF), and enhanced security features shall be included.

7.3.5 Fiber modules shall be specified further herein.

7.3.6 The necessary stacking kit shall be supplied with each switch. The stacking cables shall have a bandwidth of 480Gbps.

7.3.7 Racks are specified in clause "14 Metal Enclosures" hereof.

Copper Ports:	24 10/100 Mbps data PoE+
Power:	Dual redundant, modular and three modular fans providing redundancy
PoE:	Full IEEE 802.3at (PoE+) with 30W power on all copper ports in 1 rack unit
Protocol:	Software support for IPv4 and IPv6 routing, multicast routing, modular quality of service (QoS) Single universal IOS Software image across all license levels, providing an easy upgrade path for software features
Warranty:	Enhanced limited lifetime warranty (E-LLW) with next business day (NBD) advance hardware replacement and 90-day access to Technical Assistance Centre (TAC) support
Network Modules:	4 x Gigabit Ethernet with Small Form-Factor Pluggable (SFP) receptacles
Environment:	
Temperature:	Operating: -40 - 75°C Storage: -40 - 75°C
Humidity:	Operating: 5 - 95% (Non-condensing) Storage: 5 - 95% (Non-condensing)
Locally Supported:	Yes

7.3.8 Fiber optic network modules are required in this contract for fiber optic cable connections to the Ethernet switches specified earlier herein.

7.3.9 The module shall have a dual color LED indicator beneath each slot which shall give the following indications:

- 7.3.9.1 Off - Link is off
- 7.3.9.2 Green - Link is on, no activity
- 7.3.9.3 Blink Green-Activity on link, no faults
- 7.3.9.4 Blink Amber-Link is off due to a fault or because it has exceeded a

7.3.9.5 Amber - limit set in the switch software
Link to the SFP is disabled

7.3.10 Link faults shall occur when non-compliant cabling is connected to an SFP port.

7.3.11 The module shall fit network switch and shall lock in when fully inserted.

7.3.12 Proper wrist earth straps shall be used by the Contractor when installing or removing equipment from the rack.

7.4 Fiber to Copper Converters

7.4.1 The fiber to copper converters for this Contract shall be of the 1000Mbps, Gigabit, Single-mode type media converter LC type.

7.4.2 The converter shall transparently convert to/from 1000Base-T Ethernet signals and 1000Base-LX optical signals to extend an Ethernet connection over a Single-mode Fiber backbone.

7.4.3 The converters shall be used on both side of the Single- mode fiber cables, at the Ethernet switch between Depot or site buildings, between substation indoor and outdoor Ethernet switches, placed in cabinets and at the poles for PTZ camera signal routing back to the video recorder in the 42U Data Cabinet.

7.5 PATCH PANEL

7.5.1 The patch panels shall be 19" rack mountable, 1U in height with 24 RJ45 outlets.

7.5.2 CAT 6 cable termination shall be LSA or 110 Insulation Displacement Connectors.

7.5.3 Front connectors to be RJ45 style IEC 60603-7-4/5.

7.5.4 Electrical performance to be Category 6.

Panel Type:-19" rack mountable with built on cable management system

Height:-24 ports 1U (44.5 mm)

Outlet style:-Unscreened 110 style IDC type

Color:-Black

Plating:-50 micro inches of gold over 100 micro inches of nickel

IDC:-European LSA or 110 style Insulation Displacement Connectors (IDC)

Wiring Pattern:-EIA/TIA/568B

Conformance:-Category 6 - ANSI/EIA/TIA 568B.2.1 : 2002 - ISO/IEC 11801 :2002

Certification:- (3P) Independent 3rd Party Certification

7.6 METAL ENCLOSURES

7.6.1 Sheet metal cabinets and enclosures for indoor use in this contract shall be as dust proof as possible and shall have a neoprene seal on the inside of the door for dust proofing. Indoor cabinets shall manufactured from at least 1,6mm sheet steel and shall be phosphate and epoxy power coated in compliance with IEC 60455-3-11:1988. These cabinets shall be pre-prepared to accept PC boards mounted on clip-in stand-off posts.

7.6.2 Wall mounted enclosures for power supplies and for the housing of electronic equipment shall have key locks and shall be supplied with 2 keys for each lock.

7.6.3 Racks mounted cabinets in control rooms shall be of the 19" type, manufactured from at

least 1,6 mm sheet steel and shall be phosphate and epoxy powder coated in compliance with IEC 60455-3-11:1988. These cabinets shall be complete with shatterproof glass doors or ventilated steel doors. Ventilation openings shall be rat proof and shall have replaceable dust filters. Rack shall be suitable to add ventilation fan trays at the top of the cabinet. Racks shall further have slotted or threaded insert positions on vertical rails on the sides, in the front of the rack and in the rear of the rack for the mounting of equipment and for the mounting of trays, DIN rails and blank covers.

- 7.6.4 Racks for video recorder, POE switches and fiber interface modules shall be of the 42U, shall be 600mm x 1000mm deep, and shall be suitable to be mounted on casters or wall fixing. Extended racks for CCTV drives shall not be smaller than 3U size
- 7.6.5 Cabinets shall have stainless steel hinges, locks and swing handles and shall ensure that doors and covers can be closed securely.
- 7.6.6 Cabinets and sheet metal housing shall be completely rat proof when the doors or covers are closed.
- 7.6.7 Punch-outs or other openings for cables not in use shall not be left open but shall be sealed with knock-in plastic caps or powder coated steel plates.
- 7.6.8 All draw boxes or patch panels shall have lids or doors which shall be screwed down or held in the closed position with lockable handles or turn locks and keys.
- 7.6.9 Draw boxes or cabinets mounted in buildings which are accessible to personnel or visitors shall be mounted at a height of not less than 2,2 m from floor level to prevent tampering with the equipment.

8. DATA CABLES

8.1 General Requirements

- 8.1.1 Mylar shielded instrumentation cable in this contract shall be utilized for equipment such as door controllers, card readers and card reader system controls and other networking purposes. Mylar cable shall be mounted in a conduit and draw box system on surface in buildings and structures. More than one Mylar cable shall be installed in one conduit, especially in short sections of conduit on condition that conduit capacity is not exceeded.
- 8.1.2 Ethernet cable in this contract shall be certified CAT 6 UTP cable. It shall be used for connection of cameras to Ethernet switches, internal rack connections of digital recording equipment to switches and system control cards to Ethernet switches. Ethernet cable shall also be used on both ends of fiber optic cable via media converters for connections to outdoor pole mounted cameras. Single runs of Ethernet cable shall be mounted in a conduit and draw box system on surface in building structures.
- 8.1.3 Optic Fiber Cable (OFC) in this contract shall be used for installation between buildings on one site and between buildings on a site to field equipment such as cameras in outdoor substations. The cable installation shall be complete after installation and shall be fitted with the necessary mid-couplers, fly-leads and connectors. Every OFC route shall be OTDR tested after completion and the test results shall be recorded on test sheets for inclusion in the operational manuals.
- 8.1.4 OFC shall be terminated in housings, patch panels and cubicles using appropriate termination equipment, plugs and pigtails. OFC outside buildings shall be installed in underground sleeves. Single runs of OFC shall be mounted in a conduit and draw box system on surface in building structures. Galvanized metal trunking shall be used where

more than one OFC is installed on the same main OFC route.

- 8.1.5 OFC shall be installed together with power or other instrumentation cable in the same conduit, underground sleeve or trunking route.
- 8.1.6 Cables shall not be mounted outside or without the conduit neither indoors or outdoors.
- 8.1.7 The last section of cable from a draw box to any device shall be housing in metal spiral tubing where conduit cannot be terminated in the device itself i.e. cameras and PIR's.
- 8.1.8 Instrumentation cable ends in cabinets or housings shall be kept as short as possible.
- 8.1.9 The use of second hand cable and second hand stranded P.V.C. insulated conductors shall not be permitted.
- 8.1.10 Underground cable shall only be laid in sleeves of proper dimensions. Underground sleeves shall be provided with manholes or draw holes at all bends and at 100m maximum distances apart. 10mm Nylon rope shall be threaded through all underground sleeves when sleeves are installed
- 8.1.11 Excavations for cable sleeves shall be at least 600mm deep. Sleeves installed shall be in accordance with CP_TSSPEC_134 – such sleeves shall have a Class 6 rating to prevent collapsing during backfill and compaction of trenches.
- 8.1.12 The contractor shall use galvanized steel trunking with clip-in covers on surface of buildings with the permission of the Engineer.
- 8.1.13 The Contractor shall provide wiring and cable installed in a neat and competent manner and installed parallel with or at right angles to the sides and back of any box, enclosure or cabinet. All conductors terminated, spliced, or otherwise interrupted in any enclosure, cabinet, mounting or junction box shall be connected to terminal blocks.
- 8.1.14 All new cabling shall be continuous from component to component. Intermittent splices shall not be permitted in any case.
- 8.1.15 Mark each terminal in accordance with the wiring diagrams of the system. Make all connections with approved pressure type terminal blocks, which are securely mounted. No soldering shall be accepted, where terminal boxes cannot be fitted approval shall be requested to use crimps.
- 8.1.16 Wiring and cable ends for low voltage-, control-, interlocking-, alarm-, measuring- and D.C. circuits shall terminate on numbered wiring terminals or dedicated plugs and sockets.
- 8.1.17 The correct terminal size as recommended by the manufacturer for each conductor to be connected shall be used throughout. The terminal numbers shall appear on the wiring diagrams of the enclosure.
- 8.1.18 Terminals for power wiring shall be separated for different voltages.
- 8.1.19 All single core conductors terminating at terminals shall be fitted with lugs. The lugs shall be crimped to the end of the conductor. The correct amount of insulation shall be stripped from the end to fit into the terminal. Strands shall not be cut from the end of the conductor.
- 8.1.20 The use of wire nuts or similar devices shall not be allowed.
- 8.1.21 Grommets shall be installed in each hole in the metalwork through which conductor's pass in a cabinet or enclosure. Grommets shall further also be used in all conduit openings to prevent damage to the wire insulation during installation (pulling of cables).
- 8.1.22 Conductors attached to hinged panels and doors shall be secured on both the door and

the frame and shall be looped between the two points. The loop shall be arranged to produce a twisting motion when the door is opened or closed. A flexible protection sleeve shall be installed over the conductors

- 8.1.23 Labelling of any circuit at terminal blocks in junction boxes, enclosures and cabinets shall be provided at each conductor connection. Each conductor or cable shall have a shrink-wrap or similar label to provide a unique and specific designation.
- 8.1.24 Indelible printed type labels on slide in PVC keepers shall be used for labelling of single core wiring ends. It shall not be possible to remove the keeper from the wire with the removal of the lug on the end of the wire.
- 8.1.25 Under no circumstances shall PVC adhesive tape be used for the bunching of conductors or for the color identification of conductors.
- 8.1.26 Each terminal location or cabinet shall contain a laminated drawing which indicates each conductor, its label, circuit, and terminal number. The laminated drawing shall be neat, using 12 point lettering minimum size, and mounted within each cabinet, panel, or unit so that it does not interfere with the wiring or terminals.
- 8.1.27 The control termination boxes, enclosures, and cabinets shall be installed at locations suitable for efficient future service and as approved by the Client's representative. The termination enclosure shall be surface mounted with the top no more than 2m above finished floor level.
- 8.1.28 Service boxes required to be installed in unsecured areas (hallways, at security doors, in passages, etc.) shall be installed in a concealed area, whenever possible, such as in an adjoining office, or at a height which reduces the possibility for tampering.
- 8.1.29 The exact wire-way locations on site shall be approved by the Engineer or relevant City Power committee prior to construction. Cable routing shall be in accordance with site layout drawings.

8.2 Trunking

~~8.2.1 A conduit route shall be completely mounted before cables or wiring are installed.~~

- 8.2.2 Spare conduit runs shall have galvanized draw wire installed.
- 8.2.3 All conduit and cable routes shall be marked up on "as built" drawings.
- 8.2.4 Separate conduit runs or steel wiring trunking and draw boxes shall be used for:
 - a 230V wiring or cables
 - b 12 – 24VDC power wiring
 - c Data cables such as Mylar cable or Ethernet cable
- 8.2.5 Fiber optic cable shall be installed together with power cables in conduit and trunking in buildings or underground sleeves.
- 8.2.6 Parallel conduit runs on walls in buildings shall be installed neatly next to one another and crossing of conduit runs shall be avoided.
- 8.2.7 No conduit or trunking shall be installed externally on buildings.
- 8.2.8 Conduit and draw box systems shall be terminated at both ends of a run in the cabinet, panel or housing. Conduit shall not be stopped short of such a termination so that cable is not exposed, even for a short distance.

8.3 Mylar Cable

Mylar cable shall in general be of the 2 pair or 4 pair type. Mylar cable used for RS-485 communication in networks shall be of the low capacitance, 120Ω impedance type and shall consist of 2 twisted pairs and shall have an additional tinned copper woven braided screen over the outer Mylar screen.

- 8.3.1 The cable pairs shall have a fast twist and shall Mylar cable comply with the following requirements:
 - 8.3.1.1 0,22mm² (7/0,22mm) tinned copper conductors (except for magnetic lock supplies. See note below)
 - 8.3.1.2 PVC insulated, Fast twisted pairs, color coded.
 - 8.3.1.3 Fire safety rating-IEC 60332-1
 - 8.3.1.4 Tinned copper drain wire for each pair
 - 8.3.1.5 Individual aluminum-Mylar foil screen over each pair
 - 8.3.1.6 Tinned copper drain wire for overall screen.
 - 8.3.1.7 Overall aluminum –Mylar foil screen and tinned copper braid screen
 - 8.3.1.8 PVC overall sheath (standard color – grey) - zero halogen (LSZH)
 - 8.3.1.9 1 mm² cable shall be used for connection of magnetic locks from the power supply of these devices
- 8.3.2 The cable shall further be of 440V grade.
- 8.3.3 The tinned drain wire of Mylar cable shall only be grounded to an approved earth point at only one end of the cable or as recommended by the associated equipment manufacturer.

8.4 CAT 6 CABLE

- 8.4.1 The cable shall be a high performance 4 pair Category 6, 23 AWG Unshielded Twisted Pair (UTP) with solid copper conductors, polyolefin insulated PVC or low-flammability sheath and color-coded pairs.
- 8.4.2 The pairs shall be around an "X" shaped filler, for NEXT (near-end Cross talk) performance.
- 8.4.3 The cable shall meet EN 50288-5/6.
- 8.4.4 The cable shall have current independent third party approval status.

Nominal Overall Diameter	:- Between 6.20 and 7.00 mm
Weight	:- Between 43.10 and 55.1 Kg/km
Minimum Bending Radius	:- 8 X Cable OD (during installation) 4 X Cable OD (Installed)
Temperature Range	:- 0 to +50 degrees Celsius (Installation) -20 to +75 degrees Celsius (Operational)
Impedance	:- 100 ± 5 @ 1.0 MHz – 250 MHz
DC Loop Resistance	:- 300v/km maximum
Sheath	:- RAL 7037 GREY flame retardant PVC or HF*

Maximum Differential Propagation Delay (Skew)	:-	40 ns/100 m @ 100 MHz
Resistance Unbalance	:-	2% maximum
Capacitance Unbalance	:-	1600 pF/km maximum pair to ground
ACR Performance	:-	Positive ACR up to 550 MHz
Color Codes	:-	Pair 1 – White/Blue paired with Blue Pair 2 – White/Orange paired with Orange Pair 3 – White/Green paired with Green Pair 4 – White/Brown paired with Brown
Reference Standards	:-	ISO/IEC 11801 : 2002 ISO /IEC 61156-5 EN 50173-1 : 2002 EN 50288-6-1 ANSI/TIA/EIA 568B.2.1 : 2002
Others	:-	Independently verified by 3rd Party

8.5 OPTIC FIBER CABLE

- 8.5.1 Optic Fiber Cable (OFC) in this contract shall be suitable for underground installation.
- 8.5.2 The OFC shall be made off in a watertight box with mid-coupler couplings onto unjacketed ST-ST pigtails and patch cords shall be of the ST-ST duplex type where OFC is terminated.
- 8.5.3 The fiber patch cords shall be long enough to reach the fiber-to-copper Ethernet convertermodules in a cabinet or patch panel.
- 8.5.4 OFC entering cabinets shall be installed up into the cabinets and to one side of the cabinets, taking into account the minimum bending radius, and shall be housed in PVC wiring trucking and/or strapped to fixing positions in cabinets.
- 8.5.5 It is a requirement of this Contract that OFC ends be made off on site after the cables have beendrawn in. The making off of ends shall only be done by persons suitably qualified to undertake this type of work.
- 8.5.6 OFC shall comply with the following requirements:

General:

Specification:	OS1 (ISO/IEC)
Mode:	Single mode
Mode field diameter (optical):	9 ±3 µm
Cladding diameter (optical):	125±2 µm
Coating diameter (optical):	245±10 µm
Wavelength:	1310 and 1550 nm
Attenuation:	1.0 dB/km
Bandwidth:	1000 GHz
Impact resistance:	IEC 60794-1-E4
Resistance to water penetration:	IEC 60794-1-F4 – test method 5B
Fire conditions:	IEC 60332-3

Fiber core count:	4 (perimeter) / 12 (between buildings)
Identification:	Printing on cable sheath
Outer sheath:	Orange – flame retardant (Indoor cable)
<u>Underground OFC:</u>	
Armor:	Armor corrugated tape PE/FE/PE – longitudinally (Outdoor cable-Duct cable, Decabon armored)
Water absorbent tape:	Under CST
Cable bedding:	Black – flame retardant
Strength member:	Aramid yarns
Inner core:	Gel filled buffered tape
Inner 4 fibers:	Colored fibers (for ID purposes)
Sheath:	LSZH – black
Minimum bend radius:	300 mm
Length marking:	At 1 m ± 1 %.

9. POWER SUPPLIES

9.1 Mains Power Supply

9.1.1 The main power available is 230/415V, 3 phase, 4 wire, 50Hz.

9.1.2 The contractor shall make arrangements with City Power to obtain a connection point for supply to the UPS specified herein. The Contractor shall further, as part of the UPS installation provide external Class 2, MOV surge arrestors at the City Power circuit breaker feeding the UPS.

9.2 UPS SUPPLY

9.2.1 A UPS unit together with a power distribution panel is required to supply continuous power to the equipment which required a 230VAC supply in this project for a predetermined period, during a power failure- or power dip condition.

9.2.2 ~~The output rating of the UPS shall not be less than 4kVA and the battery capacity shall be rated for an 8~~
hour period at a full load. The exact UPS capacity shall be determined according to the requirements of each individual site. The UPS with battery pack shall be capable of being rack mounted with a maximum height of 3U for the UPS and 3U per battery pack.

9.2.3 The UPS shall be rated for a full 8 hour standby after a power failure has occurred, with all the 230VAC of the control equipment load online and on load with a dropout outgoing voltage of the UPS of not lower than 215 V AC, 50 Hz at the end of the 8-hour period.

9.2.4 The UPS shall be "Smart" type and shall further be of the "Double-Conversion" type whereby incoming AC is fed via a transformer to the delta inverter and also directly to the load side of the main inverter via the static switch facilities of the UPS. The delta and main inverters shall both supply rectified power to the bank of batteries. Both inverters shall thus supply power to the load. The static switchover shall provide "bump-less" transfer on power failure and no harmonics shall be fed back onto the supply to the UPS.

9.2.5 The unit shall supply power to the load at 100% of nominal voltage (230V) with an incoming voltage of 230 V ± 15% from the emergency power generating plant or the Municipal or Utility Supply.

9.2.6 The unit shall also be suitable to accept extended battery packs, if required in future.

9.2.7 "Brute Force" or single conversion UPS units shall not be acceptable.

- 9.2.8 Operating manuals, programming instructions (if applicable), drawings and diagrams shall be supplied with the UPS to enable the installer of the unit to install and commission the unit and to maintain the unit for the maintenance period and after the maintenance period.
- 9.2.9 The UPS equipment shall rack mounted and shall have the following equipment included in the cabinets:
- 9.2.10 UPS unit in a rack mount housing with ventilation punched slots in top and bottom on the frontdoor.
 - 9.2.10.1 1 x 32A SP, rotary handle operated, main isolator for the incoming supply.
 - 9.2.10.2 10 x 10A, 6kA single pole circuit breakers for outgoing supplies to the control roomequipment, field power supplies and future equipment.
 - 9.2.10.3 LED indicator lamp for INCOMING POWER ON.
 - 9.2.10.4 LED indicator lamp for UPS POWER OUTGOING POWER ON.
 - 9.2.10.5 Incoming and outgoing cables.
- 9.2.11 The batteries shall be rack mounted below the UPS rack.
- 9.2.12 The door of the board shall have pressed out louver type ventilation openings with 4 slots per opening and with fine brass mesh on the inside of the openings in a metal frame for vermin proofing.
- 9.2.13 All cable tails and wiring ends shall have pin lugs and wire numbers. All ends of wiring shall be pin lugged with insulation sleeves on the crimping portion of the pin lug. Pin lugs shall be of sufficient size to accommodate the wire sizes specified in this document and oversize pin lugs shall not be acceptable. Pin lugs shall not cause unnecessary strain on terminals or damage to terminals, even after the pin lug has been removed and inserted a few times.
- 9.2.14 The labels shall be of the Grafoplast print, which shall be housed in captive plastic sleeveholders on wires. 10 Digits shall also be allowed for per label for tender purposes.
- 9.2.15 The top- and bottom compartment doors shall be hinged and shall fit flush into the frame of the board.

Rack Mount UPS & Battery Pack

UPS:

Size:

3U Rack mountable

Output:

Output power capacity:

Equipment load for 8 hours

Min. Configurable Power (Watts):

4.0 kVA

Nominal Output Voltage:

230V

Output Voltage Distortion:

Less than 3%

Output Frequency (sync to mains):

50 Hz +/- 3 Hz user adjustable +/- 0.1

Topology:

Double Conversion Online

Waveform type:

Pure Sine wave

Output Connections:

(min. 2) IEC 320 C19 (Battery Backup)(min. 2) IEC 320 C13 (Battery Backup)

Bypass:

Internal Bypass (Automatic and Manual)

Input:

Nominal Input Voltage:

230V

Input frequency:

50 Hz +/- 5 Hz (auto sensing)

Input Connections:

IEC-320 C20

Input voltage range for main operations:

160 – 280 V

**SPECIFICATION FOR INTERGRATED
SECURITY SYSTEMS**

REFERENCE REV
CP_TSSPEC_237 **1**
PAGE 23 172

Number of Power Cords:	1
Rack Height:	Max. 3 U
<u>Battery:</u>	
Battery type:	Field replaceable, leak-proof, maintenance-free sealed Lead-Acid battery with suspended electrolyte
Expected Battery Life (years):	3 – 5
Typical recharge time:	Min. 2.5 hour(s)
<u>Communication:</u>	
Control panel:	LED/bar-graph status display with load, battery voltage and: <ul style="list-style-type: none"> - On Line - On Battery - Replace Battery - Overload - Bypass
Audible Alarm:	Alarm when: <ul style="list-style-type: none"> - on battery - low battery - overload
<u>Surge:</u>	External - Class 2, MOV
<u>Environmental:</u>	
Operating Temperature:	0 - 40 °C
Operating Relative Humidity:	0 - 95% no %
Operating Elevation:	0-3000 meters
Storage Temperature:	-15 - 45 °C
Storage Relative Humidity:	0 - 95% no %
Storage Elevation:	0-15000 meters
Audible noise at 1 meter from surface of unit:	55.0 dBA
Online thermal dissipation:	609.0 BTU/hr.
Protection Class:	IP 20
<u>Conformance:</u>	
Standard warranty:	2 years repair or replace
<u>Additional Battery Packs (if required):</u>	
Battery type:	Field replaceable, leak-proof, maintenance-free sealed Lead-Acid battery with suspended electrolyte
Battery mounting:	Stand-alone battery stack – rack mounted
Expected Battery Life (years):	3 – 5

9.3 POWER CABLE

9.3.1 Cables for 230VAC use shall be of the polyvinyl chloride insulated type shall have a single layer of steel wire armoring sheathed with a final layer of flame retardant polyvinyl chloride as per SANS 60332-1, SANS 60332-3-24, SANS 6139 and with the specifications of the cable at regular distance along the outer sleeve.

-
- 9.3.2 Power cable shall be of the red line type and shall comply with SANS 1507 specifications.
- 9.3.3 Power cable for single phase use shall be 600/1000V rated, 3 core type with the standard colors of blue for neutral, brown for line and green/yellow for earth.
- 9.3.4 Power supply cable installed in buildings shall not have a current rating of less than 20A. Underground power cable to outdoor equipment shall not have a current rating of less than 25A.
- 9.3.5 In addition to SANS10142-1 no power circuits shall have a voltage drop exceeding 5% of nominal voltage.
- 9.3.6 The use of flexible conduit not exceeding a 1m length shall be permitted in device circuits.
- 9.3.7 Power cable in buildings shall be installed in 25mm Ø electro-galvanized conduit and draw boxes with the conduit mounted on electro-galvanized spacer saddles at distances of not more than 1,5m apart.
- 9.3.8 Power cable shall be terminated in cabinets with suitable compression glands

10. ACCESS CONTROL SYSTEM

10.1 GENERAL REQUIREMENTS

- 10.1.1 The access control system shall consist of card readers, card reader controller equipment, digital input equipment for PIR's (where required), door hold magnets (where required), door monitor switches, Rex buttons as required and power supply equipment.
- 10.1.2 The system shall operate the door locking devices and/or monitor designated doors in response to an authorized access card being presented to a card reader. The door shall remain unlocked for a pre-programmed time.
- 10.1.3 If a monitored door is not closed and latched within a pre-determined time after it has been opened, a 'door held' alarm condition shall be initiated, the associated horn device shall be activated, and a signal shall be transmitted via the local control equipment to the central control centre or to the designated control room as required by City Power. Refer to "19.2 Digital Input Control Modules" for the requirements of "door held alarm" equipment.
- 10.1.4 An alarm shall be generated when the respective door has been opened or has been held open and/or not latched for a period of time greater than a programmed period of delay. The door open alarm condition shall reset automatically when the door is closed and the lock properly engaged within the abovementioned delay period.
- 10.1.5 Interconnected integral request-for-exit (REX) switches shall permit exit through the associated door without creating a door forced or door held alarm or unlocking of door and requiring no special knowledge or action.
- 10.1.6 Refer to clause "*Error! Reference source not found. Error! Reference source not found.*" for installation of wiring and cables in conduit systems.
- 10.1.7 Five different access control door types have been defined on these project:

**SPECIFICATION FOR INTERGRATED
SECURITY SYSTEMS**

REFERENCE

REV

CP_TSSPEC_237

1

PAGE

25

172

-
- 10.1.7.1 Door Type A – Card Reader IN – Push Button OUT
 - 10.1.7.2 Door Type B – Card Reader IN – Card Reader OUT
 - 10.1.7.3 Door Type C – Biometric Reader IN – Push Button OUT
 - 10.1.7.4 Door Type D – Biometric Reader IN – Biometric Reader OUT
 - 10.1.7.5 Door Type E – No Access Control, monitoring only

Diagrams of these Door types are illustrated below:









	PUSH BUTTON EXIT
	DOOR RELEASE / BREAK GLASS (GREEN)
	FIRE BREAK GLASS UNIT (RED)
	CARD READER
	COMBINED MAGNETIC LOCK AND DOOR MONITOR
	MAGNETIC LOCK
	DOOR MONITOR
	BIOMETRIC READER

Figure 1: Symbol legend for door types

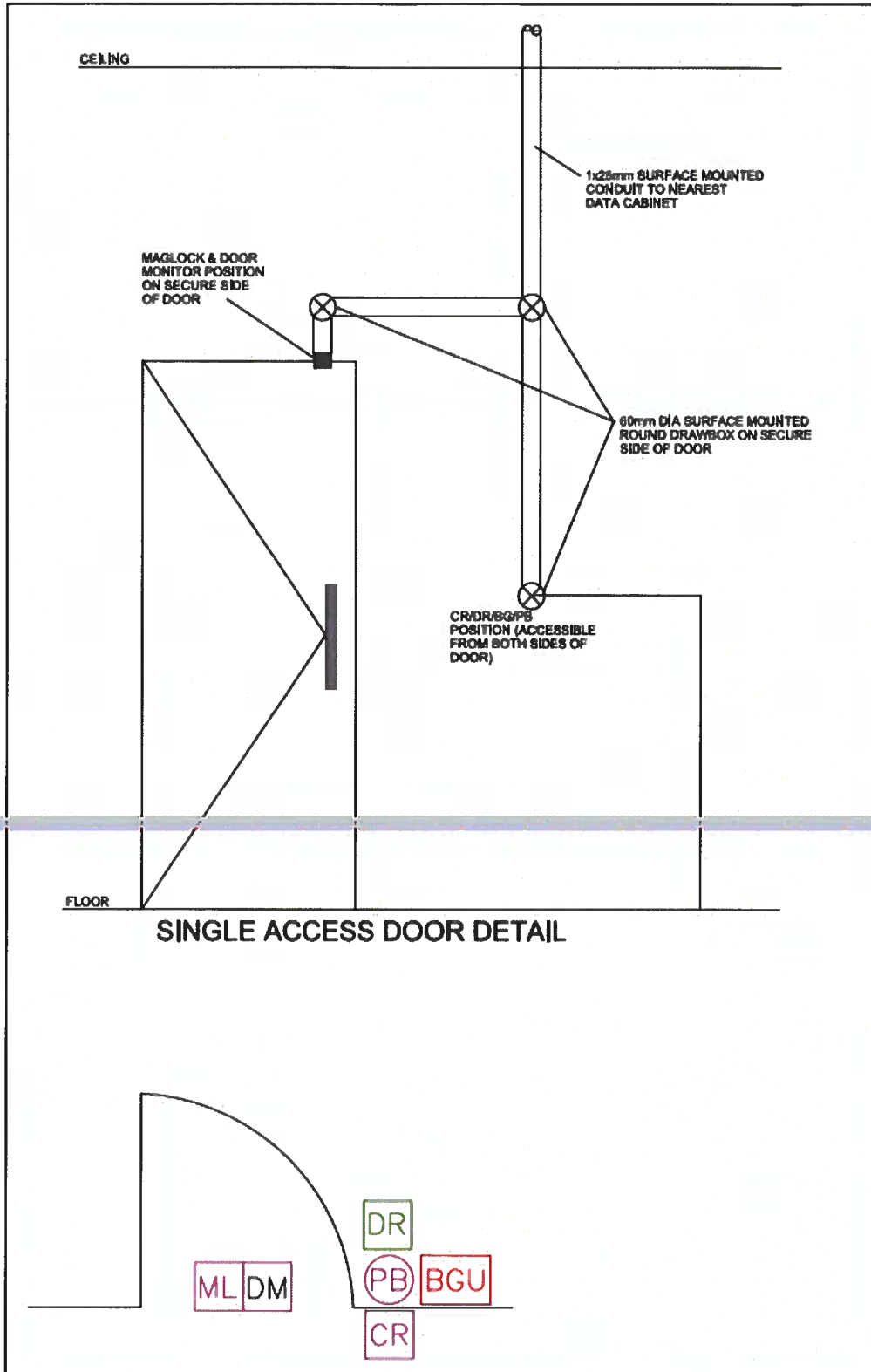

Figure 2: Door type A1

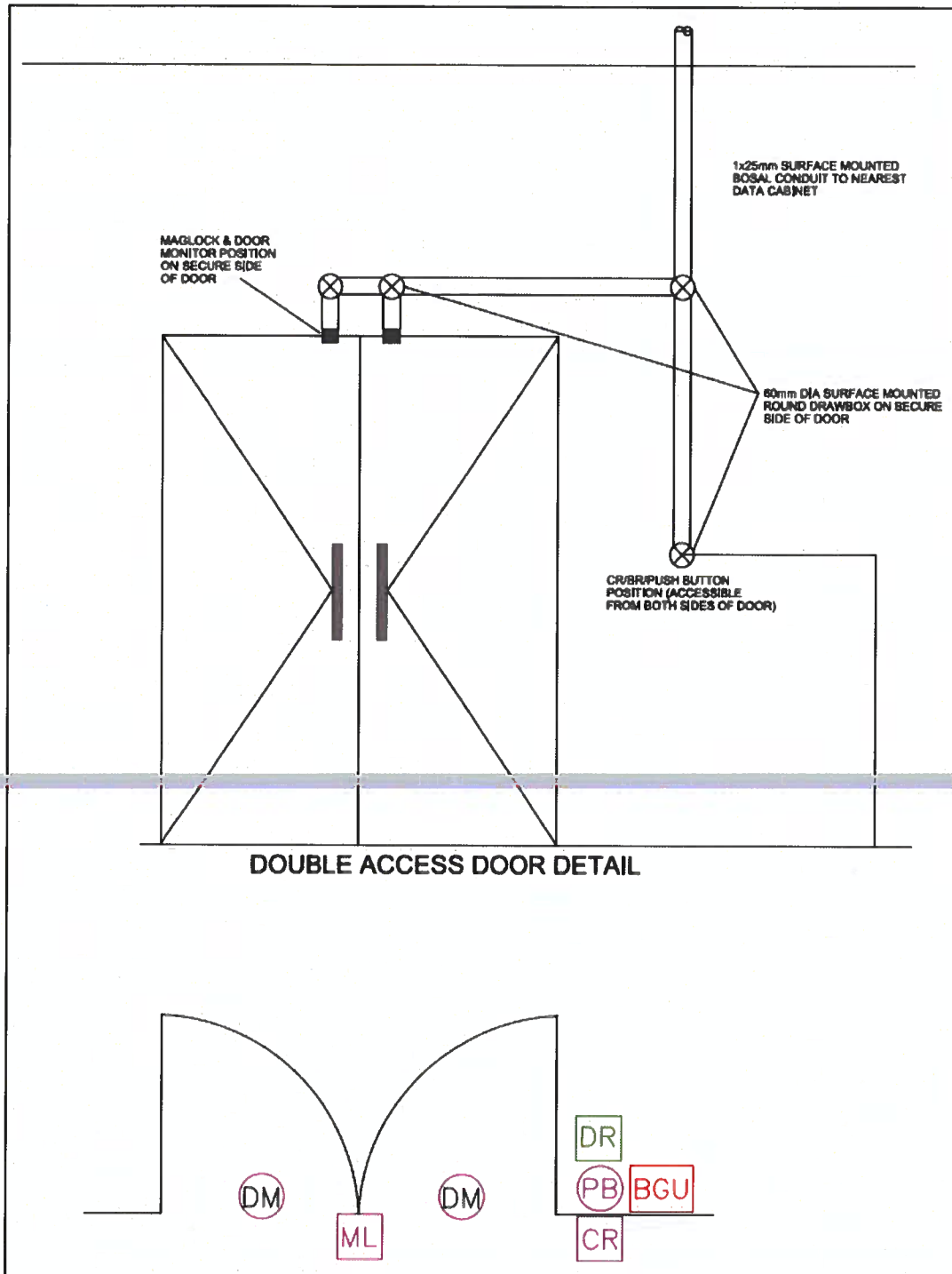

Figure 3: Door type A2

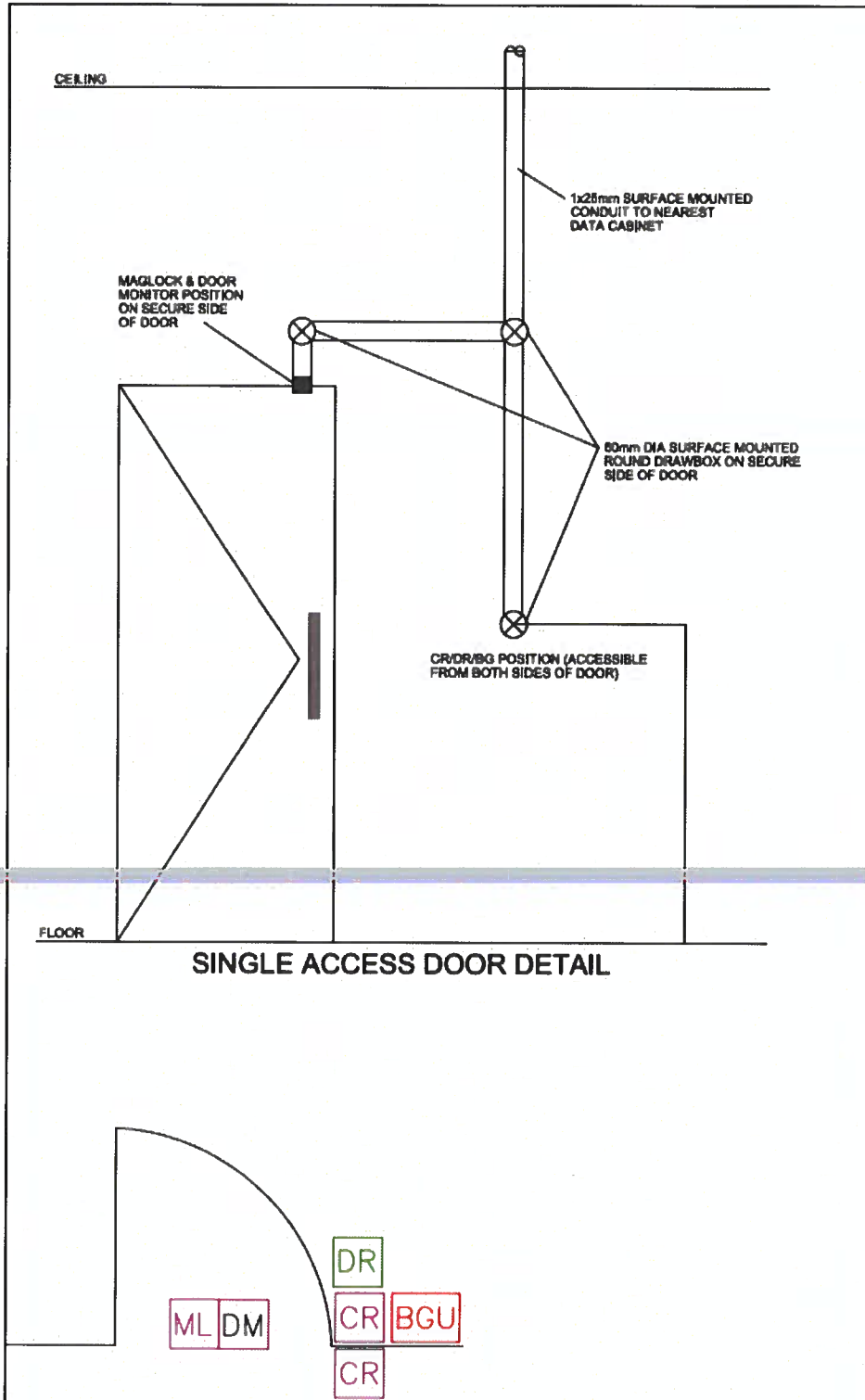

Figure 4: Door type B1

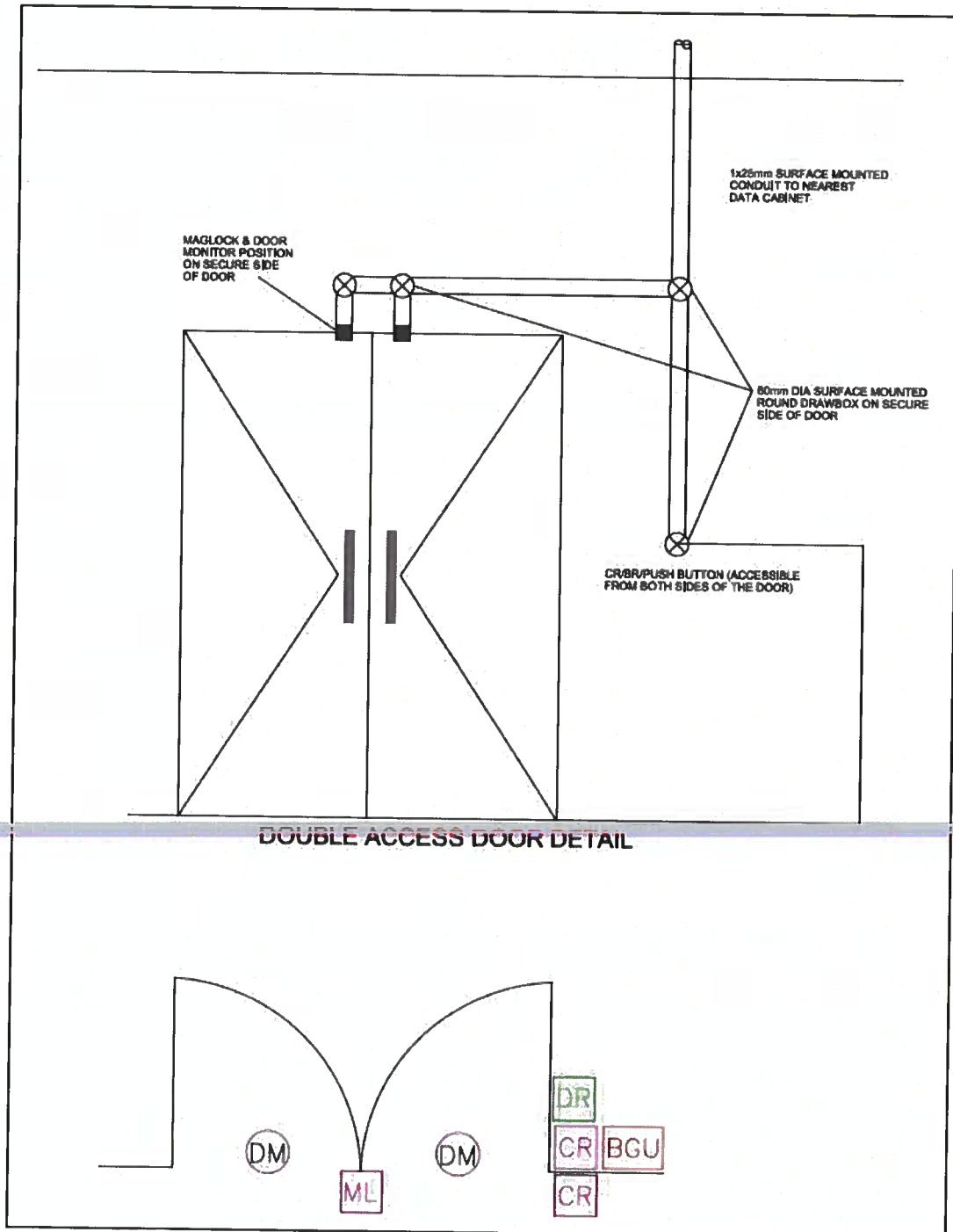

Figure 5: Door type B2

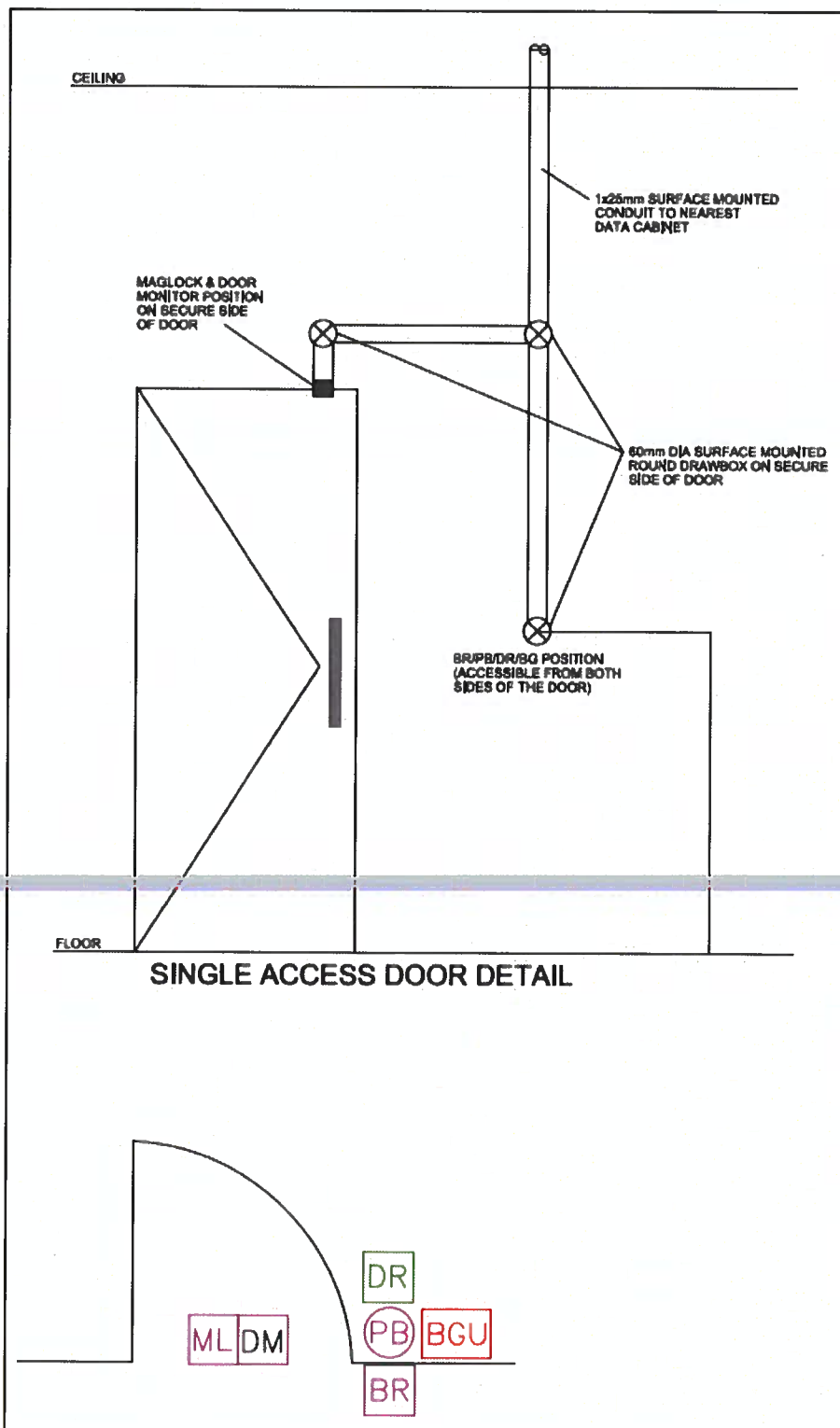

Figure 6: Door type C1

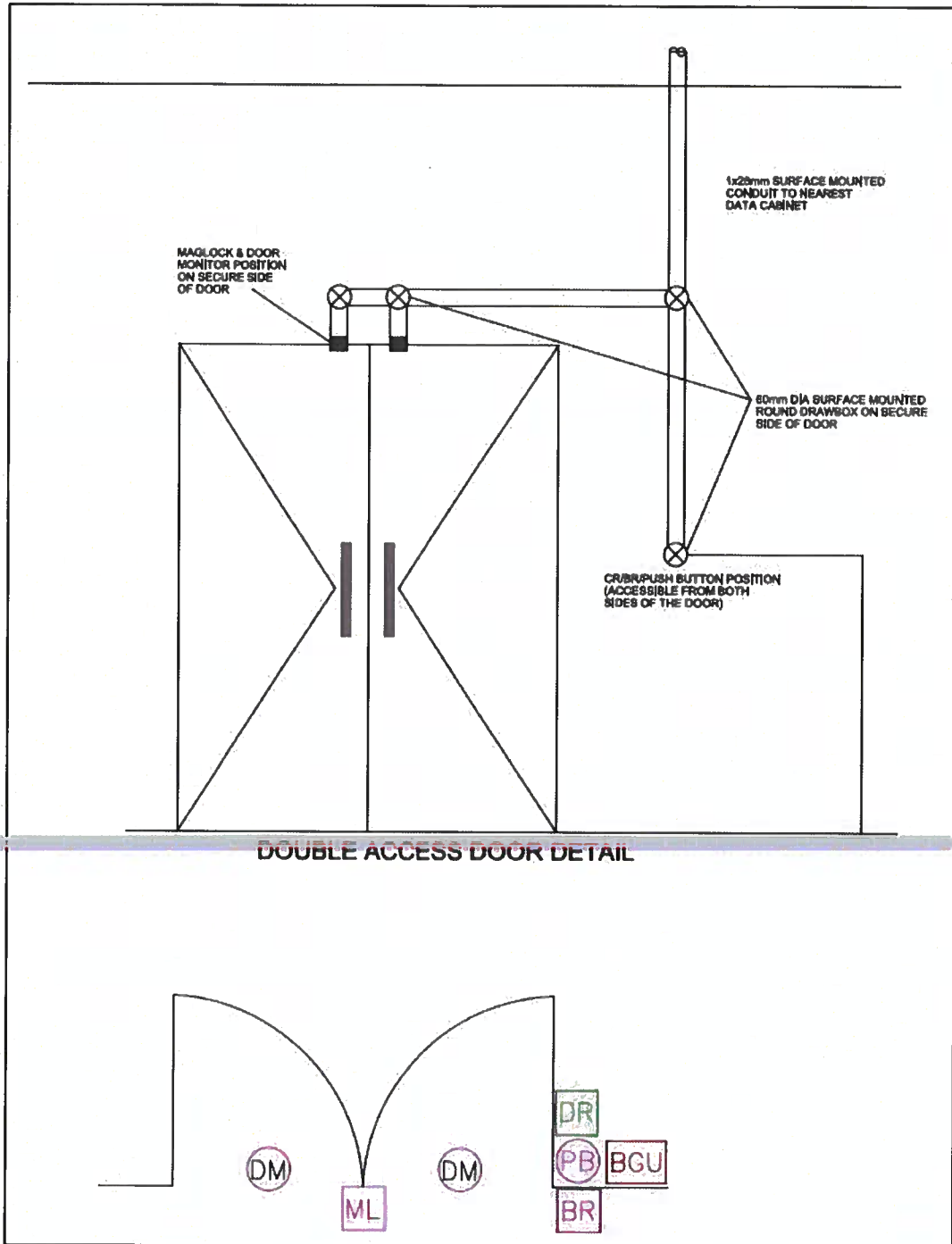
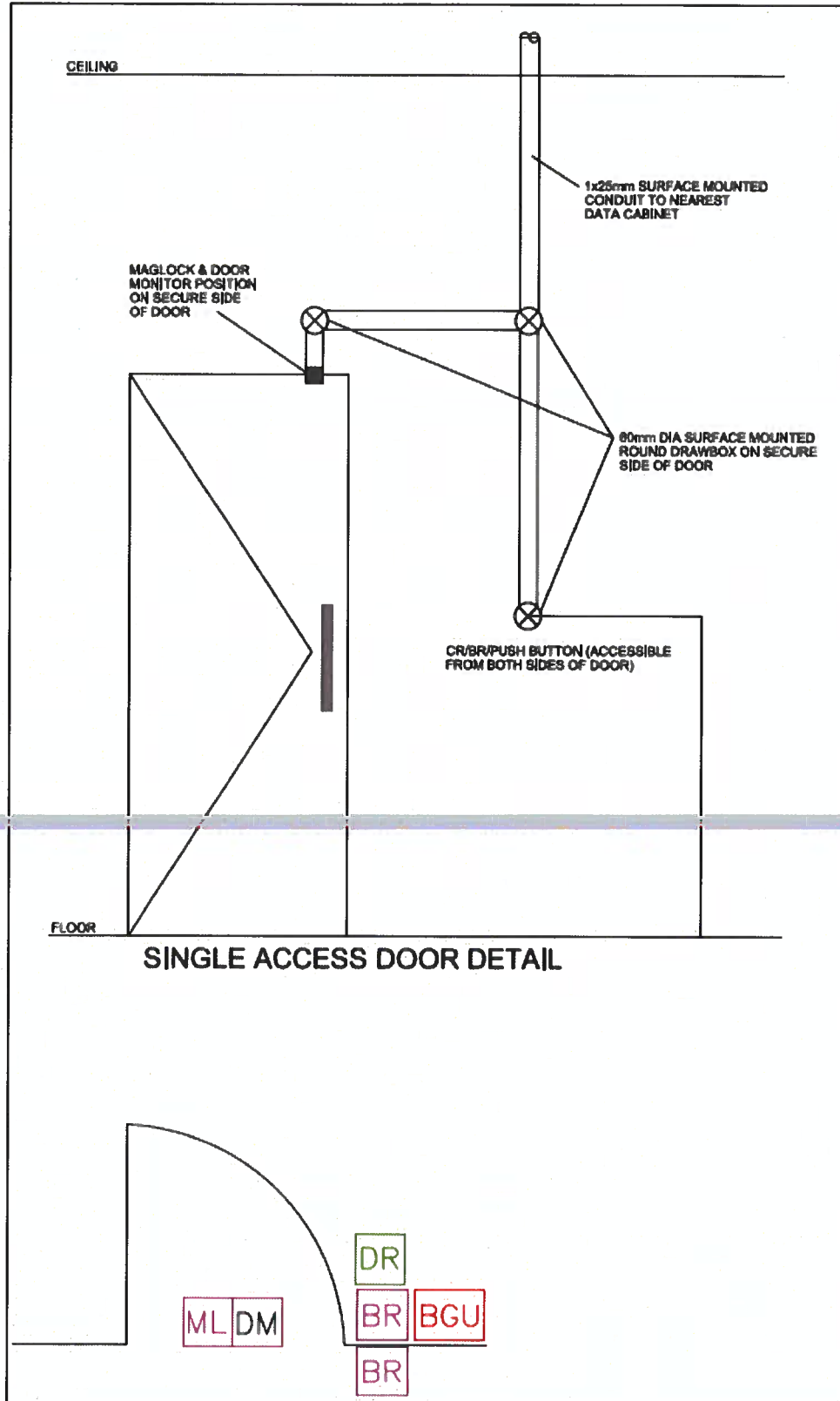

Figure 7: Door type C2

Figure 8: Door type D1



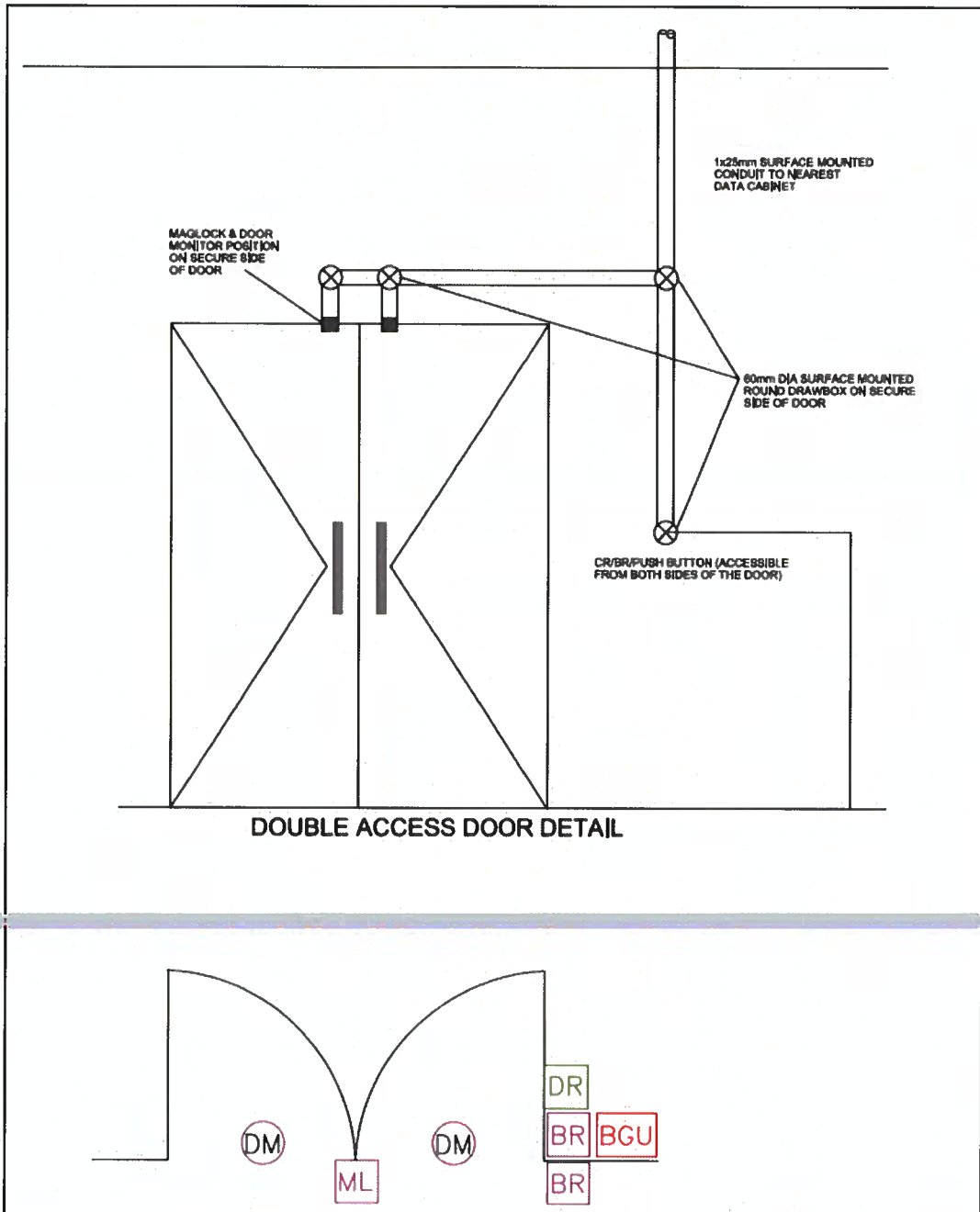

Figure 9: Door type D2

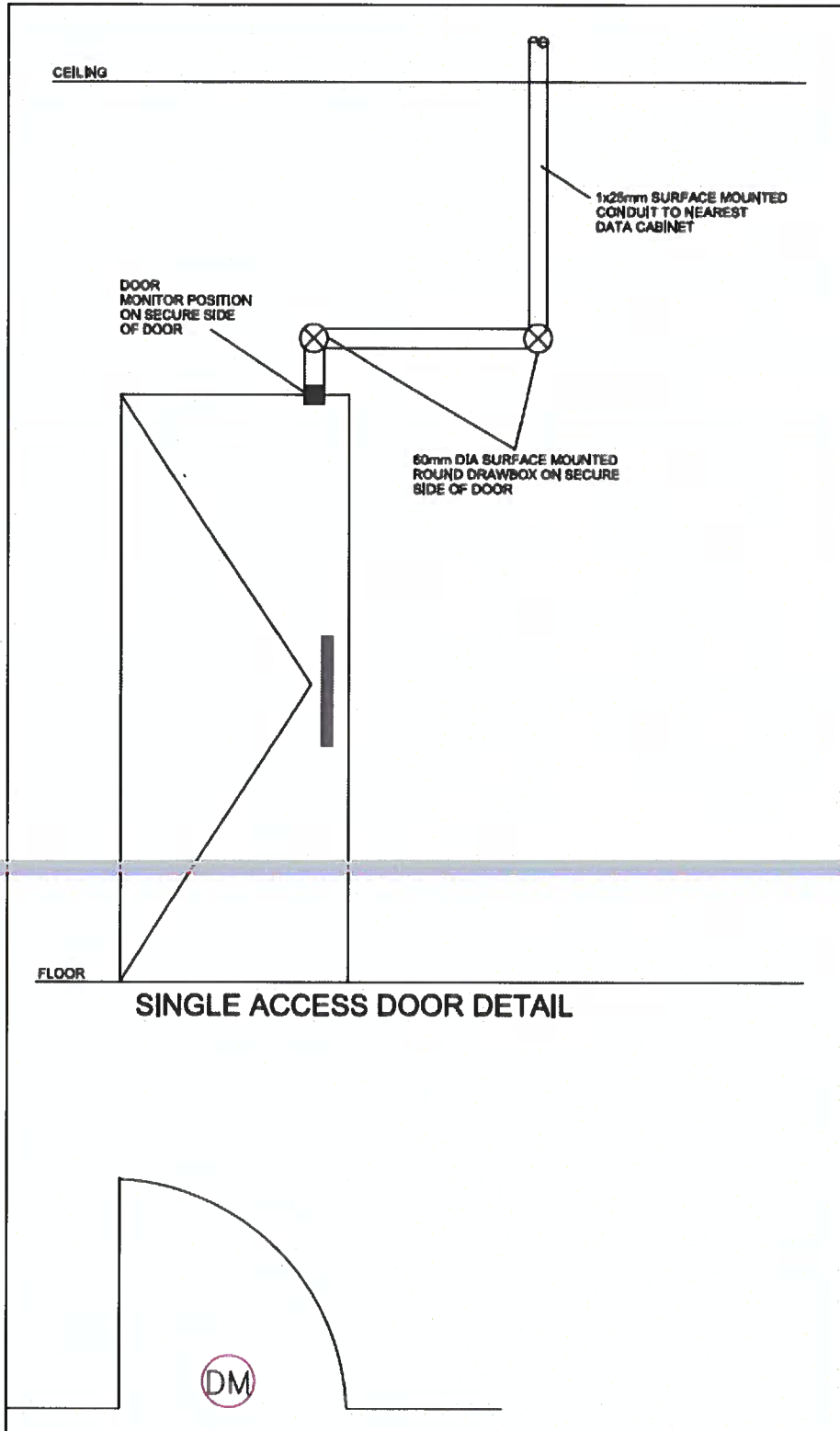

Figure 10: Door type E1

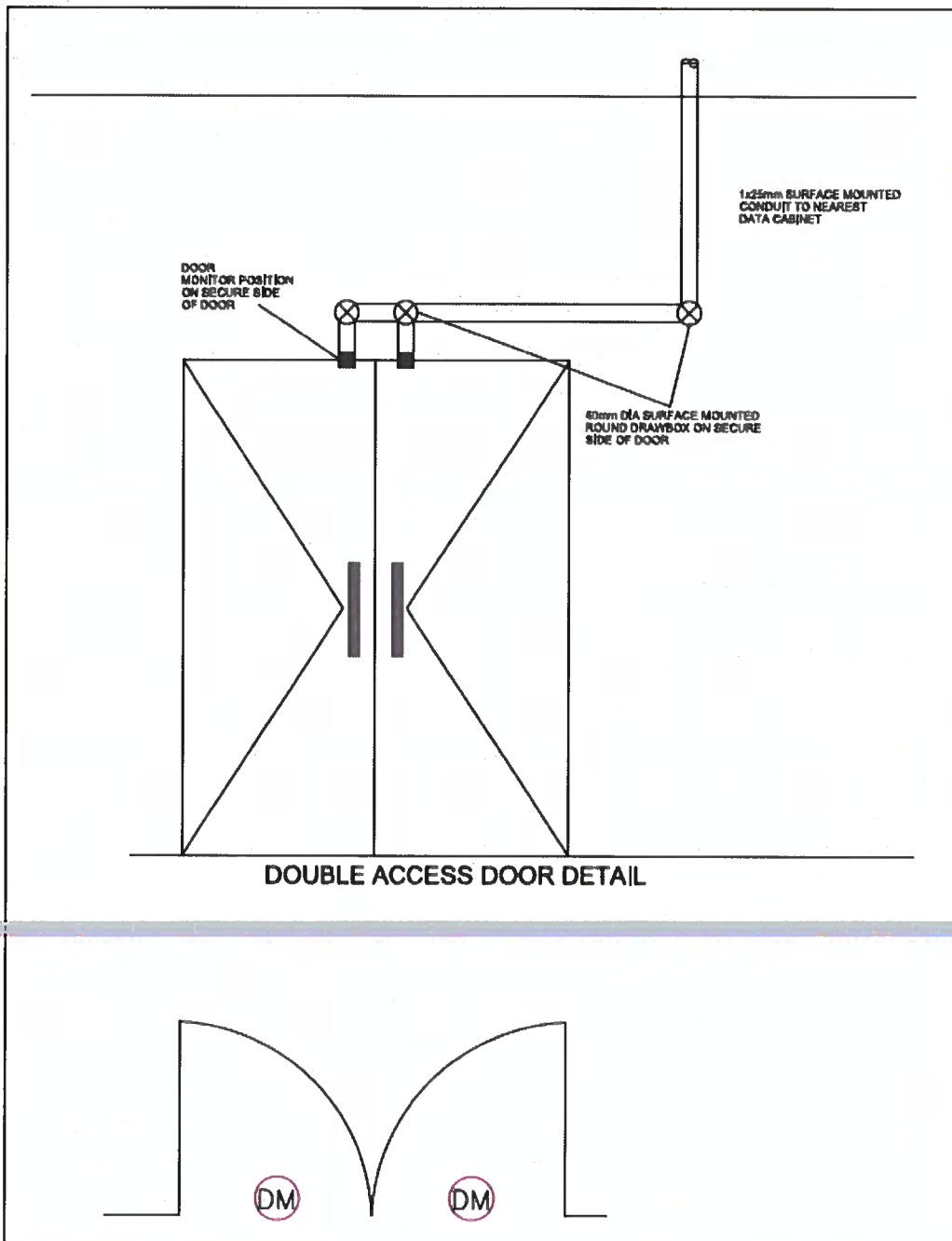

Figure 11: Door type E2

10.2 SYSTEM INTERFACE CONTROLLER

- 10.2.1 The System Interface Controller (SIC) in the specifications and as required in this contract shall interface Door Reader Controller (DRC) cards on the City Power security management system platform.
- 10.2.2 The SIC shall have two on-board reader ports and shall support standard Wiegand Data1/Data0 and Clock/Data communication and bidirectional RS-485 Open Supervised
- 10.2.3 Device Protocol (OSDP) for two standalone card readers or combinations of card reader/keypads and shall further support DHCP and fixed IP address devices.
- 10.2.4 The SIC shall also referred to as the "system controller" for an integrated system on a particular site.
- 10.2.5 Card readers and other equipment which shall be connected to, and operated with the SIC are specified further herein.
- 10.2.6 The SIC shall have an On-board Ethernet10/100Base-T high speed port for a TCP/IP network and shall communicate downstream via a multi-drop RS485 communications channel with Bioscrypt RS485 2-wire, 115,2 kbps devices.
- 10.2.7 The SIC shall support a maximum of 32 devices downstream and shall have 6Mb card holder flash memory for 50 000 events.
- 10.2.8 A port for RS-232 communication shall also be provided on the controller.
- 10.2.9 The card shall have 8 inputs and 4 outputs and shall a 3V lithium battery with a 5 year lifetime.
- 10.2.10 The 8 inputs shall be suitable for normally open, normally closed, supervised and un-supervised circuits and shall in addition have 4 form-C 5A output relays
- 10.2.11 The controller shall be suitable for 24VDC supply.
- 10.2.12 The device shall be UL 294 and UL 1076 compliant.
- 10.2.13 The SIC shall be cabinet mounted and shall have dedicated cabinet tamper and power fault input monitor facilities. The IRDC is normally mounted at or in the digital video recorder rack in the control room of the site.

DC input:	24 VDC ± 15%. 500 mA maximum
Memory and Clock backup:	3 V lithium, type CR2330
<u>Communication Ports:</u>	
Primary (Ethernet) Port:	10/100Base-T Ethernet high-speed port
Alternate Upstream Port 1:	RS-232 9600 to 115.2 Kbps a sync
Downstream Port 2:	RS-485 (2-wire) 9600 to 38.4 Kbps async
<u>Inputs:</u>	
Tamper and Power Fail Monitors:	Unsupervised, dedicated
Door position, REX, and AUX:	8, each programmable as normally open or normally closed, supervised or unsupervised circuits
<u>Outputs:</u>	
Relay outputs:	4 Form-C 5 A at 30 VDC relay outputs: 2 strike, 2 auxiliary
Reader Power:	
DC output:	24VDC, 125 mA regulated
Reader Port Compatibility:	Wiegand Data1/Data0, Magnetic Clock/Data, F/2F single-

wire protocol, Bioscrypt RS-485
OSDP (Open Supervised Device Protocol RS-485)

Environmental:

Temperature:

Operating: 0° to +70° C
Storage: -55° to +85° C

Humidity:

0 to 95% RHNC

Mechanical:

Approvals:

UL 294, CE-marked, RoHS compliant
FCC Part 15, CE, RoHS, UL 294, UL 1076,
ULC CSA-C22.2, CAN/ULC-S319-05, cUL/ORD-C1076

10.3 DOOR READER CONTROLLER

- 10.3.1 The Door Reader Controller board (DRC) shall be of the Series 2 type and shall support standard Wiegand Data1/Data0 or Clock/Data communication and bidirectional RS-485 Open Supervised Device Protocol (OSDP) for readers and keypads.
- 10.3.2 The card reader controller interface board shall be suitable to handle two card reader i.e. 2 single doors or two double doors or one single and one double door card reader.
- 10.3.3 The DRC shall have an on-board voltage regulator, which shall be suitable to transform a 24VDC supply to 24VDC for the DRI.
- 10.3.4 Lock, unlock, and facility code offline access modes shall be supported of all readers connected to the DRI. Each DRC shall support 16 different card formats (8 card formats and 8 asset formats) as well as issue codes for both magnetic and Wiegand card formats. And the DRC
- 10.3.5 The DRC shall provide a link between the System Interface Controller (SIC) and the card reader attached to the interface.
- 10.3.6 The DRC modules shall be suitable to be multi-dropped upstream and/or downstream from the interface using RS-485 2-wire or 4-wire communication of up to 1200m per port away from the SIC to which the DRI's are connected.
- 10.3.7 The DRC module shall be suitable to be individually addressed for increased reporting capabilities with the existing security management system access control software applications.
- 10.3.8 The DRC shall include a minimum of 8 inputs that support normally open, normally closed, supervised, and non-supervised circuits and in addition shall have a minimum 6x5A, form C, output relays which support failsafe or fail-secure operation.
- 10.3.9 The DRC shall have DIP switches for selectable addressing and on-board jumpers for termination.
- 10.3.10 The DRC shall thus further have the following features:
- 10.3.10.1 Shall have dedicated tamper and power failure circuits
- 10.3.10.2 Shall be suitable to mount in a steel enclosure using insulated stand-off posts.
- 10.3.10.3 Shall comply with SANS10222-1/2, UL294 and shall be a 1076 listed device.
- 10.3.11 The DRC circuit board shall be mounted in the 230V,24VDC enclosure which supplies the door operating hardware with power. The power supply enclosure shall thus be suitable to mount a minimum of 6 cards.

10.3.12 Other cards such as digital input cards can also be mounted in the same enclosure as the DRC cards.

Primary Power: 24VDC \pm 10%
Outputs: 6 outputs, Form-C, 5A @ 28Vdc, resistive
Inputs: 8 unsupervised/supervised, standard EOL: 1k/1k ohm, 1% 1/4 watt
2 unsupervised, dedicated for cabinet tamper and UPS fault monitoring
Reader Interface: Reader power: 24Vdc \pm 10% regulated, 125mA maximum each reader
Reader Port Compatibility: Wiegand Data 1/Data 0
Magnetic Clock/Data
F/2F Single Wire
Open Supervised Device Protocol
Environmental Temperature: Operating: 0°C to +70°C
Storage: -55°C to +85°C
Humidity: 0% to 95% RHNC
Compliance Approvals: FCC Part 15, CE, RoHS, UL 294, UL 1076, ULC CSA-C22.2, CAN/ULC-S319-05, cUL/ORD-C1076

10.4 DOOR READER CONTROL POWER SUPPLY

10.4.1 The power supply for DRC cards or for high power magnets shall be of the 230VAC, 50Hz input and 24VDC selectable output voltage type and shall be complete with a 7Ah battery.

10.4.2 The power supply shall be mounted in a powder coated steel enclosure with a hinged door and with sufficient space to mount 6 interface cards of the DRC or digital input type, mounted on insulated stand-off supports, and shall be rated as Class 2 and shall be CE marked.

10.4.3 The charger shall use modular PC boards mounted on stand-off insulated posts for ease of replacement in case of a card failure.

10.4.4 The output DC voltage connection terminal board shall be separate from the AC to DC board. Positive and negative connections terminals shall be clearly printed on the DC output board and the 230VAC input terminals shall be clearly marked and shall not be placed next to DC terminals.

10.4.5 The power supply shall have a built-in charger for a 24Volt gel type battery and the power shall automatically transfer to battery power upon AC input failure and the unit shall further have thermal overload protection. The charger shall have an open frame transformer.

10.4.6 The peak output DC voltage ripple of the power supply shall be not more than 100mV and the unit shall have a rating of at least 400VA.

10.4.7 NOTE: Separate power supplies shall be used to energize door holding magnets so as not to overload DRC power supplies.

10.4.8 The housing shall incorporate a tamper switch and shall further be fitted with a lock and 2 keys. The housing door shall have AC input and DC output indication LED lamps.

10.4.9 AC fail indication monitoring contacts and terminals shall be provided on the charger and low battery shutdown shall be provided to prevent deep discharge of the battery.

10.4.10 The charger cabinet shall be wall mounted next to a door at a suitable height for ease of

maintenance. Charger cabinets shall only be mounted internally to buildings. Charger cabinets shall be firmly fixed with at least 4 x 6mm expanding type bolts. Fixings shall only be done into bricks on walls to ensure proper fixing. The charger cabinet shall have a wiring diagram plaque on the inside of the door.

10.4.11 The positions of power supplies are shown on the layout drawings accompanying this specification.

Power Output: 24VDC
Rating: Class 2 Rated
Power Input: 230 VAC, 60 Hz, 1.9 amp
Maximum Charge Current: 0.7 amp
 Filtered and electronically regulated outputs
 Built-in charger for sealed gel type batteries
 100 mV peak output voltage ripple

Dimensions:

Power supply board dimensions: 108 x 178 x 44mm
Enclosure dimensions: 610 x 457 x 114mm
Approvals: CE-Marked

10.4.12 DOOR CONTROLLER POWER SUPPLY

Input Voltage: 230 VAC, 50 Hz $\pm 10\%$
Output Voltage: 27.6 VDC
Load output: 4 A
Total output: 5 A
Output ripple: Max. 100mVrms
Max. Battery size: 7Ah (x2)
Battery recharge time: 20
Battery disconnect voltage: 19.6 ± 0.2 VDC
Open collector output: Open circuit on

Load output: 4 A
Total output: 5 A
Output ripple: Max. 100mVrms
Max. Battery size: 7Ah (x2)
Battery recharge time: 20
Battery disconnect voltage: 19.6 ± 0.2 VDC
Open collector output: Open circuit on fault or mains fail
Fuse 24V output: 5 A
Fuse 230 VAC input: 3.15 A
Operating temperature: -10 to +40°C
Relative humidity: 95%
Housing (steel) powder coated: 1.2 mm

10.5 CARD READERS

10.5.1 Card readers shall be HID global iClass+ SIO type compliant, shall be able to interface to the Wiegand and Open Supervised Device Protocol (OSDP) interface type, and shall be suitable for bi-directional communication.

10.5.2 The reader shall support multiple technology card platforms and shall have downloadable firmware.

SPECIFICATION FOR INTERGRATED SECURITY SYSTEMS

REFERENCE

REV

CP_TSSPEC_237

1

PAGE

41

172

- 10.5.3 Card readers shall further support Near Field Communication (NFC) smart phones via Seos for portable identity credential use.
- 10.5.4 Card readers shall be of the contactless type (ISO15693) and shall be of the read-only type.
- 10.5.5 Card readers shall be Mini-Mullion size and shall be suitable for mounting on mullion framedoors or on a standard door switch box or on surfaces of walls.
- 10.5.6 Card readers shall be suitable for a 5v to 16v DC linear power supply and have dedicated tamperand power failure circuits.
- 10.5.7 The card reader outer casing shall be of the UL Polycarbonate type and shall be IP55 rated.
- 10.5.8 Readers installed in positions which shall expose the reader to vandalism, the unit shall be mounted in a single indestructible metal weatherproof housing rated at IP55.
- 10.5.9 Clear indications of the status of the unit shall be in the form of LED type and shall indicate withred flashing indication and buzzer and green ON signals.
- 10.5.10 Card readers shall be fixed to with tamper proof screws or fixings.
- 10.5.11 Card readers shall be installed at a height of 1200mm above finished floor level or at the sameheight above finished floor level or at the height of existing fire detection or access control equipment.
- 10.5.12 The card readers positions shall be outlined the layout drawings accompanying this specification.
- 10.5.13 At the depot's vehicle entrance and exit a double set of card readers shall be installed, with the higher level card reader fortruck access and the lower level card reader for vehicleaccess.

Mounting:	Mini-Mullion Size; physically HID's smallest iCLASS® readers
Color:	Black
Material:	UL94 Polycarbonate
Panel Connection:	Pigtail or Terminal strip depending on product type
Power Supply:	5 - 16 VDC Linear Supply recommended
Standard Power Mode:	
Current Requirements:	45/75 mA @ 24 VDC Avg/Peak 13.56 MHz Card Compatibility Secure Identity Object™ (SIO) on iCLASS SE/SR, SE for MIFARE DESFire EV1 and SE for MIFARE Classic (On by Default) Standard iCLASS Access Control Application (order with Standard interpreter) ISO14443A (MIFARE) CSN, ISO14443B CSN, ISO15693 CSN Typical Maximum Read Range
13.56 MHz Single Technology:	iCLASS® SETM: 7.1cm
ID-1 Credentials (Cards):	SE for DESFire® EV1: 4.1 cm
SIO Data Model:	SE for MIFARE® Classic: 6.6cm
13.56 MHz Single Technology:	iCLASS SE: 3.8cm Tags/Fobs
– SIO data Model:	SE for MIFARE Classic: 3.0cm
Cable Distance:	150m
Operating Temperature:	-35°C to 65°C
Relative humidity non-condensing:	5% to 95%
Transmit Frequency:	13.56 MHz
Interface:	Wiegand and OSDP depending on product type
Environmental Rating:	IP55
HID Patent:	US7124943, US6058481, US6337619

10.6 EMERGENCY EXIT BREAKGLASS

- 10.6.1 The emergency exit break glass required in this contract shall be of the surface mounted type and the outer casing shall be finished in a green color.
- 10.6.2 The button shall have an SANS50054-11 compliant break glass front and shall have normally open and normally closed change-over contacts and the connection terminals shall be suitable for 0,5 — 2,5mm² wiring.
- 10.6.3 The unit shall further have test key facilities and shall be of IP24D rating.
- 10.6.4 Emergency exit break glass shall be installed next to escape doors to allow the opening of the door in case of an emergency.
- 10.6.5 The break glass shall be wired into the magnetic lock power supply circuit and shall release the magnetic locks when pressed at the particular door.
- 10.6.6 Emergency exit break glass shall be installed at a height of 1200mm above finished floor level or at the height of existing fire detection or access control equipment.
- 10.6.7 The emergency exit break glass shall be positioned as detailed in the drawings attached to this specification.

Cable Termination: 0.5 – 2.5 mm²

Max. contact rating: 2A @ 30 VDC

Mechanical:

Material: PC/ABS

Color: Green

Environmental:

Operating temperature: -10°C to +55°C

Storage temperature: -10°C to +55°C

Relative humidity: 0-95%

IP Rating: IP24D

10.7 REQUEST FOR EXIT BUTTON

- 10.7.1 The Request to Exit (REX) buttons required in this contract shall be of the surface mounted type and the outer casing shall be finished in a suitable color.
- 10.7.2 The button shall be marked with a key symbol and shall have normally open contacts and the connection terminals shall be suitable for 0,5 — 2,5mm² wiring.
- 10.7.3 The button contacts shall be of the momentary pulse type. The pulse shall de-bounced and shall be of a suitable duration to activate the Door Reader Controller (DRC) board controlling the particular door.
- 10.7.4 REX buttons shall be installed at a height of 1200mm above finished floor level or at the height of existing fire detection or access control equipment.
- 10.7.5 REX button shall preferably be of non-touch hovering type

10.8 ELECTRO MAGNETIC LOCK

- 10.8.1 The electro-magnetic locks in this contract shall be of 300 kg holding power type, for use on internal and external doors, and shall be of the monitored change-over type. Electromagnetic locks shall have tamper proof contacts which shall be wired to the digital control module of the particular door as described in clause "19.1 General" hereof too

**SPECIFICATION FOR INTERGRATED
SECURITY SYSTEMS**

REFERENCE

REV

CP_TSSPEC_237

1

PAGE

43

172

-
- 10.8.2 The units shall be of the state of the art electro-magnetic type that provides for positive and instantaneous door control and shall further be of the surface mounted type with backbox and 5mm plate.
 - 10.8.3 Magnets shall be installed on the secure side of doors, shall be inherently fail-safe, shall release instantly upon command or loss of power and shall not be of the residual magnetism type.
 - 10.8.4 Magnets shall be powered with dedicated battery back-up power supplies via the C-type relays of DRI's or digital cards.
 - 10.8.5 Magnets shall be suitable to operate from a 24VDC power supply (jumper selectable) and shall have bi-colored LED's to indicate the locking status.
 - 10.8.6 The unit shall not draw more than 450mA at 24 VDC supply voltage.
 - 10.8.7 Filler plates for the mounting of the magnet shall be installed to ensure proper mating of the magnet and holding plate, where applicable.
 - 10.8.8 Brackets of the L-type or Z-type shall be installed for the mounting on particular doors as shall be required.
 - 10.8.9 The mounting of magnets on fire doors shall not jeopardize the door's fire rating.
 - 10.8.10 The positions of magnets are shown on the layout drawings accompanying this specification.

Mount:	Surface
Holding force:	300 kg
Input Voltage:	24VDC
Current draw:	440 mA ($\pm 2.5\%$ @ 13.5 V)
Bi color LED:	Yes
Door status switch:	No
Monitored changeover:	Yes
Magnetic bond sensor:	Yes

10.9 DOOR CLOSERS

- 10.9.1 The door closers shall be of the surface mounted type and shall be mounted on the secure side of the door.
- 10.9.2 The units shall be suitable to operate doors to a maximum weight of 60 Kg.
- 10.9.3 The door closer shall have an adjustable arm and shall have a valve for the speed of closing and a valve for final slam operation.
- 10.9.4 The unit shall have the adjusting facility to keep the door open.
- 10.9.5 The closer arm and operating unit shall be fixed to the door and its frame with anti-tamper fixings.
- 10.9.6 The fixings on to hollow core doors (where applicable) shall not be on the thin shell of the door. Hollow core doors without inner solid wood shall be altered by adding a solid block of wood internally to the door structure at the top of the door.
- 10.9.7 Fixings into aluminum frames and steel doors and steel frames shall be done with suitable tapped screws, through bolts and nuts or butterfly type fixings.
- 10.9.8 Through bolting of steel doors at substations shall be done so that the bolt head is on the outside of the door. Nuts, in this case, shall be sealed with thread locking liquid. 43
- 10.9.9 At Depot's door closers shall be installed on every door controlled by a Magnetic Lock.

-
- 10.9.10 Door closer's Doorclosers at Substations shall only be installed if specifically requested.

10.10 DOOR MONITOR

- 10.10.1 Door monitor magnets shall be of the surface mounted type with the magnet mounted on the door frame and the contact plate on the door.
- 10.10.2 The door monitor shall have a contact which shall open when the gap between the magnet and the striker plate on the door is more than 18mm.
- 10.10.3 The magnet and strike plate shall be mounted near the lock side of the door with anti-tamper screws.
- 10.10.4 The magnets shall be for single swing doors and double leaf doors.
- 10.10.5 The wiring from the magnet to the connection box above the doorframe shall be as short as possible.
- 10.10.6 Magnets shall be wired to the Door Reader Controller (DRC) board that controls the door with double doors having their door monitors wired in series.
- 10.10.7 The wiring installation shall be from the connection box above the door to the housing of the DRC board and laid inside the conduit.
- 10.10.8 The positioning of door magnets shall be detailed in drawings attached to this specification.

10.11 VISITOR MANAGEMENT SCANNER

The integration between the driver's license scanner and the visitor management shall be such that it can perform the following electronically:

- 10.11.1 Transfer the information from the driver's license and license disk to the visitors management database either directly using Wi-Fi
- 10.11.2 Be capable of manually storing the information on the scanner and uploading it to the database when the unit plugged into a USB port on the workstation.
- 10.11.3 The information to be uploaded to the integrated security system's visitors management database shall be selectable, i.e. if certain information is not required such as VIN number of the vehicle, by deselecting this field on the interface, this information shall not be sent to the visitors management database and shall be disregarded.
- 10.11.4 Should an individual visit the client more than once, duplicate visitor records should not be created for that individual, however all relevant information such as the date and time of the visit shall be recorded.

Core:

RAM:

8MB

Serial Flash:

4MB

Flash:

512kB

CPU:

32 bit ARM RISK processor

Operating System:

Max ID Sapphire Rapid Application Development Environment

Peripherals

Barcode Reader: 1D / 2D barcodes

User Interface:

Display: Graphic LCD with back light & grey scale

Communications:

USB: USB 1.1/2.0 full speed

WLAN: Standard IEEE 802.11b/g Wi-Fi
WEP, WPA/WPA2 (PSK & Enterprise)

Regulatory:

ICASA: TA-2009/1314-SABS CISPR22
(Radiated & conducted emissions)

Health & Safety: (IEC60950-1:2002 SANS 60950-1:2003)
WCT 09/1136
IEC61000-4-2, IEC61000-4-3

Power:

Battery: Replaceable 3.7V Lithium Polymer

Environment:

Operating Temperature: 0° C to 40° C

Humidity: 5% to 90% non-condensing

Power Supply: 240V A.C. to 5V D.C. USB charger

10.12 GATE MOTOR

10.12.1 The main entrances of certain sites shall be equipped with motorized sliding gates and electric gate motors in line with CP_TSSPEC_213

10.12.2 These installations shall include IR detectors, motor pad lockable anti-theft bracket and civil works such as kerbing, paving, trenching, backfill, compaction and sleeve installations (Class 6 HDPE) for full system operation.

~~10.12.3 The motorized sliding gates shall form part access control systems and the complete ISS system.~~

10.12.4 The electrical gate motor shall be in accordance with the following minimum requirements:

Input Voltage:	220V – 240V ± 10%, 50Hz
Motor Voltage:	24V DC
Motor Power Supply:	Battery Driven (standard capacity = 2 x 7Ah)
Battery Charger:	2A @ 27.5V
Current (mains):	170mA
Current (motor at rated load):	8A
Operator push force Starting:	20kg
Operator push forced Rated:	15kg
Maximum gate length:	50m
Maximum gate speed:	40-50m/min
Manual override:	Lockable lever with key release
Maximum number of operations per day:	750
Duty cycle:	25%
	Operations in standby with 2 x 7Ah batteries
Half day:	58
Full day:	37
Collision sensing:	Electronic

Operating temperature range:

-15°C to + 50°C

Integration:

Controlled with access control system

10.13 MAIN GATE ENTRANCE TURNSTILE

10.13.1 Turnstiles shall be used to manage pedestrians' access.

10.13.2 The turnstiles shall be linked to, and controlled by the access control system.

10.13.3 Installation of the turnstiles shall include all civil work, a shelter and screed floor, and linking to the access control system for full operation.

10.13.4 The turnstile shall further be equipped with a pad-lock facility with anti-bolt cutting measures.

10.13.5 All turnstiles shall be provided with a concrete base floor and sheet-metal shelter of min. 3 x 3m.

10.13.6 The depot site main gate entrance full height, bi-directional turnstile shall be in accordance with the following minimum requirements:

Direction:	Bi-directional
Paintwork:	Powder coated – Blue
Power:	220 Volt AC
Frequency:	50Hz
Power Consumption:	50W (single turnstile)
Dimensions:	Single turnstile: 1430mm x 2250mm
Rotor Diameter:	1200mm
Rotor Arm Configuration:	3 arm (120°)
Rotor Arms:	32mm diameter U-tube arms spaced 165mm apart
Weight:	Single turnstile (4 arm) 160kg
Systems Integration:	Shall integrate with access control systems Unlocking for entry/exit rotation controlled through normally open dry contact Transaction / Rotation complete output Integral wire ways with draw wires in place – no exposed wires

10.14 BUILDING'S MAIN ENTRANCE TURNSTILE

10.14.1 The depot's with access control systems shall be equipped with turnstiles at the main entrance or reception areas as to National key point Act.

10.14.2 The turnstile shall be wide enough for a wheelchair to pass through and linked to the access control system.

10.14.3 The depot main building entrance or reception area bi-directional turnstile shall be in accordance with the following minimum requirements:

Power:	220 Volt AC
Frequency:	50Hz
Power Consumption:	300W per lane
Power Failure Operation:	The glass wings can be easily moved into the cabinet to allow free access
Fire Alarm Operation:	Trigger can activate barriers to remain in the open position for free access
Systems Integration:	Integrates with all access control and time & attendance systems

Operating Cycle Time:	Open/Close 1 second
Tamper Alarm:	Electronic output for a building security alert, e.g. lock doors or activate CCTV LED lights show red cross Internal buzzer sounds
Standard Operational Modes:	Entry and exit Entry only Exit only Optical mode for entry and exit
Wheelchair:	Wheelchair friendly

10.15 DEPOT MAIN GATE VEHICLE BOOM

10.15.1 Where required the main entrance gate to depot site shall restrict access by means of a boom gate. Such boom gate installation shall be linked to the access control system for operational control. The installation shall be complete with all required loop detectors, card reader pedestals, camera pedestals and civil works such as curbing, paving, trenching, backfill, compaction and sleeve installations (Class 6 HDPE) for full system operation.

10.15.2 The boom gate shall be in accordance with the following minimum requirements:

Input Voltage:	240V AC ± 10%, 50Hz		
Motor Voltage:	12V DC		
Motor Power Supply:	Battery-driven (standard capacity – 7Ah)		
Battery Charger:	1.8A @13.8V		
Current Consumption (mains):	170mA		
Boom pole length:	3.0m	4.5m	6.0m
Boom pole raise time (adjustable):	1.2sec	3sec	3sec
Duty cycle – mains present:	Maximum number of operations per day 3000 80%		
Half day:	Operations in standby with 7 Ah battery 3000		
Full day:	3000		
Collision sensing:	Electronic		
Operating temperature range:	-15°C to +65°C		
Traffic Barrier Pedestrian fence on boom:	Yes		

10.16 VEHICLE GOOSENECK

10.16.1 A double height Gooseneck of in 75mm heavy wall, mild steel square tubing shall be manufactured and installed.

10.16.2 The base plate shall be of 230mm x 230mm x 10mm welded to the square tubing.

10.16.3 Two heads with rain shields are required with a 500mm offset from the vertical.

10.16.4 These headsshall be at 800mm for cars and 1700mm for trucks.

10.16.5 Each head shall be of 250mm (Width) x 290mm (Height) x 125mm (Top Depth) x 50mm (BottomDepth).

10.16.6 A removable Stainless Steel faceplate shall be mounted in the head for equipment mounting.

10.16.7 The gooseneck shall be power coated in white or light grey.

10.16.8 All cables shall be routed within the gooseneck and exit out the bottom of the baseplate.

10.16.9 Balustrades shall be positioned in front of the gooseneck to prevent damage by vehicles.

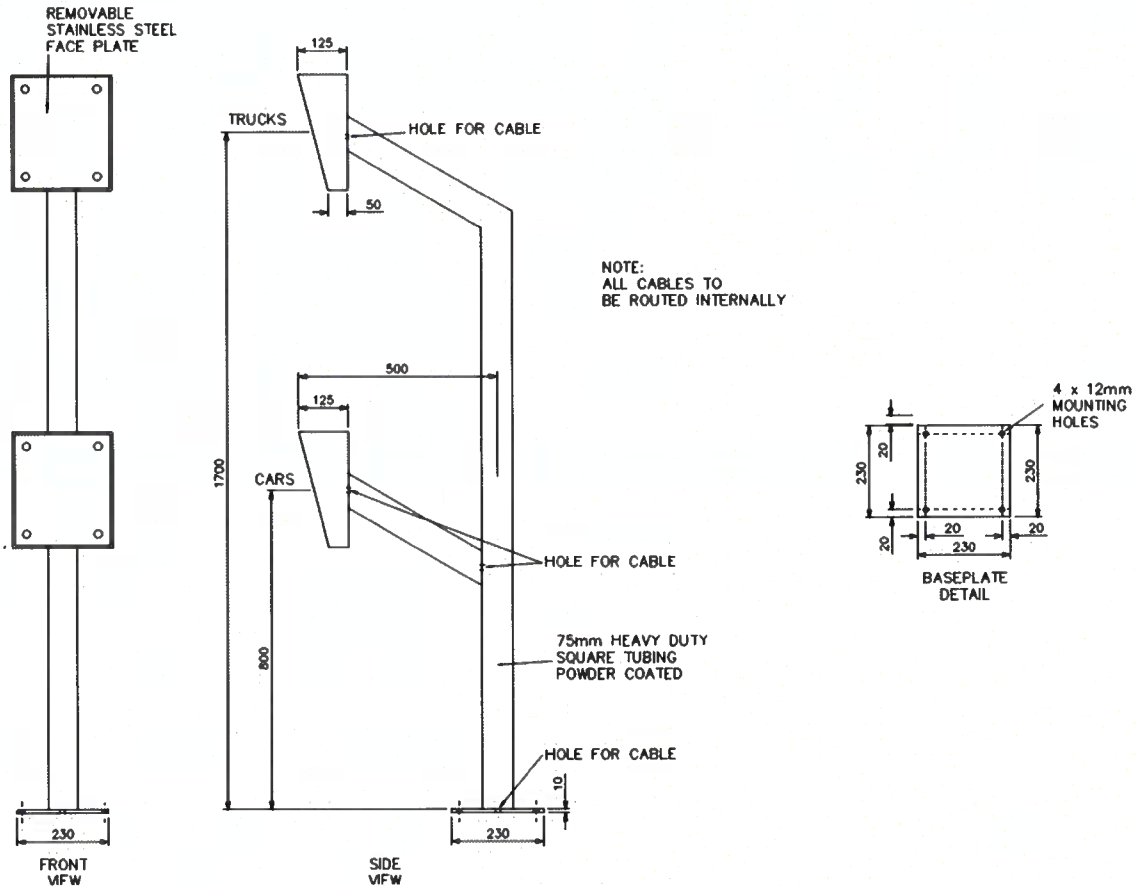

Figure 12: Vehicle Gooseneck

11. CCTV

The CCTV and its installation shall be in accordance with City Power's CP_TSSPEC_294 specification.

11.1 GENERAL REQUIREMENTS

- 11.1.1 The CCTV system and its installation shall consist of IP cameras, digital video recorders, camera power supplies, Ethernet cables (PoE), and mounting racks as detailed below.
- 11.1.2 The mounted cameras shall be powered over Ethernet (POE) and be capable of IP based communication or Ethernet communication.
- 11.1.3 Cameras shall be securely fixed to buildings structures using small expanding type bolts. Where pole mounted cameras are installed on poles in outdoor applications cross- arm Mounting shall be used.
- 11.1.4 The cross-arm shall have a steel strap, which bolts to a U-bracket with a minimum of 2 M10 bolts, washers and nuts around the top of the pole.
- 11.1.5 Brackets for cameras shall consists of a wall or arm bracket that is manufactured from sturdy cast aluminum and shall include internal cable wire management.
- 11.1.6 Brackets that are suitable for rugged environments, shall be supplied and installed with cameras to suite pole-, corner-, or roof mounting when required.
- 11.1.7 Brackets shall further be powder coated and shall be fixed with stainless steel bolts and

SPECIFICATION FOR INTERGRATED SECURITY SYSTEMS

REFERENCE

REV

CP_TSSPEC_237

1

PAGE

49

172

nuts insteel cross arms or with electro galvanized expanding fixings in to brick or concrete.

- 11.1.8 Specialized stainless steel camera brackets shall be used for external PTZ cameras mounted onto buildings. These brackets shall extend the camera by 1m from the building to give unrestricted 360° viewing. These specialized brackets are adjustable and can swing to the sides for easy maintenance.
- 11.1.9 Camera domes shall be stand-of bracket mounted in buildings and on steel cross-arm brackets when pole mounted. Fiber-optic cable shall be used to connect to outdoor, pole mounted units. The OFC shall be installed in conduit to the outside of the building and then via manholes and 50mm Ø uPVC sleeves in ground to a distribution box at the pole where the cameras are required. The OFC shall have fiber to copper converters at both end of the OFC run.
- 11.1.10 Ethernet cable to outdoor cameras on or in buildings shall be installed in 20mm or 25mm Ø electro galvanized conduits and draw boxes internally to buildings from the POE switch enclosure to an outlet box on the inside of the building.
- 11.1.11 Where there is no direct access to the cable management bracket the Ethernet cable shall be installed in flexible spiral steel tubing to the camera.
- 11.1.12 All cameras selected shall have full integration into the existing Network Video Recording system.
- 11.1.13 The following cameras shall be used as standard,
 - 11.1.13.1 Perimeter cameras
 - 11.1.13.2 Door / gooseneck cameras
 - 11.1.13.3 Vehicle license cameras
 - 11.1.13.4 Passage / office cameras (Dome housing)
 - 11.1.13.5 PTZ cameras
 - 11.1.13.6 Special Temperature sensing cameras

11.1.14 The above cameras shall comply with the minimum requirements as detailed in the paragraphs to follow.

11.2 PERIMETER CAMERA

11.2.1 The perimeter cameras shall conform to the following minimum requirements:

Type:	Outdoor Fixed Network Camera
Lens - Standard:	F1.3, IR corrected, Megapixel resolution, P-Iris
Lens - Telephoto:	12.5-50 mm Telephoto Lens, P-Iris, F1.4
Resolution:	1080p 25/30 fps (WDR): 1920x1080 to 160x90 Lightfinder and WDR
Light Sensitivity:	Color: 0.18 lux, B/W: 0.04 lux, F1.3 HDTV 1080p 50/60 fps: Color 0.36 lux, B/W: 0.08 lux, F1.3
Operating temperature:	-40 °C to 50 °C
Casing:	IP66 rated
Analytics:	Cross Line Detection (tripwire), Video Motion Detection

11.3 DOOR (GOOSENECK & GENERAL OVERVIEW) CAMERA

11.3.1 The door cameras shall conform to the following minimum requirements:

Type: Outdoor Fixed Network Camera with IR illumination
Lens: Fixed iris, Megapixel resolution, IR corrected 2.8 mm, F2.0
Light Sensitivity: Color: 0.8-100000 lux, F2.0, B/W: 0.16 lux, F2.0, 0 lux with IR illumination on
Resolution: 720p 25 fps
Operating temperature: -30 °C to 50 °C
Casing: IP66 rated
Analytics: Video Motion Detection

11.4 VEHICLE LICENSE CAMERA

11.4.1 The vehicle license cameras shall conform to the following minimum requirements:

Type: Outdoor Fixed Network Camera with IR illumination
Lens: Varifocal, 3.0–10.5 mm, F1.4
Light Sensitivity: Color: 0.25 lux, F1.4 B/W: 0.05 lux, F1.4, 0 lux with IR illumination on.
Resolution: 720p 25 fps
Operating temperature: -30 °C to 50 °C
Casing: IP66 rated
Analytics: Video Motion Detection

11.5 DOME CAMERA

11.5.1 The dome cameras shall conform to the following minimum requirements:

Type: Fixed Dome Network Camera
Lens: F2.8, Fixed iris, Megapixel resolution 2.8 mm
Light Sensitivity: 1.5-100000 lux, F2.8
Resolution: 1280x800 to 320x240 25fps
Operating temperature: 0 °C to 45 °C
Housing: IP42 rated
Analytics: Video Motion Detection

11.6 DOME CAMERA LONG RANGE

11.6.1 The dome cameras shall conform to the following minimum requirements:

Type: Fixed Dome Network Camera
Lens: Varifocal, 3.0-10.5 mm, F1.4
Light Sensitivity: Color: 0.25 lux, F1.4 B/W: 0.05 lux, F1.4
Resolution: 1920x1080 to 160x90 25fps
Operating temperature: 0 °C to 50 °C
Housing: IP42 rated

Analytics: Video Motion Detection

11.7 PTZ CAMERA

11.7.1 The PTZ cameras shall conform to the following minimum requirements:

Type: PTZ Dome Network Camera
Lens: f=4.3-129 mm, F1.6-4.7, Autofocus, Autoliris, 58.3° - 2.1° view
Light Sensitivity: Color: 0.15 lux at 30 IRE F1.6 B/W: 0.008 lux at 30 IRE F1.6
Resolution: 280x720 (720p) to 240x135, 25fps
Pan: 360° endless, 0.05-700°/s
Tilt: +20 to -90° with nadir flip, 0.05-500°/s
Zoom: 30x Optical, 12x Digital, Total 360x zoom
Operating temperature: -50°C to +50°C
Wide Dynamic Range (WDR): 130 dB
Casing: IP66 rated
Analytics: Video Motion Detection, Auto Tracking

11.8 TEMPERATURE ALARM CAMERA FOR CONDITION MONITORING

11.8.1 The temperature alarm cameras shall conform to the following minimum requirements:

Type: Temperature Alarm Camera
Camera Sensor: Sunsafe, Uncooled Micro bolometer amorphous silicon
Array Format: 640 x 480 or 384 x 288 pixels
Spectral Response: 7.5 to 13.5 µm LWIR
Temporal NETD: 50 mK at f/1.0
Temperature Range: -40 °C to 50 °C
Power Supply: 24VDC
Housing: IP66 rated

Note: Temperature alarm cameras to run on separate stand-alone system.

11.9 CAMERA POWER SUPPLIES

11.9.1 Where cameras cannot be directly powered from a POE switch, a POE injector shall be provided. The two types of injectors are listed below:

11.9.1.1 802.3af

Supply of 48VDC and up to 350mA so that the power initiated does not exceed 15.4W and the power that is delivered does not exceed 12.95W. It shall be supported on Category 6 cable.

11.9.1.2 802.3at

Supply of 50.0–57.0 VDC and up to 600mA so that the power initiated does not exceed 30W and the power that is delivered does not exceed 25.5. It shall be supported on Category 6 cable.

SPECIFICATION FOR INTERGRATED SECURITY SYSTEMS

REFERENCE

REV

CP_TSSPEC_237

1

PAGE

52

172

11.9.2 The POE injectors for dome cameras shall be housed in a solid plastic enclosure with a screw down lid and a neoprene seal in a groove between the lid and the box.

11.9.3 The box shall have knock-outs for 20mm Ø cable glands.

11.9.4 A separate power supply shall be used for each camera.

11.9.5 The power supply shall comply with the following specifications:

Enclosure rating: IP66
Operating temperature: -40 °C – +40 °C

11.9.6 Power supplies shall be mounted in the power distribution box at the pole where cameras are mounted.

11.10 VIDEO RECORDERS

11.10.1 The video recorder required in this contract shall be of the 19" rack mount type and shall have an IP recording rate of 240Mbps or better.

11.10.2 The recorder shall operate with the latest Windows operating system, 64bit operating system and the necessary software to communicate with the existing City Power recording platform used for video streaming.

11.10.3 Recorders shall be supplied with power from the UPS cabinet specified further herein.

11.10.4 The recorder shall further have and comply with the following features and specifications:

IP Recording Rate: 240Mbps
Channel Count: 60
Analogue Encoding: Up to 32 encoder channels
Storage Options: 24TB
Chassis Type: 3U 19-inch rack-mount chassis
CPU: Xeon E3-1275v2 3.5GHz Quad Core
Operating System: Latest Windows Professional 64-bit
RAM: 8GB DDR3 (4 x 2GB) 1600MHz
On-board NICs: Dual 10/100/1000 Ethernet ports
Optical Drive: CD/RW-DVD/RW
Operating System Drive(s): 1 x 250GB internal SATA hard drive
RAID Controller: Adaptec 8805 RAID controller
Video Storage: Up to 8 SATA 7200 RPM hard drives
Serial Port: 2 x serial ports
USB Ports: 4 x USB 2.0
Video Output: 1 x VGA, 1 x DVI-D
Power Supply: Dual 420W, 8-5A redundant power supplies
Rail Kit: Rack-mount rail kit
Operating Temperature: 5°C to 40°C
Regulatory Compliance: CE, FCC (Class A), UL 60950, ROHS

11.10.5 The recorders shall be suitable to operate with cameras of various makes which can communicate via Ethernet with the recorder.

11.10.6 All cameras shall be recorded and viewed in the H.264 compression standard

52

11.10.7 Cameras shall only record on an event (motion, cross line detection, access control event, alarm

event, etc.), there should be a 5 second pre and post event recording period.

11.10.8 Cameras shall be configured for recording at 12 images/s (ips)

11.11 VIDEO VIEWING STATION

11.11.1 A specialized rack mounted 21" video monitor shall be supplied together with the video recorder on each site where CCTV is required.

11.11.2 The monitor shall be used for setup of cameras (OSD) and for viewing pre-recorded video data on the video recorder.

11.11.3 The monitor shall be powered from the UPS cabinet specified in this document.

11.12 INFRARED ILLUMINATORS

11.12.1 Infrared illuminators are required to be installed together with perimeter cameras to enable long distance night viewing and recording of video.

11.12.2 The illuminator shall be of the high performance, long life and zero maintenance type and shall employ surface mount IR LED's and shall deliver clear infrared light for clear night time video pictures and shall have a working life of 10 years.

11.12.3 The unit shall provide illumination in low light conditions for up to 370m (in narrow angle setting) from and up to 100m (in wide angle setting- 180°).

11.12.4 The unit shall be supplied complete with a bracket and its own power supply.

11.12.5 The unit shall be vandal resistant and shall have a polycarbonate lens.

~~11.12.6 The unit shall consist of three modules so that adjustment can be made for any angle between 10° and 180° projection~~

11.12.7 The illuminator shall further comply with the following features and specifications:

Optics:	SMT LED's
Power Consumption:	120W max
Power supply input:	230VAC
Voltage output:	13.5V current controlled
Temp Range:	-50 to +50°C
Color:	Black
Wavelength:	850 or 940nm (depending on camera selected)
Photocell:	Adjustable

11.12.8 Where illuminators are mounted on poles together with cameras for outdoor substation illumination, the bracket of the unit shall be fixed to a pole mounted mounting arm.

11.12.9 The mounting of the illuminator shall not hinder the mounting and adjustment of cameras. The positions of IR illuminators are shown on the layout drawings accompanying this specification.

11.13 CAMERA POLES AND POWER BOXES

11.13.1 **POWER BOXES**

**SPECIFICATION FOR INTERGRATED
SECURITY SYSTEMS**

REFERENCE

REV

CP_TSSPEC_237

1

PAGE

54

172

-
- 11.13.1.1 Power boxes are required at each pole to house 230V distribution circuit breakers, 230VAC/DC power supplies, and fiber to copper media, Ethernet switches, fiber termination boxes and 230V, 3 x 16A plug sockets for distribution. Power boxes are specified further herein.
- 11.13.1.2 The power boxes or cubicle required in this Contract shall be manufactured from 2mm 2CR12 steel and shall be powder coated Med Sea Grey inside and outside.
- 11.13.1.3 The box dimension shall be 800mm wide (clear opening) x 400mm deep x 1200mm high (clear opening)
- 11.13.1.4 The door of the box shall have folded edges which shall close inside the box casing against a lip. The door edge shall have a neoprene seal all around the door edge which can seal against the lip in the cubicle. The door shall have at least 4 heavy duty stainless steel hinges and a stainless steel swing handle that is pad-lockable.
- 11.13.1.5 The box shall be mounted on the concrete pole" using 2 x M12 hot dip galvanized bolts with pole washers cast into the concrete pole forfixing the cross-arms at the top of the box and at the bottom of the box as in attached drawings.
- 11.13.1.6 The bolt heads shall be welded to the pole washers before being galvanized and cast into the pole.
- 11.13.1.7 The Contractor shall do the design of the box to determine the cross-arm positions and spacing thereof on the box and shall provide this dimension to the pole manufacturer. The box position shall be placed at a suitable height above the access opening of the pole
- 11.13.1.8 Bolting shall be done as shown in Figure 13: Power Box Fixing to provide a tamper proof method of fixing. No cutting of the steel work shall be done after galvanizing. The threads of the bolting holes in the strap assembly can be cleaned with a tap after galvanizing, if necessary.
- ~~11.13.1.9 The box shall further have a box type cover mounted below the box and fixed from inside the box with stainless steel bolts into welded nuts on the top flanges of the cover.~~
- 11.13.1.10 The cover shall be of the same material and finish as the box.
- 11.13.1.11 The cover shall be of suitable dimensions to cover the access hole in the pole to enable cables in the pole to be routed into the box.
- 11.13.1.12 The cover shall have a solid bottom, sides and front and shall have flanges on the inside at the top for bolting from inside the power box.
- 11.13.1.13 The cover shall protect the cables entering the box from the access hole in the pole.
- 11.13.1.14 The box shall thus be mounted above the access hole in the pole so that the cover below the box covers the access opening in the pole.
- 11.13.1.15 The box shall have a removable bolted back plate in the back of the box for the mounting of all the equipment in the box.
- 11.13.1.16 The box shall further have a DIN rail inside at the top of the box for the mounting of circuit breakers.
- 11.13.1.17 A row of at least 6, 16A three pin industrial surface mounted plugs shall be mounted below the circuit breakers, with sufficient space left between the circuit breakers and the plugs for a PVC finger trunking for housing the wiring between the circuit breakers and the plugs.

**SPECIFICATION FOR INTERGRATED
SECURITY SYSTEMS**

REFERENCE

REV

CP_TSSPEC_237

1

PAGE

55

172

-
- 11.13.1.18 A brass earth bar and brass neutral bar with at least 10 wiring holes with screw fixing for earth wires and neutral wires shall be mounted in line with the DIN rail and to one side thereof for the termination of earth and neutral wiring. The neutral bar shall be mounted on stand-off insulated posts.
- 11.13.1.19 The DIN rail shall be equipped with a double pole 30A main incoming isolator and 6 x 6A circuit breakers for supply to the plugs. The fault rating of the isolator and circuit breakers shall be 5kA and all the isolator and circuit breakers shall be fitted with shrouds.
- 11.13.1.20 The box shall further have two 50mmx 50mm PVC finger trunking runs vertically and full length down the middle of the box.
- 11.13.1.21 The bottom of the box shall consist of a removable 3mm, 316 stainless steel gland plate which shall seal on a neoprene seal all-round the plate edges. The gland plate shall be of sufficient size to allow the entry of power cable and fiber optic cable and shall allow for the Ethernet and DC power cables to the cameras and PIR illuminator at the top of the pole. All cable shall be installed internally to the pole in the core thereof.
- 11.13.1.22 The gland plate shall have an M6 brass earth stud through the plates with two brass nuts on both sides of the gland plate for the external and internal connection of earth wires.
- 11.13.1.23 The external earth wire shall be of 7-core copper clad steel wire type. The copper cladding shall be metallurgical bonded to the steel wires. The earth wire rating shall be suitable to withstand a 5kA earth fault current for 1 second.
- 11.13.1.24 This earth wire shall be connected to the stainless steel earth terminal on the pole below ground level and from there to the bottom of the earth stud specified earlier herein.
- 11.13.1.25 The earth wire from the earth stud on each box shall be installed together with the power supply cable to the power box and shall be connected to the main earthing system in the 400/230V distribution board in the building or substation of the site.
- 11.13.1.26 All the internal earth of the power box shall be connected to the earth stud above the gland plate.
- 11.13.1.27 The camera and PIR illuminator earth connections of equipment mounted at top of the pole shall be connected to the stainless steel earth terminal at the top of the pole.

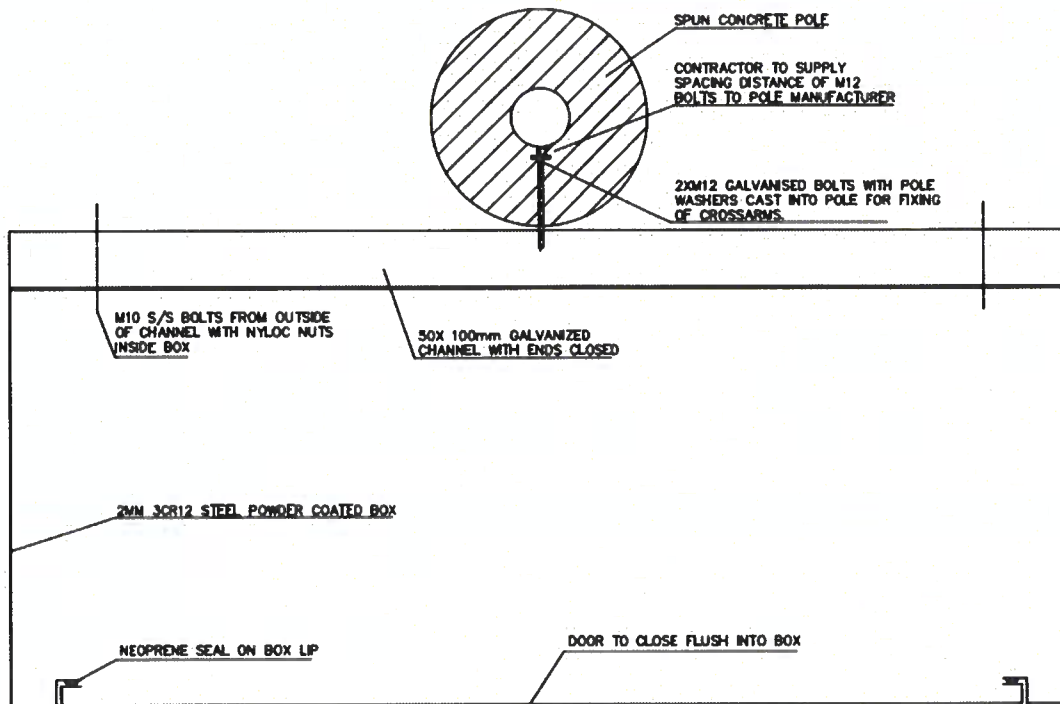

Figure 13: Power Box Fixing

- 11.13.1.28 All earth connections ends be done with crimped lugs and bolting shall be done on earth terminal or studs with brass or stainless steel nuts and lock washers.
- 11.13.1.29 Earth wire shall not be exposed anywhere in the installation on the outside of buildings.
- 11.13.1.30 The box shall further have a cylindrical type lock and 2 keys per lock.
- 11.13.1.31 The final dimensions of the box shall be determined by the Contractor to house the equipment offered.
- 11.13.1.32 The Contractor shall submit works drawings of the box and the brackets to the Engineer for approval before the boxes are manufactured.

11.13.2 CAMERA POLES

- 11.13.2.1 Concrete poles shall be of the spun type with hollow cores for the installation of cable.
- 11.13.2.2 Poles shall be calculated to be 1m above the wall/fence where it is mounted. The pole shall be planted at a depth of 1,2m using a mixture of sifted soil and cement. Pole dimensions shall be 220mm Ø at the bottom of the pole and 130mmØ at the top of the pole.
- 11.13.2.3 Poles shall have stainless steel earthing terminals near the top of the pole and below ground level for earth connections. A 76mmØ x 100mm long hot dip galvanized spigot shall be cast into the top of the pole for cross arm mounting for cameras and IR illuminators.
- 11.13.2.4 An access box shall be provided in the pole at 1700 mm from the bottom end of the pole and the cable entry opening into the core of the pole shall be at 700 mm from the bottom end of the pole.
- 11.13.2.5 The soil condition where poles are to be mounted shall be determined in conjunction with the Engineer and the Engineer shall instruct the Contractor as regards to the quantity of cement required for the footing of the pole. The backfilling and compaction around a pole

shall be done in moisture 150mm layers which shall be compacted to 90 MOD AASHTO, regardless of whether cement is used in the backfill.

- 11.13.2.6 Pole shall be transported and handled on site in accordance with the instructions of the manufacturers thereof. Damaged poles shall not be acceptable on sites. The manufacturer's instructions for the stacking of poles on site and the lifting equipment to be used on site shall be followed by the Contractor. Drawing shall be submitted by the Contractor for approval by the Engineer prior to commencing of manufacturing.
- 11.13.2.7 All concrete poles shall be equipped with a "three-point-star" or "crows-foot" earthing electrode configuration. Earthing electrodes shall be 16mm dia., 1.5m long copper clad steel rods. The concrete pole reinforcing steel shall be connected to all material casted into the concrete pole such as spigots, nuts, bolts and earthing ferrules.

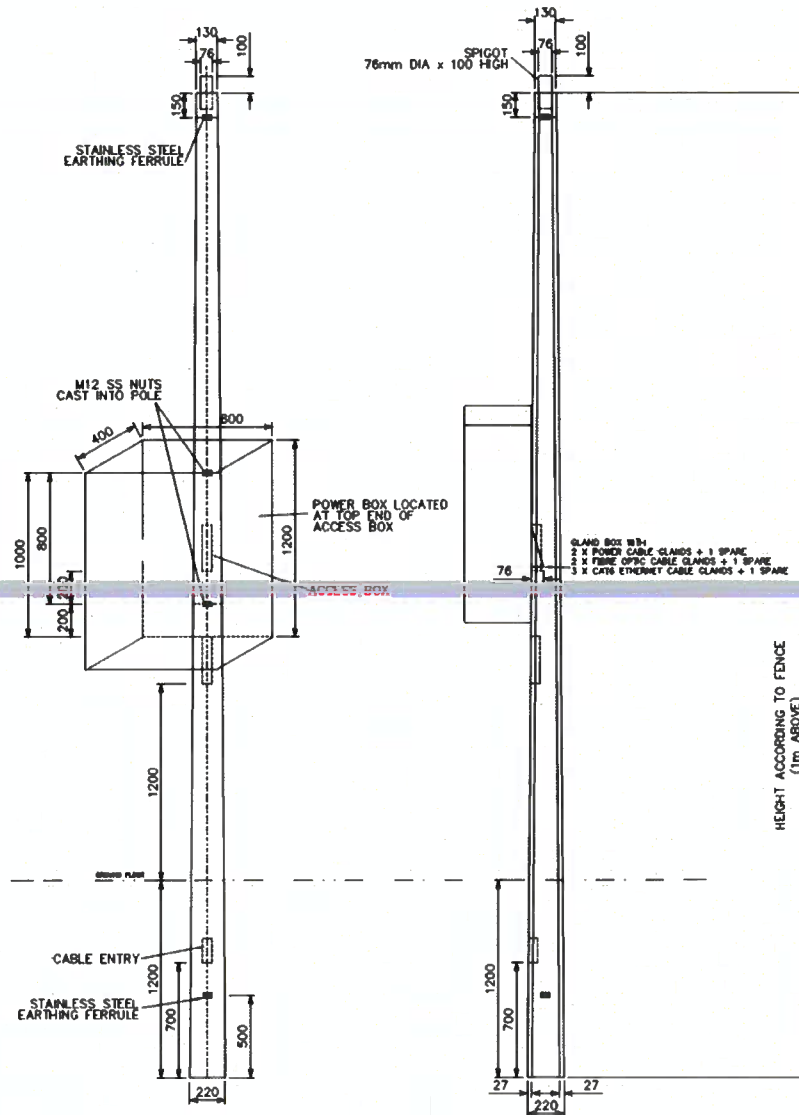

Figure 14: Perimeter Camera Pole

11.13.3 INTERFACE EQUIPMENT AND POWER SUPPLIES

- 11.13.3.1 The 230VAC to DC power supplies for the camera, Ethernet switch and PIR illuminator

shall be mounted on the back plate in the box. The Fiber to Ethernet converters shall be mounted close to the Ethernet switch. The Ethernet cable from the switch to the camera shall be routed through the gland plate of the box and via the access opening in the pole to camera at the top of the pole.

- 11.13.3.2 The Fiber to Copper Converter shall be SFP, LX 1310nm tough type. Where more than one camera is installed on a pole a switch shall be installed so that multiple cameras can be added to a pole. The CAT6 cables shall plug directly into the switch.
- 11.13.3.3 POE Injectors for cameras are specified in clause "17.9 Camera Power Supplies" herein and power supplies for PIR illuminators are specified in clause "17.12 Infrared Illuminators" herein.

12. FIRE DETECTION

12.1 GENERAL REQUIREMENTS

- 12.1.1 This section of the specifications includes the supply, installation, and connection of microprocessor controlled, addressable reporting fire alarm equipment required to form a complete coordinated system ready for operation. It shall include, but not be limited to, alarm initiating devices, alarm notification appliances, fire alarm control panel, auxiliary control devices, annunciators and wiring.
- 12.1.2 The Control panel shall be of the advanced two –loop type with high sensitivity smoke and fire sensing and the panel shall be able to identify and disregard conditions that would result in false or unwanted alarms, but to recognize real fires.
- 12.1.3 There shall be constant communication between control panel and the sensor and other devices on the loops and it shall be possible to monitor and control up to 127 devices connected to the panel.
- 12.1.4 Existing fire detection equipment shall be used as far as possible in line with CP_TSSTAN_059 and CP_TSSTAN_062
- 12.1.5 Where standard analogue equipment shall be replaced with addressable equipment. The Engineer shall be informed of such an existing installations and shall be approached for clear instructions regarding the incorporation or replacement of old equipment.

12.2 FIRE ALARM CONTROL PANEL

- 12.2.1 The control panel shall be able to function as a stand-alone unit, together with its own power supplies, and shall not be dependent on external control equipment, such as computers, for functioning. The control panel shall be of the wall-mounted type and shall comply with SANS50054-2 and SANS 10139.
- 12.2.2 The power supply shall be integral to the panel and shall comply with SANS50054-Part 4. The front panel of the control panel shall comprise a keyboard, alpha numeric display, text and indicator LEDs, etc. The occurrence and location of an event shall be displayed on the screen. The display shall be of the graphics LCD, alphanumeric, backlit type capable of displaying atleast 160 characters.
- 12.2.3 The panel shall also have the facility to communicate with the integrated control system through a TCP/IP network switch.
- 12.2.4 The panel shall be easy to operate using advanced sensing techniques, shall have extensive networking ability, and shall further have automatic self-test ability. 58
- 12.2.5 Sensing devices shall not switch into an alarm state. The control panel shall take all decisions. The

**SPECIFICATION FOR INTERGRATED
SECURITY SYSTEMS**

REFERENCE

REV

CP_TSSPEC_237

1

PAGE

59

172

panel shall further have automatic contamination adjustment for each sensor controlled from the panel.

- 12.2.6 Provision in the form of suitable terminals, connectors, or ports, shall be made on the control panel for the connection of peripheral equipment, such as computers, printers and interface equipment, to enable the accumulation of data generated by detectors and the control panel, to be used for future reference, or for the relaying thereof to remote monitor or control equipment.
- 12.2.7 Control panels shall be constructed for minimum power usage in both battery and mains power supply modes.
- 12.2.8 The power supply of the fire panel shall be a 230VAC/27,6VDC unit mounted in the fire detection panel. The housing shall be lockable and shall have a tamper switch output and a fault output that shall be wired to alarm inputs on the fire panel.
- 12.2.9 The power supply shall be of the switch mode type and shall be rated for a continuous output of 3A, shall be complete with 2 x 12V batteries of the sealed and maintenance free type, and shall have the capability to supply power to the fire panel whilst charging the batteries.
- 12.2.10 To simplify installation and connection of wires on site, terminals installation personnel shall clearly group and mark with a label strip for identification, all outgoing and incoming terminals.
- 12.2.11 All other equipment in the control panel shall be suitably labelled to simplify maintenance and installation, and all panel-mounted equipment shall likewise be labelled.
- 12.2.12 Outgoing and incoming power and field wiring shall be individually, and correspondingly, numbered at each point of termination.
- 12.2.13 The control panel shall have knock-outs in the bottom plate thereof to terminate conduits for all power cabling, and knock-outs in the top plate thereof to terminate conduits for signal and other electronic cabling/wiring. Holes drilled on site for this purpose shall not be acceptable.
- 12.2.14 Wiring for all sensors and equipment in the fire detection system shall be installed in 20 mm Ø electro galvanized conduit and draw boxes. Conduit runs shall be supported on galvanized spacer saddles at distances not exceeding 1.5 m.
- 12.2.15 All identification labels, as well as wire terminal numbers, shall be clearly shown on all wiring diagrams in the Maintenance Manual.
- 12.2.16 It shall be possible to silence the audible alarms without influencing the visual alarms.
- 12.2.17 The panel shall further comply with the following requirements:

EMC:	CE marked (2004/108/EC)
Loop capacity:	127 addresses
Compatibility:	All ZP analogue addressable equipment
Mounting:	Surface or recessed
<u>Power Requirements:</u>	
Panel type:	(Quiescent at 24 VDC) 2 loop 420mA
Panel alarm:	(Alarm at 24 VDC) 820mA 25% of zones in alarm
Monitoring:	Loop wiring Open and short circuit fault, earth leakage, sensor removed and wrong device type
Switched outputs (standard):	Sounder circuits (programmable) 2 x dual monitored Fire (common) 1 volt free N/O or N/C 1 volt free N/O or N/C Fault (common) 1 volt free N/O or N/C
Switched I/O:	Non loop devices, sounder circuits, relay
Software:	Firmware and site configuration programming - Flash

SPECIFICATION FOR INTERGRATED SECURITY SYSTEMS

REFERENCE

REV

CP_TSSPEC_237

1

PAGE

60

172

Standby batteries:	memory 2 x 12 volt sealed lead acid - up to 28 Ah Accommodated inside panel enclosure
Temperature range:	-5°C to +40°C
Humidity range:	10% to 90% RH (non-condensing)
Environmental:	IP30 (indoor installation)
Construction:	Enclosure - Back box and hinged door – sheet steel

- 12.2.18 The panel shall further have an on-board printer module together with a series of facility boardscan be added to the standard panel to extend any panel up to 768 programmable inputs and outputs.

NOTE: Where fire extinguishing is required by means of a gas discharge system a conventional fire alarm and extinguishing control panel is required. It shall be supplied with 3 fire zones that support up to 32 devices per zone. The zones shall be configurable for extinguishing in single zone or double zone configuration in any combination of zones. In addition the panel shall offer supervised outputs for first stage notification, second stage notification as well as optical warning indicators and actuator activation. Standard relay outputs are provided for EN54 compliance and system status notification, as well as multiple inputs for system control. This secondary gas discharge panel shall communicate via RS485 to the main Fire Control Panel.

- 12.2.19 The positions of fire detection panels are shown on the layout drawings accompanying this specification.

12.3 FIRE DETECTION SENSORS

- 12.3.1 The fire alarm system required in this contract shall make use of the following type of addressable sensors and equipment:

- 12.3.1.1 Addressable optical Smoke and thermal sensors
 - 12.3.1.2 Addressable manual call point - Red
 - 12.3.1.3 Addressable interface unit
 - 12.3.1.4 Addressable fire sounder with strobe light
 - 12.3.1.5 Addressable interface for conventional fire detectors
 - 12.3.1.6 Addressable high voltage line relay unit
- 12.3.2 The optical smoke and thermal sensors shall be mounted on a twist and lock-in type base. The base shall be ceiling mounted or on standard round electrical conduit boxes and shall have an indicating alarm red LED. When locked into the base it shall be possible to remove the sensorhead with a special tool.
- 12.3.3 Space shall be available on the base and the sensor head for a label with the address of the unit to identify the equipment so that a sensor can be re-installed in the correct base after removal.
- 12.3.4 The optical smoke and thermal sensors shall comply with the following requirements:

Specification: SANS 50050 - 5 (Class A1 and A2), SANS 50050 - 7 and CEA4021 60
Smoke element: SANS 50050 - 7 and CEA4021

Heat element:	SANS 50050 - 5 Class A1 and A2
Wiring:	2 core loop or spur, PH30 Fire resistant 2-core 1,5mm ² .
Area coverage:	Smoke element - 100m ² , subject to local codes.
Thermal element:	50m ² , subject to local codes
Monitoring:	Open and short circuit fault sensor removal and device type
Detection principle:	Smoke - photo electric light scatter, heat - thermistor
Addressing method:	7 way DIL switches in head
Operating voltage:	19.5 to 20.5 volts pulsed address line
Current:	600uA quiescent, 700uA alarm
Application:	Indoor installation
EN60529 rating:	IP32
Temperature range:	-10°C to +50°C
Humidity range:	20% to 95% RH (non-condensing) (95% RH in all tunnel installations)
EMC:	CE compliant
Material:	Molded ABS plastic

12.3.5 Sensors shall be installed at a suitable height above finished floor level to prevent tampering with the sensor.

12.3.6 The positions of fire sensors are shown on the layout drawings accompanying this specification.

12.4 FIRE BEAM DETECTORS

Supply Voltage:	24 VDC nominal
Imager Current Consumption:	Nominal (at 24 VDC): 8mA (1 Emitter), 10mA (7 Emitters), Peak (at 24 VDC) during training mode: 31mA
Emitter Current Consumption:	Wired Version (at 24 VDC): 350µA Std Power, 800µA High Power, Battery Version (1.0 — 3.2 VDC): OSE-RBA Built-in Battery: - SPVersion: 5-year battery life, -HP Version: 3-year battery life
Alarm Threshold Levels:	Low-highest sensitivity / earliest alarm: 20% (0.97 dB), Medium — medium sensitivity: 35% (1.87 dB), High — lowest sensitivity / maximum immunity to nuisance smoke conditions: 50% (3.01 dB)
Adjustment Angle:	±60° (horizontal), ±15° (vertical)
Configuration Options:	Imager: 45°, Field of View: Horizontal - 38°, Vertical - 19°, Detection Range: Standard Power: Min: 15m, Max: 60m, High Power: Min: 30m, Max: 120m/100m
Operating Conditions:	Temperature: -10°C to 55°C, Humidity: 10 to 95% RH (non-condensing)
Ordering Codes:	OSI-45 Imager - 38° coverage

12.5 MANUAL CALL POINTS

12.5.1 Manual call point units shall be addressable and shall comply with SANS 50050 - 11 and SANS10139, except that it shall be resettable with a key i.e. the front face of the unit shall not be a frangible element. The unit is operated either by pressing a resettable element.

12.5.2 Addressing shall be possible on the integral address card for interfacing with the fire detection system.

12.5.3 The unit shall be finished in powder coating and the word FIRE or a FIRE symbol shall be legible on the front face.

12.5.4 The call point shall be rated at IP24 in accordance with EN60529 and shall be constructed

of ABS plastic.

- 12.5.5 The wiring terminals of the unit shall be able to accept wiring lugs, and shall be of the screw and clamp plate type to hold a lug firmly pressed against its contact surface. Spring loaded push-in contacts shall not be acceptable.
- 12.5.6 The units shall be installed on surface in substations and in buildings.
- 12.5.7 Manual call points shall be installed at a height of 1200mm above finished floor level.
- 12.5.8 The positions of fire detection panels are shown on the layout drawings accompanying this specification.

12.6 SOUNDERS AND STROBES

- 12.6.1 Sounders shall be addressable and shall conform to SANS 50050 - 1 and SANS 50050 -4 and shall issue both audible and visual warnings from a single, addressable, loop wired unit.
- 12.6.2 The combined unit shall plug directly into a fixed base, which shall eliminate the need for any internal connections on the unit itself.
- 12.6.3 The unit shall have a high efficiency acoustic design and low current Light Emitting Diode (LED) visual element. The sounder and strobe color shall be red.
- 12.6.4 The unit shall have a unique self-test facility that activates automatically during routine sounder Testing.
- 12.6.5 The sounder shall have selectable continuous, intermittent and two-tone audible outputs to provide alert and evacuate and evacuation sounds.
- 12.6.6 Sound types shall be as follows:
 - 12.6.6.1 ~~Tone 1 - continuous 980 Hz~~
 - 12.6.6.2 Tone 2 - intermittent 980 Hz (0.5 secs on/off)
 - 12.6.6.3 Tone 3 - two tone warble 980 Hz/670 Hz
- 12.6.7 The sound level of unit for indoor use shall be 102 dBA measured at 1 m. and 112dBA for outdoor units. A volume control shall be included for indoor areas where a reduced sound output is required. Light output shall be equivalent to a 1J xenon element.
- 12.6.8 The EN60529 rating for an indoor unit shall be IP50.
- 12.6.9 The positions of sounders and strobes are shown on the layout drawings accompanying this specification.

12.7 GAS SUPPRESSION

- 12.7.1 The gas suppression system shall integrate and inter operate with City Power's existing fire detection system.
- 12.7.2 The detection system shall be designed and installed to conform to recognized international engineering standard such as SANS 10139 & ISO 369
- 12.7.3 The Gas that shall be used shall preferably be odorless and colorless and non-conductive
- 12.7.4 Audio and visual signals shall be used to alert City Power's personnel of the hazard

**SPECIFICATION FOR INTERGRATED
SECURITY SYSTEMS**

REFERENCE

REV

CP_TSSPEC_237

1

PAGE

63

172

-
- 12.7.5 To detect fire combustion at its true incipient stage, a detection system that detects the combustion particles that occur before smoke occurs shall be used to enable very early warning of fire, which means preventative action can be taken before any catastrophic event occurs.
- 12.7.6 Where no ceiling is present and the substation is covered by a sheet metal roof, the gas suppression system could be used inside the electrical cabinets in the room and all cable trenches.
- 12.7.7 In order to extinguish a fire as quickly as possible an automatic system that is non-toxic, internationally accepted by engineering standard shall be used without adversely affect the protected equipment and processes.
- 12.7.8 In the event of first detection of a fire and all air conditioning devices shall be tripped and all cable trenches be shall be properly sealed with a fire rated medium of at least one-hour or as per local standards and regulations.
- 12.7.9 All detection, alarm and extinguishing circuits shall be monitored for fire and fault. The substation fire protection system should operate a local audible and visual alarm system, and send an alarm to the control center.
- 12.7.10 The substation fire protection systems shall report to a central 24-hour manned operations security room, and wherever possible, a local fire brigade.

12.8 TESTS AND APPROVAL

- 12.8.1 The testing of the system shall be done in the presence and to the satisfaction of the Engineer.
- 12.8.2 Tests shall include simulation of fire conditions in each zone to prove the efficiency of all aspects of the system to the satisfaction of the Engineer.
- 12.8.3 All equipment, material, etc., which shall be necessary for these tests shall be supplied by the Contractor, including a suitable smoke generator.
- 12.8.4 The Contractor shall do his own complete commissioning tests before the actual first take-over tests are done. This is to satisfy himself that everything is working and is in accordance with the specification.
- 12.8.5 The Contractor shall arrange for the testing of the fire alarm installation by a third party inspection bureau. (FSB).
- 12.8.6 For any gaseous extinguishing system, a mandatory annual room integrity test shall be carried out as per SANS 369
- 12.8.7 The Contractor shall price for the testing and approvals in the Bills of Quantities.

13. INTRUSION DETECTION SYSTEM

13.1 GENERAL REQUIREMENTS

- 13.1.1 The intrusion detection system required in this contract shall consist of zone input cards, a command terminal (one on each site), surface mounted roller shutter magnetic contacts, PIR infrared motions sensors, electro- magnetic door locks, small magnetic contacts for light duty doors and beam sensors in pairs. The latter shall only be required if so listed in the Bills of Quantities.
- 13.1.2 The systems shall be linked to City Power's integrated Security system, as well as the third

parties armed response Control room.

- 13.1.3 On detection of an intruder, the system shall send alarms to both City Power and the armed response service provider's -control room.
- 13.1.4 The input control module cards shall be installed in the same enclosures as the Door ReaderController wherever possible.
- 13.1.5 Subsequent to the alarm notification, pepper gas and fog shall be used to deter intruders from the affected area in line with the intruder specification CP_TSSPEC_316.

13.2 DIGITAL INPUT CONTROL MODULES

- 13.2.1 The Input Control Modules (ICM) in this project shall be of the high speed series 2 type for acknowledgement and monitoring of critical alarm points in the intrusion detection systems of the substations and depots in the project.
- 13.2.2 The ICM shall be suitable for a 24VDC regulated power supply and shall comply with UL294 and shall be 1076 listed and CE marked.
- 13.2.3 The typical inputs which shall be monitored and/or controlled are:
 - 13.2.3.1 PIR intrusion detector signals
 - 13.2.3.2 Tamper switch contacts of electro-magnetic locks
 - 13.2.3.3 Door Monitor inputs
 - 13.2.3.4 Fire alarms, etc.
- 13.2.4 Input contacts on modules shall be programmed to generate an audible alarm and a flashing red LED at the specific emergency escape door when the door is jammed open or held open for a period which exceeds a predetermined period of time. This function shall be provided at each specific door which is required to close after the Rex Button or emergency escape button is activated to allow exit through the door. The audible alarms shall be in the form of a surfacemounted horn and flashing LED lamp combination next to the particular door. The tamper switch contact of an electro-magnetic lock shall likewise be wired into the ICM to generate an alarm if the magnet is jammed open or where tampering of the wiring has taken place.
- 13.2.5 The ICM units shall be of the modular PC board type shall contain input and output terminals, 2 form-C relays, discreet components, a processor and communication ports.
- 13.2.6 The ICM shall thus have:
 - 13.2.6.1 16 software configurable alarm inputs(1KΩ resistors for line suppression)
 - 13.2.6.2 2 non-supervised alarm inputs
 - 13.2.6.3 2 alarm (form-C, 5A) output relays
 - 13.2.6.4 1 RS485 interface (contacts for 2 wire or 4-wire connection)
 - 13.2.6.5 One power input (24VDC)
 - 13.2.6.6 8 DIP switches for addressing
 - 13.2.6.7 2 status LED's
- 13.2.7 The card shall be wired into the multi-drop RS485 daisy-chain of communication wiring of 64 a site and shall communicate directly with the System Interface Controller (SIC) or the Dual

Reader Controller (DRC), whichever is in use as system controller on a site.

- 13.2.8 The card shall be suitable to be mounted in a steel enclosure together with other control cards such as the DRC module cards. Mounting shall be with stand-off insulated posts.
- 13.2.9 The PIR's in an area such as an MV switchgear room shall be connected to the inputs on the card and the inputs shall be programmed to inhibit PIR's when the area is entered using an access card to prevent false alarms. The PIR's shall be automatically enabled in such an area when a signal is received from the control system indicating the exit of the area or the locking thereof by the access controls.

Primary Power (DC): The ICM is for use in low voltage, power-limited, class 2 circuits only

DC Input: 24VDC \pm 15%. 350 mA

Environmental

Temperature:
Operating: 0° to +70°C
Storage: -55° to +85°C

Humidity: 0 to 95% RHNC

Approvals: UL 294 and 1076-listed, CE-marked, ROHS compliant

13.3 ALARM KEYPADS

- 13.3.1 Alarm keypads with LCD displays terminals shall be provided and installed as shall be required in this contract to serve as a command reader from which user commands can be issued to execute local I/O functions.
- 13.3.2 The terminal shall be in the form of a durable encased unit and shall be mounted outside the door of the control room of the site.
- 13.3.3 The LCD display on the unit shall be of the 32 character backlit type and the keypad of the unit shall be a 16 position keypad containing figures 1 to 9 and 0, 4 function keys and a return and CMD key.
- 13.3.4 The display and keypad unit shall be supplied with 24VDC power from a dedicated 230VAC/24VDC power supply or from the nearest 24VDC power supply on site.
- 13.3.5 The interface with the System Interface Card (SIC) shall be via it's direct, multi-drop 2-wire RS485 or through a DRC port. The terminal shall normally be used as stand-alone RS-485 device in this project. In this mode it shall be possible to connect an optional card reader with Data1/Data0 or clock/data output to provide Card only, Card or PIN or Card and PIN capability.
- 13.3.6 The terminal shall support all "approved for use" reader technologies that communicate using Data1/Data0 or clock/data communication.
- 13.3.7 The terminal shall provide command status and other text feedback during reader operations
- 13.3.8 The terminal shall have arm-, disarm-, bypass- and force alarm mask groups.

Primary Power:

Voltage: 24 VDC \pm 15%

Current: 175 mA terminal only

Reader:

Power:	Pass-through (non-regulated)
LED Control:	2-wire or 1-wire bicolor LED
Buzzer Control:	Available with 1-wire LED control
Interface:	2-wire RS-485, or Wiegand
Environmental:	
Operating Temperature:	0°C to 50°C
Storage Temperature:	-20°C to 70°C
Humidity:	0% to 95% RHNC
Physical:	
Color:	White
Technology:	Communication RS-485: up to 1219m max, 24 AWG, 100ohm impedance Wiegand: up to 152m max, 18 AWG stranded wire
Approvals:	FCC approved, UL-listed, CE-marked

13.4 SURFACE MOUNTED ROLLER SHUTTER MAGNETIC CONTACTS

13.4.1 The unit shall be suitable to be mounted overhead or at floor level as the need shall arise on site and shall be of the industrial heavy duty type.

13.4.2 The unit shall consist of a two part, door mounted magnet and a door frame mounted housing, containing the switch and the wiring connection.

13.4.3 Both these parts shall be of heavy cast aluminum and the switch shall be of the reed type encased in an exclusive polyurethane potting material to prevent damage due to moisture or humidity.

13.4.4 The switch shall be of the normally open type and shall switch from NO to NC when the door or shutter is closed.

13.4.5 The contacts of the switch shall operate when the gap between the magnet and the switch assembly exceeds 75mm. Positioning on site shall be done to attain this requirement.

13.4.6 The two assemblies shall be fixed to the shutter and the frame with heavy duty tamper free stainless steel screws. Screws shall preferably be fixed into the steel frame and shutter by means of tapped holes.

13.4.7 The unit shall have a 4 wire tail for connection and the wiring of the tail shall be in stainless steel armoring for connection to the nearest draw box. These connections shall be as short as possible.

13.4.8 Refer to clause "**Error! Reference source not found. Error! Reference source not found.**"

13.4.9 for installation of wiring and cables in conduit systems.

13.5 PASSIVE INFRARED MOTION SENSORS

13.5.1 Passive infrared motion (PIR) sensors are required in this contract for the monitoring of intrusion into protected and secured areas when such areas are locked or where permanent occupation does not take place.

13.5.2 The sensors shall be of the volumetric type i.e. the PIR shall have a 360° coverage. The PIR shall thus cover a diameter of 9,3m when mounted at a height of 3m.

13.5.3 The unit shall have a PIR element and shall have digital processing facilities and shall be fitted with an EOL 3k3 resistor.

13.5.4 The PIR shall be suitable to operate with a power supply of 9 to 15 VDC and the

currentconsumption shall be 8.7mA.

- 13.5.5 The target speed range of the PIR shall be between 300 mm/s and 30 mm/s.
- 13.5.6 The unit shall be fitted with a Fresnel lens and shall be suitable for operation in a temperaturerange of -10°C and +65°C.
- 13.5.7 The sensor shall comply with UL/CUL and EN50131, Grade 2.
- 13.5.8 The positions of PIR's shown on the layout drawings accompanying this specification.

Detection Range: Coverage diameter of 9.3m at 6.3m mounting height
Optics: Fresnel lens
Power supply: 9 to 15 VDC
Current consumption (nom.): 8.7 mA
Alarm relay: <24 VDC, 50mA, NC
Tamper relay: <24 VDC, 50mA, NC
Target speed range: 30cm/s to 3m/s
Ambient conditions: -10 to +55°C
Relative humidity: Max. 95%
IN50131-2-2: Grade 2
UL/CUL variant: available

13.6 IR BEAMS

Type: Photoelectric Detector
Detection Range: 60m
Features: Quad high power beams, IP65 waterproof structure & Tamper function
Maximum detection range: 60m
Detection method: Quad infrared beam interruption detection
Interruption time: Variable between 50/100/250/500ms.
Power Source: 10.5 - 30 VDC
Operating temperature: -25°C - +60°C
Operating humidity: 95% (max)
Alignment angle: ±90° Horizontal, ±10° Vertical

14. PUBLIC ADDRESS AND INTERCOM SYSTEMS

14.1 GENERAL REQUIREMENTS

- 14.1.1 The PA and intercom (sound) systems required in this contract shall be of the latest modular type and shall be suitable for integration in IP- and/or Fiber Optic networks to allow for any complex design possibility.
- 14.1.2 The PA and Intercom shall interface to the existing PA headend located at City Power Headoffice in Reuven.
- 14.1.3 The sound system shall incorporate public address, evacuation messages and signals, fire alarm evacuation signals, recorded sound media broadcast, intercom systems, etc., on the sites and in the buildings where the equipment is required.
- 14.1.4 "Figure 17.1" herein depicts the sound system configuration in a typical depot site. The intercomat substation sites is specified further herein.

SPECIFICATION FOR INTERGRATED SECURITY SYSTEMS

REFERENCE

REV

CP_TSSPEC_237

1

PAGE

68

172

14.1.5 The audio amplifier equipment shall be of the compact audio controller type suitable for publicaddress and voice evacuation systems. The equipment shall be SANS 50054-16 and BS5839-part 8.

14.1.6 Two type of loudspeakers are required in this Contract i.e. indoor (ceiling or wall mounted) and outdoor horns.

14.2 DIGITAL AUDIO EQUIPMENT

14.2.1 The PA amplifier/controller for the whole audio system on a site, typically on Depot sites shall:

14.2.1.1 Interface directly with speakers of both the indoor and outdoor type

14.2.1.2 Interface directly with micro phones, a fire detection control panel and evacuation alarmcontacts.

14.2.1.3 Be suitable for network connections with an Ethernet switch and with redundant ampliifierequipment via IP connections.

14.2.2 The amplifier/controller shall house:

14.2.2.1 An audio digital signal processor

14.2.2.2 Matrix control functions, digital message player

14.2.2.3 Front panel access with fully monitored fireman microphone

14.2.2.4 Emergency message trigger buttons

14.2.2.5 Amplifier monitoring with hot-swap amplifiers

14.2.2.6 Loudspeaker line impedance monitoring

14.2.3 The unit shall be suitable for the support up to 4 security microphone consoles with color touch pads and 8 secured amplifiers plus 2 back-up amplifiers and paging into 8 different zones per unit.

14.2.4 Each input and output channel shall be fitted with a wide range of pre-and post-processing devices such as, volume controllers, routing mixers and switches, priority and paging components, equalizers, compressors, limiters, delay-lines, etc.

14.2.5 It shall be possible to store 4 hours of digital messages to provide live recording or pre-recorded payback.

14.2.6 The controller shall allow operators to see a detailed overview of the operational status of the entire PA system by using a single button.

14.2.7 The controller shall be able to run an impedance scan of all components connected to it, covering not only the input paging consoles but including connectors, cabling, processing blocks such as compressors and limiters, delay lines and the network and loudspeakers.

14.2.8 The amplifier/controller shall further have the following characteristics:

Interfaces: Standard Local Networking, 2 x RJ45. 100 m.

Ethernet interface: TCP/IP, MOD BUS, Vox-Net and 3rd party devices.

Security microphone connection support: 4 X RJ45, PC1 to PC4: MOD BUS, Vox-Net and 3rdparty devices.

Balanced audio outputs: 8

Audio outputs for back-up amplifiers: 2

Inputs: Return 100 Volt lines input from amplifiers.

Outgoing:	16 (8+8) 100 Volt lines to the loudspeakers.
Optional inputs:	2 slots for 8 mic /line/ digital AES /EBU audio inputs/outputs.
Logic inputs:	9
Logic outputs:	8
Security contacts for:	Evacuation and fault reporting and fault-back inputs
Messages storage:	4 Hours capacity. Playing up to 48 messages simultaneously in a system

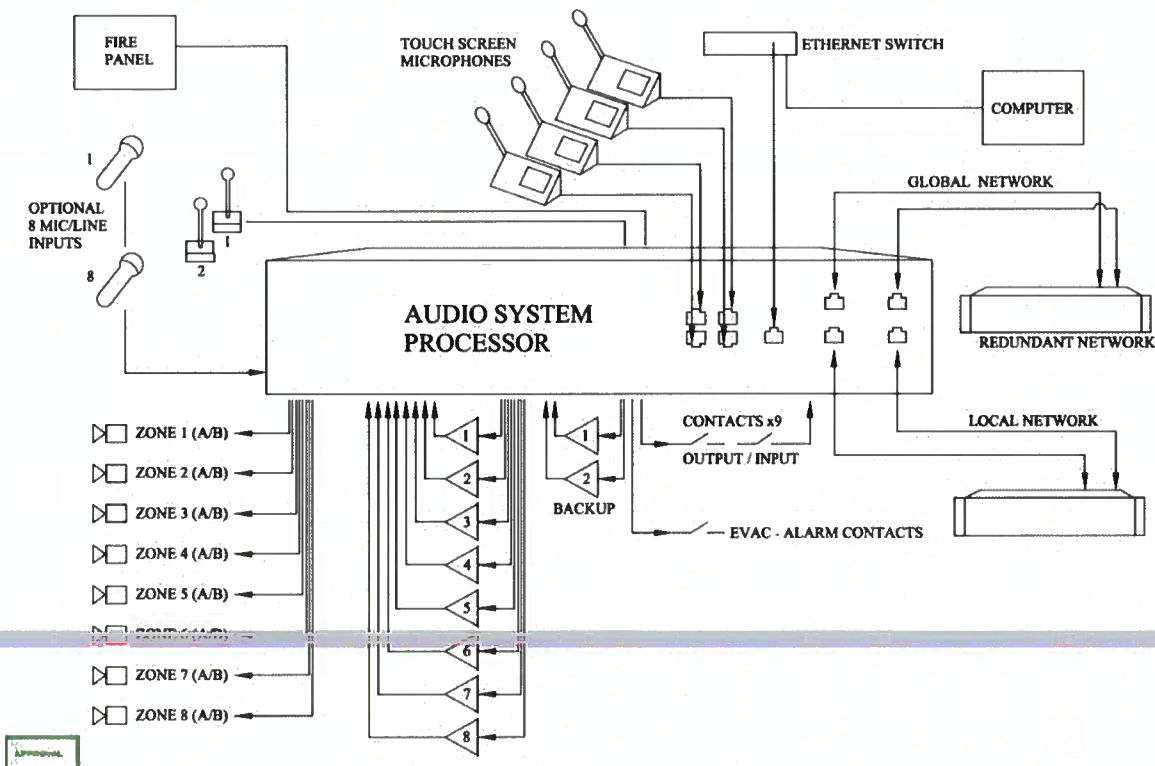

Figure 15: Sound System Configuration

14.3 SECURED CALL STATIONS

- 14.3.1 Secured call stations are required in this contract for use together with the amplifiers/controllers specified in clause "21.2 Digital Audio Equipment" hereof.
- 14.3.2 The stations shall be of the man-machine interface type and shall use a full touch type color screen and shall allow paging calls a message broadcast via a secured Ethernet bus.
- 14.3.3 The station shall be suitable to communicate via a secured Ethernet network with the amplifiers/controllers for remote operation via an extended TCP/IP network or locally directly via an Ethernet network.
- 14.3.4 The unit shall have a metal back and the casing of the top and sides shall be PVC.
- 14.3.5 It shall further be possible to program paging parameters for:
 - 14.3.5.1 Assigning zones to different buttons
 - 14.3.5.2 Enter names of zones

-
- 14.3.5.3 Enter groups of zones
 - 14.3.5.4 Do messages triggering
 - 14.3.5.5 Adjust levels and pre-call chime and also for fader control
 - 14.3.5.6 Program button control or event control.
 - 14.3.6 The messages and the chimes shall be stored in the unit
 - 14.3.7 A total of 12 keys per page, on 14 pages shall allow zone or group of zones selections.
 - 14.3.8 Each key shall contain a green color changing field, to indicate that the zone is occupied by a different process.

14.3.9 The call station shall further have the following characteristics:

- Touch screen:** 5" TFT full color
- LED indicators:** 3 Off – Power, general fault, evacuation active
- Buttons:** 3 Off- User definable
- Microphone:** 280mm flexible
- Front face:** Tilted 30°

14.3.10 "Figure 15: Sound System Configuration" herein depicts a typical example of the desk station.

14.4 INDOOR WALL MOUNTED SPEAKERS

14.4.1 Indoor wall mounted speakers shall consist of an ABS enclosure with a metal grill and shall have a stainless steel mounting bracket. The speaker body, grill and bracket shall be finished in a white color.

14.4.2 The bracket fixing points on the housing shall allow adjustment of the speaker body in the vertical plane.

14.4.3 The wall mounted speakers shall further have the following characteristics:

- RMS rated output:** 15W at 100V
- Line voltage transformer:** 100V – 15W/70V –
- 7.5WSpeakers required in housing:** 4" and 1.5" two way
- Frequency response:** 120Hz – 15 kHz
- Impedance:** 670Ω
- Maximum SPL:** 99dB
- SPL (1W at 1m):** 88dB ± 3dB
- Connection at rear:** Black & Red captive banana plugs

14.4.4 Wall mounted speakers shall be installed at a height of 3000mm above floor level to prevent tampering with the speakers.

14.4.5 The positions of wall mounted speakers are shown on the drawings.

14.5 INDOOR CEILING MOUNTED SPEAKERS

14.5.1 Ceiling mounted speakers shall in general be of fireproof design.

14.5.2 The speaker shall be mounted in a fireproof dome and shall have an aluminium grill and

metal baffle and shall be mountable with a clip-in arrangement.

14.5.3 The fireproof version of the speaker shall have ceramic terminals, a thermal fuse and shall fire resistant internal wiring.

14.5.4 The wall mounted speakers shall further have the following characteristics:

RMS rated output:	6W at 100V
100V Line voltage transformer taps:	6W & 3 W
70V Line voltage taps:	3W & 1.5W
Speakers required in housing:	5"
Frequency response:	110Hz – 14.5 kHz
Impedance:	3.3k Ω /1.7k Ω
Maximum SPL:	98dB
SPL (1W at 1m):	90dB
Connection inside dome:	Black & Red line – ceramic
Mounting:	Spring clip

14.5.5 The positions of ceiling mounted speakers are shown on the drawings.

14.6 OUTDOOR HORN SPEAKERS

14.6.1 Outdoor horn speakers shall be of the wall mounting type and shall be weather-proof.

14.6.2 Horn speakers shall preferably be mounted below roof overhangs and shall be have a wall mount bracket for adjustment of the horn in a vertical or horizontal plane.

14.6.3 The bracket shall be fixed to the sides of the horn and the fixing points shall have bolts to fix the horn in the desired position.

14.6.4 The cable entry shall be of the gripper gland type with a suitable internal seal grommet. The cable entry gland shall be positioned at the 45° downward position when the horn is mounted with the bracket either vertically or horizontally.

14.6.5 The horn speakers shall further have the following characteristics:

RMS rated power:	20W
100V Line voltage transformer taps:	2.5W, 5W, 10W & 20W
Transformer Impedance:	500 Ω , 1k Ω , 2k Ω & 4k Ω
70V Line voltage transformer taps:	1.25W, 2.5W, 5W & 10W
Effective frequency range:	310Hz — 16 kHz
Impedance:	8 Ω
SPL @ 4m, 1W, 1 kHz, 1/3 Octave:	81dB
SPL @ 1m, 1W, 1 kHz, 100Hz-10 kHz:	107dB
SPL @ 4m, full power:	93dB
Dispersion 1 kHz/2kHz:	111/62° Horizontal, 148/84° Vertical
IP Rating:	33
Material:	Low smoke, zero halogen, UL-94VO plastic

14.6.6 The positions of horns shall be indicated on the project drawings provided by City Power or the Consulting Engineer.

14.7 INTERCOM SYSTEM

**SPECIFICATION FOR INTERGRATED
SECURITY SYSTEMS**

REFERENCE

REV

CP_TSSPEC_237

1

PAGE

72

172

- 14.7.1 The intercom stations for outdoor mounting and shall be the surface mounted, vandal resistant, emergency call, type and shall be rated for IP65 conditions.
- 14.7.2 The unit shall be suitable to be POE powered and equipped with a microphone and loudspeaker facilities.
- 14.7.3 The station shall allow excellent speech quality and comprehensibility independent of background noise.
- 14.7.4 The front plate of the unit shall be 3mm stainless steel with poke protection and special tamperfree screws shall be used to fix the front plate to a wall mounted enclosure.
- 14.7.5 The unit shall have a single back-lit button which shall be programmable for direct dialling. The button be labelled shall have an engraved label in a captive mounting.
- 14.7.6 The microphone shall be of the electret type and the unit shall further have 2 x 8Ω loudspeakers.
- 14.7.7 The station shall further have 2 relay outputs with NO or NC contacts.
- 14.7.8 The intercom station shall further have the following characteristics:

IP rating:	IP 65
Mechanical impact resistance acc. EN 62262:	Series WS 200V: IK 09 Series WS 210V: IK 08
Microphone:	Omnidirectional electret microphone for max. 7 m speaking distance
Loudspeaker:	Special membrane type for optimal sound quality, sound pressure: 85 dB/1 W/1 m 2 x 8 Ω
Amplifier:	integrated class "D" amplifier with 2.5 W
Sound pressure:	max. 99 dB
Handset, Headset:	EM sensitivity: 14mVeff EM impedance: 3.3 kΩ / EM supply: 2.5V EP level: 850mVeff at 0 dBm0 / EP impedance: 200Ω
Input:	3 inputs for floating contacts
Output:	2 relay outputs (switch-over contacts) 30 V / 1 A
Line output:	for connection loudspeaker module
Call indication:	multifunction LED (colors: red, green, blue)
Call button:	back-lit direct dialing buttons with label areas only series WS 210V: large red emergency call button
Transmission bandwidth:	16000 Hz
Operating temperature range:	-20° C to 70° C
Storage temperature range:	-20° C to 70° C
Relative humidity:	up to 95% not condensing
Connection:	pluggable screw terminals expansion plug for e.g. WSAM 50V D ME IP Uplink: shielded RJ 45 modular jacks
Power supply:	PoE or external supply

**SPECIFICATION FOR INTERGRATED
SECURITY SYSTEMS**

REFERENCE

REV

CP_TSSPEC_237

1

PAGE 73

172

Cabling:	24 VDC power consumption: max. 4 W min. Cat. 5
PoE (Power over Ethernet):	IEEE 802.3af standard Power consumption of the terminal device: Class 0 (0.44 W to 12.95 W)
Protocol:	VoIP-Protocol based on UDP/IP
Data rate:	10/100 MB/s (Full/Half Duplex)
Mounting:	flush mount kit or surface mount

14.8 VIDEO INTERCOM SYSTEM

- 14.8.1 IP video intercoms shall be strategically place at all substations and shall be used by the individuals requiring access to the site to interface to the central control room at Reuven
- 14.8.2 Video intercoms shall be vandal resistant with built-in color video camera. The technology shall allow for excellent speech quality and comprehensibility independent of background noise. A 3mm stainless steel front panel shall provide poke protection and shall be fixed with special screws for protection against vandalism. The robust construction shall provide full protection against water, dirt and dust — protection class IP 65.

Video Intercom:

IP rating:	IP 65
Mechanical impact resistance acc. EN 62262:	IK 07
Microphone:	Omnidirectional electret microphone for max. 7 m speaking distance
Loudspeaker:	85 dB/1 W/1 m, 2 x 8 Ω
Input:	3 inputs for floating contacts
Output:	2 relay outputs (switch over contacts) 30 V / 1 A
Call button:	Large red emergency call button
Operating temperature range:	-20° C to 60° C
Relative humidity:	Up to 95% not condensing
Power supply:	PoE
Cabling:	Min. Cat. 5
PoE (Power over Ethernet):	IEEE 802.3af standard
Protocol:	IoIP-Protocol based on UDP/IP
Mounting:	Surface mount kit WSSH 50V

Hybrid Camera:

General Data:	Image sensor: ¼ inch color CMOS sensor Lens*: Focal distance 3.6mm, F2,8, fixed aperture, angle 67.4° (diagonal) Automatic adjustment of white fader-, color-, contrast- and brightness parameters Angle adjustable up to 30° horizontally/vertically Resolution: 320 x 240 or 640 x 480 Motion JPEG (MJPEG) Up to 30 pictures per second 10/100 Mbit/s, half-/full duplex
IP video stream:	
Video format:	
Picture rate:	
Ethernet:	

15. QUALITY MANAGEMENT

A quality management system shall be set up in order to assure the quality of the integrated security systems equipment during design, development, production, installation and repairs. Guidance on the requirements for a quality management system shall be found in the following standards: ISO 9001:2000. The details shall be subject to agreement between the City Power and supplier. A quality file shall be submitted by the Contractor within 14 days of appointment.

16. HEALTH AND SAFETY

A health and safety plan shall be set up in order to ensure proper management and compliance of the multi-zone walk through metal detector during installation, operation, maintenance, and decommissioning phases. Guidance on the requirements of a health and safety plan shall be found in ISO 45001:2018 standards. This is to ensure that the asset conforms to standard operating procedures and City Power SHERQ Policy. The details shall be subject to agreement between City Power and the Supplier.

17. ENVIRONMENTAL MANAGEMENT

An environmental management system shall be set up in order to assure the environmental compliance of the integrated security systems equipment throughout its entire life cycle (i.e. during design, development, production, installation, operation and maintenance, decommissioning and disposal phases). Guidance on the requirements for an environmental management system shall be found in ISO 14001 and City Power Policy. The details shall be subject to agreement between the City Power and supplier. An environmental management file shall be submitted by the Contractor within 14 days of appointment.

ANNEXURE A Bibliography

None

ANNEXURE B – Revision information

DATE	REV. NO.	NOTES
October 2016	0	First issue
June 2022	1	Edit entire specification

**SPECIFICATION FOR INTERGRATED
SECURITY SYSTEMS**

REFERENCE

REV

CP_TSSPEC_237

1

PAGE

78

172

CAT 6 CABLE

Deviation Schedule

Any deviations offered to this specification shall be listed below with reasons for deviation. In addition, evidence shall be provided that the proposed deviation shall at least be more cost-effective than that specified by City Power.		
Item	Sub Clause of CP_TSSPEC_237	Proposed deviation

Tender Number: _____

Tenderer's Authorized Signatory: _____
Name in block letters
Signature

Full name of company: _____

**SPECIFICATION FOR INTERGRATED
SECURITY SYSTEMS**

REFERENCE

REV

CP_TSSPEC_237

1

PAGE

80

172

**CAT6 PATCH PANEL
Deviation Schedule**

Any deviations offered to this specification shall be listed below with reasons for deviation. In addition, evidence shall be provided that the proposed deviation shall at least be more cost-effective than that specified by City Power.

Item	Sub Clause of CP_TSSPEC_237	Proposed deviation

Tender Number: _____

Tenderer's Authorized Signatory: _____
Name in block letters
Signature

Full name of company: _____

**SPECIFICATION FOR INTERGRATED
SECURITY SYSTEMS**

REFERENCE

REV

CP_TSSPEC_237

1

PAGE

81

172

20. ITEM NO 3 - OPTIC FIBER CABLE

TECHNICAL SCHEDULES A & B:

Schedule A: Purchaser's specific requirements

Schedule B: Guarantees and technical particulars of equipment offered

Item	Sub-clause CP_TSSPEC- 237	Description	Schedule A	Schedule B
3.	13	<u>OPTIC FIBER CABLES</u>		
3.1.		Specification	OS1 (ISO/IEC)	
3.2.		Mode	Single	
3.3.		Mode Field Diameter (optical) μm	9±3	
3.4.		Cladding Diameter (optical) μm	125±2	
3.5.		Coating diameter (optical) μm	245±10	
3.6.		Wavelength nm	1310 and 1550	
3.7.		Attenuation dB/km	1.0	
3.8.		Bandwidth GHz	1000	
3.9.		Impact Resistance: IEC 60794-1-E4	XXXXX	XXXXX
3.10.		Resistance to water penetration: IEC 60794-1-F4 - test method 5B	XXXXX	XXXXX
3.11.		Fire retardancy: IEC 60332-3	XXXXX	XXXXX
3.12.		Fiber core count	4 and 12	
3.13.		Identification: Printing on cable sheath	XXXXX	XXXXX
3.14.		Outer Sheath: Orange - flame retardant (Indoor cable)	XXXXX	XXXXX
3.15.		Underground OFC		
3.16.		Armour Armour corrugated tape PE/FE/PE - longitudinally (Outdoor cable-Duct cable, Decabon armoured)	XXXXX	XXXXX
3.17.		Water absorbent tape: Under CST	XXXXX	XXXXX
3.18.		Cable bedding: Black - flame retardant	XXXXX	XXXXX
3.19.		Strength member: Aramid yarns	XXXXX	XXXXX
3.20.		Inner core: Gel filled buffered tape	XXXXX	XXXXX
3.21.		Inner 4 fibers: Colored fibers (for ID purposes)	XXXXX	XXXXX
3.22.		Sheath: LSZH - black	XXXXX	XXXXX
3.23.		Minimum bend radius mm	300	
3.24.		Length marking	At 1 m ± 1 %.	
3.25.		Locally Supported	Yes	

Tender Number: _____

**SPECIFICATION FOR INTERGRATED
SECURITY SYSTEMS**

REFERENCE

REV

CP_TSSPEC_237

1

PAGE

82

172

Tenderer's Authorized Signatory: _____

Name in block letters

Signature

Full name of company: _____

**SPECIFICATION FOR INTERGRATED
SECURITY SYSTEMS**

REFERENCE

REV

CP_TSSPEC_237

1

PAGE

83

172

OPTIC FIBER CABLE

Deviation Schedule

Any deviations offered to this specification shall be listed below with reasons for deviation. In addition, evidence shall be provided that the proposed deviation shall at least be more cost-effective than that specified by City Power.

Item	Sub Clause of CP_TSSPEC_237	Proposed deviation

Tender Number: _____

Tenderer's Authorized Signatory: _____
Name in block letters Signature

Full name of company: _____

**SPECIFICATION FOR INTERGRATED
SECURITY SYSTEMS**

REFERENCE
CP_TSSPEC_237
PAGE **84**

REV
1
172

21. ITEM NO 4 – UPS

TECHNICAL SCHEDULES A & B:

Schedule A: Purchaser's specific requirements

Schedule B: Guarantees and technical particulars of equipment offered

Item	Sub-clause CP_TSSPE C-237	Description	Schedule A	Schedule B
4.	15.2	UPS SUPPLY		
4.1.		<u>Size:</u> 3U Rack mountable	XXXXX	XXXXX
4.2.		<u>Output:</u>		
		Output power capacity: hour	8	
		Min. Configurable Power (Watts): kVA	4.0	
		Nominal Output Voltage: V	230V	
		Output Voltage Distortion: %	< 3	
		Output Frequency (sync to mains):	50 Hz +/- 3 Hz user adjustable +/- 0.1	
		Topology:	Pure Sine wave	
		Output Connections: (min. 2) IEC 320 C19 (Battery Backup)	XXXXX	XXXXX
		(min. 2) IEC 320 C13 (Battery Backup)		
		Bypass:	Internal Bypass	
4.3.		<u>Input:</u>		
		Nominal Input Voltage: V	230	
		Input frequency: Hz	50 Hz +/- 5 Hz (auto sensing)	
		Input Connections: IEC-320 C20	XXXXX	XXXXX
4.4.		Input voltage range for main operations: V	160 - 280	
4.5.		Rack Height: (max) U	3	
		<u>Battery:</u>		
		Battery type:		
		Field replaceable, leak-proof, maintenance-free sealed Lead-Acid battery with suspended electrolyte	XXXXX	XXXXX
		Expected Battery Life: years	3 - 5	
		Typical recharge time: (min) hours	2.5	
		Control panel:		
		LED/bar-graph status display with load, battery voltage, On Line, On Battery, Replace Battery, Overload and Bypass	XXXXX	XXXXX

**SPECIFICATION FOR INTERGRATED
SECURITY SYSTEMS**

REFERENCE
CP_TSSPEC_237
PAGE 86

REV
1
172

UPS

Deviation Schedule

Any deviations offered to this specification shall be listed below with reasons for deviation. In addition, evidence shall be provided that the proposed deviation shall at least be more cost-effective than that specified by City Power.

Item	Sub Clause of CP_TSSPEC_237	Proposed deviation

Tender Number: _____

Tenderer's Authorized Signatory: _____
Name in block letters
Signature

Full name of company: _____

**SPECIFICATION FOR INTERGRATED
SECURITY SYSTEMS**

REFERENCE

REV

CP_TSSPEC_237

1

PAGE

87

172

22. ITEM NO 5 – DOOR READER CONTROLLER - POWER SUPPLY

TECHNICAL SCHEDULES A & B:

Schedule A: Purchaser's specific requirements

Schedule B: Guarantees and technical particulars of equipment offered

Item	Sub-clause CP_TSSPEC- 237	Description	Schedule A	Schedule B
5.	15.3	Power Supply Enclosure		
5.1.		Power Output: VDC	24	
5.2.		Rating: Class	2	
5.3.		Power Input:	230 VAC, 50 Hz, 1.9 amp	
5.4.		Maximum Charge Current: 0.7 amp Filtered and electronically regulated outputs Built-in charger for sealed gel type batteries. 100 mV peak output voltage ripple	XXXXX	XXXXX
5.5.		Approvals:	CE-Marked	
5.6.		Locally Supported:	Yes	

Tender Number: _____

Tenderer's Authorized Signatory: _____

Name in block letters

Signature

Full name of company: _____

**SPECIFICATION FOR INTERGRATED
SECURITY SYSTEMS**

REFERENCE
CP_TSSPEC_237
PAGE 88

REV
1
172

DRC POWER SUPPLY

Deviation Schedule

Any deviations offered to this specification shall be listed below with reasons for deviation. In addition, evidence shall be provided that the proposed deviation shall at least be more cost-effective than that specified by City Power.

Item	Sub Clause of CP_TSSPEC_237	Proposed deviation

Tender Number: _____

Tenderer's Authorized Signatory: _____
Name in block letters
Signature

Full name of company: _____

23. ITEM NO 6 – DOOR MAGLOCK POWER SUPPLY

TECHNICAL SCHEDULES A & B:

Schedule A: Purchaser's specific requirements

Schedule B: Guarantees and technical particulars of equipment offered

Item	Sub-clause CP_TSSPEC- 237	Description	Schedule A	Schedule B
6.	15.4	Box Power Supply Switch Mode		
6.1.		Input Voltage:	230 VAC, 50 Hz ±10%	XXXXX
6.2.		Output Voltage: VDC	27.6	
6.3.		Load output: A	4	
6.4.		Total output: A	5	
6.5.		Output ripple (max): mVrms	100	
6.6.		Max. battery size:	7 Ah (x2)	
6.7.		Battery recharge time:	20	
6.8.		Battery disconnect voltage: VDS	19.6 ±0.2	
6.9.		Open collector output:	Open circuit on fault or mains fail -	XXXXX
6.10.		Fuse 12/24 V output: A	5	
6.11.		Fuse 230 VAC input: A	3.15	
6.12.		Operating temperature: °C	-10 to +40	
6.13.		Relative humidity: %	95	
6.14.		Housing (steel) powder coated: mm	1.2	
6.15.		Locally Supported:	Yes	

Tender Number: _____

Tenderer's Authorized Signatory: _____
Name in block letters
Signature

Full name of company: _____

**SPECIFICATION FOR INTERGRATED
SECURITY SYSTEMS**

REFERENCE
CP_TSSPEC_237
PAGE **90**

REV
1
172

DOOR MAGLOCK POWER SUPPLY

Deviation Schedule

Any deviations offered to this specification shall be listed below with reasons for deviation. In addition, evidence shall be provided that the proposed deviation shall at least be more cost-effective than that specified by City Power.

Item	Sub Clause of CP_TSSPEC_237	Proposed deviation

Tender Number: _____

Tenderer's Authorized Signatory: _____
Name in block letters
Signature

Full name of company: _____

24. ITEM NO 7– SYSTEM INTERFACE CONTROLLER

TECHNICAL SCHEDULES A & B:

Schedule A: Purchaser's specific requirements

Schedule B: Guarantees and technical particulars of equipment offered

Item	Sub-clause CP_TSSPEC- 237	Description	Schedule A	Schedule B
7.	16.2	Controller		
7.1.		DC input:	24 VDC ± 15%. 500 mA maximum	
7.2.		Memory and Clock backup:	3 V lithium, type CR2330	
7.3.		<u>Communication Ports</u> Primary (Ethernet) Port:	10/100Base-T Ethernet high- speed port	
		Alternate Upstream Port 1:	RS-232 9600 to 115.2 Kbps async	
		Downstream Port 2:	RS-485 (2-wire) 9600 to 38.4 Kbps async	
7.4.		<u>Inputs</u> Tamper and Power Fail Monitors:	Unsupervised, dedicated	
		Door position, REX, and AUX:	8, each programmable as normally open or normally closed, supervised or unsupervised circuits	
7.5.		<u>Outputs</u> Relay outputs	4 Form-C 5 A at 30 VDC relay outputs: 2 strike, 2 auxiliary	
7.6.		<u>Reader Power</u> DC output Reader Port Compatibility	12 VDC, 125 mA Wiegand Data1/Data0, Magnetic Clock/Data,	

SPECIFICATION FOR INTERGRATED SECURITY SYSTEMS

REFERENCE
CP_TSSPEC_237
 PAGE **92**

REV
1
 172

			F/2F single-wire protocol, Bioscrypt RS-485 OSDP (Open Supervised Device Protocol RS-485)
7.7.		<u>Environmental</u> Operating Temperature °C Storage Temperature °C Humidity % RHNC	0 - +70 -55 - +85 0 to 95
7.8.		<u>Mechanical</u> Approvals Supported Readers	UL 294, CE-marked, RoHS compliant Schlage Wireless - WA 5296, WA 5696, WA 5694, WA 993, WRI, WPR
7.9.		Approvals	FCC Part 15, CE, RoHS, UL 294, UL 1076, ULC CSA-C22.2, CAN/ULC-S319-05, cUL/ORD C1076
7.10.		Locally Supported	Yes

Tender Number: _____

Tenderer's Authorized Signatory: _____
 Name in block letters Signature

Full name of company: _____

SYSTEM INTERFACE CONTROLLER

Deviation Schedule

Any deviations offered to this specification shall be listed below with reasons for deviation. In addition, evidence shall be provided that the proposed deviation shall at least be more cost-effective than that specified by City Power.

Item	Sub Clause of CP_TSSPEC_237	Proposed deviation

Tender Number: _____

Tenderer's Authorized Signatory: _____
Name in block letters
Signature

Full name of company: _____

SPECIFICATION FOR INTERGRATED SECURITY SYSTEMS

REFERENCE
CP_TSSPEC_237
 PAGE 94

REV
1
 172

25. ITEM NO 8 – DOOR READER CONTROLLER

TECHNICAL SCHEDULES A & B:

Schedule A: Purchaser's specific requirements

Schedule B: Guarantees and technical particulars of equipment offered

Item	Sub-clause CP_TSSPEC- 237	Description	Schedule A	Schedule B
8.	16.3	Dual Reader		
8.1.		Primary Power	24 Vdc ±10%,	
8.2.		Outputs	6 outputs, Form-C, 5A @ 28Vdc, resistive	
8.3.		Inputs	8 unsupervised/supervised, standard EOL: 1k/1k ohm, 1% 1/4 watt	
8.4.		Reader Interface	2 unsupervised, dedicated for cabinet tamper and UPS fault monitoring Reader power: 24Vdc ±10% regulated, 125mA maximum each	
8.5.		Reader Port Compatibility	Wiegand Data 1/Data 0 Magnetic Clock/Data F/2F Single Wire Open Supervised Device Protocols	
8.6.		Environmental Temperature	Operating: 0°C to +70°C Storage: -55°C to +85°C	
8.7.		Humidity	0% to 95% RHNC	
8.8.		Compliance Approvals	FCC Part 15, CE, RoHS, UL 294, UL 1076, ULC CSA-C22.2, CAN/ULC- S319-05, cUL/ORD- C1076	
8.9.		Locally Supported	Yes	

Tender Number: _____

Tenderer's Authorized Signatory: _____
 Name in block letters Signature

Full name of company: _____

DOOR READER CONTROLLER

Deviation Schedule

Any deviations offered to this specification shall be listed below with reasons for deviation. In addition, evidence shall be provided that the proposed deviation shall at least be more cost-effective than that specified by City Power.

Item	Sub Clause of CP_TSSPEC_237	Proposed deviation

Tender Number: _____

Tenderer's Authorized Signatory: _____
Name in block letters
Signature

Full name of company: _____

SPECIFICATION FOR INTERGRATED SECURITY SYSTEMS

REFERENCE
CP_TSSPEC_237
 PAGE 96

REV
1
 172

26. - ITEM NO 9- CARD READER

TECHNICAL SCHEDULES A & B:

Schedule A: Purchaser's specific requirements

Schedule B: Guarantees and technical particulars of equipment offered

Item	Sub-clause CP_TSSPEC- 237	Description	Schedule A	Schedule B
9.	16.4	Card Reader		
9.1.		Mounting	Mini-Mullion Size	
9.2.		Color	Black	
9.3.		Material	UL94 Polycarbonate	
9.4.		Panel Connection	Pigtail or Terminal strip depending on product type	
9.5.		Power Supply	5 - 16 VDC Linear Supply	
9.6.		<u>Standard Power Mode</u> Current Requirements	45 mA @ 24 VDC Avg/Peak	
		13,56 Mhz Card Compatibility	Secure Identity Object™ (SIO) on iCLASS SE/SR, SE for MIFARE DESFire EV1 and SE for MIFARE Classic (On by Default)	
			Standard iCLASS	
			Access Control Application (order with Standard interpreter) ISO14443A (MIFARE) CSN, ISO14443B CSN, ISO15693 CSN	XXXXX
9.7.		<u>Typical Maximum Read Range</u> 13.56 MHz Single Technology ID-1 Credentials (Cards) - SIO Data Model	iCLASS® SE™: 7.1cm SE for DESFire® EV1: 4.1 cm	XXXXX
		13.56 MHz Single Technology Tags/Fobs - SIO data Model	SE for MIFARE® Classic: 6.6cm iCLASS SE: 3.8cm SE for MIFARE Classic: 3.0cm	XXXXX
9.8.		Cable Distance m	150m	
9.9.		Operating Temperature °C	-35 - 65	
9.10.		Relative humidity %	5 - 95	
9.11.		Transmit Frequency MHz	13.56	
9.12.		Interface	Wiegand or OSDP	

**SPECIFICATION FOR INTERGRATED
SECURITY SYSTEMS**

REFERENCE

REV

CP_TSSPEC_237

1

PAGE 97

172

9.13.	Environmental Rating	IP55	
9.14.	Locally Supported	Yes	

Tender Number: _____

Tenderer's Authorized Signatory: _____

Name in block letters

Signature

Full name of company: _____

CARD READER

Deviation Schedule

<p>Any deviations offered to this specification shall be listed below with reasons for deviation. In addition, evidence shall be provided that the proposed deviation shall at least be more cost-effective than that specified by City Power.</p>		
Item	Sub Clause of CP_TSSPEC_237	Proposed deviation

Tender Number: _____

Tenderer's Authorized Signatory: _____
Name in block letters
Signature

Full name of company: _____

27. ITEM NO 10 – EMERGENCY EXIT BREAK-GLASS

TECHNICAL SCHEDULES A & B:

Schedule A: Purchaser's specific requirements

Schedule B: Guarantees and technical particulars of equipment offered

Item	Sub-clause CP_TSSPEC- 237	Description	Schedule A	Schedule B
10.	16.5	Breakglass		
10.1.		Cable Termination mm ²	0.5 - 2.5	
10.2.		Max. contact rating	2A @ 30	
		<u>Mechanical</u>	VDC	
10.3.		Material	PC/ABS	
10.4.		Color	Green	
		<u>Environmental</u>		
10.5.		Operating temperature °C	-10 - +55	
10.6.		Storage temperature °C	-10 - +55	
10.7.		Relative humidity %	0-95	
10.8.		IP Rating	IP24D	
10.9.		Locally Supported	Yes	

Tender Number: _____

Tenderer's Authorized Signatory: _____

Name in block letters

Signature

Full name of company: _____

**SPECIFICATION FOR INTERGRATED
SECURITY SYSTEMS**

REFERENCE
CP_TSSPEC_237
PAGE **100**

REV
1
172

EMERGENCY EXIT BREAK-GLASS

Deviation Schedule

Any deviations offered to this specification shall be listed below with reasons for deviation. In addition, evidence shall be provided that the proposed deviation shall at least be more cost-effective than that specified by City Power.		
Item	Sub Clause of CP_TSSPEC_237	Proposed deviation

Tender Number: _____

Tenderer's Authorized Signatory: _____
Name in block letters
Signature

Full name of company: _____

28. ITEM NO 11 – MAGLOCK

TECHNICAL SCHEDULES A & B:

Schedule A: Purchaser's specific requirements

Schedule B: Guarantees and technical particulars of equipment offered

Item	Sub-clause CP_TSSPEC- 237	Description	Schedule A	Schedule B
11.	16.7	Maglock		
11.1.		Mount	Surface	
11.2.		Holding force	300	
11.3.		Input Voltage	24	
11.4.		Current draw	440 mA	
			(±2.5% @ 13.5 V)	
11.5.		Bi color LED	Yes	
11.6.		Door status switch	No	
11.7.		Monitored changeover	Yes	
11.8.		Magnetic bond sensor	Yes	
11.9.		Locally Supported	Yes	

Tender Number: _____

Tenderer's Authorized Signatory: _____

Name in block letters

Signature

Full name of company: _____

**SPECIFICATION FOR INTERGRATED
SECURITY SYSTEMS**

REFERENCE

REV

CP_TSSPEC_237

1

PAGE

102

172

MAGLOCK

Deviation Schedule

Any deviations offered to this specification shall be listed below with reasons for deviation. In addition, evidence shall be provided that the proposed deviation shall at least be more cost-effective than that specified by City Power.

Item	Sub Clause of CP_TSSPEC_237	Proposed deviation

Tender Number: _____

Tenderer's Authorized Signatory: _____
Name in block letters Signature

Full name of company: _____

29. ITEM NO 12 – VISITOR MANAGEMENT SCANNER

TECHNICAL SCHEDULES A & B:

Schedule A: Purchaser's specific requirements

Schedule B: Guarantees and technical particulars of equipment offered

Item	Sub-clause CP_TSSPEC- 237	Description	Schedule A	Schedule B
12.	16.10	Visitor Scanner		
12.1.		<u>Core:</u> RAM: MB Serial Flash: MB Flash: kB CPU: Operating System:	8 4 512 32 bit ARM RISK processor MaxID Sapphire Rapid Application Development Environment	
12.2.		<u>Peripherals:</u> Barcode Reader: Display:	1D / 2D barcodes 160 x 100	
12.3.		<u>Communications:</u> USB: WLAN:	pixel graphic LCD with back light & grey scale USB 1.1/2.0 full speed Standard IEEE 802.11b/g Wi-Fi WEP. WPA/WPA2 (PSK & Enterprise)	
12.4.		<u>Regulatory:</u> ICASA: TA-2009/1314-SABS CISPR22 (Radiated & conducted emissions) Health & Safety:	Required	

VISITOR MANAGEMENT SCANNER

Deviation Schedule

Any deviations offered to this specification shall be listed below with reasons for deviation. In addition, evidence shall be provided that the proposed deviation shall at least be more cost-effective than that specified by City Power.

Item	Sub Clause of CP_TSSPEC_237	Proposed deviation

Tender Number: _____

Tenderer's Authorized Signatory: _____
Name in block letters
Signature

Full name of company: _____

30. ITEM NO 13 – GATE MOTOR

TECHNICAL SCHEDULES A & B:

Schedule A: Purchaser's specific requirements

Schedule B: Guarantees and technical particulars of equipment offered

Item	Sub-clause CP_TSSPEC -237	Description	Schedule A	Schedule B
13.	16.11	Gate Motor		
13.1.		Input Voltage	220V - 240V ± 10%, 50Hz	
13.2.		Motor Voltage	24	
13.3.		Motor Power Supply	Battery Driven (2 x 7Ah)	
13.4.		Battery Charger	2A @ 27.5V	
13.5.		Current (mains)	170	
13.6.		Current (motor at rated load)	8	
13.7.		Operator push force Starting	20	
13.8.		Operator push forced Rated	15	
13.9.		Maximum gate length	50	
13.10.		Maximum gate speed	40-50	
13.11.		Manual override	Lockable lever with key release	
13.12.		Maximum number of operations per day	750	
13.13.		Duty cycle	25	
13.14.		Operations in standby with 2 x 7Ah batteries		
		Half day	58	
		Full day	37	
13.15.		Collision sensing	Electronic	
13.16.		Operating temperature range	-15 - +50	
13.17.		Integration	Controlled with access control system	
13.18.		Locally Supported	Yes	

Tender Number: _____

Tenderer's Authorized Signatory: _____
Name in block letters Signature

Full name of company: _____

SPECIFICATION FOR INTERGRATED SECURITY SYSTEMS

REFERENCE

REV

CP_TSSPEC_237

1

PAGE

107

169

GATE MOTOR

Deviation Schedule

Any deviations offered to this specification shall be listed below with reasons for deviation. In addition, evidence shall be provided that the proposed deviation shall at least be more cost-effective than that specified by City Power.

Item	Sub Clause of CP_TSSPEC_237	Proposed deviation

Tender Number: _____

Tenderer's Authorized Signatory: _____
Name in block letters
Signature

Full name of company: _____

DEPOT MAIN GATE ENTRANCE TURNSTILE

Deviation Schedule

Any deviations offered to this specification shall be listed below with reasons for deviation. In addition, evidence shall be provided that the proposed deviation shall at least be more cost-effective than that specified by City Power.

Item	Sub Clause of CP_TSSPEC_237	Proposed deviation

Tender Number: _____

Tenderer's Authorized Signatory: _____

Name in block letters

Signature

Full name of company: _____

**SPECIFICATION FOR INTERGRATED
SECURITY SYSTEMS**

REFERENCE

REV

CP_TSSPEC_237

1

PAGE

111

172

DEPOT MAIN BUILDING ENTRANCE SPEEDSTILE MOTION

Deviation Schedule

Any deviations offered to this specification shall be listed below with reasons for deviation. In addition, evidence shall be provided that the proposed deviation shall at least be more cost-effective than that specified by City Power.

Item	Sub Clause of CP_TSSPEC_237	Proposed deviation

Tender Number: _____

Tenderer's Authorized Signatory: _____
Name in block letters
Signature

Full name of company: _____

SPECIFICATION FOR INTERGRATED SECURITY SYSTEMS

REFERENCE

REV

CP_TSSPEC_237

1

PAGE

112

172

33. - ITEM NO 16 – VEHICLE BOOM

TECHNICAL SCHEDULES A & B:

Schedule A: Purchaser's specific requirements

Schedule B: Guarantees and technical particulars of equipment offered

Item	Sub-clause CP_TSSPEC-237	Description	Schedule A	Schedule B
16.	16.14	Vehicle Boom		
16.1.		Input Voltage	240V AC ± 10%, 50Hz	
16.2.		Motor Voltage	12 V DC	
16.3.		Motor Power Supply	Battery-driven (7Ah)	
16.4.		Battery Charger	1.8A @13.8V	
16.5.		Current Consumption (mains)	170 mA	
16.6.		Boom pole length	3.0 m 4.5 6.0	
16.7.		Boom pole raise time (adjustable)	1.2 sec 3 3	
16.8.		Maximum number of operations per day	3000	
16.9.		Duty cycle - mains present	80 %	
16.10		Operations in standby with 7 Ah battery		
		Half day	3000	
		Full day	3000	
16.11		Collision sensing	Electronic	
16.12		Operating temperature range	-15 - +65 °C	
16.13		Traffic Barrier pedestrian fence on boom	Yes	
16.14		Locally Supported	Yes	

Tender Number: _____

Tenderer's Authorized Signatory: _____
 Name in block letters Signature

Full name of company: _____

**SPECIFICATION FOR INTERGRATED
SECURITY SYSTEMS**

REFERENCE

REV

CP_TSSPEC_237

1

PAGE

113

172

VEHICLE BOOM

Deviation Schedule

Any deviations offered to this specification shall be listed below with reasons for deviation. In addition, evidence shall be provided that the proposed deviation shall at least be more cost-effective than that specified by City Power.		
Item	Sub Clause of CP_TSSPEC_237	Proposed deviation

Tender Number: _____

Tenderer's Authorized Signatory: _____
Name in block letters
Signature

Full name of company: _____

SPECIFICATION FOR INTERGRATED SECURITY SYSTEMS

REFERENCE
CP_TSSPEC_237
 PAGE 114

REV
1
 172

34. - ITEM NO 17 – PERIMETER CAMERAS

TECHNICAL SCHEDULES A & B:

Schedule A: Purchaser's specific requirements
 Schedule B: Guarantees and technical particulars of equipment offered

Item	Sub-clause CP_TSSPEC- 237	Description	Schedule A	Schedule B
17.	17.2	Perimeter Camera		
17.1.		Type: Outdoor Fixed Network Camera	Required	
17.2.		Lens - Standard:	F1.3, IR corrected, Megapixel resolution, P-Iris	
17.3.		Lens - Telephoto:	12.5-50 mm P-Iris, F1.4	
17.4.		Resolution:	1080p 25/30 fps (WDR): 1920x1080 to 160x90 Lightfinder and WDR	
17.5.		Light Sensitivity:	Color: 0.18 lux, B/W: 0.04 lux, F1.3 1080p 50/60 fps: Color 0.36 lux, B/W: 0.08 lux, F1.3	
17.6.		Operating temperature: °C	-40 - 50	
17.7.		Casing:	IP66 rated	
17.8.		Analytics:	Cross Line Detection (Trip Wire), Video Motion Detection	
17.9.		Locally Supported	Yes	

Tender Number: _____

Tenderer's Authorized Signatory: _____
 Name in block letters Signature

Full name of company: _____

**SPECIFICATION FOR INTERGRATED
SECURITY SYSTEMS**

REFERENCE

REV

CP_TSSPEC_237

1

PAGE

115

172

PERIMETER CAMERAS

Deviation Schedule

Any deviations offered to this specification shall be listed below with reasons for deviation. In addition, evidence shall be provided that the proposed deviation shall at least be more cost-effective than that specified by City Power.

Item	Sub Clause of CP_TSSPEC_237	Proposed deviation

Tender Number: _____

Tenderer's Authorized Signatory: _____
Name in block letters
Signature

Full name of company: _____

**SPECIFICATION FOR INTERGRATED
SECURITY SYSTEMS**

REFERENCE

REV

CP_TSSPEC_237

1

PAGE

117

172

DOOR CAMERAS

Deviation Schedule

Any deviations offered to this specification shall be listed below with reasons for deviation. In addition, evidence shall be provided that the proposed deviation shall at least be more cost-effective than that specified by City Power.

Item	Sub Clause of CP_TSSPEC_237	Proposed deviation

Tender Number: _____

Tenderer's Authorized Signatory: _____
Name in block letters
Signature

Full name of company: _____

SPECIFICATION FOR INTERGRATED SECURITY SYSTEMS

REFERENCE
CP_TSSPEC_237
 PAGE 118

REV
1
 172

36. - ITEM NO 19 – VEHICLE LICENSE CAMERA

TECHNICAL SCHEDULES A & B:

37.

Schedule A: Purchaser's specific requirements
 Schedule B: Guarantees and technical particulars of equipment offered

Item	Sub-clause CP_TSSPEC- 237	Description	Schedule A	Schedule B
19.	17.4	Vehicle Licence Camera		
19.1.		Type:	Outdoor Fixed Network Camera with IR illumination	
19.2.		Lens:	Varifocal, 3.0-10.5 mm, F1.4	
19.3.		Light Sensitivity:	Color: 0.25 lux, F1.4 B/W: 0.05 lux, F1.4, 0 lux with IR illumination on.	
19.4.				
19.5.		Resolution:	720p 25 fps	
19.6.		Operating temperature: °C	-30 - 50	
19.7.		Casing:	IP66 rated	
19.8.		Analytics:	Video Motion Detection	
19.9.		Locally Supported	Yes	

Tender Number: _____

Tenderer's Authorized Signatory: _____
 Name in block letters Signature

Full name of company: _____

**SPECIFICATION FOR INTERGRATED
SECURITY SYSTEMS**

REFERENCE

REV

CP_TSSPEC_237

1

PAGE

119

172

VEHICLE LICENSE CAMERA

Deviation Schedule

Any deviations offered to this specification shall be listed below with reasons for deviation. In addition, evidence shall be provided that the proposed deviation shall at least be more cost-effective than that specified by City Power.

Item	Sub Clause of CP_TSSPEC_237	Proposed deviation

Tender Number: _____

Tenderer's Authorized Signatory: _____
Name in block letters
Signature

Full name of company: _____

**SPECIFICATION FOR INTERGRATED
SECURITY SYSTEMS**

REFERENCE

REV

CP_TSSPEC_237

1

PAGE

120

172

38. ITEM NO 20 – DOME CAMERAS

TECHNICAL SCHEDULES A & B:

Schedule A: Purchaser's specific requirements

Schedule B: Guarantees and technical particulars of equipment offered

Item	Sub-clause CP_TSSPEC- 237	Description	Schedule A	Schedule B
20.1.	17.5	Dome Camera Type:	Fixed Dome Network Camera	
20.2.		Lens:	F2.8, Fixed iris, Megapixel resolution 2.8 mm	
20.3.		Light Sensitivity:	1.5-100000 lux, F2.8	
20.4.		Resolution:	1280x800 to 320x240 25fps	
20.5.		Operating temperature: °C	0 - 45	
20.6.		Housing:	IP42 rated	
20.7.		Analytics:	Video Motion Detection	
20.8.		Locally Supported	Yes	

Tender Number: _____

Tenderer's Authorized Signatory: _____
Name in block letters
Signature

Full name of company: _____

**SPECIFICATION FOR INTERGRATED
SECURITY SYSTEMS**

REFERENCE

REV

CP_TSSPEC_237

1

PAGE

121

172

DOME CAMERAS

Deviation Schedule

Any deviations offered to this specification shall be listed below with reasons for deviation. In addition, evidence shall be provided that the proposed deviation shall at least be more cost-effective than that specified by City Power.

Item	Sub Clause of CP_TSSPEC_237	Proposed deviation

Tender Number: _____

Tenderer's Authorized Signatory: _____
Name in block letters
Signature

Full name of company: _____

**SPECIFICATION FOR INTERGRATED
SECURITY SYSTEMS**

REFERENCE

REV

CP_TSSPEC_237

1

PAGE

122

172

39. ITEM NO 21 – DOME CAMERA LONG RANGE

TECHNICAL SCHEDULES A & B:

Schedule A: Purchaser's specific requirements

Schedule B: Guarantees and technical particulars of equipment offered

Item	Sub-clause CP_TSSPEC- 237	Description	Schedule A	Schedule B
21.	17.6	Dome Camera Long Range		
21.1.		Type:	Fixed Dome Network Camera	
21.2.		Lens:	Varifocal, 3.0- 10.5 mm, F1.4	
21.3.		Light Sensitivity:	Color: 0.25 lux, F1.4 B/W: 0.05 lux, F1.4	
21.4.			Color: 0.25 lux, F1.4 B/W: 0.05 lux, F1.4	
21.5.		Resolution:	1920x1080 to 160x90 25fps	
21.6.		Operating temperature: °C	0 to 50	
21.7.		Casing:	IP42 rated	
21.8.		Analytics:	Video Motion Detection	
21.9.		Locally Supported	Yes	

Tender Number: _____

Tenderer's Authorized Signatory: _____
Name in block letters Signature

Full name of company: _____

**SPECIFICATION FOR INTERGRATED
SECURITY SYSTEMS**

REFERENCE

REV

CP_TSSPEC_237

1

PAGE

123

172

DOME CAMERA LONG RANGE

Deviation Schedule

Any deviations offered to this specification shall be listed below with reasons for deviation. In addition, evidence shall be provided that the proposed deviation shall at least be more cost-effective than that specified by City Power.

Item	Sub Clause of CP_TSSPEC_237	Proposed deviation

Tender Number: _____

Tenderer's Authorized Signatory: _____
Name in block letters Signature

Full name of company: _____

**SPECIFICATION FOR INTERGRATED
SECURITY SYSTEMS**

REFERENCE
CP_TSSPEC_237
PAGE 124

REV
1
172

40. - ITEM NO 22 – PTZ CAMERA

TECHNICAL SCHEDULES A & B:

Schedule A: Purchaser's specific requirements
Schedule B: Guarantees and technical particulars of equipment offered

Item	Sub-clause CP_TSSPEC- 237	Description	Schedule A	Schedule B
22.	17.7	PTZ Camera		
22.1.		Type:	PTZ Dome Network Camera	
22.2.		Lens:	f=4.3-129 mm, F1.6-4.7, Autofocus, Autoliris, 58.3° - 2.1° view	
22.3.		Light Sensitivity:	Color: 0.15 lux at 30 IRE F1.6 B/W: 0.008 lux at 30 IRE F1.6	
22.4.		Resolution:	280x720 (720p) to 240x135, 25fps	
22.5.		Pan:	360° endless, 0.05-700°/s	
22.6.		Tilt:	+20 to -90° with nadir flip, 0.05-500°/s	
22.7.		Zoom:	30x Optical, 12x Digital, Total 360x zoom	
22.8.		Operating temperature:	°C -50 - +50	
22.9.		Wide Dynamic Range (WDR):	dB 130	
22.10		Casing:	IP66 rated	
22.11		Analytics:	Video Motion Detection, Auto Tracking	
22.12		Locally Supported	Yes	

**SPECIFICATION FOR INTERGRATED
SECURITY SYSTEMS**

REFERENCE

REV

CP_TSSPEC_237

1

PAGE

125

172

Tender Number: _____

Tenderer's Authorized Signatory: _____
Name in block letters Signature

Full name of company: _____

**SPECIFICATION FOR INTERGRATED
SECURITY SYSTEMS**

REFERENCE

REV

CP_TSSPEC_237

1

PAGE

126

172

PTZ CAMERA

Deviation Schedule

Any deviations offered to this specification shall be listed below with reasons for deviation. In addition, evidence shall be provided that the proposed deviation shall at least be more cost-effective than that specified by City Power.

Item	Sub Clause of CP_TSSPEC_237	Proposed deviation

Tender Number: _____

Tenderer's Authorized Signatory: _____
Name in block letters
Signature

Full name of company: _____

**SPECIFICATION FOR INTERGRATED
SECURITY SYSTEMS**

REFERENCE

REV

CP_TSSPEC_237

1

PAGE

127

172

41. ITEM NO 23 – TEMP ALARM CAMERAS FOR CONDITION MONITORING

TECHNICAL SCHEDULES A & B:

Schedule A: Purchaser's specific requirements

Schedule B: Guarantees and technical particulars of equipment offered

Item	Sub-clause CP_TSSPEC- 237	Description	Schedule A	Schedule B
23.	17.8	Thermal Camera		
23.1.		Type:	Temperature Alarm Camera	
23.2.		Camera Sensor:	Sun-Safe Uncooled Micro- bolometer	
23.3.		Resolution:	640 x 480 384 x 288 pixels	
23.4.		Temporal NETD:	50 mK at f/1.0	
23.5.		Temperature Range: °C	-40 - 50	
23.6.		Power Supply: VDC	24	
23.7.		Housing:	IP66 rated	
23.8.		Locally Supported	Yes	

Tender Number: _____

Tenderer's Authorized Signatory: _____
Name in block letters
Signature

Full name of company: _____

**SPECIFICATION FOR INTERGRATED
SECURITY SYSTEMS**

REFERENCE

REV

CP_TSSPEC_237

1

PAGE

128

172

TEMP. ALARM CAMERAS FOR CONDITION MONITORING

Deviation Schedule

Any deviations offered to this specification shall be listed below with reasons for deviation. In addition, evidence shall be provided that the proposed deviation shall at least be more cost-effective than that specified by City Power.

Item	Sub Clause of CP_TSSPEC_237	Proposed deviation

Tender Number: _____

Tenderer's Authorized Signatory: _____
Name in block letters
Signature

Full name of company: _____

**SPECIFICATION FOR INTERGRATED
SECURITY SYSTEMS**

REFERENCE
CP_TSSPEC_237
PAGE 129

REV
1
172

42. ITEM NO 24 – VIDEO RECORDERS

TECHNICAL SCHEDULES A & B:

Schedule A: Purchaser's specific requirements

Schedule B: Guarantees and technical particulars of equipment offered

Item	Sub-clause CP_TSSPEC- 237	Description	Schedule A	Schedule B
24.	17.10	Video Recorders		
24.1.		IP Recording Rate Mbps	240	
24.2.		Channel Count	60	
24.3.		Storage Options TB	24	
24.4.		Chassis Type	3U 19 inch rack-mount chassis	
24.5.		CPU	Xeon E3- 1275v2 3.5GHz Quad Core	
24.6.		Operating System	Latest Windows Professional 64-bit	
24.7.		RAM	8GB DDR3 (4 x 2GB) 1600MHz	
24.8.		On-board NICs	Dual 10/100/1000 Ethernet ports	
24.9.		Optical Drive	CD/RW- DVD/RW	
24.10		Operating System Drive(s)	1 x 250GB internal SATA hard drive	
24.11		RAID Controller	Adaptec 8805 RAID controller	
24.12		Video Storage	Up to 8 SATA 7200 RPM hard drives	
24.13		Serial Port	2 x serial ports	
24.14		USB Ports	4 x USB 2.0	

SPECIFICATION FOR INTERGRATED SECURITY SYSTEMS

REFERENCE

REV

CP_TSSPEC_237

1

PAGE

130

172

24.15	Video Output		1 x VGA, 1 x DVI-D
24.16	Power Supply		Dual 420W, 8-5A redundant power supplies
24.17	Rail Kit		Rack-mount rail kit
24.18	Operating Temperature	°C	5 - 40
24.19	Regulatory Compliance		CE, FCC (Class A), UL 60950, ROHS
24.20	Locally Supported		Yes

Tender Number: _____

Tenderer's Authorized Signatory: _____
 Name in block letters Signature

Full name of company: _____

**SPECIFICATION FOR INTERGRATED
SECURITY SYSTEMS**

REFERENCE

REV

CP_TSSPEC_237

1

PAGE

131

172

VIDEO RECORDERS

Deviation Schedule

Any deviations offered to this specification shall be listed below with reasons for deviation. In addition, evidence shall be provided that the proposed deviation shall at least be more cost-effective than that specified by City Power.

Item	Sub Clause of CP_TSSPEC_237	Proposed deviation

Tender Number: _____

Tenderer's Authorized Signatory: _____
Name in block letters
Signature

Full name of company: _____

**SPECIFICATION FOR INTERGRATED
SECURITY SYSTEMS**

REFERENCE

REV

CP_TSSPEC_237

1

PAGE

132

172

43. ITEM NO 25 – INFRARED ILLUMINATORS

TECHNICAL SCHEDULES A & B:

Schedule A: Purchaser's specific requirements

Schedule B: Guarantees and technical particulars of equipment offered

Item	Sub-clause CP_TSSPEC- 237	Description	Schedule A	Schedule B
25.	17.12	Infrared Illuminators		
25.1.		Optics	SMT LED's	
25.2.		Power Consumption (max) W	120	
25.3.		Power supply input VAC	230	
25.4.		Voltage output (current controlled) V	13.5	
25.5.		Temp Range °C	-50 - +50	
25.6.		Cable Length m	2.5	
25.7.		Color	Black	
25.8.		Wavelength nm	850 or 940	
25.9.		Photocell	Adjustable	
25.10		Locally Supported	Yes	

Tender Number: _____

Tenderer's Authorized Signatory: _____
Name in block letters
Signature

Full name of company: _____

**SPECIFICATION FOR INTERGRATED
SECURITY SYSTEMS**

REFERENCE

REV

CP_TSSPEC_237

1

PAGE

133

172

INFRARED ILLUMINATORS

Deviation Schedule

Any deviations offered to this specification shall be listed below with reasons for deviation. In addition, evidence shall be provided that the proposed deviation shall at least be more cost-effective than that specified by City Power.

Item	Sub Clause of CP_TSSPEC_237	Proposed deviation

Tender Number: _____

Tenderer's Authorized Signatory: _____
Name in block letters Signature

Full name of company: _____

**SPECIFICATION FOR INTERGRATED
SECURITY SYSTEMS**

REFERENCE
CP_TSSPEC_237
PAGE 134

REV
1
172

44. ITEM NO 26 – FIRE ALARM CONTROL PANEL

TECHNICAL SCHEDULES A & B:

Schedule A: Purchaser's specific requirements
Schedule B: Guarantees and technical particulars of equipment offered

Item	Sub-clause CP_TSSPEC- 237	Description	Schedule A	Schedule B
26.	18.2	Fire Alarm Control Panel		
26.1.		EMC	CE marked (2004/108/EC)	
26.2.		Loop capacity	127 addresses	
26.3.		Compatibility	All ZP analogue addressable equipment	
26.4.		<u>Power Requirements:</u> Panel type:	(Quiescent at 24 VDC) 2 loop 420mA	
26.5.		Panel alarm:	(Alarm at 24 VDC) 820mA 25% of zones in alarm	
26.6.		Mounting	Surface or recessed	
26.7.		Monitoring	Loop wiring Open and short circuit fault, earth leakage, sensor removed and wrong device type	
26.8.		Switched outputs (standard)	Sounder circuits 2 x dual Fire (common) Fault (common)	
26.9.		Standby batteries: Accommodated inside panel enclosure	2 x 12 volt sealed lead acid - up to 28 Ah	
26.10		Switched I/O	Non loop devices, sounder circuits, relay	

**SPECIFICATION FOR INTERGRATED
SECURITY SYSTEMS**

REFERENCE

REV

CP_TSSPEC_237

1

PAGE

135

172

26.11	Software: Firmware and site configuration programming - Flash memory	Required	
26.12	Communications ports	RS485 and Ethernet	
26.13	Temperature range °C	-5 - +40	
26.14	Humidity range	10% to 90% RH (non-condensing)	
26.15	Environmental	IP30 (indoor installation)	
26.16	Construction: Enclosure - Back box and hinged door - sheet steel.	Required	
26.17	Locally Supported	Yes	

Tender Number: _____

Tenderer's Authorized Signatory: _____
Name in block letters
Signature

Full name of company: _____

**SPECIFICATION FOR INTERGRATED
SECURITY SYSTEMS**

REFERENCE

REV

CP_TSSPEC_237

1

PAGE

136

172

FIRE ALARM CONTROL PANEL

Deviation Schedule

Any deviations offered to this specification shall be listed below with reasons for deviation. In addition, evidence shall be provided that the proposed deviation shall at least be more cost-effective than that specified by City Power.

Item	Sub Clause of CP_TSSPEC_237	Proposed deviation

Tender Number: _____

Tenderer's Authorized Signatory: _____
Name in block letters
Signature

Full name of company: _____

**SPECIFICATION FOR INTERGRATED
SECURITY SYSTEMS**

REFERENCE
CP_TSSPEC_237
PAGE 137

REV
1
172

45. ITEM NO 27 – FIRE DETECTION SENSORS

TECHNICAL SCHEDULES A & B:

Schedule A: Purchaser's specific requirements

Schedule B: Guarantees and technical particulars of equipment offered

Item	Sub-clause CP_TSSPEC- 237	Description	Schedule A	Schedule B
27.	18.3	Fire Detection Sensors		
27.1.		Compliance to the following: SANS50054-5 SANS50054-7	Yes Yes	
27.2.		Smoke element to comply to SANS50054-7and CEA4021	Yes	
27.3.		Heat element to comply to SANS50054-5 Class A1 and A2	Yes	
27.4.		Wiring	2 core loop or spur, PH30 Fire resistant 2-core 1,5mm ² .	
27.5.		Area coverage	Smoke element - 100m ² , subject to local codes	
27.6.		Thermal element	50mm², subject to local codes	
27.7.		Monitoring: Open and short circuit fault sensor removal.	Required	
27.8.		Detection principle: Smoke - photo electric light scatter, heat - thermistor.	Required	
27.9.		Addressing method	7 way DIL switches in head	
27.10		Operating voltage	19.5 to 20.5 volts pulsed address line	
27.11		Current	uA 600 quiescent, 700 alarm	
27.12		Application	Indoor installation	

SPECIFICATION FOR INTERGRATED SECURITY SYSTEMS

REFERENCE

REV

CP_TSSPEC_237

1

PAGE

138

172

27.13	EN60529 rating		IP32
27.14	Temperature range	°C	-10 - +50
27.15	Humidity range	%	20 - 95 RH (non-condensing) (95 RH in all tunnel installations)
27.16	EMC		CE compliant
27.17	Material		Moulded ABS plastic
27.18	Locally Supported		Yes

Tender Number: _____

Tenderer's Authorized Signatory: _____
Name in block letters
Signature

Full name of company: _____

**SPECIFICATION FOR INTERGRATED
SECURITY SYSTEMS**

REFERENCE

REV

CP_TSSPEC_237

1

PAGE

139

172

FIRE DETECTION SENSORS

Deviation Schedule

Any deviations offered to this specification shall be listed below with reasons for deviation. In addition, evidence shall be provided that the proposed deviation shall at least be more cost-effective than that specified by City Power.

Item	Sub Clause of CP_TSSPEC_237	Proposed deviation

Tender Number: _____

Tenderer's Authorized Signatory: _____
Name in block letters
Signature

Full name of company: _____

**SPECIFICATION FOR INTERGRATED
SECURITY SYSTEMS**

REFERENCE
CP_TSSPEC_237
PAGE 140

REV
1
172

46. ITEM NO 28 – FIRE BEAM DETECTORS

TECHNICAL SCHEDULES A & B:

Schedule A: Purchaser's specific requirements
Schedule B: Guarantees and technical particulars of equipment offered

Item	Sub-clause CP_TSSPEC- 237	Description	Schedule A	Schedule B
28.	18.4	Fire Beam Detectors		
28.1.		Supply Voltage:	24 VDC nominal	
28.2.		Imager Current Consumption: <ul style="list-style-type: none"> Nominal (at 24 VDC): 8mA (1 Emitter), 10mA (7 Emitters), Peak (at 24 VDC) during training mode: 31mA 	Required Required	
28.3.		Emitter Current Consumption: <ul style="list-style-type: none"> Wired Version (at 24 VDC): 350µA Std. Power, 800µA High Power, Battery Version (1.0 - 3.2 VDC): OSE-RBA Built-in Battery: -SP Version: 5-year battery life	Required	
28.4.		Alarm Threshold Levels:		
		Low - highest sensitivity / earliest alarm:	20% (0.97 dB)	
		Medium - medium sensitivity:	35% (1.87 dB)	
		High - lowest sensitivity / maximum immunity to nuisance smoke conditions	50% (3.01 dB)	
28.5.		Adjustment Angle:	±60° (horizontal), ±15° (vertical)	
28.6.		Configuration Options: Imager: 45°, Field of View: Horizontal - 38°, Vertical - 19°, Detection Range:	Required	

**SPECIFICATION FOR INTERGRATED
SECURITY SYSTEMS**

REFERENCE

REV

CP_TSSPEC_237

1

PAGE

141

172

28.7.		Operating Conditions temperature	-10°C to 55°C, Humidity: 10 to 95% RH (non-condensing)	
28.8.		Locally Supported	Yes	
		Standard Power: Min: 15m, Max: 60m, High Power: Min: 30m, Max: 120m/100m	Required	

Tender Number: _____

Tenderer's Authorized Signatory: _____

Name in block letters

Signature

Full name of company: _____

**SPECIFICATION FOR INTERGRATED
SECURITY SYSTEMS**

REFERENCE

REV

CP_TSSPEC_237

1

PAGE

142

172

FIRE BEAM DETECTORS

Deviation Schedule

Any deviations offered to this specification shall be listed below with reasons for deviation. In addition, evidence shall be provided that the proposed deviation shall at least be more cost-effective than that specified by City Power.

Item	Sub Clause of CP_TSSPEC_237	Proposed deviation

Tender Number: _____

Tenderer's Authorized Signatory: _____
Name in block letters Signature

Full name of company: _____

**SPECIFICATION FOR INTERGRATED
SECURITY SYSTEMS**

**REFERENCE
CP_TSSPEC_237
PAGE 143**

**REV
1
172**

47. ITEM NO 29 – DIGITAL INPUT CONTROL MODULES

TECHNICAL SCHEDULES A & B:

Schedule A: Purchaser's specific requirements

Schedule B: Guarantees and technical particulars of equipment offered

Item	Sub-clause CP_TSSPEC- 237	Description	Schedule A	Schedule B
29.	19.2	Intrusion IO Card		
29.1.		Primary Power (DC) The ICM is for use in low voltage, power-limited, class 2 circuits only	Required	
29.2.		DC Input	24 VDC ±15%. 350 mA	
29.3.		Environmental		
29.4.		Temperature °C	Operating: 0 - +70	
29.5.		Humidity	0 to 95% RHNC	
29.6.		Approvals	UL 294 and 1076-listed, CE-marked, ROHS compliant	
29.7.		Locally Supported	Yes	

Tender Number: _____

Tenderer's Authorized Signatory: _____
Name in block letters Signature

Full name of company: _____

**SPECIFICATION FOR INTERGRATED
SECURITY SYSTEMS**

REFERENCE

REV

CP_TSSPEC_237

1

PAGE

144

172

DIGITAL INPUT CONTROL MODULES

Deviation Schedule

Any deviations offered to this specification shall be listed below with reasons for deviation. In addition, evidence shall be provided that the proposed deviation shall at least be more cost-effective than that specified by City Power.		
Item	Sub Clause of CP_TSSPEC_237	Proposed deviation

Tender Number: _____

Tenderer's Authorized Signatory: _____
Name in block letters
Signature

Full name of company: _____

**SPECIFICATION FOR INTERGRATED
SECURITY SYSTEMS**

REFERENCE

REV

CP_TSSPEC_237

1

PAGE

147

172

49. ITEM NO 31 – PIR

TECHNICAL SCHEDULES A & B:

Schedule A: Purchaser's specific requirements

Schedule B: Guarantees and technical particulars of equipment offered

Item	Sub-clause CP_TSSPEC- 237	Description	Schedule A	Schedule B
31.	19.5	PIR		
31.1.		Detection Range m	Coverage diameter of 9.3 at 6.3 mounting height	
31.2.		Optics	Fresnel lens	
31.3.		Power supply VDC	9 to 15	
31.4.		Current consumption (nom.) mA	8.7	
31.5.		Alarm relay	<24 VDC, 50mA, NC	
31.6.		Tamper relay	<24 VDC, 50mA, NC	
31.7.		Target speed range	30cm/s to 3m/s	
31.8.		Ambient conditions °C	-10 to +55	
31.9.		Relative humidity (max) %	95	
31.10		IN50131-2-2	Grade 2	
31.11		UL/CUL variant	Available/Required	
31.12		Locally Supported	Yes	

Tender Number: _____

Tenderer's Authorized Signatory: _____
Name in block letters Signature

Full name of company: _____

**SPECIFICATION FOR INTERGRATED
SECURITY SYSTEMS**

REFERENCE

REV

CP_TSSPEC_237

1

PAGE

148

172

PIR

Deviation Schedule

Any deviations offered to this specification shall be listed below with reasons for deviation. In addition, evidence shall be provided that the proposed deviation shall at least be more cost-effective than that specified by City Power.

Item	Sub Clause of CP_TSSPEC_237	Proposed deviation

Tender Number: _____

Tenderer's Authorized Signatory: _____
Name in block letters
Signature

Full name of company: _____

SPECIFICATION FOR INTERGRATED SECURITY SYSTEMS

REFERENCE
CP_TSSPEC_237
 PAGE 149

REV
1
 172

50. ITEM NO 32 – IR BEAMS

TECHNICAL SCHEDULES A & B:

Schedule A: Purchaser's specific requirements
 Schedule B: Guarantees and technical particulars of equipment offered

Item	Sub-clause CP_TSSPEC- 237	Description	Schedule A	Schedule B
32.	19.6	IR Beams		
32.1.		Type:	Photoelectric Detector	
32.2.		Detection Range m	60	
		Features: Quad high power beams with waterproof structure & Tamper function at IP65	Required	
32.3.		Maximum detection range: m	60	
32.4.		Detection method: Quad infrared beam interruption detection.	Required	
32.5.		Interruption time: Variable between ms	50/100/250/500	
32.6.		Power Source: VCD	10.5 - 30	
32.7.		Operating temperature: °C	-25 - +60	
32.8.		Operating humidity (max): %	95	
32.9.		Alignment angle: °	±90 Horizontal, ±10 Vertical	
32.10		Locally Supported:	Yes	

Tender Number: _____

Tenderer's Authorized Signatory: _____
 Name in block letters Signature

Full name of company: _____

**SPECIFICATION FOR INTERGRATED
SECURITY SYSTEMS**

REFERENCE

REV

CP_TSSPEC_237

1

PAGE

150

172

IR BEAMS

Deviation Schedule

Any deviations offered to this specification shall be listed below with reasons for deviation. In addition, evidence shall be provided that the proposed deviation shall at least be more cost-effective than that specified by City Power.

Item	Sub Clause of CP_TSSPEC_237	Proposed deviation

Tender Number: _____

Tenderer's Authorized Signatory: _____
Name in block letters
Signature

Full name of company: _____

51. ITEM NO 33 – ETHERNET SWITCH

TECHNICAL SCHEDULES A & B:

Schedule A: Purchaser's specific requirements

Schedule B: Guarantees and technical particulars of equipment offered

Item	Sub-clause CP_TSSPEC- 237	Description	Schedule A	Schedule B
33.	20.3	Ethernet Switch:		
33.1.		Copper Ports:	24 10/100 Mbps data PoE+	
33.2.		Power: Dual redundant, modular power supplies and three modular fans providing redundancy	Required	
33.3.		PoE: Full IEEE 802.3at (PoE+) with 30W power on all copper ports in 1 rack unit	Required	
33.4.		Protocol: Software support for IPv4 and IPv6 routing, multicast routing, modular quality of service (QoS).	Required	
33.5.		Single universal Cisco IOS® Software image across all license levels, providing an easy upgrade path for software features	Required	
33.6.		Warranty: Enhanced limited lifetime warranty (E- LLW) with next business day (NBD) advance hardware replacement and 90-day access to CSICO Technical Assistance Centre (TAC) support	Required	
33.7.		Network Modules: 4 x Gigabit Ethernet with Small Form- Factor Pluggable (SFP) receptacles	24 PoE+ 435W Required	
33.8.		Environment: Operating Temperature: °C	-40 - 75	
33.9.		Storage Temperature: °C	-40 - 75	
		Humidity: %	Operating: 5 - 95 (Non- condensing)	

**SPECIFICATION FOR INTERGRATED
SECURITY SYSTEMS**

REFERENCE

REV

CP_TSSPEC_237

1

PAGE

153

172

**ETHERNET SWITCH
Deviation Schedule**

Any deviations offered to this specification shall be listed below with reasons for deviation. In addition, evidence shall be provided that the proposed deviation shall at least be more cost-effective than that specified by City Power.

Item	Sub Clause of CP_TSSPEC_237	Proposed deviation

Tender Number: _____

Tenderer's Authorized Signatory: _____
Name in block letters
Signature

Full name of company: _____

52. ITEM NO 34 – DIGITAL AUDIO EQUIPMNET

TECHNICAL SCHEDULES A & B:

Schedule A: Purchaser's specific requirements

Schedule B: Guarantees and technical particulars of equipment offered

Item	Sub-clause CP_TSSPEC- 237	Description	Schedule A	Schedule B
34.	21.2	Digital Audio Equipment		
34.1.		Interfaces: Standard Local Networking, 2 x RJ45	Required	
34.2.		Ethernet interface :TCP/IP, MOD BUS, Vox-Net and 3rd party devices.	Required	
34.3.		Security microphone connection support: 4 X RJ45, PC1 to PC4: MOD BUS, Vox-Net and 3 rd party devices.	Required	
34.4.		Balanced audio with eight outputs.	Required	
34.5.		Two audio outputs for back-up amplifiers.	Required	
34.6.		Inputs	Return 100 Volt lines input from amplifiers.	
34.7.		Outgoing	16 (8+8) 100 Volt lines to the loudspeakers.	
34.8.		Optional inputs	-2 slots for 8 mic /line/ digital AES /EBU audio inputs/outputs	
34.9.		Nine logic inputs	Required	
34.10.		Eight Logic outputs	Required	
34.11.		Security contacts for evacuation and fault reporting and fault-back inputs.	Required	
34.12.		Messages storage :Four hours capacity. Playing up to 48 messages	Required	
34.13.		Locally Supported	Yes	

**SPECIFICATION FOR INTERGRATED
SECURITY SYSTEMS**

REFERENCE	REV
CP_TSSPEC_237	1
PAGE	172

Tender Number: _____

Tenderer's Authorized Signatory: _____
Name in block letters Signature

Full name of company: _____

**SPECIFICATION FOR INTERGRATED
SECURITY SYSTEMS**

REFERENCE

REV

CP_TSSPEC_237

1

PAGE

156

172

DIGITAL AUDIO EQUIPMNET

Deviation Schedule

Any deviations offered to this specification shall be listed below with reasons for deviation. In addition, evidence shall be provided that the proposed deviation shall at least be more cost-effective than that specified by City Power.

Item	Sub Clause of CP_TSSPEC_237	Proposed deviation

Tender Number: _____

Tenderer's Authorized Signatory: _____
Name in block letters
Signature

Full name of company: _____

**SPECIFICATION FOR INTERGRATED
SECURITY SYSTEMS**

REFERENCE REV
CP_TSSPEC_237 **1**
PAGE 158 172

SECURED CALL STATIONS

Deviation Schedule

<p>Any deviations offered to this specification shall be listed below with reasons for deviation. In addition, evidence shall be provided that the proposed deviation shall at least be more cost-effective than that specified by City Power.</p>		
Item	Sub Clause of CP_TSSPEC_237	Proposed deviation

Tender Number: _____

Tenderer's Authorized Signatory: _____
Name in block letters Signature

Full name of company: _____

**SPECIFICATION FOR INTERGRATED
SECURITY SYSTEMS**

REFERENCE

REV

CP_TSSPEC_237

1

PAGE

160

172

INDOOR WALL MOUNTED SPEAKERS

Deviation Schedule

Any deviations offered to this specification shall be listed below with reasons for deviation. In addition, evidence shall be provided that the proposed deviation shall at least be more cost-effective than that specified by City Power.

Item	Sub Clause of CP_TSSPEC_237	Proposed deviation

Tender Number: _____

Tenderer's Authorized Signatory: _____
Name in block letters
Signature

Full name of company: _____

**SPECIFICATION FOR INTERGRATED
SECURITY SYSTEMS**

REFERENCE
CP_TSSPEC_237

REV
1

PAGE **161**

172

55. - ITEM NO 37 – INDOOR CEILING MOUNTED SPEAKERS

TECHNICAL SCHEDULES A & B:

Schedule A: Purchaser's specific requirements

Schedule B: Guarantees and technical particulars of equipment offered

Item	Sub-clause CP_TSSPEC- 237	Description	Schedule A	Schedule B
37.	21.4.2	Indoor Ceiling Mounted Speakers		
37.1.		RMS rated output	6W at 100V	
37.2.		100V Line voltage transformer taps	W 6 & 3	
37.3.		70V Line voltage taps	W 3 & 1.5	
37.4.		Speakers required in housing	" 5	
37.5.		Frequency response	110Hz - 14.5 kHz	
37.6.		Impedance	kΩ 3.3/1.7	
37.7.		Maximum SPL	dB 98	
37.8.		SPL (1W at 1m)	dB 90	
37.9.		Connection inside dome	Black & Red line - ceramic	
37.10		Mounting	Spring clip	
37.11		Locally Supported	Yes	

Tender Number: _____

Tenderer's Authorized Signatory: _____
Name in block letters Signature

Full name of company: _____

**SPECIFICATION FOR INTERGRATED
SECURITY SYSTEMS**

REFERENCE

REV

CP_TSSPEC_237

1

PAGE

162

172

INDOOR CEILING MOUNTED SPEAKERS

Deviation Schedule

Any deviations offered to this specification shall be listed below with reasons for deviation. In addition, evidence shall be provided that the proposed deviation shall at least be more cost-effective than that specified by City Power.

Item	Sub Clause of CP_TSSPEC_237	Proposed deviation

Tender Number: _____

Tenderer's Authorized Signatory: _____
Name in block letters Signature

Full name of company: _____

**SPECIFICATION FOR INTERGRATED
SECURITY SYSTEMS**

REFERENCE

REV

CP_TSSPEC_237

1

PAGE

163

172

56. - ITEM NO 38 – OUTDOOR HORN SPEAKERS

TECHNICAL SCHEDULES A & B:

Schedule A: Purchaser's specific requirements

Schedule B: Guarantees and technical particulars of equipment offered

Item	Sub-clause CP_TSSPEC- 237	Description		Schedule A	Schedule B
38.	21.4.3	Outdoor Horn Speakers			
38.1.		RMS rated power	W	20	
38.2.		100V Line voltage transformer taps	W	2.5, 5, 10 & 20	
38.3.		Transformer Impedance		500Ω, 1kΩ, 2kΩ & 4kΩ	
38.4.		70V Line voltage transformer taps	W	1.25, 2.5, 5 & 10	
38.5.		Effective frequency range		310Hz - 16 kHz	
38.6.		Impedance	Ω	8	
38.7.		SPL @ 4m, 1W, 1 kHz, 1/3 Octave	dB	81	
38.8.		SPL @ 1m, 1W, 1 kHz,	dB	107	
38.9.		SPL @ 4m, full power,	dB	93	
38.10		Dispersion 1 kHz/2kHz		111/62°	
				Horizontal, 148/84° Vertical	
38.11		IP Rating		33	
38.12		Material: Low smoke, zero halogen, UL- 94VO plastic.		Required	
38.13		Locally Supported		Yes	

Tender Number: _____

Tenderer's Authorized Signatory: _____

Name in block letters

Signature

Full name of company: _____

**SPECIFICATION FOR INTERGRATED
SECURITY SYSTEMS**

REFERENCE

REV

CP_TSSPEC_237

1

PAGE

164

172

OUTDOOR HORN SPEAKERS

Deviation Schedule

Any deviations offered to this specification shall be listed below with reasons for deviation. In addition, evidence shall be provided that the proposed deviation shall at least be more cost-effective than that specified by City Power.

Item	Sub Clause of CP_TSSPEC_237	Proposed deviation

Tender Number: _____

Tenderer's Authorized Signatory: _____
Name in block letters
Signature

Full name of company: _____

**SPECIFICATION FOR INTERGRATED
SECURITY SYSTEMS**

REFERENCE

REV

CP_TSSPEC_237

1

PAGE

166

172

39.14	Operating temperature range:	°C	-20 - 70
39.15	Storage temperature range:	°C	-20° - 70
39.16	Relative humidity:	%	Up to 95 not condensing
39.17	Connection: Pluggable screw terminals expansion plug for IP Uplink: shielded RJ 45 modular jacks		Required
39.18	Power supply:		PoE
39.19	Cabling:		Min. CAT 5
39.20	PoE (Power over Ethernet): IEEE 802.3af:		Required
39.21			Class 0 (0.44 W to 12.95 W)
39.22	Protocol:		IoIP-Protocol based on UDP/IP
39.23	Data rate:		10/100 Mbps (Full/Half Duplex)
39.24	Mounting: Flush mount kit and surface mount		Required
39.25	Locally Supported		Yes

Tender Number: _____

Tenderer's Authorized Signatory: _____
Name in block letters Signature

Full name of company: _____

**SPECIFICATION FOR INTERGRATED
SECURITY SYSTEMS**

REFERENCE

REV

CP_TSSPEC_237

1

PAGE

167

172

IP INTERCOM STATION

Deviation Schedule

Any deviations offered to this specification shall be listed below with reasons for deviation. In addition, evidence shall be provided that the proposed deviation shall at least be more cost-effective than that specified by City Power.

Item	Sub Clause of CP_TSSPEC_237	Proposed deviation

Tender Number: _____

Tenderer's Authorized Signatory: _____
Name in block letters
Signature

Full name of company: _____

**SPECIFICATION FOR INTERGRATED
SECURITY SYSTEMS**

REFERENCE
CP_TSSPEC_237
PAGE 168

REV
1
172

58. ITEM NO 40 – VIDEO INTERCOM SYSTEM

TECHNICAL SCHEDULES A & B:

Schedule A: Purchaser's specific requirements
Schedule B: Guarantees and technical particulars of equipment offered

Item	Sub-clause CP_TSSPEC- 237	Description	Schedule A	Schedule B
40.	21.6	Video Intercom		
40.1.		IP rating:	IP 65	
40.2.		Mechanical impact resistance acc. EN 62262:	IK 07	
40.3.		Microphone: Omnidirectional electret microphone for max. 7 m speaking distance.	Required	
40.4.		Loudspeaker:	85 dB/1 W/1 m, 2 x 8 Ω	
40.5.		Input: 3 inputs for floating contacts	Required	
40.6.		Output: 2 relay outputs	Required	
40.7.		Call button:	Single call button	
40.8.		Operating temperature range: °C	-20 - 60	
40.9.		Relative humidity: %	Up to 95 not condensing	
40.10		Power supply: PoE	Required	
40.11		Cabling:	Min. CAT 5	
40.12		PoE (Power over Ethernet): IEEE 802.3af standard	Required	
40.13		Protocol:	IoIP-Protocol based on UDP/IP	
40.14		Mounting: Surface mount kit	WSSH 50V	
40.15		<u>Hybrid Camera</u> General Data: Image sensor: ¼ inch color CMOS sensor Lens*: Focal distance 3.6mm, F2,8, fixed aperture, angle 67.4°	Required	
		Angle adjustable up to 30° horizontally/vertically	Required	

**SPECIFICATION FOR INTERGRATED
SECURITY SYSTEMS**

REFERENCE

REV

CP_TSSPEC_237

1

PAGE

169

172

40.16	IP video stream: Resolution:	320 x 240 or 640 x 480	
	Video format: Motion JPEG (MJPEG)	Required	
	Picture rate: Up to 30 pictures per second Ethernet: 10/100 Mbps, half-/full duplex	Required	
40.17	Locally Supported	Yes	

Tender Number: _____

Tenderer's Authorized Signatory: _____
Name in block letters Signature

Full name of company: _____

**SPECIFICATION FOR INTERGRATED
SECURITY SYSTEMS**

REFERENCE

REV

CP_TSSPEC_237

1

PAGE

170

172

VIDEO INTERCOM SYSTEM

Deviation Schedule

Any deviations offered to this specification shall be listed below with reasons for deviation. In addition, evidence shall be provided that the proposed deviation shall at least be more cost-effective than that specified by City Power.

Item	Sub Clause of CP_TSSPEC_237	Proposed deviation

Tender Number: _____

Tenderer's Authorized Signatory: _____
Name in block letters
Signature

Full name of company: _____

59. ITEM NO 41 – VIDEO WORKSTATION FOR CONDITION MONITORING

TECHNICAL SCHEDULES A & B:

Schedule A: Purchaser's specific requirements

Schedule B: Guarantees and technical particulars of equipment offered

Item	Sub-clause CP_TSSPEC- 237	Description	Schedule A	Schedule B
41.		VIDEO CLIENT PC:		
41.1.		Intel Xeon Processor E5-1620 Quad Core HT, 3.7 GHz Processor.	Required	
41.2.		8 GB DDR3 non-ECC RAM	Required	
41.3.		8 x DVD +/-RW	Required	
41.4.		256 GB 2.5 inch Serial ATA Solid State Drive	Required	
41.5.		4 GB AMD FirePro™ W7000 (4 DP)	Required	
41.6.		Latest Windows Professional 64-bit Operating System	Required	
41.7.		Interfance: RJ45 Ethernet port	Required	
41.8.		USB 3.0 ports - 4 off	Required	
41.9.		RS232 serial port	Required	
41.10		USB keyboard/mouse	Required	
41.11		Resolution:	21" 1920x1080	

Tender Number: _____

Tenderer's Authorized Signatory: _____
Name in block letters
Signature

Full name of company: _____