

**Transnet Rail Infrastructure Manager**

an Operating Division of **TRANSNET SOC LTD**

[hereinafter referred to as **Transnet**]

[Registration No. 1990/000900/30]

REQUEST FOR PROPOSAL [RFP] [GOODS]

FOR THE SUPPLY AND DELIVERY OF OHTE WIRES AS AND WHEN REQUIRED FOR THE EASTERN REGION

FOR A PERIOD OF: TWELVE (12) MONTHS

RFP NUMBER HOAC VAR 57488

ISSUE DATE: 27 MAY 2026

CLOSING DATE: 04 JUNE 2026

CLOSING TIME: 12H00

**BID VALIDITY PERIOD: 180 BUSINESS DAYS FROM CLOSING DATE
(15 FEBRUARY 2027)**

SUBMISSION TO: Transnet e-tender submission portal – see SBD 1 for details

SCHEDULE OF BID DOCUMENTS

Section No	Page
SECTION 1: SBD1 FORM.....	4
SECTION 2: NOTICE TO BIDDERS	6
1 INVITATION TO BID	6
2 FORMAL BRIEFING	7
3 PROPOSAL SUBMISSION	7
4 RFP INSTRUCTIONS.....	8
5 JOINT VENTURES OR CONSORTIUMS.....	8
6 COMMUNICATION (CLARIFICATIONS AND COMPLAINTS)	9
7 CONFIDENTIALITY	9
8 COMPLIANCE	9
9 EMPLOYMENT EQUITY ACT	9
10 DISCLAIMERS.....	9
11 LEGAL REVIEW.....	10
12 SECURITY CLEARANCE.....	10
SECTION 3: BACKGROUND, OVERVIEW AND SCOPE OF REQUIREMENTS.....	12
1 BACKGROUND	12
2 EXECUTIVE OVERVIEW	12
3 SCOPE OF REQUIREMENTS	12
4 GREEN ECONOMY / CARBON FOOTPRINT.....	13
5 GENERAL SUPPLIER OBLIGATIONS	13
6 EVALUATION METHODOLOGY	13
SECTION 4: PRICING AND DELIVERY SCHEDULE	20
1. DISCLOSURE OF CONTRACT INFORMATION	28
2. RETURN OF SURPLUS GOODS	29
3. PRE-PRODUCTION SAMPLES/PROTOTYPES.....	29
4. MANUFACTURERS.....	29
5. INSPECTION DETAILS.....	29
6. IMPORTED CONTENT.....	30
7. EXCHANGE AND REMITTANCE	30
8. EXPORT CREDIT AGENCY SUPPORTED FINANCE.....	31
9. NATIONAL RAILWAY SAFETY REGULATOR ACT.....	31
10. SERVICE LEVELS	31
11. RISK	32
SECTION 5: PROPOSAL FORM AND LIST OF RETURNABLE DOCUMENTS.....	33
SECTION 6: RFQ DECLARATION CERTIFICATE OF ACQUAINTANCE & BREACH OF LAW FORM WITH RFP.....	37
SECTION 7: RFP CLARIFICATION REQUEST FORM	42
SECTION 8 : SPECIFIC GOALS POINTS CLAIM FORM.....	43
SECTION 9: PROTECTION OF PERSONAL INFORMATION.....	49

RFP APPENDICES:

ANNEXURE A: TENDER EVALUATION METHODOLOGY

ANNEXURE B: SPECIFICATION AND DRAWINGS

ANNEXURE C, D, E: LOCAL CONTENT

ANNEXURE F: MASTER AGREEMENT

ANNEXURE G: TRANSNET'S GENERAL BID CONDITIONS

ANNEXURE H: TRANSNET'S SUPPLIER INTEGRITY PACT

ANNEXURE I: NON-DISCLOSURE AGREEMENT

Respondent's Signature

Date & Company Stamp

**RFP FOR THE SUPPLY AND DELIVERY OF OHTE WIRES AS AND WHEN REQUIRED FOR THE EASTERN REGION
FOR A PERIOD OF 12 MONTHS****SECTION 1: SBD1 FORM
PART A - INVITATION TO BID**

YOU ARE HEREBY INVITED TO BID FOR REQUIREMENTS OF TRANSNET FREIGHT RAIL, A DIVISION TRANSNET SOC LTD							
BID NUMBER:	HOAC VAR 57488	ISSUE DATE:	27 MAY 2026	CLOSING DATE:	04 JUNE 2026	CLOSING TIME:	12H00
DESCRIPTION:	SUPPLY AND DELIVERY OF OHTE WIRES AS AND WHEN REQUIRED FOR THE EASTERN REGION FOR A PERIOD OF 12 MONTHS						
BID RESPONSE DOCUMENTS SUBMISSION INSTRUCTIONS							
<i>(please refer to section 2, paragraph 3 for a detailed process on how to upload submissions):</i> https://esupplierportal.transnet.net/							
BIDDING PROCEDURE / TECHNICAL ENQUIRIES MAY BE DIRECTED TO:							
CONTACT PERSON	SOPHIE GOLDSTONE						
TELEPHONE NUMBER	035 906 7662						
FACSIMILE NUMBER	NOT APPLICABLE						
E-MAIL ADDRESS	SOPHIE.GOLDSTONE@TRANSNET.NET						
SUPPLIER INFORMATION							
NAME OF BIDDER							
POSTAL ADDRESS							
STREET ADDRESS							
TELEPHONE NUMBER	CODE			NUMBER			
CELLPHONE NUMBER							
FACSIMILE NUMBER	CODE			NUMBER			
E-MAIL ADDRESS							
VAT REGISTRATION NUMBER							
IT IS A CONDITION OF THIS BID THAT THE TAX MATTERS OF THE SUCCESSFUL RESPONDENTS BE IN ORDER, OR THAT SATISFACTORY ARRANGEMENTS HAVE BEEN MADE WITH SOUTH AFRICAN REVENUE SERVICE (SARS) TO MEET THE RESPONDENTS TAX OBLIGATIONS.							
	TCP PIN		OR	CSD NO			
SUPPLIER COMPLIANCE STATUS	<input type="checkbox"/> Yes <input type="checkbox"/> No		OR	BBEE STATUS LEVEL SWORN AFFIDAVIT			
If Yes, Who was the Certificate issued by?							
AN ACCOUNTING OFFICER AS CONTEMPLATED IN THE CLOSE CORPORATION ACT (CCA) AND NAME THE APPLICABLE IN THE TICK BOX	<input type="checkbox"/>	AN ACCOUNTING OFFICER AS CONTEMPLATED IN THE CLOSE CORPORATION ACT (CCA)					
	<input type="checkbox"/>	A VERIFICATION AGENCY ACCREDITED BY THE SOUTH AFRICAN ACCREDITATION SYSTEM (SANAS)					
	<input type="checkbox"/>	A REGISTERED AUDITOR NAME:					

Respondent's Signature

Date & Company Stamp

[A B-BBEE STATUS LEVEL VERIFICATION CERTIFICATE/ SWORN AFFIDAVIT (FOR EMES & QSEs) MUST BE SUBMITTED FOR PURPOSES OF COMPLIANCE WITH THE B-BBEE ACT]

1 ARE YOU THE ACCREDITED REPRESENTATIVE IN SOUTH AFRICA FOR THE GOODS /SERVICES /WORKS OFFERED?	<input type="checkbox"/> Yes <input type="checkbox"/> No [IF YES ENCLOSE PROOF]	2 ARE YOU A FOREIGN BASED SUPPLIER FOR THE GOODS /SERVICES /WORKS OFFERED?	<input type="checkbox"/> Yes <input type="checkbox"/> No [IF YES, ANSWER QUESTIONNAIRE BELOW]
Signature of the Bidder	Date:

QUESTIONNAIRE TO BIDDING FOREIGN SUPPLIERS

- IS THE BIDDER A RESIDENT OF THE REPUBLIC OF SOUTH AFRICA (RSA)? YES NO
- DOES THE BIDDER HAVE A BRANCH IN THE RSA? YES NO
- DOES THE BIDDER HAVE A PERMANENT ESTABLISHMENT IN THE RSA? YES NO
- DOES THE BIDDER HAVE ANY SOURCE OF INCOME IN THE RSA? YES NO

IF THE ANSWER IS "NO" TO ALL OF THE ABOVE, THEN IT IS NOT A REQUIREMENT TO REGISTER FOR A TAX COMPLIANCE STATUS SYSTEM PIN CODE FROM THE SOUTH AFRICAN REVENUE SERVICE (SARS) AND IF NOT REGISTER AS PER 1.3 BELOW.

**PART B
TERMS AND CONDITIONS FOR BIDDING**

1. TAX COMPLIANCE REQUIREMENTS

- 1.1 BIDDERS MUST ENSURE COMPLIANCE WITH THEIR TAX OBLIGATIONS.
- 1.2 BIDDERS ARE REQUIRED TO SUBMIT THEIR UNIQUE PERSONAL IDENTIFICATION NUMBER (PIN) ISSUED BY SARS TO ENABLE THE ORGAN OF STATE TO VERIFY THE TAXPAYER'S PROFILE AND TAX STATUS.
- 1.3 APPLICATION FOR TAX COMPLIANCE STATUS (TCS) PIN MAY BE MADE VIA E-FILING THROUGH THE SARS WEBSITE WWW.SARS.GOV.ZA.
- 1.4 BIDDERS MAY ALSO SUBMIT A PRINTED TCS CERTIFICATE TOGETHER WITH THE BID.
- 1.5 IN BIDS WHERE UNINCORPORATED CONSORTIA / JOINT VENTURES / SUB-CONTRACTORS ARE INVOLVED, EACH PARTY MUST SUBMIT A SEPARATE TCS CERTIFICATE / PIN / CSD NUMBER.
- 1.6 WHERE NO TCS IS AVAILABLE BUT THE BIDDER IS REGISTERED ON THE CENTRAL SUPPLIER DATABASE (CSD), A CSD NUMBER MUST BE PROVIDED.
- 1.7 RESPONDENTS ARE REQUIRED TO SELF-REGISTER ON NATIONAL TREASURY'S CENTRAL SUPPLIER DATABASE (CSD) WHICH HAS BEEN ESTABLISHED TO CENTRALLY ADMINISTER SUPPLIER INFORMATION FOR ALL ORGANS OF STATE AND FACILITATE THE VERIFICATION OF CERTAIN KEY SUPPLIER INFORMATION. ONLY FOREIGN SUPPLIERS WITH NO LOCAL REGISTERED ENTITY NEED NOT REGISTER ON THE CSD. THE CSD CAN BE ACCESSED AT [HTTPS://SECURE.CSD.GOV.ZA/](https://secure.csd.gov.za/).

NB: FAILURE TO PROVIDE / OR COMPLY WITH ANY OF THE ABOVE PARTICULARS MAY RENDER THE BID INVALID.

SIGNATURE OF BIDDER:

CAPACITY UNDER WHICH THIS BID IS SIGNED:

(Proof of authority must be submitted e.g. company resolution)

DATE: _____

SECTION 2: NOTICE TO BIDDERS**1 INVITATION TO BID**

Responses to this RFP [hereinafter referred to as a **Bid** or a **Proposal**] are requested from persons, companies, close corporations or enterprises [hereinafter referred to as an **entity, Respondent** or **Bidder**].

DESCRIPTION	Supply and delivery of OHTE wires as and when required for the Eastern Region for a period of 12 months [the Goods]
TENDER ADVERT	All Transnet tenders are advertised on the National Treasury's e-Tender Publication Portal and the Transnet website. Should one of these media (i.e. National Treasury's e-Tender Publication Portal or Transnet website) not be available, bidders are advised to check on the other media for advertised tenders.
RFP DOWNLOADING	<p>This RFP may be downloaded directly from National Treasury's e-Tender Publication Portal at www.etenders.gov.za free of charge.</p> <p>To download RFP and Annexures:</p> <ul style="list-style-type: none"> • Click on "Tender Opportunities"; • Select "Advertised Tenders"; • In the "Department" box, select Transnet SOC Ltd. <p>Once the tender has been in the list, click on the "Tender documents" tab and process to download all uploaded documents.</p> <p>The RFP may also be downloaded from the Transnet Portal at https://esupplierportal.transnet.net/ (please use Google Chrome to access Transnet link/site) free of charge (<i>refer to section 2, paragraph 3 below for detailed steps</i>)</p>
COMMUNICATION	<p>Transnet will publish the outcome of this RFP on the National Treasury e-tender portal and Transnet website with 10 days after the award has been finalised. All unsuccessful bidders have a right to request for reasons for their bid not being successful. This requested must be directed to the contact person stated in the SBD 1 form.</p> <p>Any addenda to the RFP or clarifications will be published on the e-tender portal and Transnet website. Bidders are required to check the e-tender portal or Transnet website prior to finalising their bid submissions for any changes or clarifications to the RFP.</p> <p>Transnet will not be held liable if Bidders do not receive the latest information regarding this RFP with the possible consequence of either being disadvantaged or disqualified as a result thereof.</p>
BRIEFING SESSION	<p>No</p> <p>Refer to paragraph 2 for details.</p>
CLOSING DATE	<p>12h00 on 04 JUNE 2026</p> <p>Bidders must ensure that bids are uploaded timeously onto the system. Generally, if a bid is late, it will not be accepted for consideration.</p> <p>Respondents are to submit bid documents by uploading them onto the Transnet system against each tender selected. A Bidder can upload 30mb per upload and multiple uploads are permitted.</p> <p>Bidders should ensure that electronic bid submissions are submitted at least a day before the closing date and bidders should not wait for the last hour before the deadline to submit. This is to enable them to timeously address issues which they may encounter due to internet speed, bandwidth or the size of the number of uploads being submitted. Transnet will not be held liable for any challenges experienced by bidders as a result of their own technical challenges.</p>

VALIDITY PERIOD	<p>180 Business Days from Closing Date (15 FEBRUARY 2027)</p> <p>Bidders are to note that they may be requested to extend the validity period of their bid, at the same terms and conditions, if the internal evaluation process has not been finalised within the validity period. However, once the adjudication body has approved the process and award of the business to the successful bidder(s), the validity of the successful bidder(s)' bid will be deemed to remain valid until a final contract has been concluded.</p> <p>Should a bidder fail to respond to a request for extension of the validity period before it expires, that bidder will be excluded from tender process.</p> <p>With regard to the validity period of next highest ranked bidders, please refer to Section 2, paragraph 10.12</p>
------------------------	---

Any additional information or clarification will be published on the e-Tender portal and Transnet website, if necessary.

2 FORMAL BRIEFING

A formal briefing session will not be held but should Respondents have specific queries they should email these to the Transnet employee(s) indicated in paragraph 6 [Communication] below.

3 PROPOSAL SUBMISSION

Transnet has implemented a new electronic tender submission system, the e-Tender Submission Portal, in line with the overall Transnet digitalization strategy where suppliers can view advertised tenders, register their information, log their intent to respond to bids and upload their bid proposals/responses on to the system.

The Transnet e-Tender Submission Portal can be accessed as follows:

- a) Log on to the Transnet eTenders management platform website/ Portal (<https://esupplierportal.transnet.net/>)
- b) Click on "ADVERTISED TENDERS" to view advertised tenders;
- c) Click on "SIGN IN/REGISTER –to register new bidder information and ensure that all mandatory information is completed) OR;
- d) to sign in if already registered;
- e) Toggle (click to switch) the "Log an Intent" button to submit a bid;
- f) Submit bid documents by uploading them into the system against each tender selected.
- g) Respondents are to submit bid documents by uploading them onto the Transnet system against each tender selected. A Bidder can upload 30mb per upload and multiple uploads are permitted.
- h) Bidders should ensure that electronic bid submissions are submitted at least a day before the closing date and bidders should not wait for the last hour before the deadline to submit. This is to enable them to timeously address issues which they may encounter due to internet speed, bandwidth or the size of the number of uploads being submitted. Transnet will not be held liable for any challenges experienced by bidders as a result of their own technical challenges.
- i) No late submissions will be accepted. The bidder guide can be found on the Transnet Portal <https://esupplierportal.transnet.net/>
- j) Each company must register its own profile using its company details and use the corresponding registered profile to log an intent to bid as well as submitting any bid.
- k) Transnet will not accept a bid or will disqualify a bidder who submits a bid in the Transnet e-tender submission through another bidders'/Company's profile. In other words, each bidder must register the intent to bid and submit its bid through its own profile under the same company name that will eventually bid for the tender. No company shall submit a bid on behalf of another company regardless of the company being a subsidiary or holding company.
- l) In case of a Joint Venture, any of the parties/companies to the Joint Venture may use its registered profile to submit a bid on behalf of the Joint Venture.
- m) A detailed bidder guide can be found on the Transnet Portal <https://esupplierportal.transnet.net/>

3.1 CONDITIONS OF CONTRACT

For this transaction Transnet Rail Infrastructure Manager (TRIM) has identified opportunities of economic transformation and empowerment, TRIM will incorporate a contractual obligation for the winning bidder to execute the identified transformation objectives as a condition of contract.

Each bidder interested in participating in this should be cognisant that it is a condition of contract the winning bidder will be required to contact with Transnet on one or more of the following transformation initiatives by submitting a proposal on how to advance designated groups through:

- **Job creation and preservation**

The proposal must show the total value and number of jobs to be created/preserved for the duration of the contract. These should cover the following designated groups:

Black Youth, Black women, People living with disabilities, People living in rural or underdeveloped areas or townships

4 RFP INSTRUCTIONS

- 4.1 Please sign documents [sign, stamp and date the bottom of each page] before uploading them on the system. The person or persons signing the submission must be legally authorised by the respondent to do so.
- 4.2 **All returnable documents tabled in the Proposal Form [Section 5] must be returned with proposals.**
- 4.3 Unless otherwise expressly stated, all Proposals furnished pursuant to this RFP shall be deemed to be offers. Any exceptions to this statement must be clearly and specifically indicated.
- 4.4 Any additional conditions must be embodied in an accompanying letter. Subject only to clause 15 [Alterations made by the Respondent to Bid Prices] of the General Bid Conditions, paragraph 12 below (Legal Review) and Section 6 of the RFP, alterations, additions or deletions must not be made by the Respondent to the actual RFP documents.

5 JOINT VENTURES OR CONSORTIUMS

Respondents who would wish to respond to this RFP as a Joint Venture [**JV**] or consortium with B-BBEE entities, must state their intention to do so in their RFP submission. Such Respondents must also submit a signed JV or consortium agreement between the parties clearly stating the percentage [%] split of business and the associated responsibilities of each party. If at the time of the bid submission such a JV or consortium agreement has not been concluded, the partners must submit confirmation in writing of their intention to enter into a JV or consortium agreement should they be awarded business by Transnet through this RFP process. This written confirmation must clearly indicate the percentage [%] split of business and the responsibilities of each party. In such cases, award of business will only take place once a signed copy of a JV or consortium agreement is submitted to Transnet.

- Respondents are to note that for the purpose of Evaluation, a JV will be evaluated based on one consolidated B-BBEE score card (a consolidated B-BBEE Status Level verification certificate) Preference points will be awarded to

a bidder for attaining the specific goals requirements in accordance with the table indicated in Table 3.2 of the specific goals Claim Form.

6 COMMUNICATION (CLARIFICATIONS AND COMPLAINTS)

- 6.1 For specific clarification relating to this RFP, an RFP Clarification Request Form should be submitted to [**Sophie Goldstone – Sophie.Goldstone@transnet.net**] before **12h00 on 02 JUNE 2026**, substantially in the form set out in Section 8 hereto. In the interest of fairness and transparency, Transnet's response to such a query will be published on the e-tender portal and Transnet website.
- 6.2 Specific complaints relating to this RFP before or after the closing date should be formally submitted by emailing to groupscmcomplaints@transnet.net. Once the complaint has been submitted, the Transnet SCM Complaints office will acknowledge your complaint and send you a complaint form for completion.
- 6.3 After the closing date of the RFP, a Respondent may only communicate with the DBAC Secretariat [**Prudence Nkabinde**], at telephone number **011 584 0821**, email prudence.nkabinde@transnet.net on any matter relating to its RFP Proposal.
- 6.4 Respondents are to note that changes to its submission will not be considered after the closing date.
- 6.5 It is prohibited for Respondents to attempt, either directly or indirectly, to canvass any officer or employee of Transnet in respect of this RFP between the closing date and the date of the award of the business.
- 6.6 Respondents found to be in collusion with one another will be automatically disqualified and restricted from doing business with organs of state for a specified period.
- 6.7 Transnet will publish the outcome of this RFP in the National Treasury e-tender portal and Transnet website with 10 days after the award has been finalised. Respondents are required to check the National Treasury e-tender Portal and Transnet website for the results of the tender process. All unsuccessful bidders have a right to request Transnet to furnish reasons for their bid not being successful. This requested must be directed to the contact person stated in the SBD 1 form

7 CONFIDENTIALITY

All information related to this RFP is to be treated with strict confidence. In this regard Respondents are required to certify that they have acquainted themselves with the Non-Disclosure Agreement. All information related to a subsequent contract, both during and after completion thereof, will be treated with strict confidence. Should the need however arise to divulge any information related to this RFP or the subsequent contract, written approval must be obtained from Transnet.

8 COMPLIANCE

The successful Respondent [hereinafter referred to as the **Supplier**] shall be in full and complete compliance with any and all applicable laws and regulations.

9 EMPLOYMENT EQUITY ACT

Respondents must comply with the requirements of the Employment Equity Act 55 of 1998 applicable to it including (but not limited to) Section 53 of the Employment Equity Act.

10 DISCLAIMERS

Respondents are hereby advised that Transnet is not committed to any course of action as a result of its issuance of this RFP and/or its receipt of Proposals. In particular, please note that Transnet reserves the right to:

- 10.1 modify the RFP's Goods/Services;

- 10.2 award a contract in connection with this Proposal at any time after the RFP's closing date;
- 10.3 award a contract for only a portion of the proposed Goods/Services which are reflected in the scope of this RFP;
- 10.4 split the award of the contract between more than one Supplier/Service provider, as may be explicitly articulated in the conditions or objective criteria to this RFP;
- 10.5 cancel the bid process;
- 10.6 validate any information submitted by Respondents in response to this bid. This would include, but is not limited to, requesting the Respondents to provide supporting evidence. By submitting a bid, Respondents hereby irrevocably grant the necessary consent to Transnet to do so;
- 10.7 request audited financial statements or other documentation for the purposes of a due diligence exercise;
- 10.8 not accept any changes or purported changes by the Respondent to the bid rates after the closing date and/or after the award of the business, unless the contract specifically provided for it;
- 10.9 to cancel the contract and/request that National Treasury place the Respondent on its Database of Restricted Suppliers for a period not exceeding 10 years, on the basis that a contract was awarded on the strength of incorrect information furnished by the Respondent or on any other basis recognised in law;
- 10.10 to award the business to the next ranked bidder, provided that he/she is still prepared to provide the required Goods at the quoted price, should the preferred bidder fail to sign or commence with the contract within a reasonable period after being requested to do so. Under such circumstances, the validity of the bids of the next ranked bidder(s) will be deemed to remain valid, irrespective of whether the outcome of the tender has been published the outcome of the bid process on the National Treasury e-tender Portal and Transnet website. Bidders may therefore be requested to advise whether they would still be prepared to provide the required Goods at their quoted price.
- 10.11 A bidder may be requested to furnish further information relating to its Environmental, Social and Governance (ESG) standing at any stage of the procurement or contracting process. This information may not be used for purposes of evaluation and/or disqualify bidder but may be use for purpose of record and analysis of ESG compliance.

Note that Transnet will not reimburse any Respondent for any preparatory costs or other work performed in connection with its Proposal, whether or not the Respondent is awarded a contract.

11 LEGAL REVIEW

A Proposal submitted by a Respondent will be subjected to review and acceptance or rejection of its proposed contractual terms and conditions by Transnet's Legal Counsel, prior to consideration for an award of business. A material deviation from the Standard terms or conditions could result in disqualification.

12 SECURITY CLEARANCE

Acceptance of this bid could be subject to the condition that the Successful Respondent, its personnel providing the Goods/Services and its subcontractor(s) must obtain security clearance from the appropriate authorities to the level of **CONFIDENTIAL/ SECRET/TOP SECRET**. Obtaining the required clearance is the responsibility of the Successful Respondent. Acceptance of the bid is also subject to the condition that the Successful Respondent will implement all such security measures as the safe performance of the contract may require.

TRANSNET URGES ITS CLIENTS, SUPPLIERS AND THE GENERAL PUBLIC TO REPORT ANY FRAUD OR CORRUPTION TO

IF YOU DON'T REPORT IT, YOU SUPPORT IT!



Email: Transnet.Reportit@outlook.com

Toll free: 0800 003 056

SMS:0637867403

Please Call Me number: *120*0637867403

Website: <https://whistleblowersoftware.com/secure/Transnet>

SECTION 3: BACKGROUND, OVERVIEW AND SCOPE OF REQUIREMENTS

1 BACKGROUND

Transnet Rail Infrastructure Manager (TRIM) is one of the biggest consumers of Overhead Track Equipment (OHTE) wires in the country. The wires are used in the maintenance refurbishment and de-coppering of OHTE. TRIM depots rely on the OHTE wires to ensure that the electrical infrastructure is maintained according to maintenance standards. The OHTE wire requirements are loaded on the SAP PM system by the depots across the Eastern Region for the two different traction supplies namely 3kV DC and 25kV AC including the transmission lines (2.2 kV AC, 6.6 kV and 11 kV AC). Some of the major wires required by the depots are Deer wire, Tiger wire, and Copper Magnesium wire

The Eastern Region has planned to initiate an as and when procurement event for OHTE wires for 12 months. This is to ensure execution of key projects during the 2025/2026 FY including two Shutdowns planned for the North Corridor and one shutdown planned for the Northeast Corridor. The wires are in high demand due to low stock levels and interventions undertaken by depots to reduce incidents by improving the condition of the infrastructure, and to install wires which are not prone to theft

2 EXECUTIVE OVERVIEW

Whereas Transnet is seeking a partner(s) to provide solutions for its **OHTE WIRES** regionally, it also seeks to improve its current processes for providing these Goods to its end user community throughout its locations.

The selected Supplier(s) must share in the mission and business objectives of Transnet. These mutual goals will be met by meeting contractual requirements and new challenges in an environment of teamwork, joint participation, flexibility, innovation and open communications. In this spirit of partnership, Transnet and its Supplier(s) will study the current ways they do business to enhance current practices and support processes and systems. Such a partnership will allow Transnet to reach higher levels of quality, service and profitability.

Specifically, Transnet seeks to benefit from this partnership in the following ways:

- 2.1 Transnet must receive reduced cost of acquisition and improved service benefits resulting from the Supplier's economies of scale and streamlined service processes.
- 2.2 Transnet must achieve appropriate availability that meets user needs while reducing costs for both Transnet and the chosen Supplier(s).
- 2.3 Transnet must receive proactive improvements from the Supplier with respect to supply of Goods and related processes.
- 2.4 Transnet's overall competitive advantage must be strengthened by the chosen Supplier's leading-edge technology and service delivery systems.
- 2.5 Transnet end users must be able to rely on the chosen Supplier's personnel for service enquiries, recommendations and substitutions.
- 2.6 Transnet must reduce costs by streamlining its acquisition of Goods, including managed service processes on a Group basis.

3 SCOPE OF REQUIREMENTS

- 3.1 Supply and deliver railway OHTE WIRES (Overhead Track Equipment) material as per the supplied material descriptions, drawings, and specifications.
- 3.2 Refer to Annexure B for Specifications and Drawings.

4 GREEN ECONOMY / CARBON FOOTPRINT

Transnet wishes to have an understanding of your company’s position with regard to environmental commitments, including key environmental characteristics such as waste disposal, recycling and energy conservation. *Please submit details of your entity’s policies in this regard.*

5 GENERAL SUPPLIER OBLIGATIONS

- 5.1 The Supplier(s) shall be fully responsible to Transnet for the acts and omissions of persons directly or indirectly employed by them.
- 5.2 The Supplier(s) must comply with the requirements stated in this RFP.

6 EVALUATION METHODOLOGY

Transnet will utilise the following methodology and criteria in selecting a preferred Supplier:

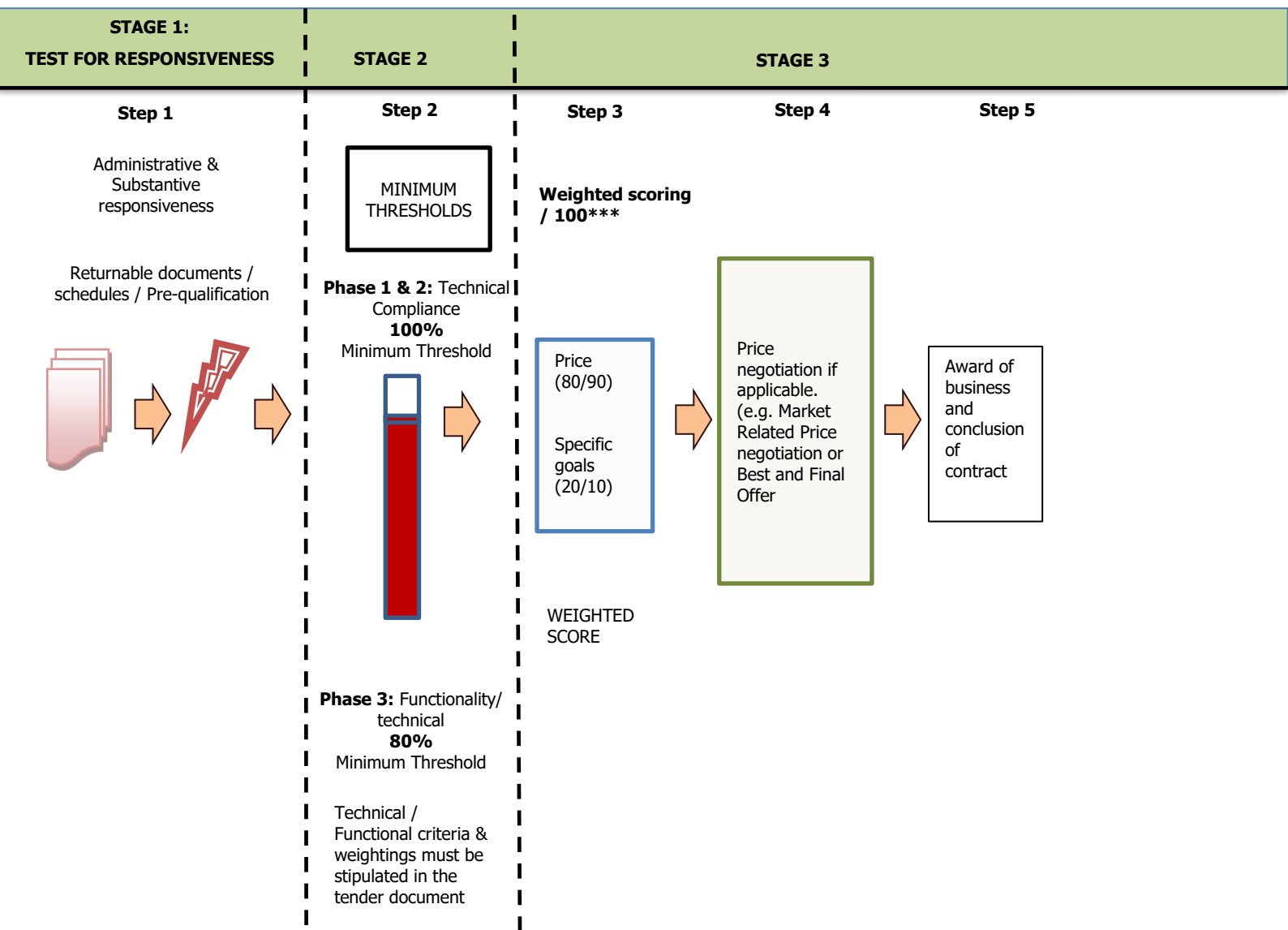

NB: Evaluation of the various stages will normally take place in a sequential manner. However, in order to expedite the process, Transnet reserves the right to conduct the different steps of the evaluation process in parallel. In such instances the evaluation of bidders at any given stage must not be interpreted to mean that bidders have necessarily passed any previous stage(s).

6.1 STEP ONE: Test for Administrative and Substantive Responsiveness

The test for administrative and Substantive responsiveness will include the following:

Administrative & Substantive responsiveness check	RFP Reference
<ul style="list-style-type: none"> Whether the Bid has been lodged on time 	<i>Section 1 paragraph 3</i>
<ul style="list-style-type: none"> Whether all Returnable Documents and/or schedules [where applicable] were completed and returned by the closing date and time 	<i>Section 5</i>
<ul style="list-style-type: none"> Verify the validity of all returnable documents 	<i>Section 5</i>
<ul style="list-style-type: none"> Verify if the Bid document has been duly signed by the authorised respondent 	<i>All sections</i>
<ul style="list-style-type: none"> Whether any general and legislation qualification criteria set by Transnet, have been met 	<i>All sections</i>
<ul style="list-style-type: none"> Whether the Bid contains a priced offer 	<i>Section 4 - Quotation Form</i>
<ul style="list-style-type: none"> Whether the Bid materially complies with the scope and/or specification given 	<i>All Sections</i>

The test for administrative & Substantive responsiveness [Step One] must be passed for a Respondent's Proposal to progress to Step Two for further pre-qualification

6.2 STEP TWO: Technical Compliance Threshold 100% (Phase 1)

<p>Memorandum of Understanding /Manufacturer Confirmation letter</p> <p>Bidders to submit MOUs or Authorization letters of OEM confirmation that fully complies with the substantive response notes.</p> <ol style="list-style-type: none"> If the bidder is not an OEM/Manufacturer, they shall submit a Memorandum of Understanding (MOU)/Authorization letter with the OEM/Manufacturer. <ul style="list-style-type: none"> Memorandum of Understanding/Authorization letter must contain the following: <ul style="list-style-type: none"> ➢ The MOU/approval/authorizationshall be on the OEM's/Manufacturer's official letter head. ➢ It shall state the bidder's company name. ➢ It shall quote the RFP number. ➢ It shall be dated. ➢ It shall be signed by both the manufacturer and the bidder. ➢ It shall state the items of material in which will be manufactured. <p style="text-align: center;">OR</p> If the bidder is the OEM for the material, they shall submit an OEM/Manufacturer's confirmation letter, which clearly states the items they are the OEM of. <ul style="list-style-type: none"> Confirmation letter must contain: <ul style="list-style-type: none"> ➢ The confirmation letter shall be on the manufacturer's officialletterhead. 	<p>Scoring guidelines:</p> <p>The listed criterion under technical compliance will be scored on a 100% or 0% basis and Respondents needs to achieve 100% compliance on the criterions in order to pass the overall technical compliance threshold of 100%</p> <p><u>Note:</u></p> <p>0% = MoU/Authorisations/OEM Confirmation letter does not comply fully</p> <p>100% = MOU/Authorizations letter/OEM/Manufacturer's confirmation letter fully complies</p>
---	---

<ul style="list-style-type: none"> ➤ It shall quote the RFP number. ➤ It shall be dated by the manufacturer. ➤ It shall confirm that the bidder is the manufacturer of the items. ➤ It shall state the items to be supplied. ➤ It shall be signed by the manufacturer. <p>Bidders who do not submit the MOU/Authorization/Confirmation letter shall be disqualified for the items they did not submit for</p> <ul style="list-style-type: none"> - Note: If Original Equipment Manufacturers (OEMs) intend to bid, they will not be allowed to issue Memorandum of Understandings (MOUs). 	
---	--

The minimum threshold for technical compliance [Step TWO – Phase 1] must be met for a Respondent’s Proposal to progress to Step TWO – Phase 2 for evaluation

6.3 STEP TWO: Technical Compliance Threshold 100% (Phase 2)

<p>1.1 Previous experience of similar work experience and specifications provided from the previous 5 years (60 Months).</p> <p>Previous experience of similar work experience and specifications provided from the previous 5 years (60 Months).</p> <ul style="list-style-type: none"> - Inspection certificates: Should be signed or authorized by a member of the Quality Assurance Team, dated, items’ descriptions clearly indicated. - Delivery notes: Should be stamped or signed, dated, items’ descriptions clearly indicated. - Invoices: Should be signed, dated, items’ descriptions clearly indicated. <p>Transnet reserve the right to verify documents submitted</p> <p>Both Inspection certificate (1), and Delivery note (1) or Invoice (1) Submitted)</p> <p>* The evaluation will be conducted per group of Wires</p>	<p><u>Scoring guidelines:</u></p> <p>The listed criterion under technical compliance will be scored on a 100% or 0% basis and Respondents needs to achieve 100% compliance on the criterions in order to pass the overall technical compliance threshold of 100%. The proof of experience must comply with all the stipulated criteria, if it does not comply with the stipulated criteria it will result in score of 0.</p> <p><u>Note:</u></p> <p>0% = No Inspection certificate submitted, Neither Delivery Note or Invoice submitted, none of the documents submitted or proof submitted is outside the required period of 5 years (60 Months) proof submitted does not comply with the stipulated criteria.</p> <p>100% = Bidders to submit proof of testing completed/Inspection certificate, and Delivery note or Invoice for the previous 5 years (60 Months)</p>
---	--

The minimum threshold for technical compliance [Step TWO – Phase 2] must be met for a Respondent’s Proposal to progress to Step TWO – Phase 3 for evaluation

6.4 **STEP TWO: Minimum Threshold 80% for Technical Criteria (Phase 3)**

The test for the Technical and Functional threshold will include the following:

Technical Evaluation Criteria	Points Weightings	Scoring guideline
<p>1.1 Technical compliance to drawings and specifications as provided.</p> <p><u>Evidence required substantiating responses:</u></p> <ol style="list-style-type: none"> Bidder to submit stamped or signed Transnet drawings or specifications proving compliance to given drawings or specifications, SANS and other standards in the item descriptions. <p>Where there are no Transnet drawings or specification bidders to submit the following;</p> <ol style="list-style-type: none"> Bidder to submit drawings, or specifications from OEM/Manufacturer, proving compliance to given drawings, specifications, SANS and other standards in the item descriptions. <p>* The evaluation will be conducted per Category of conductors listed below:</p> <ul style="list-style-type: none"> -Category A (Phase and earth wires) -Category B (Bonding Wire) -Category C (Droppers Wire and Stay Wire) -Category D (Jumper and return wires) -Category E (Feeder wires) -Category F (Catenary wires) -Category G (Contact wires) 	<p>25%</p>	<p>1 point 25% = All drawings in the category comply with the given drawings, specifications, and standards</p> <p>0 points 0% = One or more drawings for items do not comply with the given drawings, specifications and standards</p>
<p>1.2 Proof of Valid ISO 9001 accreditation(s) or an ISO Quality plan(s) of the manufacturing facility/facilities that will be manufacturing the items offered by the bidder. The ISO Quality plan must consist of the following 4 stages:</p> <p>Bidder to provide Valid ISO9001 Certification or ISO Quality Plan</p> <p>(a) The stages of inspection of material from raw material to final product. (Stage 1)</p> <p>(b) Quality assurance plan/Checklist before the material can proceed to the next stage of production (manufacturing) and who approves the final product. (Stage 2)</p> <p>(c) How the material is certified to proceed to the next stage of production. (Stage 3)</p> <p>(d) Any internal test certificates applicable to the material throughout production stages and test certificates for final product. (Stage 4)</p> <p><u>Evidence required substantiating responses:</u></p> <p>Bidder to provide Valid ISO9001 Certification or ISO Quality Plan.</p>	<p>50%</p>	<p>4 points (50%) = Valid ISO9001 certificate or an ISO Quality Plan consists of all 4 stages</p> <p>3 points (37.5%) = ISO Quality Plan consisting of 3 of the 4 stages.</p> <p>2 points (25%) = ISO Quality Plan consisting of 2 of the 4 stages.</p> <p>1 point (12.5%) = ISO Quality Plan consisting of 1 of the 4 stages.</p> <p>0 points = No Quality Plan or Valid ISO certificate Submitted.</p>

Technical Evaluation Criteria	Points Weightings	Scoring guideline
<p>ISO 9001 certification should be issued by accredited certification bodies from the country of issue. Transnet reserve the right to verify the ISO accreditation.</p> <p>For non-OEM bidders, the quality plan(s) or ISO9001 certification(s) shall be for each of the OEM(s)/Manufacturer(s) that provided the MOU(s)/Authorization/Confirmation letter(s). If a quality plan/ISO9001 certification is submitted with no accompanying MOU/Authorization/Confirmation letter, that quality plan/ISO 9001 shall not be evaluated</p> <p>The OEM bidders who own multiple manufacturing facilities that will be manufacturing the items must provide the quality plans or ISO 9001 certifications for each of the OEM(s)/Manufacturer(s) that provided the Confirmation Letter(s), for the facilities that will be manufacturing the material.</p> <p>* The evaluation will be conducted per group of conductors.</p>		
<p>1.3. How long does it take to supply and deliver to Transnet once purchase order has been placed? (1 Week = 5 Business Days)</p> <ul style="list-style-type: none"> The evaluation of the delivery schedule will be based on the delivery of at least 80% of the quantities required per group <u>Evidence required substantiating responses:</u> <p>Bidder to submit a delivery schedule letter. The delivery letter must contain the following:</p> <ul style="list-style-type: none"> The letter shall be on the Bidder’s official letter head. It shall state the bidder’s company name. It shall quote the RFP number. It shall be dated. It shall be signed by the bidder. It should clearly state the delivery lead time of items to be supplied per group. <p>* The evaluation will be conducted per group of conductors.</p>	<p>25%</p>	<p>≤ 8 Weeks 4 points (25%) > 8 ≤ 10 Weeks 3 points (18.75%) > 10 ≤ 12 Weeks 2 points (12.5%) > 12 ≤ 14 Weeks 1 point (6.25%) > 14 Weeks 0 points (0%)</p> <p>No delivery schedule letter supplied or the letter does not meet the six listed requirements 0 points (0%)</p>
<p>Total Weighting:</p>	<p>100</p>	
<p>Minimum qualifying score required:</p>	<p>80%</p>	

***The functional evaluations will be conducted per group of components.**

Respondents must complete and submit ANNEXURE A **which include a Technical Questionnaire**. A Respondent’s compliance with the minimum functionality/technical threshold will be measured by their responses to ANNEXURE A.

Respondents are to note that Transnet will round off final technical scores to the nearest 2 (two) decimal places for the purposes of determining whether the technical threshold has been met.

The minimum threshold for technical/functionality [Step Two] must be met or exceeded for a Respondent’s Proposal to progress to Step Three for final evaluation

a. STEP THREE: Evaluation and Final Weighted Scoring

a) **Price Criteria** [Weighted score 80/90 points]:

Evaluation Criteria	RFP Reference
• Commercial offer	Section 4

Transnet will utilise the following formula in its evaluation of Price:

A maximum of 80 or 90 points is allocated for price on the following basis.

$$PS = 80 \left(1 - \frac{Pt - Pmin}{Pmin} \right) \text{ OR } PS = 90 \left(1 - \frac{Pt - Pmin}{Pmin} \right)$$

Where:

- Ps* = Score for the Bid under consideration
- Pt* = Price of Bid under consideration
- Pmin* = Price of lowest acceptable Bid

b) **Specific Goals** [Weighted score 20 or 10 point]

- Specific goals claim form.
- Preference points will be awarded to a bidder for attaining the specific goals requirements in accordance with the table indicated in Section 9 Table 3.2 of the specific goals Claim Form.

SUMMARY: Applicable Thresholds and Final Evaluated Weightings

Thresholds	Minimum Threshold
Technical / functionality	80%

Evaluation Criteria	Final Weighted Scores
Price	80/90
Specific goals - Scorecard	20/10
TOTAL SCORE:	100

Note: Either the 80/20 or 90/10 preference point system will apply. The lowest acceptable bid will determine the preference point system per Category of conductors Schedule.

b. STEP FOUR: Post Tender Negotiations (if applicable)

- Respondents are to note that Transnet may not award a contract if the price offered is not market-related. In this regard, Transnet reserves the right to engage in PTN with the view to achieving a market-related price or to cancel the tender. Negotiations will be done in a sequential manner i.e.:
 - first negotiate with the highest ranked bidder or cancel the bid, should such negotiations fail,
 - negotiate with the 2nd and 3rd ranked bidders (if required) in a sequential manner.
- In the event of any Respondent being notified of such short-listed/preferred bidder status, his/her bid, as well as any subsequent negotiated best and final offers (BAFO), will automatically be deemed to remain valid during the negotiation period and until the ultimate award of business.
- Should Transnet conduct post tender negotiations, Respondents will be requested to provide their best and final offers to Transnet based on such negotiations. Where a market related price has been achieved through negotiation, the contract will be awarded to the successful Respondent(s).

c. STEP FIVE: Award of business and conclusion of contract

- Immediately after approval to award the contract has been received, the successful bidder(s) will be informed of the acceptance of his/their Bid by way of a Letter of Award. Thereafter the final contract will be concluded with the successful Respondent(s).
- A final contract will be concluded and entered into with the successful Bidder at the acceptance of a letter of award by the Respondent.

SECTION 4: PRICING AND DELIVERY SCHEDULE*Respondents are required to complete the table below:*

Category A (Phase and earth wires)							
Item No	Material Number	Description	Unit	Quantity	Drawing /Specification	Unit rate	Total delivered Price of Item
SCS warehouse in Krugersdorp							
1	54039916	WIRE, ELECTRICAL; TYPE: EARTH, CONDUCTOR DIAMETER: 160 MM2, INSULATION COLOR: NONE, CONDUCTOR MATERIAL: ALUMINIUM HARD DRAWN, PACKAGE TYPE: WOOD DRUM 2 KM; SPECIFICATION: SANS182 PART2, 0; SABS182 PART2; USED ON OHTE; CODE NAME: HORNET; STRAND 19/3.25 MM	M	26000	SANS 182-2		
2	54012945	WIRE, ELECTRICAL; TYPE: PHASE, CONDUCTOR DIAMETER: 50 MM2, INSULATION COLOR: NONE, DIMENSIONS: LG 2 KM, CONDUCTOR MATERIAL: ALUMINIUM, PACKAGE TYPE: REEL, WOOD; SPECIFICATION: SANS182 PART3, LA; MATERIAL NUMBER 054012945; USED ON OHTE; STEEL REINFORCED; CODE NAME: RABBIT	M	9400	SANS182 PART3		
Total Price, exclusive of VAT:							
VAT 15% (if applicable)							
Unconditional Discount(s)							
Total Inclusive of VAT (where applicable)							

Respondent's Signature

Date & Company Stamp

Category B (Bonding Wire)							
Item No	Material Number	Description	Unit	Quantity	Drawing /Specification	Unit rate	Total delivered Price of Item
SCS warehouse in Krugersdorp							
1	54019365	WIRE, ELECTRICAL; TYPE: BONDING, CONDUCTOR DIAMETER: 97 MM2, INSULATION COLOR: BLACK, POTENTIAL RATING: 25 KV, OVERALL DIAMETER: 13 MM, CONDUCTOR MATERIAL: STEEL, CONDUCTOR FINISH: GALVANIZED, SPECIAL FEATURES: INSULATION POLYVINYL CHLORIDE/SHEATHED, PACKAGE TYPE: REEL; SPECIFICATION: SANS182 PART 5, LASANS1507 PART 3, LA; MATERIAL NUMBER 54019365, STRANDED GALVANIZED STEEL WIRE STRANDING 49/1.6MM	M	19000	SANS 182-5/SANS 1507-3		
Total Price, exclusive of VAT:							
VAT 15% (if applicable)							
Unconditional Discount(s)							
Total Inclusive of VAT (where applicable)							

 Respondent's Signature

 Date & Company Stamp

Category C (Dropper Wire and Stay Wire)							
Item No	Material Number	Description	Unit	Quantity	Drawing /Specification	Unit rate	Total delivered Price of Item
SCS warehouse in Krugersdorp							
1	54039888	"WIRE; TYPE: DROPPER, DIAMETER: 4 MM, MATERIAL: STAINLESS STEEL, STRUCTURE: SOLID; SPECIFICATION: AISI GRADE 304 SOFT, LA; PACKAGE TYPE: COIL 50 KG, THE WIRE COIL MUST HAVE A DIAMETER OF 500 MM USED ON OHTE"	KG	2240	AISI GRADE 304		
2	54012868	WIRE, ELECTRICAL; TYPE: STAY, CONDUCTOR DIAMETER: 12.2 MM2, INSULATION COLOR: NONE, DIMENSIONS: LG 300 M, CONDUCTOR MATERIAL: STEEL, CONDUCTOR FINISH: GALVANIZED, PACKAGE TYPE: REEL, WOOD; SPECIFICATION: SANS182 PART5, 0; USED ON OHTE; QUALITY: 700MPA; TENSILE STRENGTH: 61.57KN ,CONDUCTOR SIZE 12-12.2 MM2	M	4200	SANS182 PART5		
3	54012881	WIRE, ELECTRICAL; TYPE: STAY, CONDUCTOR DIAMETER: 20.4 MM2, INSULATION COLOR: NONE, DIMENSIONS: LG 500 M, CONDUCTOR MATERIAL: STEEL, INSULATION MATERIAL: NON INSULATED, CONDUCTOR FINISH: GALVANIZED, PACKAGE TYPE: REEL, WOOD; USED ON OHTE; SPECIFICATION: SANS182 PART5	M	1000	SANS182 PART5		
Total Price, exclusive of VAT:							
VAT 15% (if applicable)							
Unconditional Discount(s)							
Total Inclusive of VAT (where applicable)							

Respondent's Signature

Date & Company Stamp

Category D (Jumper and return wires)							
Item No	Material Number	Description	Unit	Quantity	Drawing /Specification	Unit rate	Total delivered Price of Item
SCS warehouse in Krugersdorp							
1	54013016	WIRE, ELECTRICAL; TYPE: FEEDER, CONDUCTOR DIAMETER: 800 MM2, INSULATION COLOR: NONE, DIMENSIONS: 1 KM, CONDUCTOR MATERIAL: ALUMINIUM HARD DRAWN, PACKAGE TYPE: REEL, WOOD; SPECIFICATION: SANS182 PART2, 0; USED ON OHTE; CODE NAME: BULL; STRAND 61/4.25 MM	M	20000	SANS 182-2		
2	54039459	WIRE, ELECTRICAL; TYPE: RETURN CONDUCTOR, CONDUCTOR DIAMETER: 250 MM2, INSULATION COLOR: NONE, DIMENSIONS: LG 2 KM, CONDUCTOR MATERIAL: ALUMINIUM HARD DRAWN, PACKAGE TYPE: REEL, WOOD; SPECIFICATION: SANS182 PART2, 0; ITEM USED ON OHTE; CODE NAME: COCKROACH; STRAND 19/4.22 MM	M	12000	SANS182 PART2		
Total Price, exclusive of VAT:							
VAT 15% (if applicable)							
Unconditional Discount(s)							
Total Inclusive of VAT (where applicable)							

 Respondent's Signature

 Date & Company Stamp

Category E (Feeder wires)							
Item No	Material Number	Description	Unit	Quantity	Drawing /Specification	Unit rate	Total delivered Price of Item
SCS warehouse in Krugersdorp							
1	54033307	WIRE, ELECTRICAL; TYPE: FEEDER, CONDUCTOR DIAMETER: 800 MM2, INSULATION COLOR: NONE, POTENTIAL RATING: 25 KV, DIMENSIONS: LG 1 KM, CONDUCTOR MATERIAL: ALUMINIUM HARD DRAWN, INSULATION MATERIAL: NONE, PACKAGE TYPE: REEL, WOOD; SPECIFICATION: SANS182 PART 3, LA; ACSR; USED ON OHTE; STEELREINFORCED; CODE NAME; LAPWING; STRAND 45/4.77 MM ALUMINIUM + 7/3.18 MM STEEL	M	3000	SANS 182-3		
2	54112442	WIRE, ELECTRICAL; TYPE: JUMPER, ALL ALUMINUM CONDUCTOR, CONDUCTOR DIAMETER: 160 MM2, INSULATION COLOR: NONE, DIMENSIONS: LG 500 M, CONDUCTOR MATERIAL: ALUMINIUM, INSULATION MATERIAL: NONE, PACKAGE TYPE: REEL, WOOD; SPECIFICATION: BBH 2161, LA	M	48500	BBH 2161		
Total Price, exclusive of VAT:							
VAT 15% (if applicable)							
Unconditional Discount(s)							
Total Inclusive of VAT (where applicable)							

 Respondent's Signature

 Date & Company Stamp

Category F (Catenary wires)							
Item No	Material Number	Description	Unit	Quantity	Drawing /Specification	Unit rate	Total delivered Price of Item
SCS warehouse in Krugersdorp							
1	54011471	WIRE, ELECTRICAL; TYPE: CATENARY, CONDUCTOR DIAMETER: 80 MM2, INSULATION COLOR: NONE, POTENTIAL RATING: 25 KV, DIMENSIONS: LG 2 KM, CONDUCTOR MATERIAL: COPPER HARD DRAWN, PACKAGE TYPE: REEL, WOOD; SPECIFICATION: SANS182 PART1, 1; USED ON OHTE; STRAND 7/3.75MM	M	6000	SANS 182-1		
2	54019567	WIRE, ELECTRICAL; TYPE: CATENARY, CONDUCTOR DIAMETER: 160 MM2, INSULATION COLOR: NONE, POTENTIAL RATING: 25 KV, DIMENSIONS: LG 2 KM, CONDUCTOR MATERIAL: ALUMINIUM HARD DRAWN, PACKAGE TYPE: REEL, WOOD; ACSR; USED ON OHTE; STEEL REINFORCED; CODE NAME: TIGER; STRAND 30/7/2.36MM	M	321740	SANS 182-3		
3	54019580	WIRE, ELECTRICAL; TYPE: CATENARY, CONDUCTOR DIAMETER: 530 MM2, INSULATION COLOR: NONE, DIMENSIONS: 1 KM, CONDUCTOR MATERIAL: ALUMINIUM HARD DRAWN, PACKAGE TYPE: REEL, WOOD; SPECIFICATION: SANS182 PART3 2003, 0; ACSR; USED ON: OHTE, STEEL REINFORCED; CODE NAME: DEER ; STRAND 30/7/4.27	M	20000	SANS 182-3		
4	54032767	WIRE, ELECTRICAL; TYPE: CATENARY, CONDUCTOR DIAMETER: 160 MM2, INSULATION COLOR: NONE, DIMENSIONS: 1 KM, CONDUCTOR MATERIAL: ALUMINIUM HARD DRAWN, PACKAGE TYPE: REEL, WOOD; USED ON OHTE; STEEL REINFORCED; CODE NAME: TIGER; STRAND 30/7/2.36 MM	M	80780	SANS182 PART3 2003		
5	54032755	WIRE, ELECTRICAL; TYPE: CATENARY, CONDUCTOR DIAMETER: 530 MM2, INSULATION COLOR: NONE, DIMENSIONS: LG 500 M, CONDUCTOR MATERIAL: ALUMINIUM HARD DRAWN, INSULATION MATERIAL: NON INSULATED, PACKAGE TYPE: REEL, WOOD; SPECIFICATION: SANS182 PART3 , LA; ITEM USED ON: OHTE; STEEL REINFORCED; CODE NAME: DEER; STRAND 30/7/4.27	M	32000	SANS182 PART3		
Total Price, exclusive of VAT:							
VAT 15% (if applicable)							
Unconditional Discount(s)							
Total Inclusive of VAT (where applicable)							

Respondent's Signature

Date & Company Stamp

Category G (Contact wires)							
Item No	Material Number	Description	Unit	Quantity	Drawing /Specification	Unit rate	Total delivered Price of Item
SCS warehouse in Krugersdorp							
1	54013041	WIRE, ELECTRICAL; TYPE: CONTACT, CONDUCTOR DIAMETER: 161 MM2, INSULATION COLOR: NONE, POTENTIAL RATING: 3 KV, DIMENSIONS: LG 1.83 KM, CONDUCTOR MATERIAL: COPPER, INSULATION MATERIAL: NON INSULATED, SPECIAL FEATURES: GROOVED, PACKAGE TYPE: DRUM WOOD; SPECIFICATION: CEE.0241.2009, LA; MATERIAL NUMBER; 54013041; FOR SPOORNET USE ONLY; USED ON OHTE	M	79250	CEE 0241-2009		
2	54039839	WIRE, ELECTRICAL; TYPE: CONTACT WIRE, CONDUCTOR DIAMETER: 107 MM2, INSULATION COLOR: NONE, POTENTIAL RATING: 25 KVAC, CONDUCTOR MATERIAL: COPPER, SPECIAL FEATURES: GROOVED, PACKAGE TYPE: WOODEN DRUM 1620 M; SPECIFICATION: CEE.0241.2009, LA; USED ON OHTE	M	4860	CEE 0241-2009		
3	54032666	WIRE, ELECTRICAL; TYPE: CONTACT WIRE, CONDUCTOR DIAMETER: 107 MM2, INSULATION COLOR: NONE, POTENTIAL RATING: 25 KV, DIMENSIONS: LG 810 M, CONDUCTOR MATERIAL: COPPER, SPECIAL FEATURES: GROOVED, PACKAGE TYPE: WOOD DRUM; SPECIFICATION: CEE-0241, LA; EQUIPMENT USED ON OHTE	M	810	CEE.0241		
4	54032678	WIRE, ELECTRICAL; TYPE: CONTACT, CONDUCTOR DIAMETER: 161 MM2, INSULATION COLOR: NONE, POTENTIAL RATING: 3 KV, DIMENSIONS: 915 M, CONDUCTOR MATERIAL: COPPER, SPECIAL FEATURES: GROOVED, PACKAGE TYPE: DRUM 915 M; SPECIFICATION: CEE.0241, LA	M	915	CEE.0241		
5	54034135	WIRE, ELECTRICAL; TYPE: CONTACT, CONDUCTOR DIAMETER: 107 MM2, INSULATION COLOR: NONE, DIMENSIONS: LG 1620 M, CONDUCTOR MATERIAL: COPPER MAGNESIUM, CONDUCTOR FINISH: MARKING THREE IDENTIFICATION GROOVES ON UPPER LOBE, PACKAGE TYPE: DRUM WOOD; SPECIFICATION: BBD 7267, LA	M	71280	BBD 7267		

Respondent's Signature

Date & Company Stamp

Item No	Material Number	Description	Unit	Quantity	Drawing /Specification	Unit rate	Total delivered Price of Item
6	54034147	WIRE, ELECTRICAL; TYPE: CONTACT, CONDUCTOR DIAMETER: 161 MM2, INSULATION COLOR: NONE, DIMENSIONS: LG 1830 M CONDUCTOR MATERIAL: COPPER MAGNESIUM, INSULATION MATERIAL: NON INSULATED, CONDUCTOR FINISH: MARKING THREE IDENTIFICATION GROOVES ON UPPER LOBE, PACKAGE TYPE: WOODEN DRUM; SPECIFICATION: BBD 7267, LA	M	107530	BBD 7267		
Total Price, exclusive of VAT:							
VAT 15% (if applicable)							
Unconditional Discount(s)							
Total Inclusive of VAT (where applicable)							

Respondents are to note that Transnet will round off final pricing scores to the nearest 2 (two) decimal places.

Notes to Pricing:

- a) Respondents are to note that if the price offered by the highest scoring bidder is not market-related, Transnet may not award the contract to that Respondent. Transnet may-
 - (i) negotiate a market-related price with the Respondent scoring the highest points or cancel the RFP;
 - (ii) if that Respondent does not agree to a market-related price, negotiate a market-related price with the Respondent scoring the second highest points or cancel the RFP;
 - (iii) if the Respondent scoring the second highest points does not agree to a market-related price, negotiate a market-related price with the Respondent scoring the third highest points or cancel the RFP.

If a market-related price is not agreed with the Respondent scoring the third highest points, Transnet must cancel the RFP.
- b) Prices must be quoted in South African Rand inclusive of VAT.
- c) **Transnet reserves the right to split the award per category detailed in the pricing schedule. The preference is to award all items in a single category to a single bidder. However, only in the case where no bidder can provide all items in a category, Transnet shall evaluate each item individually in that category only and determine bidder rankings for each item.**
- d) Any disbursement not specifically priced for will not be considered/accepted by Transnet.
- e) To facilitate like-for-like comparison bidders must submit pricing strictly in accordance with this pricing schedule and not utilise a different format. Deviation from this pricing schedule could result in a bid being declared non-responsive.
- f) **Prices are to be quoted on a delivered basis to Krugersdorp SCM warehouse.**
- g) Please note that should you have offered a discounted price(s), Transnet will only consider such price discount(s) in the final evaluation stage if offered on an unconditional basis.
- h) Where a Respondent's price(s) includes imported goods/items, the rate of exchange to be used must be in South African Rands for purposes of determining whether the price is market related or not and must be the currency's rate published by the South African Reserve Bank on the date of the advertisement of the bid:

Respondent's Signature

Date & Company Stamp

Currency rate of exchange utilised: _____

- i) In respect of incoterms conditions, if applicable, please refer to paragraph 25 of the General Bid Conditions which is attached to the RFP as Appendix I.
- j) Respondents, if awarded the contract, are required to indicate that their prices quoted would be kept firm and fixed for the contract duration. [Not to be confused with bid validity period Section 2, clause 1]

YES	
------------	--

1. DISCLOSURE OF CONTRACT INFORMATION

PRICES TENDERED

Respondents are to note that, on award of business, Transnet is required to publish the tendered prices of the successful and unsuccessful Respondents *inter alia* on the National Treasury e-Tender Publication Portal, (www.etenders.gov.za), as required per National Treasury Instruction Note 01 of 2015/2016.

JOHANNESBURG STOCK EXCHANGE DEBT LISTING REQUIREMENTS

Transnet may also be required to disclose information relating to the subsequent contract i.e. the name of the company, goods/services provided by the company, the value and duration of the contract, etc. in compliance with the Johannesburg Stock Exchange (JSE) Debt Listing Requirements.

DOMESTIC PROMINENT INFLUENTIAL PERSONS (DPIP) OR FOREIGN PROMINENT PUBLIC OFFICIALS (FPPO)

Transnet is free to procure the services of any person within or outside the Republic of South Africa in accordance with applicable legislation. Transnet shall not conduct or conclude business transactions, with any Respondents without having:

- Considered relevant governance protocols;
- Determined the DPIP or FPPO status of that counterparty; and
- Conducted a risk assessment and due diligence to assess the potential risks that may be posed by the business relationship.

As per the Transnet Domestic Prominent Influential Persons (DPIP) and Foreign Prominent Public Officials (FPPO) and Related Individuals Policy available on Transnet website <https://www.transnet.net/search/pages/results.aspx?k=FPIDP#k=DPIP>, Respondents are required to disclose any commercial relationship with a DPIP or FPPO (as defined in the Policy) by completing the following section:

The below form contains personal information as defined in the Protection of Personal Information Act, 2013 (the "Act"). By completing the form, the signatory consents to the processing of her/his personal information in accordance with the requirements of the Act. Consent cannot unreasonably be withheld.						
Is the Respondent (Complete with a "Yes" or "No")						
A DPIP/FPPO		Closely Related to a DPIP/FPPO		Closely Associated to a DPIP/FPPO		
List all known business interests, in which a DPIP/FPPO may have a direct/indirect interest or significant participation or involvement.						
No	Name of Entity / Business	Role in the Entity / Business (Nature of interest/ Participation)	Shareholding %	Registration Number	Status (Mark the applicable option with an X)	
					Active	Non-Active

 Respondent's Signature

 Date & Company Stamp

1						
2						
3						

Respondents declaring a commercial relationship with a DPIP or FPPO are to note that Transnet is required to annually publish on its website a list of all business contracts entered into with DPIP or FPPO. This list will include successful Respondents, if applicable.

2. RETURN OF SURPLUS GOODS

Respondents are required to indicate whether they have a return policy in place (if so attach a copy):

YES		NO	
------------	--	-----------	--

Respondents are required to indicate a reasonable timeframe during which Transnet may return any surplus goods:

3. PRE-PRODUCTION SAMPLES/PROTOTYPES

3.1 In this RFP, Respondents are required to provide a pre-production sample(s) or prototype(s). The Respondent should state here the time required to deliver the necessary pre-production samples(s) or prototype(s) calculated as from the date of notification of acceptance of its Proposal by Transnet:

3.2 NB: Purchase Orders will be placed on the Supplier(s) only after the date of approval of the pre-production sample(s).

3.3 State the number of days/weeks/months after which delivery would commence subject to Transnet’s approval of the pre-production sample(s) or prototype(s), calculated as from the date of such approval:

4. MANUFACTURERS

The Respondents must state hereunder the actual manufacturer(s) of the Goods tendered for:

4.1 Local Manufacturer(s):

RFP ITEM NO.	NAME	BUSINESS ADDRESS

4.2 Foreign Manufacturer(s):

RFP ITEM NO.	NAME	BUSINESS ADDRESS

5. INSPECTION DETAILS

The Respondents must state the actual name(s) and address/addresses of the suppliers of the Goods for inspection purposes only:

5.1 Local Manufacturer(s)

RFP ITEM NO.	NAME	BUSINESS ADDRESS

5.2 Foreign Manufacturer(s):

RFP ITEM NO.	NAME	BUSINESS ADDRESS

6. IMPORTED CONTENT

The Respondents must state hereunder the value and percentage of the imported content as well as the country of origin in respect of each item tendered for:

RFP ITEM NO / DESCRIPTION.	VALUE	% COST	COUNTRY OF ORIGIN

Note: Where more than one country is applicable to one item, the Respondents must furnish this information separately.

7. EXCHANGE AND REMITTANCE

The attention of the Respondents is directed to clause 17 [*Exchange and Remittance*] of the General Bid Conditions. If Transnet is requested by the Respondent to effect payment overseas direct to the Respondent’s principal or supplier, which is not a registered South African Company please complete the details below, using the rate of exchange published by the South African Reserve Bank 7 [seven] calendar days before the closing date of this RFP:

7.1 ZAR 1.00 [South African currency] being equal to _____ [*foreign currency*]

7.2 _____ % in relation to tendered price(s) to be remitted overseas by Transnet

7.3 _____ [Name of country to which payment is to be made]

7.4 Beneficiary details:

Name [Account holder] _____

Bank [Name and branch code] _____

Swift code _____

Country _____

7.5 _____ [Applicable base date of Exchange Rate used]

Respondents are advised that should a contract be awarded for deliveries on an “as and when required” basis, any future remittance(s) to overseas principals/service providers, as instructed above, will be based on an agreed rate of exchange related to the contractual price of the Goods/Services at that time.

Respondents should note that Transnet would prefer to receive fixed price offers expressed in South African Rand [ZAR].

8. EXPORT CREDIT AGENCY SUPPORTED FINANCE

In order to finance its payment obligations under a future contract where foreign transactions are involved, Transnet may consider raising debt financing [an **ECA Facility**] from one or more banks or financial institutions, with the benefit of export credit agency [**ECA**] credit support to be provided by an ECA.

Under such circumstances the successful Respondent will agree to undertake:

- a) to provide [and/or cause the Parent/OEM to provide, as applicable] to Transnet and the banks and financial institutions that may participate in the ECA Facility all such assistance as an importer of Goods and/or Services, which are eligible for ECA credit supported finance by an ECA, is generally required to provide for the purposes of obtaining ECA support;
- b) not to do or [as Supplier of the relevant eligible Goods or services] omit to do anything, which may adversely affect Transnet’s prospects of qualifying for or, once obtained, maintaining ECA credit support by an ECA in respect of an ECA Facility.

All cost, expenses, charges and liabilities incurred by Transnet in establishing an ECA Facility with credit support from an Export Credit Agency, may be for the account of Transnet.

9. NATIONAL RAILWAY SAFETY REGULATOR ACT

In compliance with the National Railway Safety Regulator Act, 16 of 2002, the successful Respondent [**the Supplier**] shall ensure that the Goods to be supplied to Transnet, under the terms and conditions of a contract between the parties, comply fully with the specifications as set out in Annexure B [*Specifications and Drawings*] of this RFP, and shall also adhere to railway safety requirements and/or regulations [as applicable]. Permission for the engagement of a subcontractor by the Supplier, as applicable, both initially and during the course of a contract, shall be subject to a review of the capability of the proposed subcontractor to comply with the specified railway safety requirements and/or regulations. The Supplier and/or its subcontractor shall grant Transnet access, during the term of the contract, to review any safety-related activities, including the coordination of such activities across all parts of the organisation.

Accepted:

YES	
------------	--

NO	
-----------	--

10. SERVICE LEVELS

10.1 An experienced regional account representative(s) is required to work with Transnet’s procurement department. [No sales representatives are needed for individual department or locations]. Additionally, there shall be a minimal number of people, fully informed and accountable for this agreement.

10.2 Transnet will have quarterly reviews with the Supplier’s account representative on an on-going basis.

10.3 Transnet reserves the right to request that any member of the Supplier’s team involved on the Transnet account be replaced if deemed not to be adding value for Transnet.

10.4 The Supplier guarantees that it will achieve a 95% [ninety-five per cent] service level on the following measures:

- a) Random checks on compliance with quality/quantity/specifications
- b) On-time delivery

If the Supplier does not achieve this level as an average over each quarter, Transnet will receive a 1.5% [one and a half per cent] rebate on quarterly sales payable in the next quarter.

10.5 The Supplier must provide a telephone number for customer service calls.

10.6 Failure of the Supplier to comply with stated service level requirements will give Transnet the right to cancel the contract in whole, without penalty to Transnet, giving 30 [thirty] calendar days' notice to the Supplier of its intention to do so.

Acceptance of Service Levels:

YES	
------------	--

NO	
-----------	--

11. RISK

Respondents must elaborate on the control measures put in place by their entity, which would mitigate the risk to Transnet pertaining to potential non-performance by the Respondent, in relation to:

11.1 Quality and specification of Goods/Services delivered:

11.2 Continuity of supply:

11.3 Compliance with the Occupational Health and Safety Act, 85 of 1993:

11.4 Compliance with the National Railway Safety Regulator Act, 16 of 2002:

SIGNED at _____ on this ____ day of _____ 20__

SIGNATURE OF WITNESSES

ADDRESS OF WITNESSES

1 _____

Name _____

2 _____

Name _____

SIGNATURE OF RESPONDENT'S AUTHORISED REPRESENTATIVE: _____

NAME: _____

DESIGNATION: _____

SECTION 5: PROPOSAL FORM AND LIST OF RETURNABLE DOCUMENTS

I/We _____
 [name of entity, company, close corporation or partnership] of [full address]

carrying on business trading/operating as

represented by _____

in my capacity as _____

being duly authorised thereto by a Resolution of the Board of Directors or Members or Certificate of Partners, dated _____ to enter into, sign execute and complete any documents relating to this proposal and any subsequent Agreement. The following list of persons are hereby authorised to negotiate on behalf of the abovementioned entity, should Transnet decide to enter into Post Tender Negotiations with highest ranked bidder(s).

FULL NAME(S)	CAPACITY	SIGNATURE
_____	_____	_____
_____	_____	_____
_____	_____	_____
_____	_____	_____

I/We hereby offer to supply/provide the abovementioned Goods/Services at the prices quoted in the schedule of prices in accordance with the terms set forth in the documents listed in the accompanying schedule of RFP documents.

I/We agree to be bound by those conditions in Transnet's:

- (i) Master Agreement (which may be subject to amendment at Transnet's discretion if applicable);
- (ii) General Bid Conditions; and
- (iii) any other standard or special conditions mentioned and/or embodied in this Request for Proposal.

I/We accept that unless Transnet should otherwise decide and so inform me/us in the letter of award, this Proposal [and, if any, its covering letter and any subsequent exchange of correspondence], together with Transnet's acceptance thereof shall constitute a binding contract between Transnet and me/us.

Should Transnet decide that a formal contract should be signed and so inform me/us in a letter of award [the **Letter of Award**], this Proposal [and, if any, its covering letter and any subsequent exchange of correspondence] together with Transnet's Letter of Award, shall constitute a binding contract between Transnet and me/us until the formal contract is signed.

I/We further agree that if, after I/we have been notified of the acceptance of my/our Proposal, I/we fail to enter into a formal contract if called upon to do so, or fail to commence the supply/provision of Goods/Services within 2 [two] weeks thereafter, Transnet may, without prejudice to any other legal remedy which it may have, recover from me/us any expense to which it may have been put in calling for Proposals afresh and/or having to accept any less favourable Proposal.

 Respondent's Signature

 Date & Company Stamp

Furthermore, I/we agree to a penalty clause/s which will allow Transnet to invoke a penalty against us for non-compliance with material terms of this RFP including the delayed delivery of the Goods/Services due to non-performance by ourselves, , etc.

I/we agree that non-compliance with any of the material terms of this RFP, including those mentioned above, will constitute a material breach of contract and provide Transnet with cause for cancellation.

ADDRESS FOR NOTICES

The law of the Republic of South Africa shall govern any contract created by the acceptance of this RFP. The *domicilium citandi et executandi* shall be a place in the Republic of South Africa to be specified by the Respondent hereunder, at which all legal documents may be served on the Respondent who shall agree to submit to the jurisdiction of the courts of the Republic of South Africa. Foreign Respondents shall, therefore, state hereunder the name of their authorised representative in the Republic of South Africa who has the power of attorney to sign any contract which may have to be entered into in the event of their Proposal being accepted and to act on their behalf in all matters relating to such contract.

Respondent to indicate the details of its *domicilium citandi et executandi* hereunder:

Name of Entity: _____

Facsimile: _____

Address: _____

NOTIFICATION OF AWARD OF RFP

As soon as possible after approval to award the contract(s), the successful Respondent [**the Supplier**] will be informed of the acceptance of its Proposal. Transnet will also publish the outcome of the tender, including successful and unsuccessful bidders, in the National Treasury e-tender portal. Any unsuccessful bidder has a right to request reasons for the bid not to be successful and Transnet has a duty to provide those reasons on receipt of the request from the bidder.

VALIDITY PERIOD

Transnet requires a validity period of 180 Business Days [from closing date] – **15 FEBRUARY 2027** against this RFP, excluding the first day and including the last day.

NAME(S) AND ADDRESS / ADDRESSES OF DIRECTOR(S) OR MEMBER(S)

The Respondent must disclose hereunder the full name(s) and address(s) of the director(s) or members of the company or close corporation [**C.C.**] on whose behalf the RFP is submitted.

(i) Registration number of company / C.C. _____

(ii) Registered name of company / C.C. _____

(iii) Full name(s) of director/member(s) Address/Addresses ID Number(s)

RETURNABLE DOCUMENTS

Returnable Documents means all the documents, Sections and Annexures, as listed in the tables below. There are three types of returnable documents as indicated below and Respondents are urged to ensure that these documents are returned with their bids based on the consequences of non-submission as indicated below:

Mandatory Returnable Documents	<i>Failure to provide all these Mandatory Returnable Documents at the Closing Date and time of this RFP <u>will</u> result in a Respondent’s disqualification.</i>
Returnable Documents Used for Scoring	<i>Failure to provide all Returnable Documents used for purposes of scoring a bid, by the closing date and time of this bid will not result in a Respondent’s disqualification. However, Bidders will receive an automatic score of zero for the applicable evaluation criterion.</i>
Essential Returnable Documents	<i>Failure to provide essential Returnable Documents <u>will</u> result in Transnet affording Respondents a further opportunity to submit by a set deadline. Should a Respondent thereafter fail to submit the requested documents, this may result in a Respondent’s disqualification.</i>

All Returnable Sections, as indicated in the header and footer of the relevant pages, must be signed, stamped and dated by the Respondent.

a) Mandatory Returnable Documents

Respondents are required to submit with their bid submissions the following **Mandatory Returnable Documents**, and also to confirm submission of these documents by so indicating [Yes or No] in the tables below:

Mandatory Returnable Documents	Submitted [Yes or No]
SECTION 4: Pricing and Delivery Schedule	

b) Returnable Documents Used for Scoring

In addition to the requirements of section (a) above, Respondents are further required to submit with their Proposals the following **Returnable Documents Used for Scoring** and also to confirm submission of these documents by so indicating [Yes or No] in the table below:

Returnable Documents Used for Scoring	Submitted [Yes or No]
Respondent’s valid proof of evidence to claim points for compliance with Specific Goals’ requirements as stipulated in Section 9 of this RFP	
B-BBEE Certificate / Sworn- Affidavit / B-BBEE CIPC Certificate (in case of JV, a consolidated scorecard will be accepted) as per DTIC guideline.	
ANNEXURE A: Tender Evaluation Methodology	
Compliant Memorandum of Understanding (MOU) OR Authorization Letter from OEM OR OEM Confirmation letter	
Transnet stamped or signed drawings or specifications or Drawings or specification from OEM/Manufacturer proving compliance to given drawings, specs, SANS and other standards in the item descriptions.	
Valid ISO 9001 accreditation(s) or an ISO Quality plan(s) of the manufacturing facility/facilities that will be manufacturing the items	

Returnable Documents Used for Scoring	Submitted [Yes or No]
Proof of testing completed/Inspection certificate, and Delivery note or Invoice	
ANNEXURE C, D,E LOCAL CONTENT	

c) Essential Returnable Documents:

Over and the above the requirements of section (a) and (b) mentioned above, Respondents are further required to submit with their Proposals the following **Essential Returnable Documents** and also to confirm submission of these documents by so indicating [Yes or No] in the table below:

Essential Returnable Documents & Schedules	Submitted [Yes or No]
In the case of Joint Ventures, a copy of the Joint Venture Agreement or written confirmation of the intention to enter into a Joint Venture Agreement	
SECTION 1: SBD1 FORM	
SECTION 5: Proposal Form and List of Returnable documents	
SECTION 6: RFQ Declaration Certificate of Acquaintance & Breach of Law Form with RFP	
SECTION 7: RFP Clarification Request Form	
SECTION 8: Specific goals points claim form	
SECTION 9: Protection of Personal Information	

CONTINUED VALIDITY OF RETURNABLE DOCUMENTS

The successful Respondent will be required to ensure the validity of all returnable documents, including but not limited to its valid proof of B-BBEE status, for the duration of any contract emanating from this RFP. Should the Respondent be awarded the contract [**the Agreement**] and fail to present Transnet with such renewals as and when they become due, Transnet shall be entitled, in addition to any other rights and remedies that it may have in terms of the eventual Agreement, to terminate such Agreement immediately without any liability and without prejudice to any claims which Transnet may have for damages against the Respondent.

SIGNED at _____ on this ____ day of _____ 20__

SIGNATURE OF WITNESSES

ADDRESS OF WITNESSES

1 _____

Name _____

2 _____

Name _____

SIGNATURE OF RESPONDENT’S AUTHORISED REPRESENTATIVE: _____

NAME: _____

DESIGNATION: _____

SECTION 6: RFQ DECLARATION CERTIFICATE OF ACQUAINTANCE & BREACH OF LAW FORM WITH RFP

By signing this certificate the Respondent is deemed to acknowledge that he/she has made himself/herself thoroughly familiar with, and agrees with all the conditions governing this RFP. This includes those terms and conditions contained in any printed form stated to form part hereof, including but not limited to the documents stated below. As such, Transnet SOC Ltd will recognise no claim for relief based on an allegation that the Respondent overlooked any such term or condition or failed properly to take it into account for the purpose of calculating tendered prices or any other purpose:

1	Transnet's General Bid Conditions
2	Master Agreement attached
3	Transnet's Supplier Integrity Pact
4	Non-disclosure Agreement
5	Specifications and drawings attached to this RFP

Note: Should a Respondent be successful and awarded the bid, they will be required to complete a Supplier Declaration Form for registration as a vendor onto the Transnet vendor master database.

Should the Bidder find any terms or conditions stipulated in any of the relevant documents quoted in the RFP unacceptable, it should indicate which conditions are unacceptable and offer alternatives by written submission on its company letterhead, attached to its submitted Bid. Any such submission shall be subject to review by Transnet's Legal Counsel who shall determine whether the proposed alternative(s) are acceptable or otherwise, as the case may be. A material deviation from any term or condition may result in disqualification.

Bidders accept that an obligation rests on them to clarify any uncertainties regarding any bid to which they intend to respond on, before submitting the bid. **The Bidder agrees that he/she will have no claim or cause of action based on an allegation that any aspect of this RFP was unclear but in respect of which he/she failed to obtain clarity.**

The bidder understands that his/her Bid will be disqualified if the Certificate of Acquaintance with RFP documents included in the RFP as a returnable document, is found not to be true and complete in every respect.

We hereby certify that:

1. Transnet has supplied and we have received appropriate responses to any/all questions [as applicable] which were submitted by ourselves for RFP Clarification purposes;
2. We have received all information we deemed necessary for the completion of this Request for Proposal [**RFP**];
3. We have been provided with sufficient access to the existing Transnet facilities/sites and any and all relevant information relevant to the Goods/Services as well as Transnet information and Employees, and have had sufficient time in which to conduct and perform a thorough due diligence of Transnet's operations and business requirements and assets used by Transnet. Transnet will therefore not consider or permit any pre- or post-contract verification or any related adjustment to pricing, service levels or any other provisions/conditions based on any incorrect assumptions made by the Respondent in arriving at his Bid Price.

Respondent's Signature

Date & Company Stamp

4. At no stage have we received additional information relating to the subject matter of this RFP from Transnet sources, other than information formally received from the designated Transnet contact(s) as nominated in the RFP documents;
5. We are satisfied, insofar as our entity is concerned, that the processes and procedures adopted by Transnet in issuing this RFP and the requirements requested from Bidders in responding to this RFP have been conducted in a fair and transparent manner;
6. We have complied with all obligations of the Bidder/Supplier as indicated in the Transnet Supplier Integrity which includes but are not limited to ensuring that we take all measures necessary to prevent corrupt practices, unfairness and illegal activities in order to secure or in furtherance to secure a contract with Transnet;
7. we declare that an owner / member / director / partner / shareholder/employee of our entity **has / has not been** [delete as applicable] a former employee or board member of Transnet in the past 10 years. I further declare that if they were a former employee or board member of Transnet in the past 10 years that they **were/were not** involved in the bid preparation or had access to the information related to this RFP; and
8. If such a relationship as indicated in paragraph 7, exists, the Respondent is to complete the following section:

FULL NAME OF OWNER/MEMBER/DIRECTOR/
PARTNER/SHAREHOLDER/EMPLOYEE:

ADDRESS:

Indicate nature of relationship with Transnet:

[Failure to furnish complete and accurate information in this regard will lead to the disqualification of a response and may preclude a Respondent from doing future business with Transnet. Information provided in the declarations may be used by Transnet and/or its affiliates to verify the correctness of the information provided]

9. We declare, to the extent that we are aware or become aware of any relationship between ourselves and Transnet [other than any existing and appropriate business relationship with Transnet] which could unfairly advantage our entity in the forthcoming adjudication process, we shall notify Transnet immediately in writing of such circumstances.

BIDDER’S DISCLOSURE (SBD4)

12 PURPOSE OF THE FORM

12.1 Any person (natural or juristic) may make an offer or offers in terms of this invitation to bid. In line with the principles of transparency, accountability, impartiality, and ethics as enshrined in the Constitution of the Republic of South Africa and further expressed in various pieces of legislation, it is required for the bidder to make this declaration in respect of the details required hereunder.

12.2 Where a person/s are listed in the Register for Tender Defaulters and / or the List of Restricted Suppliers, that person will automatically be disqualified from the bid process.

13 Bidder’s declaration

13.1 Is the bidder, or any of its directors / trustees / shareholders / members / partners or any person having a controlling interest¹ in the enterprise, employed by the state? **YES/NO**

13.1.1. If so, furnish particulars of the names, individual identity numbers, and, if applicable, state employee numbers of sole proprietor/ directors / trustees / shareholders / members/ partners or any person having a controlling interest in the enterprise, in table below.

Full Name	Identity Number	Name of State institution

13.2 Do you, or any person connected with the bidder, have a relationship with any person who is employed by the procuring institution? **YES/NO**

13.2.1. If so, furnish particulars:

13.3 Does the bidder or any of its directors / trustees / shareholders / members / partners or any person having a controlling interest in the enterprise have any interest in any other related enterprise whether or not they are bidding for this contract? **YES/NO**

13.3.1. If so, furnish particulars:

14 DECLARATION

I, the undersigned, (name)..... in submitting the accompanying bid, do hereby make the following statements that I certify to be true and complete in every respect:

14.1 I have read and I understand the contents of this disclosure;

¹ the power, by one person or a group of persons holding the majority of the equity of an enterprise, alternatively, the person/s having the deciding vote or power to influence or to direct the course and decisions of the enterprise.

- 14.2 I understand that the accompanying bid will be disqualified if this disclosure is found not to be true and complete in every respect;
- 14.3 The bidder has arrived at the accompanying bid independently from, and without consultation, communication, agreement or arrangement with any competitor. However, communication between partners in a joint venture or consortium² will not be construed as collusive bidding.
- 14.4 In addition, there have been no consultations, communications, agreements or arrangements with any competitor regarding the quality, quantity, specifications, prices, including methods, factors or formulas used to calculate prices, market allocation, the intention or decision to submit or not to submit the bid, bidding with the intention not to win the bid and conditions or delivery particulars of the products or services to which this bid invitation relates.
- 14.5 The terms of the accompanying bid have not been, and will not be, disclosed by the bidder, directly or indirectly, to any competitor, prior to the date and time of the official bid opening or of the awarding of the contract.
- 14.6 There have been no consultations, communications, agreements or arrangements made by the bidder with any official of the procuring institution in relation to this procurement process prior to and during the bidding process except to provide clarification on the bid submitted where so required by the institution; and the bidder was not involved in the drafting of the specifications or terms of reference for this bid.
- 14.7 I am aware that, in addition and without prejudice to any other remedy provided to combat any restrictive practices related to bids and contracts, bids that are suspicious will be reported to the Competition Commission for investigation and possible imposition of administrative penalties in terms of section 59 of the Competition Act No 89 of 1998 and or may be reported to the National Prosecuting Authority (NPA) for criminal investigation and or may be restricted from conducting business with the public sector for a period not exceeding ten (10) years in terms of the Prevention and Combating of Corrupt Activities Act No 12 of 2004 or any other applicable legislation.

I CERTIFY THAT THE INFORMATION FURNISHED IN PARAGRAPHS 12, 13 and 14 ABOVE IS CORRECT.

I ACCEPT THAT THE STATE MAY REJECT THE BID OR ACT AGAINST ME IN TERMS OF PARAGRAPH 6 OF PFMA SCM INSTRUCTION 03 OF 2021/22 ON PREVENTING AND COMBATING ABUSE IN THE SUPPLY CHAIN MANAGEMENT SYSTEM SHOULD THIS DECLARATION PROVE TO BE FALSE.

BREACH OF LAW

We further hereby certify that *I/we* (the bidding entity and/or any of its directors, members or partners) **have/have not been** [delete as applicable] found guilty during the preceding 5 [five] years of a serious breach of law, including but not limited to a breach of the Competition Act, 89 of 1998, by a court of law, tribunal or other administrative body. The type of breach that the Respondent is required to disclose excludes relatively minor offences or misdemeanours, e.g. traffic offences. This includes the imposition of an administrative fine or penalty.

Where found guilty of such a serious breach, please disclose:

² Joint venture or Consortium means an association of persons for the purpose of combining their expertise, property, capital, efforts, skill and knowledge in an activity for the execution of a contract.

NATURE OF BREACH:

DATE OF BREACH: _____

Furthermore, I/we acknowledge that Transnet SOC Ltd reserves the right to exclude any Respondent from the bidding process, should that person or entity have been found guilty of a serious breach of law, tribunal or regulatory obligation.

SIGNED at _____ on this ____ day of _____ 20__

For and on behalf of _____ duly authorised hereto	AS WITNESS:
Name:	Name:
Position:	Position:
Signature:	Signature:
Date:	Registration No of Company/CC
Place:	Registration Name of Company/CC

SECTION 8 : SPECIFIC GOALS POINTS CLAIM FORM

This preference form must form part of all bids invited. It contains general information and serves as a claim for preference points for specific goals Contribution. Transnet will award preference points to companies who provide valid proof of evidence of as per the table below.

NB: BEFORE COMPLETING THIS FORM, BIDDERS MUST STUDY THE GENERAL CONDITIONS, DEFINITIONS AND DIRECTIVES APPLICABLE IN RESPECT OF SPECIFIC GOALS, AS PRESCRIBED IN THE PREFERENTIAL PROCUREMENT POLICY FRAMEWORK ACT, 2000.

1. GENERAL CONDITIONS

- 1.1 The following preference point systems are applicable to all bids:
 - the 80/20 system for requirements with a Rand value of up to R50 000 000 (all applicable taxes included); and
 - the 90/10 system for requirements with a Rand value above R50 000 000 (all applicable taxes included).
- 1.2 Either the 80/20 or 90/10 preference point system will apply. The lowest acceptable bid will determine the preference point system.
- 1.3 Preference points for this bid shall be awarded for:
 - (a) Price;
 - (b) B-BBEE Status Level of Contribution; and
 - (c) Any other specific goal determined in Transnet preferential procurement policy.
- 1.4 The maximum points for this bid are allocated as follows:

PRICE	POINTS	
	90	80
SPECIFIC GOALS		
B-BBEE Level of contributor (1 or 2) and,	2	4
Entities that are at least 51% Black Owned	2	4
At least 30% Black Women Owned Entities	2	4
Local Content and production	4	8
Electrical cables designated at 90%		
Steel wires designated at 100%		
Fully completed Local content annexures C D and E scores full 4 points		
Incomplete submitted blank or not submitted Local content annexures C D and E score zero points		
In case the suppliers do not meet required Local Content thresholds, DTIC Exemption letter will be required in support for scoring purposes (exemption process attached)		
Total points for Price and Specific Goals must not exceed	100	100

- 1.5 Failure on the part of a bidder to submit proof of evidence for any of the specific goals together with the bid will be interpreted to mean that preference points are not claimed.
- 1.6 The purchaser reserves the right to require of a bidder, either before a bid is adjudicated or at any time subsequently, to substantiate any claim in regard to preferences, in any manner required by the purchaser.

Respondent's Signature _____

Date & Company Stamp _____

2. DEFINITIONS

- (a) **“all applicable taxes”** includes value-added tax, pay as you earn, income tax, unemployment insurance fund contributions and skills development levies;
- (b) **“B-BBEE”** means broad-based black economic empowerment as defined in section 1 of the Broad-Based Black Economic Empowerment Act;
- (c) **“B-BBEE status level of contributor”** means the B-BBEE status received by a measured entity based on its overall performance using the relevant scorecard contained in the Codes of Good Practice on Black Economic Empowerment, issued in terms of section 9(1) of the Broad-Based Black Economic Empowerment Act;
- (d) **“Ownership”** means 51% black ownership
- (e) **“bid”** means a written offer in a prescribed or stipulated form in response to an invitation by an organ of state for the supply/provision of services, works or goods, through price quotations, advertised competitive bidding processes or proposals;
- (f) **“Broad-Based Black Economic Empowerment Act”** means the Broad-Based Black Economic Empowerment Act, 2003 (Act No. 53 of 2003);
- (g) **“EME”** means an Exempted Micro Enterprise as defines by Codes of Good Practice under section 9 (1) of the Broad-Based Black Economic Empowerment Act, 2003 (Act No. 53 of 2003);
- (h) **“functionality”** means the ability of a bidder to provide goods or services in accordance with specification as set out in the bid documents
- (i) **“Price”** includes all applicable taxes less all unconditional discounts.
- (j) **“Proof of B-BBEE Status Level of Contributor”**
 - i) the B-BBBEE status level certificate issued by an authorised body or person;
 - ii) a sworn affidavit as prescribed by the B-BBEE Codes of Good Practice; or
 - iii) any other requirement prescribed in terms of the B-BBEE Act.
- (k) **“QSE”** means a Qualifying Small Enterprise as defines by Codes of Good Practice under section 9 (1) of the Broad-Based Black Economic Empowerment Act, 2003 (Act No. 53 of 2003);
- (l) **“rand value”** means the total estimated value of a contract in South African currency, calculated at the time of bid invitations, and includes all applicable taxes and excise duties.
- (m) **“Specific goals”** means targeted advancement areas or categories of persons or groups either previously disadvantaged or falling within the scope of the Reconstruction and Development Programme identified by Transnet to be given preference in allocation of procurement contracts in line with section 2(1) of the PPPFA.

3. POINTS AWARDED FOR PRICE

3.1 THE 80/20 OR 90/10 PREFERENCE POINT SYSTEMS

A maximum of 80 or 90 points is allocated for price on the following basis:

$$PS = 80 \left(1 + \frac{Pt - P_{max}}{P_{max}} \right) \text{ OR } PS = 90 \left(1 + \frac{Pt - P_{max}}{P_{max}} \right)$$

Where

- Ps = Points scored for comparative price of bid under consideration
- Pt = Comparative price of bid under consideration
- Pmin = Comparative price of lowest acceptable bid

In terms of Transnet Preferential Procurement Policy (TPPP) and Procurement Manuals, the following preference points must be awarded to a bidder who provides the relevant required evidence for claiming points

3.2

Selected Specific Goal	Number of points allocated (10)
B-BBEE Level of contributor (1 or 2)	2
Entities that are at least 51% Black Owned	2
At least 30% Black Women Owned Entities	2
Local Content and production Electrical cables designated at 90% Steel wires designated at 100% <ul style="list-style-type: none"> Fully completed Local content annexures C D and E scores full 4 points Incomplete submitted blank or not submitted Local content annexures C D and E score zero points In case the suppliers do not meet required Local Content thresholds, DTIC Exemption letter will be required in support for scoring purposes (exemption process attached)	4
Non-Compliant and/or B-BBEE Level 3-8 contributors	0

Or

Selected Specific Goal	Number of points allocated (20)
B-BBEE Level of contributor (1 or 2)	4
Entities that are at least 51% Black Owned	4
At least 30% Black Women Owned Entities	4
Local Content and production Electrical cables designated at 90% Steel wires designated at 100% <ul style="list-style-type: none"> Fully completed Local content annexures C D and E scores full 4 points Incomplete submitted blank or not submitted Local content annexures C D and E score zero points In case the suppliers do not meet required Local Content thresholds, DTIC Exemption letter will be required in support for scoring purposes (exemption process attached)	8
Non-Compliant and/or B-BBEE Level 3-8 contributors	0

Note: Either the 80/20 or 90/10 preference point system will apply. The lowest acceptable bid will determine the preference point system per Category of conductors Schedule.

4. EVIDENCE REQUIRED FOR CLAIMING SPECIFIC GOALS

4.1 In terms of Transnet Preferential Procurement Policy (TPPP) and Procurement Manuals, preference points must be awarded to a bidder for providing evidence in accordance with the table below:

Specific Goals	Acceptable Evidence
B-BBEE	B-BBEE Certificate / Sworn- Affidavit / B-BBEE CIPC Certificate (in case of JV, a consolidated scorecard will be accepted) as per DTIC guideline
Entities that are 51% Black	B-BBEE Certificate / Sworn- Affidavit / B-BBEE CIPC Certificate (in case

Respondent's Signature

Date & Company Stamp

Owned	of JV, a consolidated scorecard will be accepted) as per DTIC guideline
At least 30% Black Women Owned Entities	B-BBEE Certificate / Sworn- Affidavit / B-BBEE CIPC Certificate (in case of JV, a consolidated scorecard will be accepted) as per DTIC guideline
Local Content and Production	Returnable Local Content and production Annexures

4.2 The table below indicates the required proof of B-BBEE status depending on the category of enterprises:

Enterprise	B-BBEE Certificate & Sworn Affidavit
Large	Certificate issued by SANAS accredited verification agency
QSE	Certificate issued by SANAS accredited verification agency Sworn Affidavit signed by the authorised QSE representative and attested by a Commissioner of Oaths confirming annual turnover and black ownership (only black-owned QSEs - 51% to 100% Black owned) [Sworn affidavits must substantially comply with the format that can be obtained on the DTI’s website at www.dti.gov.za/economic_empowerment/bee_codes.jsp .]
EME³	Sworn Affidavit signed by the authorised EME representative and attested by a Commissioner of Oaths confirming annual turnover and black ownership Certificate issued by CIPC (formerly CIPRO) confirming annual turnover and black ownership Certificate issued by SANAS accredited verification agency only if the EME is being measured on the QSE scorecard

- 4.3 A trust, consortium or joint venture (including unincorporated consortia and joint ventures) must submit a consolidated B-BBEE Status Level verification certificate for every separate bid.
- 4.4 Tertiary Institutions and Public Entities will be required to submit their B-BBEE status level certificates in terms of the specialized scorecard contained in the B-BBEE Codes of Good Practice.
- 4.5 A person will not be awarded points for B-BBEE status level if it is indicated in the bid documents that such a bidder intends sub-contracting more than 25% of the value of the contract to any other enterprise that does not qualify for at least the points that such a bidder qualifies for, unless the intended sub-contractor is an EME that has the capability and ability to execute the sub-contract.
- 4.6 A person awarded a contract may not sub-contract more than 25% of the value of the contract to any other enterprise that does not have an equal or higher B-BBEE status level than the person concerned, unless the contract is sub-contracted to an EME that has the capability and ability to execute the sub-contract.
- 4.7 Bidders are to note that the rules pertaining to B-BBEE verification and other B-BBEE requirements may be changed from time to time by Transnet or regulatory bodies such as National Treasury or the DTI. It is the Bidder’s responsibility to ensure that his/her bid complies fully with all B-BBEE requirements at the time of the submission of the bid.

5. BID DECLARATION

5.1 Bidders who claim points in respect of B-BBEE Status Level of Contribution must complete the following:

6. B-BBEE STATUS LEVEL OF CONTRIBUTION CLAIMED IN TERMS OF PARAGRAPHS 6.1

6.1 B-BBEE Status Level of Contribution: =(maximum of 10 or 20 points)

(Points claimed in respect of paragraph 6.1 must be in accordance with the table reflected in table 3.2 and must be substantiated by relevant proof of B-BBEE status level of contributor.

7. SUB-CONTRACTING

7.1 Will any portion of the contract be sub-contracted?

(Tick applicable box)

YES		NO	
-----	--	----	--

7.1.1 If yes, indicate:

- i) What percentage of the contract will be subcontracted.....%
- ii) The name of the sub-contractor.....
- iii) The B-BBEE status level of the sub-contractor.....
- iv) Whether the sub-contractor is an EME or QSE.

(Tick applicable box)

YES		NO	
-----	--	----	--

v) Specify, by ticking the appropriate box, if subcontracting with any of the following enterprises:

Designated Group: An EME or QSE which is at least 51% owned by:	EME √	QSE √
Black people		
Black people who are youth		
Black people who are women		
Black people with disabilities		
Black people living in rural or underdeveloped areas or townships		
Cooperative owned by black people		
Black people who are military veterans		
OR		
Any EME		
Any QSE		

8. DECLARATION WITH REGARD TO COMPANY/FIRM

8.1 Name of company/firm:.....

8.2 VAT registration number:.....

8.3 Company registration number:.....

8.4 TYPE OF COMPANY/ FIRM

- Partnership/Joint Venture / Consortium
- One person business/sole propriety
- Close corporation
- Company
- (Pty) Limited

[TICK APPLICABLE BOX]

8.5 DESCRIBE PRINCIPAL BUSINESS ACTIVITIES

.....
.....

8.6 COMPANY CLASSIFICATION

- Manufacturer
- Supplier
- Professional Supplier
- Other Suppliers, e.g. transporter, etc.

[TICK APPLICABLE BOX]

8.7 Total number of years the company/firm has been in business:.....

8.8 I/we, the undersigned, who is / are duly authorised to do so on behalf of the company/firm, certify that the points claimed, based on the B-BBE status level of contribution indicated in paragraphs 6.1 of the foregoing certificate, qualifies the company/ firm for the preference(s) shown and I / we acknowledge that:

- i) The information furnished is true and correct;
- ii) The preference points claimed are in accordance with the General Conditions as indicated in paragraph 1 of this form;
- iii) In the event of a contract being awarded as a result of points claimed as shown in paragraph 6.1, the contractor may be required to furnish documentary proof to the satisfaction of the purchaser that the claims are correct;
- iv) If a bidder submitted false information regarding its evidence regarding specific goals or any other matter required in terms of the Preferential Procurement Regulations, 2022 which will affect or has affected the evaluation of a bid the purchaser may, in addition to any other remedy it may have
 - (a) disqualify the person from the bidding process;
 - (b) recover costs, losses or damages it has incurred or suffered as a result of that person’s conduct;
 - (c) cancel the contract and claim any damages which it has suffered as a result of having to make less favourable arrangements due to such cancellation;
 - (d) if the successful bidder subcontracted a portion of the bid to another person without disclosing it, Transnet reserves the right to penalise the bidder up to 10 percent of the value of the contract;
 - (e) recommend that the bidder or contractor, its shareholders and directors, or only the shareholders and directors who acted on a fraudulent basis, be restricted by the National Treasury from obtaining business from any organ of state for a period not exceeding 10 years, after the audi alteram partem (hear the other side) rule has been applied; and
 - (f) forward the matter for criminal prosecution.

WITNESSES

1.

2.

.....

SIGNATURE(S) OF BIDDERS(S)

DATE:

ADDRESS.....

SECTION 9: PROTECTION OF PERSONAL INFORMATION

1. The following terms shall bear the same meaning as contemplated in Section 1 of the Protection of Person information act, No.4 of 2013.(“POPIA”):

consent; data subject; electronic communication; information officer; operator; person; personal information; processing; record; Regulator; responsible party; special information; as well as any terms derived from these terms.
2. Transnet will process all information by the Respondent in terms of the requirements contemplated in Section 4(1) of the POPIA:

Accountability; Processing limitation; Purpose specification; Further processing limitation; Information quality; Openness; Security safeguards and Data subject participation.
3. The Parties acknowledge and agree that, in relation to personal information that will be processed pursuant to this RFP, the Responsible party is “Transnet” and the Data subject is the “Respondent”. Transnet will process personal information only with the knowledge and authorisation of the Respondent and will treat personal information which comes to its knowledge as confidential and will not disclose it, unless so required by law or subject to the exceptions contained in the POPIA.
4. Transnet reserves all the rights afforded to it by the POPIA in the processing of any of its information as contained in this RFP and the Respondent is required to comply with all prescripts as detailed in the POPIA relating to all information concerning Transnet.
5. In responding to this bid, Transnet acknowledges that it will obtain and have access to personal information of the Respondent. Transnet agrees that it shall only process the information disclosed by Respondent in their response to this bid for the purpose of evaluating and subsequent award of business and in accordance with any applicable law.
6. Transnet further agrees that in submitting any information or documentation requested in this RFP, the Respondent is consenting to the further processing of their personal information for the purpose of, but not limited to, risk assessment, assurances, contract award, contract management, auditing, legal opinions/litigations, investigations (if applicable), document storage for the legislatively required period, destruction, de-identification and publishing of personal information by Transnet and/or its authorised appointed third parties.
7. Furthermore, Transnet will not otherwise modify, amend or alter any personal data submitted by the Respondent or disclose or permit the disclosure of any personal data to any third party without the prior written consent from the Respondent. Similarly, Transnet requires the Respondent to process any personal information disclosed by Transnet in the bidding process in the same manner.
8. Transnet shall, at all times, ensure compliance with any applicable laws put in place and maintain sufficient measures, policies and systems to manage and secure against all forms of risks to any information that may be shared or accessed pursuant to this RFP (physically, through a computer or any other form of electronic communication).
9. Transnet shall notify the Respondent in writing of any unauthorised access to information, cybercrimes or suspected cybercrimes, in its knowledge and report such crimes or suspected crimes to the relevant authorities in accordance with applicable laws, after becoming aware of such crimes or suspected crime. The Respondent must take all necessary remedial steps to mitigate the extent of the loss or compromise of personal information and to restore the integrity of the affected personal information as quickly as is possible.
10. The Respondent may, in writing, request Transnet to confirm and/or make available any personal information in its possession in relation to the Respondent and if such personal information has been accessed by third parties and the identity thereof in terms of the POPIA. The Respondent may further request that Transnet correct (excluding

Respondent's Signature

Date & Company Stamp

critical/mandatory or evaluation information), delete, destroy, withdraw consent or object to the processing of any personal information relating to the Respondent in Transnet’s possession in terms of the provision of the POPIA and utilizing Form 2 of the POPIA Regulations.

- 11. In submitting any information or documentation requested in this RFP, the Respondent is hereby consenting to the processing of their personal information for the purpose of this RFP and further confirming that they are aware of their rights in terms of Section 5 of POPIA

Respondents are required to provide consent below:

YES		NO	
------------	--	-----------	--

- 12. Further, the Respondent declares that they have obtained all consents pertaining to other data subject’s personal information included in its submission and thereby indemnifying Transnet against any civil or criminal action, administrative fines or other penalty or loss that may arise as a result of the processing of any personal information that the Respondent submitted.
- 13. The Respondent declares that the personal information submitted for the purpose of this RFP is complete, accurate, not misleading, is up to date and may be updated where applicable.

Signature of Respondent’s authorised representative: _____

Should a Respondent have any complaints or objections to processing of its personal information, by Transnet, the Respondent can submit a complaint to the Information Regulator on <https://www.justice.gov.za/inforeg/>, click on contact us, click on complaints.IR@justice.gov.za

ANNEXURE A: TENDER EVALUATION METHODOLOGY

1. BACKGROUND

1.1 This document covers the evaluation methodology for the supply and delivery of OHTE Conductors for the Eastern Region.

2. REQUIREMENTS

2.1 TECHNICAL REQUIREMENTS

2.1.1 'Mandatory' - All equipment supplied shall comply with the material descriptions and/or technical specification and/or drawings to be provided to the bidder (and any other that are referenced therein provided to the bidders). Equipment technical datasheets, type test certificates, equipment and technical documents must be submitted in this regard.

2.1.2 All material shall conform to Transnet drawings & specifications and applicable SANS and IEC standards.

2.1.3 The applicable drawings, specifications and standards are indicated in the description of each item in Annexure A

2.1.4 In some cases, a single drawing may be used to specify more than one item (e.g. when an item is made from many material types). In such cases, the description must be read carefully to ensure the prices quoted are for the correct item and material type.

2.1.5 The bidder shall complete the functional evaluation for all groups of material which they intend to supply.

2.1.6 The preference is to award **all items** in a single category to a single bidder. However, only in the case where **no bidder** can provide **all items** in a group, Transnet shall evaluate each item individually **in that group only** and determine bidder rankings for each item.

2.1.7 Transnet reserves the right to split the award of the contract between more than one supplier, should it at Transnet's discretion be more advantageous in terms of, amongst others, cost or developmental considerations; Transnet is intending to split the contract per category of products required.

2.1.8 If Original Equipment Manufacturers (OEMs) intend to bid, they will not be allowed to issue Memorandum of Understandings (MOUs).

3. OHTE WIRE EVALUATION REQUIREMENTS: 100 Points

3.1 PHASE 1: 100 Points

Submission of Memorandum of Understanding (MOU)/Authorization letter (AL) OR Original Equipment Manufacturer (OEM) /Manufacturer's confirmation letter. Bidders shall pass Phase 1 to proceed to Phase 2

SUBSTANTIVE RESPONSIVENESS	WEIGHT	REQUIREMENT	SCORE (TICK)	EVIDENCE REQUIRED SUBSTANTIATING RESPONSES FAILURE TO SUBMIT THE REQUIRED EVIDENCE WILL LEAD TO A SCORE OF ZERO.
<p>MEMORANDUM OF UNDERSTANDING/ MANUFACTURER'S CONFIRMATION LETTER:</p> <p>1. If the bidder is not an OEM/Manufacturer, they shall submit a Memorandum of Understanding (MOU)/Authorization letter with the OEM/Manufacturer.</p> <ul style="list-style-type: none"> Memorandum of Understanding/Authorization letter must contain the following: 	100	Bidders to submit MoU or Authorization letter of OEM confirmation that fully complies with the substantive response notes	100 Points	MOU/Authorizations letter fully complies/OEM Confirmation letter does comply fully

<ul style="list-style-type: none"> • The MOU/approval/authorization shall be on the OEM's/Manufacturer's official letterhead. • It shall state the bidder's company name. • It shall quote the RFP number. • It shall be dated. • It shall be signed by both the manufacturer and the bidder. • It shall state the items of material in which will be manufactured. <p style="text-align: center;">OR</p> <p>2. If the bidder is the OEM for the material, they shall submit an OEM/Manufacturer's confirmation letter, which clearly states the items they are the OEM of.</p> <p>Confirmation letter must contain:</p> <ul style="list-style-type: none"> • The confirmation letter shall be on the manufacturer's official letterhead. • It shall quote the RFP number. • It shall be dated by the manufacturer. • It shall confirm that the bidder is the manufacturer of the items. • It shall state the items to be supplied. • It shall be signed by the manufacturer. <p>Bidders who do not submit the MOU/Authorization/Confirmation letters shall be disqualified for the items they did not submit for</p> <p>Note: If Original Equipment Manufacturers (OEMs) intend to bid, they will not be allowed to issue Memorandum of Understandings (MOUs).</p>			<p>0 Point</p>	<p>MoU/Authorisations/OEM Confirmation letter does not comply fully</p>
--	--	--	-----------------------	---

NOTE:

1. **Phase 1 must be passed for a respondent's proposal to progress to phase 2. Bidder(s) shall ensure that MOU meets all requirements**
2. **Bidders whom source material from different OEM shall submit an mou/confirmation letter for each different manufacturing facility they intend to source the material from, such mou shall be evaluated individually for the categories and items covered.**

3.2 PHASE 2: PREVIOUS EXPERIENCE:100 Points THRESHOLD

Submission of Proof of relevant Previous experience per category of Conductors.

Notes to bidder:

1. Bidders must submit evidence of previous supply or testing of similar items, from the previous 60 Months, in the form of:
 - a. Test certificates and inspection certificates: Should be signed or authorized by a member of the Quality Assurance Team, dated, items' descriptions clearly indicated etc.
 - b. Delivery notes: Should be stamped or signed, dated, item descriptions clearly indicated etc.
 - c. Invoices: Should be signed, dated, item descriptions clearly indicated etc.

Failure to submit this evidence will result in a score of 0 for previous experience in that group.

 Respondent's Signature

 Date & Company Stamp

1.	CRITERION	TOTAL EVALUATION CRITERIA POINTS	REQUIREMENTS	SCORE (TICK)	EVIDENCE REQUIRED SUBSTANTIATING RESPONSES. FAILURE TO SUBMIT THE REQUIRED EVIDENCE WILL LEAD TO A SCORE OF ZERO.
1.1	<p>Previous experience of similar work experience and specifications provided from the previous 5 years (60 Months).</p> <ul style="list-style-type: none"> - Inspection certificates: Should be signed or authorized by a member of the Quality Assurance Team, dated, items' descriptions clearly indicated. - Delivery notes: Should be stamped or signed, dated, items' descriptions clearly indicated. - Invoices: Should be signed, dated, items' descriptions clearly indicated. <p>Transnet reserve the right to verify documents submitted</p> <p>* The evaluation will be conducted per group of Wires</p>	100	<p>Both Inspection certificate, (1) and delivery note (1) or Invoice (1) Submitted. The proof of experience must comply with all the stipulated criteria, if it does not comply with the stipulated criteria it will result in score of 0.</p> <p>1.No Inspection certificate submitted 2.Neither delivery note or invoice Submitted 3.None of the documents submitted</p>	<p>100 Points</p> <p>0 Points</p>	<p>Bidders to submit proof of testing completed/ Inspection certificate, delivery note or invoice for the previous 5 years (60 Months)</p> <p>No proof supplied or proof submitted is outside the required period of 5 years (60 Months) or proof submitted does not comply with the stipulated criteria.</p>
<p>NOTE: PHASE 2 MUST BE PASSED FOR A RESPONDENT'S PROPOSAL TO PROGRESS PHASE 3</p>					

4. FUNCTIONAL EVALUATION: 80 POINT THRESHOLD

1. Functional evaluation 80 points threshold of 100: Bidders shall obtain a minimum of 80 points threshold, failure to meet the threshold shall result in disqualification

4.1 TECHNICAL COMPLIANCE TO SPECIFICATIONS

The functional evaluation will be conducted per group of material and will be as follows:

Notes to bidders:

1. If a bidder submits multiple MOUs per group or category, the bidder must submit drawing packs for each MOU and will be scored separately per MOU. A bidder will only progress for a category if at least one MOU meets the requirements. If progressed, the bidder will only be permitted to supply Transnet from those MOUs that have passed the evaluation.
2. Providing evidence of full compliance to Transnet's drawings or specifications as per Annexure A by submitting documentation, drawings, or datasheets from the OEM for all items in the category they are bidding for that:
 - Are labelled according to the groups and item number in the GROUP tables and Annexure A.
 - Clearly contains details that the OEM drawing or specifications comply with the given drawing, description, specifications, SANS and other standards in the item descriptions. Technical compliance to given specifications will be tested during the technical evaluation process.
 - Bidder to submit stamped or signed Transnet drawings or specifications proving compliance to given drawings or specifications, SANS and other standards in the item descriptions.

	wires) - Category B (Bonding Wire) - Category C (Droppers and Stay Wires) - Category D (Jumper and return wires) - Category E (Feeder wires) - Category F (Catenary wires) - Category G (Contact wires)				
1.2	<p>Proof of Valid ISO 9001 accreditation(s) or an ISO Quality plan(s) of the manufacturing facility/facilities that will be manufacturing the items offered by the bidder. The ISO Quality plan must consist of the following 4 stages:</p> <p>(a) The stages of inspection of material from raw material to final product. (Stage 1)</p> <p>(b) Quality assurance plan/Checklist before the material can proceed to the next stage of production (manufacturing) and who approves the final product. (Stage 2)</p> <p>(c) How the material is certified to proceed to the next stage of production. (Stage 3)</p> <p>(d) Any internal test certificates applicable to the material throughout production stages and test certificates for final product. (Stage 4)</p> <p>Evidence required substantiating responses: Bidder to provide Valid ISO9001 Certification or ISO Quality Plan. ISO 9001 certification should be issued by accredited certification bodies from the country of issue. Transnet reserve the right to verify the ISO accreditation.</p> <p>For non-OEM bidders, the quality plan(s) or ISO9001 certification(s) shall be for each of the OEM(s)/Manufacturer(s) that provided the MOU(s)/Authorization/Confirmation letter(s). If a quality plan/ISO9001 certification is submitted with no accompanying MOU/Authorization/Confirmation letter, that quality plan/ISO 9001 shall not be evaluated.</p>	50%	<p>Valid ISO9001 certificate or an ISO Quality Plan consists of all 4 stages</p> <p>ISO Quality Plan consisting of 3 of the 4 stages</p> <p>ISO Quality Plan consists of 2 of the 4 stages</p> <p>ISO Quality Plan consists of only 1 of the 4 stages</p> <p>No Quality Plan or Valid ISO certificate Submitted</p>	<p>4 points 50%</p> <p>3 points (37.5%)</p> <p>2 points (25%)</p> <p>1 point (12.5%)</p> <p>0 Point</p>	<p>Bidder to provide ISO9001 Certification or ISO Quality Plan</p>

	<p>The OEM bidders who own multiple manufacturing facilities that will be manufacturing the items must provide the quality plans or ISO 9001 certifications for each of the OEM(s)/Manufacturer(s) that provided the Confirmation Letter(s), for the facilities that will be manufacturing the material</p> <p>* The evaluation will be conducted per group of conductors.</p>														
1.3	<p>How long does it take to supply and deliver to Transnet once purchase order has been placed? (1 Week = 5 Business Days)</p> <p><u>Evidence required substantiating responses:</u></p> <p>Bidder to submit a delivery schedule letter. The delivery letter must contain the following:</p> <ul style="list-style-type: none"> • The letter shall be on the Bidder's official letter head. • It shall state the bidder's company name. • It shall quote the RFP number. • It shall be dated. • It shall be signed by the bidder. • It should clearly state the delivery lead time of items to be supplied per group. <p>* The evaluation will be conducted per group of conductors.</p>	25%	<table border="1"> <tr> <td>1. ≤ 8 Weeks</td> <td>4 points (25%)</td> </tr> <tr> <td>2. > 8 ≤ 10 Weeks</td> <td>3 points (18.75%)</td> </tr> <tr> <td>3. > 10 ≤ 12 Weeks</td> <td>2 points (12.5%)</td> </tr> <tr> <td>4. > 12 ≤ 14 Weeks</td> <td>1 point (6.25%)</td> </tr> <tr> <td>5. > 14 Weeks</td> <td>0 points (0%)</td> </tr> </table>	1. ≤ 8 Weeks	4 points (25%)	2. > 8 ≤ 10 Weeks	3 points (18.75%)	3. > 10 ≤ 12 Weeks	2 points (12.5%)	4. > 12 ≤ 14 Weeks	1 point (6.25%)	5. > 14 Weeks	0 points (0%)		<p>Bidder to:</p> <p>1. The evaluation of the delivery schedule will be based on the delivery of at least 80% of the quantities required per group.</p>
1. ≤ 8 Weeks	4 points (25%)														
2. > 8 ≤ 10 Weeks	3 points (18.75%)														
3. > 10 ≤ 12 Weeks	2 points (12.5%)														
4. > 12 ≤ 14 Weeks	1 point (6.25%)														
5. > 14 Weeks	0 points (0%)														
			<p>No delivery schedule letter supplied or the letter does not meet the six listed requirements 0 points (0%)</p>												

Notes to bidders:

1. The bidder is to use the table below as a checklist for each returnable drawing/document. This check sheet will be used during evaluation phase to check if an OEM drawing OR datasheet OR document has been returned to verify compliance to given drawings and specifications.
2. The THRESHOLD for each group is 100 Points. Failure to return requested drawings for any single item/material will result in disqualification for that entire group. Items will only be evaluated and awarded individually if the group cannot be awarded to any bidder as a whole.
3. Bidders must carefully read **all quoted descriptions, drawings, specifications, and applicable standards** and ensure that the documents submitted for each item are fully compliant for every item in each group they are bidding for.
4. The "OEM Drawing/Document/Datasheet returned?" column is to contain **ONLY a 'Yes' or 'No', along with any added information on where to locate the relevant document.**

Respondent's Signature

Date & Company Stamp

No	Item Number	Description	Standard/Specification	OEM Drawing / Document/Datasheet Returned?	Yes/No
Category A (Phase and earth wires)					
1	54039916	WIRE, ELECTRICAL; TYPE: EARTH, CONDUCTOR DIAMETER: 160 MM2, INSULATION COLOR: NONE, CONDUCTOR MATERIAL: ALUMINIUM HARD DRAWN, PACKAGE TYPE: WOOD DRUM 2 KM; SPECIFICATION: SANS182 PART2, 0; SABS182 PART2; USED ON Ohte; CODE NAME: HORNET; STRAND 19/3.25 MM	SANS 182-2		
2	54012945	WIRE, ELECTRICAL; TYPE: PHASE, CONDUCTOR DIAMETER: 50 MM2, INSULATION COLOR: NONE, DIMENSIONS: LG 2 KM, CONDUCTOR MATERIAL: ALUMINIUM, PACKAGE TYPE: REEL, WOOD; SPECIFICATION: SANS182 PART3, LA; MATERIAL NUMBER 054012945; USED ON Ohte; STEEL REINFORCED; CODE NAME: RABBIT	SANS182 PART3		
Category B (Bonding Wire)					

Respondent's Signature

Date & Company Stamp

1	54019365	WIRE, ELECTRICAL; TYPE: BONDING, CONDUCTOR DIAMETER: 97 MM2, INSULATION COLOR: BLACK, POTENTIAL RATING: 25 KV, OVERALL DIAMETER: 13 MM, CONDUCTOR MATERIAL: STEEL, CONDUCTOR FINISH: GALVANIZED, SPECIAL FEATURES: INSULATION POLYVINYL CHLORIDE/SHEATHED, PACKAGE TYPE: REEL; SPECIFICATION: SANS182 PART 5, LASANS1507 PART 3, LA; MATERIAL NUMBER 54019365, STRANDED GALVANIZED STEEL WIRE STRANDING 49/1.6MM	SANS 182-5/SANS 1507-3		
Category C (Dropper Wire and Stay Wire)					
1	54039888	WIRE; TYPE: DROPPER, DIAMETER: 4 MM, MATERIAL: STAINLESS STEEL, STRUCTURE: SOLID; SPECIFICATION: AISI GRADE 304 SOFT, LA; PACKAGE TYPE: COIL 50 KG, THE WIRE COIL MUST HAVE A DIAMETER OF 500 MM USED ON OHTE	AISI GRADE 304		
2	54012868	WIRE, ELECTRICAL; TYPE: STAY, CONDUCTOR DIAMETER: 12.2 MM2, INSULATION COLOR: NONE, DIMENSIONS: LG 300 M, CONDUCTOR MATERIAL: STEEL, CONDUCTOR FINISH: GALVANIZED, PACKAGE TYPE: REEL, WOOD; SPECIFICATION: SANS182 PART5, 0; USED ON OHTE; QUALITY: 700MPA; TENSILE STRENGTH: 61.57KN ,CONDUCTOR SIZE 12-12.2 MM2	SANS182 PART5		

3	54012881	WIRE, ELECTRICAL; TYPE: STAY, CONDUCTOR DIAMETER: 20.4 MM2, INSULATION COLOR: NONE, DIMENSIONS: LG 500 M, CONDUCTOR MATERIAL: STEEL, INSULATION MATERIAL: NON INSULATED, CONDUCTOR FINISH: GALVANIZED, PACKAGE TYPE: REEL, WOOD; USED ON OHTE; SPECIFICATION: SANS182 PART5	SANS182 PART5		
Category D (Jumper and return wires)					
1	54013016	WIRE, ELECTRICAL; TYPE: FEEDER, CONDUCTOR DIAMETER: 800 MM2, INSULATION COLOR: NONE, DIMENSIONS: 1 KM, CONDUCTOR MATERIAL: ALUMINIUM HARD DRAWN, PACKAGE TYPE: REEL, WOOD; SPECIFICATION: SANS182 PART2, 0; USED ON OHTE; CODE NAME: BULL; STRAND 61/4.25 MM	SANS 182-2		
2	54039459	WIRE, ELECTRICAL; TYPE: RETURN CONDUCTOR, CONDUCTOR DIAMETER: 250 MM2, INSULATION COLOR: NONE, DIMENSIONS: LG 2 KM, CONDUCTOR MATERIAL: ALUMINIUM HARD DRAWN, PACKAGE TYPE: REEL, WOOD; SPECIFICATION: SANS182 PART2, 0; ITEM USED ON OHTE; CODE NAME: COCKROACH; STRAND 19/4.22 MM	SANS182 PART2		
Category E (Feeder wires)					

1	54033307	WIRE, ELECTRICAL; TYPE: FEEDER, CONDUCTOR DIAMETER: 800 MM2, INSULATION COLOR: NONE, POTENTIAL RATING: 25 KV, DIMENSIONS: LG 1 KM, CONDUCTOR MATERIAL: ALUMINIUM HARD DRAWN, INSULATION MATERIAL: NONE, PACKAGE TYPE: REEL, WOOD; SPECIFICATION: SANS182 PART 3, LA; ACSR; USED ON OHTE; STEELREINFORCED; CODE NAME; LAPWING; STRAND 45/4.77 MM ALUMINIUM + 7/3.18 MM STEEL	SANS 182-3		
2	54112442	WIRE, ELECTRICAL; TYPE: JUMPER, ALL ALUMINUM CONDUCTOR, CONDUCTOR DIAMETER: 160 MM2, INSULATION COLOR: NONE, DIMENSIONS: LG 500 M, CONDUCTOR MATERIAL: ALUMINIUM, INSULATION MATERIAL: NONE, PACKAGE TYPE: REEL, WOOD; SPECIFICATION: BBH 2161, LA	BBH 2161		
Category F (Catenary wires)					
1	54011471	WIRE, ELECTRICAL; TYPE: CATENARY, CONDUCTOR DIAMETER: 80 MM2, INSULATION COLOR: NONE, POTENTIAL RATING: 25 KV, DIMENSIONS: LG 2 KM, CONDUCTOR MATERIAL: COPPER HARD DRAWN, PACKAGE TYPE: REEL, WOOD; SPECIFICATION: SANS182 PART1, 1; USED ON OHTE; STRAND 7/3.75MM	SANS 182-1		
2	54019567	WIRE, ELECTRICAL; TYPE: CATENARY, CONDUCTOR DIAMETER: 160 MM2, INSULATION COLOR: NONE, POTENTIAL RATING: 25 KV, DIMENSIONS: LG 2	SANS 182-3		

		KM, CONDUCTOR MATERIAL: ALUMINIUM HARD DRAWN, PACKAGE TYPE: REEL, WOOD; ACSR; USED ON OHTE; STEEL REINFORCED; CODE NAME: TIGER; STRAND 30/7/2.36MM			
3	54019580	WIRE, ELECTRICAL; TYPE: CATENARY, CONDUCTOR DIAMETER: 530 MM2, INSULATION COLOR: NONE, DIMENSIONS: 1 KM, CONDUCTOR MATERIAL: ALUMINIUM HARD DRAWN, PACKAGE TYPE: REEL, WOOD; SPECIFICATION: SANS182 PART3 2003, 0; ACSR; USED ON: OHTE, STEEL REINFORCED; CODE NAME: DEER ; STRAND 30/7/4.27	SANS 182-3		
4	54032767	WIRE, ELECTRICAL; TYPE: CATENARY, CONDUCTOR DIAMETER: 160 MM2, INSULATION COLOR: NONE, DIMENSIONS: 1 KM, CONDUCTOR MATERIAL: ALUMINIUM HARD DRAWN, PACKAGE TYPE: REEL, WOOD; USED ON OHTE; STEEL REINFORCED; CODE NAME: TIGER; STRAND 30/7/2.36 MM	SANS182 PART3 2003		
5	54032755	WIRE, ELECTRICAL; TYPE: CATENARY, CONDUCTOR DIAMETER: 530 MM2, INSULATION COLOR: NONE, DIMENSIONS: LG 500 M, CONDUCTOR MATERIAL: ALUMINIUM HARD DRAWN, INSULATION MATERIAL: NON INSULATED, PACKAGE TYPE: REEL, WOOD; SPECIFICATION: SANS182 PART3 , LA; ITEM USED ON: OHTE; STEEL REINFORCED; CODE NAME: DEER; STRAND 30/7/4.27	SANS182 PART3		

Category G (Contact wires)					
1	54013041	WIRE, ELECTRICAL; TYPE: CONTACT, CONDUCTOR DIAMETER: 161 MM2, INSULATION COLOR: NONE, POTENTIAL RATING: 3 KV, DIMENSIONS: LG 1.83 KM, CONDUCTOR MATERIAL: COPPER, INSULATION MATERIAL: NON INSULATED, SPECIAL FEATURES: GROOVED, PACKAGE TYPE: DRUM WOOD; SPECIFICATION: CEE.0241.2009, LA; MATERIAL NUMBER; 54013041; FOR SPOORNET USE ONLY; USED ON OHTE	CEE 0241-2009		
2	54039839	WIRE, ELECTRICAL; TYPE: CONTACT WIRE, CONDUCTOR DIAMETER: 107 MM2, INSULATION COLOR: NONE, POTENTIAL RATING: 25 KVAC, CONDUCTOR MATERIAL: COPPER, SPECIAL FEATURES: GROOVED, PACKAGE TYPE: WOODEN DRUM 1620 M; SPECIFICATION: CEE.0241.2009, LA; USED ON OHTE	CEE 0241-2009		
3	54032666	WIRE, ELECTRICAL; TYPE: CONTACT WIRE, CONDUCTOR DIAMETER: 107 MM2, INSULATION COLOR: NONE, POTENTIAL RATING: 25 KV, DIMENSIONS: LG 810 M, CONDUCTOR MATERIAL: COPPER, SPECIAL FEATURES: GROOVED, PACKAGE TYPE: WOOD DRUM; SPECIFICATION: CEE- 0241, LA; EQUIPMENT USED ON OHTE	CEE.0241		
4	54032678	WIRE, ELECTRICAL; TYPE: CONTACT, CONDUCTOR DIAMETER: 161 MM2, INSULATION COLOR: NONE, POTENTIAL RATING: 3 KV, DIMENSIONS: 915 M,	CEE.0241		

Respondent's Signature

Date & Company Stamp

		CONDUCTOR MATERIAL: COPPER, SPECIAL FEATURES: GROOVED, PACKAGE TYPE: DRUM 915 M; SPECIFICATION: CEE.0241, LA			
5	54034135	WIRE, ELECTRICAL; TYPE: CONTACT, CONDUCTOR DIAMETER: 107 MM2, INSULATION COLOR: NONE, DIMENSIONS: LG 1620 M, CONDUCTOR MATERIAL: COPPER MAGNESIUM, CONDUCTOR FINISH: MARKING THREE IDENTIFICATION GROOVES ON UPPER LOBE, PACKAGE TYPE: DRUM WOOD; SPECIFICATION: BBD 7267, LA	BBD 7267		
6	54034147	WIRE, ELECTRICAL; TYPE: CONTACT, CONDUCTOR DIAMETER: 161 MM2, INSULATION COLOR: NONE, DIMENSIONS: LG 1830 M CONDUCTOR MATERIAL: COPPER MAGNESIUM, INSULATION MATERIAL: NON INSULATED, CONDUCTOR FINISH: MARKING THREE IDENTIFICATION GROOVES ON UPPER LOBE, PACKAGE TYPE: WOODEN DRUM; SPECIFICATION: BBD 7267, LA	BBD 7267		

ANNEXURE C: LOCAL CONTENT

SATS 1286.2011												
Annex C												
MANDATORY RETURNABLE DOCUMENT: FAILURE TO FULLY COMPLETE, DECLARE, SIGN & DATE THIS ANNEXURE C WILL RESULT IN THE BID BEING NON-RESPONSIVE & DISQUALIFIED												
Local Content Declaration - Summary Schedule												
(C1)	Tender No. HOAC VAR 57488											Note: VAT to be excluded from all calculations
(C2)	Tender description: Supply and delivery of OHTE Wires as and when required for the Eastern Region for a period of 12 months											
(C3)	Designated product(s): Steel wires											
(C4)	Tender Authority: Transnet Rail Infrastructure Manager											
(C5)	Tendering Entity name:											
(C6)	Tender Exchange Rate: Pula <input type="text"/> EU <input type="text"/> GBP <input type="text"/>											
(C7)	Specified local content %											
Calculation of local content												
Tender summary												
Tender item no's	Transnet Item Numbers	List of Items	Tender price - each (excl VAT)	Exempted imported value	Tender value net of exempted imported content	Imported value	Local value	Local content % (per item)	Tender Qty	Total tender value	Total exempted imported content	Total Imported content
(C8)		(C9)	(C10)	(C11)	(C12)	(C13)	(C14)	(C15)	(C16)	(C17)	(C18)	(C19)
Category A (Phase and earth wires)												
1	54039916	WIRE, ELECTRICAL; TYPE: EARTH, CONDUCTOR DIAMETER: 160							26 000			
2	54012945	WIRE, ELECTRICAL; TYPE: PHASE, CONDUCTOR DIAMETER: 50 MM2							9 400			
									(C20) Total tender value	R		
									(C21) Total Exempt imported content	R		
									(C22) Total Tender value net of exempt imported content	R		
									(C23) Total Imported content	R		
									(C24) Total local content	R		
									(C25) Average local content % of tender			
Signature of tenderer from Annex B												
Date:												

SATS 1286.2011												
Annex C												
MANDATORY RETURNABLE DOCUMENT: FAILURE TO FULLY COMPLETE, DECLARE, SIGN & DATE THIS ANNEXURE C WILL RESULT IN THE BID BEING NON-RESPONSIVE & DISQUALIFIED												
Local Content Declaration - Summary Schedule												
(C1)	Tender No. HOAC VAR 57488											Note: VAT to be excluded from all calculations
(C2)	Tender description: Supply and delivery of OHTE Wires as and when required for the Eastern Region for a period of 12 months											
(C3)	Designated product(s): Steel wires											
(C4)	Tender Authority: Transnet Rail Infrastructure Manager											
(C5)	Tendering Entity name:											
(C6)	Tender Exchange Rate: Pula <input type="text"/> EU <input type="text"/> GBP <input type="text"/>											
(C7)	Specified local content %											
Calculation of local content												
Tender summary												
Tender item no's	Transnet Item Numbers	List of Items	Tender price - each (excl VAT)	Exempted imported value	Tender value net of exempted imported content	Imported value	Local value	Local content % (per item)	Tender Qty	Total tender value	Total exempted imported content	Total Imported content
(C8)		(C9)	(C10)	(C11)	(C12)	(C13)	(C14)	(C15)	(C16)	(C17)	(C18)	(C19)
Category B (Bonding Wire)												
1	54019365	WIRE, ELECTRICAL; TYPE: BONDING, CONDUCTOR							19 000			
									(C20) Total tender value	R		
									(C21) Total Exempt imported content	R		
									(C22) Total Tender value net of exempt imported content	R		
									(C23) Total Imported content	R		
									(C24) Total local content	R		
									(C25) Average local content % of tender			
Signature of tenderer from Annex B												
Date:												

Respondent's Signature

Date & Company Stamp

SATS 1286.2011													
Annex C													
MANDATORY RETURNABLE DOCUMENT: FAILURE TO FULLY COMPLETE, DECLARE, SIGN & DATE THIS ANNEXURE C WILL RESULT IN THE BID BEING NON-RESPONSIVE & DISQUALIFIED													
Local Content Declaration - Summary Schedule													
(C1)	Tender No.		HOAC VAR 57488										
(C2)	Tender description:		Supply and delivery of OHTE Wires as and when required for the Eastern Region for a period of 12 months										
(C3)	Designated product(s):		Steel wires										
(C4)	Tender Authority:		Transnet Rail Infrastructure Manager										
(C5)	Tendering Entity name:												
(C6)	Tender Exchange Rate:		Pula		EU			GBP			Note: VAT to be excluded from all calculations		
(C7)	Specified local content %												
			Calculation of local content						Tender summary				
	Tender item no's	Transnet Item Numbers	List of Items	Tender price - each (excl VAT)	Exempted imported value	Tender value net of exempted imported content	Imported value	Local value	Local content % (per item)	Tender Qty	Total tender value	Total exempted imported content	Total Imported content
	(C8)	(C9)	(C10)	(C11)	(C12)	(C13)	(C14)	(C15)	(C16)	(C17)	(C18)	(C19)	
Category C (Dropper Wire and Stay Wire)													
	1	54039888	WIRE, TYPE: DROPPER, DIAMETER: 4 MM, MATERIAL: STAINLESS STEEL, STRUCTURE: SOLID							2 240			
	2	54012868	WIRE, ELECTRICAL; TYPE: STAY, CONDUCTOR DIAMETER: 12.2 MM2							4 200			
	3	54012881	WIRE, ELECTRICAL; TYPE: STAY, CONDUCTOR DIAMETER: 20.4 MM2							1 000			
										(C20) Total tender value R			
										(C21) Total Exempt imported content R			
										(C22) Total Tender value net of exempt imported content R			
										(C23) Total Imported content R			
										(C24) Total local content R			
										(C25) Average local content % of tender			
Signature of tenderer from Annex B													
Date:													

SATS 1286.2011													
Annex C													
MANDATORY RETURNABLE DOCUMENT: FAILURE TO FULLY COMPLETE, DECLARE, SIGN & DATE THIS ANNEXURE C WILL RESULT IN THE BID BEING NON-RESPONSIVE & DISQUALIFIED													
Local Content Declaration - Summary Schedule													
(C1)	Tender No.		HOAC VAR 57488										
(C2)	Tender description:		Supply and delivery of OHTE Wires as and when required for the Eastern Region for a period of 12 months										
(C3)	Designated product(s):		Steel wires										
(C4)	Tender Authority:		Transnet Rail Infrastructure Manager										
(C5)	Tendering Entity name:												
(C6)	Tender Exchange Rate:		Pula		EU			GBP			Note: VAT to be excluded from all calculations		
(C7)	Specified local content %												
			Calculation of local content						Tender summary				
	Tender item no's	Transnet Item Numbers	List of Items	Tender price - each (excl VAT)	Exempted imported value	Tender value net of exempted imported content	Imported value	Local value	Local content % (per item)	Tender Qty	Total tender value	Total exempted imported content	Total Imported content
	(C8)	(C9)	(C10)	(C11)	(C12)	(C13)	(C14)	(C15)	(C16)	(C17)	(C18)	(C19)	
Category D (Jumper and return wires)													
	1	54013016	WIRE, ELECTRICAL; TYPE: FEEDER, CONDUCTOR DIAMETER: 800 MM2							20 000			
	2	54039459	WIRE, ELECTRICAL; TYPE: RETURN CONDUCTOR, CONDUCTOR DIAMETER: 250 MM2							12 000			
										(C20) Total tender value R			
										(C21) Total Exempt imported content R			
										(C22) Total Tender value net of exempt imported content R			
										(C23) Total Imported content R			
										(C24) Total local content R			
										(C25) Average local content % of tender			
Signature of tenderer from Annex B													
Date:													

SATS 1286.2011														
Annex C														
MANDATORY RETURNABLE DOCUMENT: FAILURE TO FULLY COMPLETE, DECLARE, SIGN & DATE THIS ANNEXURE C WILL RESULT IN THE BID BEING NON-RESPONSIVE & DISQUALIFIED														
Local Content Declaration - Summary Schedule														
(C1)	Tender No.		HOAC VAR 57488											
(C2)	Tender description:		Supply and delivery of OHTE Wires as and when required for the Eastern Region for a period of 12 months											
(C3)	Designated product(s):		Steel wires											
(C4)	Tender Authority:		Transnet Rail Infrastructure Manager											
(C5)	Tendering Entity name:													
(C6)	Tender Exchange Rate:		Pula		EU		GBP							
(C7)	Specified local content %													
Calculation of local content														
Tender summary														
	Tender item no's	Transnet Item Numbers	List of Items	Tender price - each (excl VAT)	Exempted imported value	Tender value net of exempted imported content	Imported value	Local value	Local content % (per item)	Tender Qty	Total tender value	Total exempted imported content	Total Imported content	
	(C8)		(C9)	(C10)	(C11)	(C12)	(C13)	(C14)	(C15)	(C16)	(C17)	(C18)	(C19)	
Category E (Feeder wires)														
	1	54033307	WIRE, ELECTRICAL; TYPE: FEEDER, CONDUCTOR DIAMETER: 800 MM2							3 000				
	2	54112442	WIRE, ELECTRICAL; TYPE: JUMPER, ALL ALUMINUM CONDUCTOR, CONDUCTOR DIAMETER: 160 MM2							48 500				
										(C20) Total tender value	R			
										(C21) Total Exempt imported content	R			
										(C22) Total Tender value net of exempt imported content	R			
										(C23) Total Imported content	R			
										(C24) Total local content	R			
										(C25) Average local content % of tender	R			
Signature of tenderer from Annex B														
Date:														

SATS 1286.2011														
Annex C														
MANDATORY RETURNABLE DOCUMENT: FAILURE TO FULLY COMPLETE, DECLARE, SIGN & DATE THIS ANNEXURE C WILL RESULT IN THE BID BEING NON-RESPONSIVE & DISQUALIFIED														
Local Content Declaration - Summary Schedule														
(C1)	Tender No.		HOAC VAR 57488											
(C2)	Tender description:		Supply and delivery of OHTE Wires as and when required for the Eastern Region for a period of 12 months											
(C3)	Designated product(s):		Steel wires											
(C4)	Tender Authority:		Transnet Rail Infrastructure Manager											
(C5)	Tendering Entity name:													
(C6)	Tender Exchange Rate:		Pula		EU		GBP							
(C7)	Specified local content %													
Calculation of local content														
Tender summary														
	Tender item no's	Transnet Item Numbers	List of Items	Tender price - each (excl VAT)	Exempted imported value	Tender value net of exempted imported content	Imported value	Local value	Local content % (per item)	Tender Qty	Total tender value	Total exempted imported content	Total Imported content	
	(C8)		(C9)	(C10)	(C11)	(C12)	(C13)	(C14)	(C15)	(C16)	(C17)	(C18)	(C19)	
Category F (Catenary wires)														
	1	54011471	WIRE, ELECTRICAL; TYPE: CATENARY, CONDUCTOR DIAMETER: 80 MM2							6 000				
	2	54019567	WIRE, ELECTRICAL; TYPE: CATENARY, CONDUCTOR DIAMETER: 160 MM2							321 740				
	3	54019580	WIRE, ELECTRICAL; TYPE: CATENARY, CONDUCTOR DIAMETER: 530 MM2							20 000				
	4	54032767	WIRE, ELECTRICAL; TYPE: CATENARY, CONDUCTOR DIAMETER: 160 MM2							80 780				
	5	54032755	WIRE, ELECTRICAL; TYPE: CATENARY, CONDUCTOR DIAMETER: 530 MM2							32 000				
										(C20) Total tender value	R			
										(C21) Total Exempt imported content	R			
										(C22) Total Tender value net of exempt imported content	R			
										(C23) Total Imported content	R			
										(C24) Total local content	R			
										(C25) Average local content % of tender	R			
Signature of tenderer from Annex B														
Date:														

SATS 1286.2011

Annex C

MANDATORY RETURNABLE DOCUMENT:
FAILURE TO FULLY COMPLETE, DECLARE, SIGN & DATE THIS ANNEXURE C WILL RESULT IN THE BID BEING NON-RESPONSIVE & DISQUALIFIED

Local Content Declaration - Summary Schedule

(C1) Tender No.	HOAC VAR 57488		
(C2) Tender description:	Supply and delivery of OHE Wires as and when required for the Eastern Region for a period of 12 months		
(C3) Designated product(s):	Steel wires		
(C4) Tender Authority:	Transnet Rail Infrastructure Manager		
(C5) Tendering Entity name:			
(C6) Tender Exchange Rate:	Pula	EU	GBP
(C7) Specified local content %			

Note: VAT to be excluded from all calculations

Tender item no's	Transnet Item Numbers	List of Items	Tender price - each (excl VAT)	Exempted imported value	Calculation of local content				Tender summary			
					Tender value net of exempted imported content	Imported value	Local value	Local content % (per item)	Tender Qty	Total tender value	Total exempted imported content	Total imported content
(C8)		(C9)	(C10)	(C11)	(C12)	(C13)	(C14)	(C15)	(C16)	(C17)	(C18)	(C19)
Category G (Contact wires)												
1	54013041	WIRE, ELECTRICAL; TYPE: CONTACT, CONDUCTOR DIAMETER: 161 MM2							79 250			
2	54039839	WIRE, ELECTRICAL; TYPE: CONTACT WIRE, CONDUCTOR DIAMETER: 107 MM2							4 860			
3	54032666	WIRE, ELECTRICAL; TYPE: CONTACT WIRE, CONDUCTOR DIAMETER: 107 MM2							810			
4	54032678	WIRE, ELECTRICAL; TYPE: CONTACT, CONDUCTOR DIAMETER: 161 MM2							915			
5	54034135	WIRE, ELECTRICAL; TYPE: CONTACT, CONDUCTOR DIAMETER: 107 MM2							71 280			

Signature of tenderer from Annex B

Date:

(C20) Total tender value	R
(C21) Total Exempt imported content	R
(C22) Total Tender value net of exempt imported content	R
(C23) Total imported content	R
(C24) Total local content	R
(C25) Average local content % of tender	

SATS 1286.2011

Annex D

ESSENTIAL RETURNABLE DOCUMENT:
FAILURE TO FULLY COMPLETE, DECLARE, SIGN & DATE THIS ANNEXURE D MAY RESULT IN THE BID BEING NON-RESPONSIVE & DISQUALIFIED

Imported Content Declaration - Supporting Schedule to Annex C

(D1) Tender No.	HOAC VAR 57488	Note: VAT to be excluded from all calculations
(D2) Tender description:	Supply and delivery of OHTE Wires as and when required for the Eastern Region for a period of 12 months	
(D3) Designated Products:	Electrical cables designated at 90%/Steel wires designated at 100%	
(D4) Tender Authority:	Transnet Rail Infrastructure Manager	
(D5) Tendering Entity name:		
(D6) Tender Exchange Rate:	Pula <input type="text"/> EU R 9,00 GBP R 12,00	

A. Exempted imported content				Calculation of imported content						Summary	
Tender item no's	Description of imported content	Local supplier	Overseas Supplier	Foreign currency value as per Commercial Invoice	Tender Exchange Rate	Local value of imports	Freight costs to port of entry	All locally incurred landing costs & duties	Total landed cost excl VAT	Tender Qty	Exempted imported value
(D7)	(D8)	(D9)	(D10)	(D11)	(D12)	(D13)	(D14)	(D15)	(D16)	(D17)	(D18)
(D19) Total exempt imported value R											

This total must correspond with Annex C - C 21

B. Imported directly by the Tenderer				Calculation of imported content						Summary	
Tender item no's	Description of imported content	Unit of measure	Overseas Supplier	Foreign currency value as per Commercial Invoice	Tender Rate of Exchange	Local value of imports	Freight costs to port of entry	All locally incurred landing costs & duties	Total landed cost excl VAT	Tender Qty	Total imported value
(D20)	(D21)	(D22)	(D23)	(D24)	(D25)	(D26)	(D27)	(D28)	(D29)	(D30)	(D31)
(D32) Total imported value by tenderer R											

C. Imported by a 3rd party and supplied to the Tenderer				Calculation of imported content						Summary	
Description of imported content	Unit of measure	Local supplier	Overseas Supplier	Foreign currency value as per Commercial Invoice	Tender Rate of Exchange	Local value of imports	Freight costs to port of entry	All locally incurred landing costs & duties	Total landed cost excl VAT	Quantity imported	Total imported value
(D33)	(D34)	(D35)	(D36)	(D37)	(D38)	(D39)	(D40)	(D41)	(D42)	(D43)	(D44)
(D45) Total imported value by 3rd party R											

D. Other foreign currency payments				Calculation of foreign currency payments		Summary of payments	
Type of payment	Local supplier making the payment	Overseas beneficiary	Foreign currency value paid	Tender Rate of Exchange	Local value of payments	Quantity of payments	Total value of payments
(D46)	(D47)	(D48)	(D49)	(D50)	(D51)	(D52)	(D53)
(D52) Total of foreign currency payments declared by tenderer and/or 3rd party							

(D53) Total of imported content & foreign currency payments - (D32), (D45) & (D52) above R

This total must correspond with Annex C - C 23

Signature of tenderer from Annex B

Date:

Respondent's Signature

Date & Company Stamp

SATS 1286.2011

Annex E

**ESSENTIAL RETURNABLE DOCUMENT:
FAILURE TO FULLY COMPLETE, DECLARE, SIGN & DATE THIS ANNEXURE E MAY RESULT IN THE BID BEING NON-RESPONSIVE & DISQUALIFIED**

Local Content Declaration - Supporting Schedule to Annex C

(E1)	Tender No.	HOAC VAR 57488	Note: VAT to be excluded from all calculations
(E2)	Tender description:	Supply and delivery of OHTE Wires as and when required for the Eastern Region for a period of 12 months	
(E3)	Designated products:	Electrical cables designated at 90%/Steel wires designated at 100%	
(E4)	Tender Authority:	Transnet Rail Infrastructure Manager	
(E5)	Tendering Entity name:		

Local Products (Goods, Services and Works)	Description of items purchased (E6)	Local suppliers (E7)	Value (E8)
(E9) Total local products (Goods, Services and Works)			R

(E10) **Manpower costs** (Tenderer's manpower cost) R

(E11) **Factory overheads** (Rental, depreciation & amortisation, utility costs, consumables etc.) R

(E12) **Administration overheads and mark-up** (Marketing, insurance, financing, interest etc.) R

(E13) Total local content R

This total must correspond with Annex C - C24

Signature of tenderer from Annex B

Date: _____

ANNEXURE B: SPECIFICATION AND DRAWINGS

QUALITY ASSURANCE AND MANUFACTURING REQUIREMENTS (POST-AWARD)

- All materials shall be subjected to final inspection by Transnet Freight Rail’s Technology Management at the manufacturing facility prior to delivery.
- The material shall be as per provided drawings and specifications as well as the referenced SANS and IEC standards.
- No material made from malleable iron or pig iron is acceptable.
- Transnet reserves the right to do tests and quality assurance on material to be supplied. The material will be tested at the manufacturing facility before delivery.

Item Number	Standard / Specification
54039916	SANS 182-2
54012945	SANS182 PART3
54019365	SANS 182-5/SANS 1507-3
54039888	AISI GRADE 304
54012868	SANS182 PART5
54012881	SANS182 PART5
54013016	SANS 182-2
54039459	SANS182 PART2
54033307	SANS 182-3
54112442	BBH 2161
54011471	SANS 182-1
54019567	SANS 182-3
54019580	SANS 182-3
54032767	SANS182 PART3 2003
54032755	SANS182 PART3
54013041	CEE 0241-2009
54039839	CEE 0241-2009
54032666	CEE.0241
54032678	CEE.0241
54034135	BBD 7267
54034147	BBD 7267



TRANSNET
freight rail

A Division of Transnet SOC Limited

TECHNOLOGY MANAGEMENT

SPECIFICATION

SPECIFICATION FOR GROOVED, COPPER-MAGNESIUM CONTACT WIRE, FOR ELECTRICAL TRACTION PURPOSES.

Author: Technician in Training
Section: Technology Management

N.C Mokhomo

Approved: Senior Engineer
Section: Technology Management

L.O. Borchard

Authorised: Principal Engineer
Section: Technology Management

S.E Sibande

Date: 04 March 2016

Circulation Restricted To:

Transnet Freight Rail
Transnet and Relevant Third Parties
Unrestricted

© This document as a whole is protected by copyright. The information herein is the sole property of Transnet Ltd. It may not be used, disclosed or reproduced in part or in whole in any manner whatsoever, except with the written permission of and in a manner permitted by the proprietors.

"I acknowledge that this application contains personal information as defined in the Protection of Personal Information Act, 2013 (the "Act"). By accessing/using this application, I consent to the processing of my personal information in accordance with the requirements of the Act. I acknowledge that I cannot unreasonably withhold my consent. I acknowledge that the purpose for processing my personal information is in terms of this application."

INDEX

SECTION	CONTENTS	PAGE
1.0	SCOPE	3
2.0	REFERENCES	3
3.0	APPENDICES	3
4.0	METHOD OF TENDERING	3
5.0	MATERIAL	3
6.0	MARKING	4
7.0	SIZE AND LENGTH	4
8.0	DRUMS AND WINDING	4
9.0	MARKING OF DRUMS	4
10.0	INFORMATION	5
11.0	TESTS	5
12.0	APPENDIX 1	6
13.0	APPENDIX 2	7
14.0	APPENDIX 3	8
15.0	APPENDIX 4	9

1.0 SCOPE

This specification covers Transnet's requirements for the manufacture, testing and supply of grooved, 107 mm² or 161 mm² copper-magnesium (CuMg_{0,2}) contact wire.

2.0 REFERENCES

2.1 The following specification and drawing are referred to herein:

2.1.1 British Standards Specification:

BS EN 50149 : Railway application – Fixed installation – Electrical traction – Copper and copper alloy grooved contact wires

2.1.2 Transnet Drawing:

BBD 7973 : Wooden cable drum for 107 & 161 mm² contact wire.

3.0 APPENDICES

The following appendices form an integral part of this specification:

3.1 Appendix 1: Cross-sectional profile of the 107 mm² or 161 mm² contact wire.

3.2 Appendix 2: Special Marking for Identification Purposes.

(A) Specifies the nature of the imprinting

(B) Identification grooves, text size and position.

3.3 Appendix 3: Test Results of 107 mm² Grooved Contact Wire.

This appendix specifies the form in which the test results for 107 mm² grooved copper will be presented in order to check compliance.

3.4 Appendix 4: Test Results of 161 mm² Grooved Contact Wire.

This appendix specifies the form in which the test results for 161 mm² grooved Copper will be presented in order to check compliance.

4.0 METHOD OF TENDERING

4.1 Tenderers shall indicate clause by clause compliance or non-compliance with this specification. This shall take the form of a separate document listing all the specification clause numbers indicating the individual statement of compliance or non-compliance.

4.2 A statement of non-compliance shall be motivated by the tenderer.

4.2.1 The test results (Appendix 3 and 4) to this specification shall be fully completed by the tenderers.

4.2.2 Failure to comply with clauses 4.1, 4.2 and 4.3 may preclude a tender from further Consideration.

5.0 MATERIAL

5.1 The wire shall be made from high conductivity copper-magnesium CuMg_{0,2}, in accordance with specification BS EN 50149. The configuration and cross-sectional areas are depicted in Appendix 1.

5.2 The wire shall comply with all the properties detailed in Appendix 3 and 4 hereof for 107 mm² or 161 mm² respectively.



A Division of Transnet Limited

TECHNOLOGY MANAGEMENT

SPECIFICATION

SPECIFICATION FOR HARD DRAWN, GROOVED, COPPER CONTACT WIRE, FOR ELECTRICAL TRACTION PURPOSES

Author: Chief Engineering Technician

Section: Technology
Management

W.F. MANS

Approved:

Senior Engineer
Section: Technology
Management

L.O. BORCHARD

Authorised:

Principal Engineer
Section: Technology
Management

W.A. COETZEE

Date: 9 December 2009

Circulation Restricted To:

Engineering & Technology: Infrastructure Maintenance

Engineering & Technology: Infrastructure Engineering

Engineering & Technology: Technology Management

© This document as a whole is protected by copyright. The information herein is the sole property of Transnet Ltd. It may not be used, disclosed or reproduced in part or in whole in any manner whatsoever, except with the written permission of and in a manner permitted by the proprietors.

INDEX

SECTION	CONTENTS	PAGE
1.0	SCOPE	3
2.0	REFERENCES	3
3.0	APPENDICES	3
4.0	METHOD OF TENDERING	3
5.0	MATERIAL	3
6.0	MARKING	3
7.0	SIZE AND LENGTH	4
8.0	DRUMS AND WINDING	4
9.0	MARKING OF DRUMS	4
10.0	INFORMATION	4
11.0	TESTS	5

1.0 SCOPE

This specification covers Transnet's requirements for the manufacture, testing and supply of 107mm² and/or 161mm² hard drawn, grooved, copper contact wire.

2.0 REFERENCES

2.1 The following specification and drawing are referred to herein:

2.1.1 British Standards Specification:

BS EN 50149 : Railway application – Fixed installation – Electrical traction – Copper and copper alloy grooved contact wires

2.1.2 Transnet Drawing:

CEE-TW-433 : Steel Drum for Contact Wire.

3.0 APPENDICES

The following appendices form an integral part of this specification:

3.1 Appendix 1: Cross-sectional profile of the 107mm² and 161mm² contact wire.

3.2 Appendix 2: Special Marking for Identification Purposes.

(A) specifies chemical composition of the brass insertion

(B) specifies the nature of the imprinting

3.3 Appendix 3: Test Results of 107mm² Grooved Contact Wire.

This appendix specifies the form in which the test results for 107mm² grooved copper will be presented in order to check compliance.

3.4 Appendix 4: Test Results of 161mm² Grooved Contact Wire.

This appendix specifies the form in which the test results for 161mm² grooved copper will be presented in order to check compliance.

4.0 METHOD OF TENDERING

4.1 Tenderers shall indicate clause by clause compliance or non-compliance with the specification. This shall take the form of a separate document listing all the specification clause numbers indicating the individual statement of compliance or non-compliance.

4.2 A statement of non-compliance shall be motivated by the tenderer.

4.3 The test results (Appendix 2A, 3 and 4) to this specification, shall be fully completed by Tenderers.

4.4 Failure to comply to clauses 4.1, 4.2 and 4.3 may preclude a tender from further consideration.

5.0 MATERIAL

5.1 The wire shall be made from high conductivity hard drawn copper in accordance with specification BS EN 50149.

5.2 The wire shall comply with all the properties detailed in Appendix 3 and 4 hereof for 107mm² and 161mm² respectively.

6.0 MARKING

6.1 A marking groove shall be in accordance with Appendix 2(C). The groove will also comply with the following requirement.

- 6.1.1 A brass strip of cross sectional area not greater than 1% and not smaller than 0,5% of total wire area will be embedded into a groove in such a way that the removal of the brass is not possible by hand.
- 6.2 The wire shall have imprinted on the top of the lobe the words TRANSNET, as indicated in Appendix 2(B).

7.0 SIZE AND LENGTH

- 7.1 The wire shall have a cross sectional area of 107mm² or 161mm² and shall have dimensions in accordance with drawings shown in Appendix 2(A).
- 7.2 The 107mm² wire shall be supplied in continuous lengths of 1610m plus 2m minus 0 (zero) and the 161mm² wire shall be supplied in continuous lengths of 1830m plus 2m minus 0 (zero).

8.0 DRUMS AND WINDING

- 8.1 Each drum shall be manufactured in accordance with Transnet's drawing No. CEE-TW-433 and shall have the wire tightly and evenly wound thereon.
- 8.2 The inner end of each length shall be marked at a distance of 30m from that end in such a manner as to give an observer, 6m away from the drum, an indication of the approaching end of the length when the wire is being reeled off at the rate of 60m per minute.
- 8.3 The wire shall be wound on the drum with the vertical axis of the wire at right angles to the axis of the drum and in such a manner that the contact surface of the wire shall be to the bottom when the wire is unreel of the top of the drum. The wire shall be wound in uniform layers with turns tightly together and free from kinks and crossovers.
- 8.4 Both ends of the wire must be securely fixed to the drum flange.

9.0 MARKING OF DRUMS

- 9.1 Each drum shall have, clearly marked on the outer surface of one flange, the following information:
- The manufacturer's name
 - The size of the wire
 - The total length of the wire contained thereon
 - The gross mass
 - The net mass
 - Transnet's stores order number
 - A suitable sequence number for identification purposes
- 9.2 Arrows indicating the direction of un-winding, must appear clearly marked on both flanges of the drum.

10.0 INFORMATION

Tenderers shall submit with their tenders the following information:

- * Maximum resistance of the wire to be supplied, (Ω /km at 20 °C)
- * Minimum tensile strength of the wire to be supplied (kN)
- * Actual number and full details of the type of joints in each length of wire to be supplied
- * Chemical composition of brass used in embedded strip

11.0 TESTS

- 11.1 A sample length of wire from the end of each drum shall be cut off for test purposes. When relevant, one sample length in five shall include a joint. All samples shall be tested to ensure compliance with clauses 5.2, 6.1.1 and 7.1 hereof. Whenever samples cut off in terms of the above, includes a joint, the exact location of this joint shall be clearly and positively marked by means of non destructive chemical etching. This is required to ensure that the wire at the joints can be tested for compliance with the requirements of clause 5.2.
- 11.1.1 After removal of a sample length of wire from a drum, the actual length of wire remaining thereon, shall not be less than that called for in clause 7.2.
- 11.2 Since creep of the contact wire has to be taken into account during erection stages and afterwards during normal maintenance, tenderers must give figures indicating the initial and final creep rate that can be expected. The tensile stress for these creep rates should also be indicated.
- 11.3 Tests to confirm the compliance of the wire with the technical properties laid down in clause 5.2, shall be carried out on the sample lengths by the manufacturer as detailed in specification BS EN 50149.
- 11.4 Transnet reserves the right to witness all tests.
- 11.5 Copies of test certificates giving details of all tests results are to be handed, immediately after the tests, to Transnet, to confirm that the wire and drums meet the electrical and mechanical properties required by this specification.
- 11.5.1 The test certificates to be supplied to Transnet shall be as shown in Appendix 3 and 4.

SPECIAL MARKING FOR IDENTIFICATION PURPOSES

(A)

Customer's Name: _____

Customer's Order No.: _____

Drum No.: _____

Date: _____

Chemical composition of contaminant insert

Cu	
Sn	
Pb	
Fe	
Al	
Mn	
Ni	
Sb	
As	
Pb	
Si	
Cd	
Zn	
Impurity	

SPECIAL MARKING FOR IDENTIFICATION PURPOSES

(B)

 107mm^2 Contact wire 161mm^2 Contact wire

In both cases (107mm^2 and 161mm^2 contact wire) the height of the text must be $3.5\text{mm} \pm 0.5$

(C)

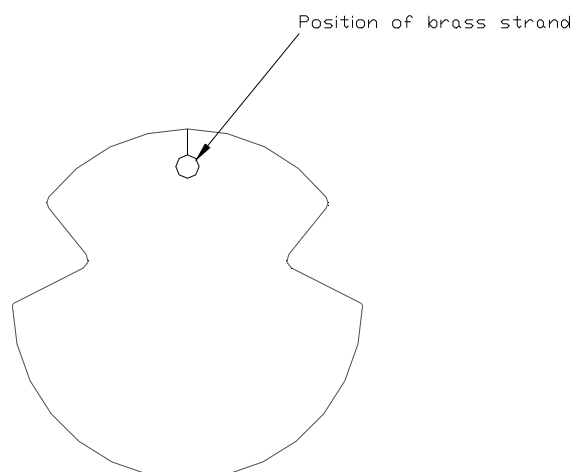

TEST RESULTS OF 107mm² GROOVED CONTACT WIRE

Customer's Name: _____

Customers Order No.: _____

Drum No.	Nominal Mass per km (kg)	Area (mm ²)	Resistance per km @ 20°C	Tensile strength (Mpa)	Elongation on 200 mm (%)	Hardness (Brinell or Rockwell)	Twists in 250 mm	Reverse Bends	Notes
	951 ±3%	107	0.1695 max	36 min	3.0 min	96 HB 1/10 or 54 HRB min	5 min	5 min	

Signed: Quality Inspector: _____ Date: _____

Testing Authority: _____ Date: _____

TEST RESULTS OF 161mm² GROOVED CONTACT WIRE

Customer's Name: _____

Customers Order No.: _____

Drum No.	Nominal Mass per km (kg)	Area (mm ²)	Resistance per km @ 20°C	Tensile strength (Mpa)	Elongation on 200 mm (%)	Hardness (Brinell or Rockwell)	Twists in 250 mm	Reverse Bends	Notes
	1430 ±3%	161	0.1125 max	32.5 min	3.0 min	96 HB 1/10 or 54 HRB min	5 min	5 min	

Signed: Quality Inspector: _____ Date: _____

Testing Authority: _____ Date: _____

6.0 MARKING

- 6.1 The wire shall have imprinted on the upper lobe of the wire the words TRANSNET as indicated in Appendix 2(A).
- 6.2 Copper-magnesium wire shall incorporate three identification grooves on the upper lobe of the wire in accordance with Appendix 2(B). These grooves will identify the copper-alloy in accordance with specification BS EN 50149.

7.0 SIZE AND LENGTH

- 7.1 The wire shall have a cross sectional area of 107 mm² or 161 mm² and shall have dimensions in accordance with Appendix 1.
- 7.2 The 107 mm² wire shall be supplied in continuous lengths of 1620 meter [(plus 2 m minus 0 (zero))] and the 161 mm² wire shall be supplied in continuous lengths of 1830 meter [(plus 2 m minus 0 (zero))].

8.0 DRUMS AND WINDING

- 8.1 Each drum shall be manufactured in accordance with Transnet's drawing No. BBD 7973 and shall have the wire tightly and evenly wound thereon.
- 8.2 The inner end of each length shall be marked at a distance of 30m from that end in such a manner as to give an observer, 6 m away from the drum, an indication of the approaching end of the length when the wire is being reeled off at the rate of 60 m per minute.
- 8.3 The wire shall be wound on the drum with the vertical axis of the wire at right angles to the axis of the drum and in such a manner that the contact surface of the wire shall be to the bottom when the wire is unreeled of the top of the drum. The wire shall be wound in uniform layers with turns tightly together and free from kinks and crossovers.
- 8.4 Both ends of the wire must be securely fixed to the drum flange.

9.0 MARKING OF DRUMS

- 9.1 Each drum shall have, clearly marked on the outer surface of one flange, the following information:
- The manufacturer's name
 - The size of the wire
 - The total length of the wire contained thereon
 - The gross mass
 - The net mass
 - Transnet's stores order number
 - A suitable sequence number for identification purposes
- 9.2 Arrows indicating the direction of un-winding, must appear clearly marked on both flanges of the drum.

10.0 INFORMATION

Tenderers shall submit with their tenders the following information:

- Maximum resistance of the wire to be supplied, (Ω/km at 20 °C)
- Minimum tensile strength of the wire to be supplied (kN)
- Actual number and full details of the type of joints in each length of wire to be supplied

11.0 TESTS

- 11.1 A sample length of wire from the end of each drum shall be cut off for test purposes. When relevant, one sample length in five shall include a joint. All samples shall be tested to ensure compliance with clauses 5.2 and 7.1 hereof. Whenever samples cut off in terms of the above, includes a joint, the exact location of this joint shall be clearly and positively marked by means of non destructive chemical etching. This is required to ensure that the wire at the joints can be tested for compliance with the requirements of clause 5.2.
- 11.1.1 After removal of a sample length of wire from a drum, the actual length of wire remaining thereon shall not be less than that called for in clause 7.2.
- 11.2 Since creep of the contact wire has to be taken into account during erection stages and afterwards during normal maintenance, tenderers must give figures indicating the initial and final creep rate that can be expected. The tensile stress for these creep rates should also be indicated.
- 11.3 Tests to confirm the compliance of the wire with the technical properties laid down in clause 5.2, shall be carried out on the sample lengths by the manufacturer as detailed in specification BS EN 50149.
- 11.4 Transnet reserves the right to witness all tests.
- 11.5 Copies of test certificates giving details of all tests results are to be handed, immediately after the tests, to Transnet, to confirm that the wire and drums meet the electrical and mechanical properties required by this specification.
- 11.5.1 The test certificates to be supplied to Transnet shall be as shown in Appendix 3 and 4.

CROSS-SECTIONAL PROFILES

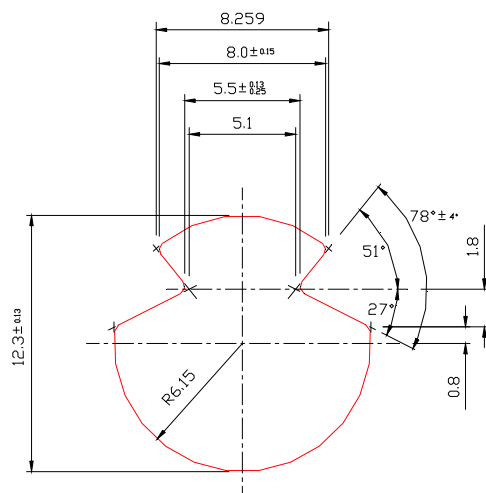

Figure 1: Cross-sectional profile of a 107 mm² Contact wire.

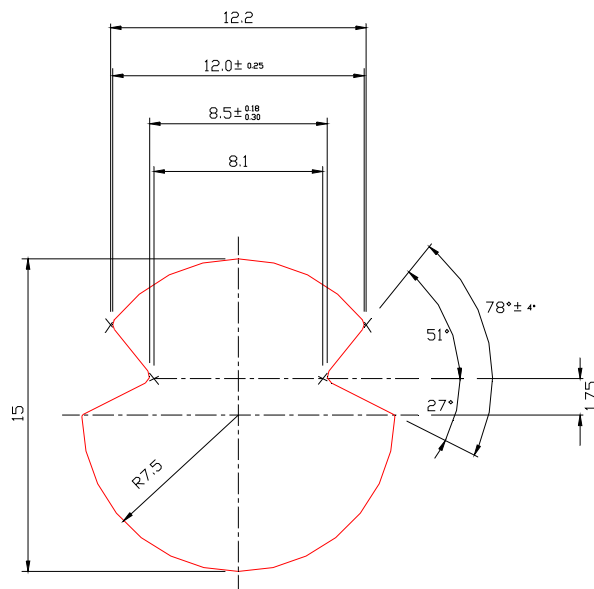
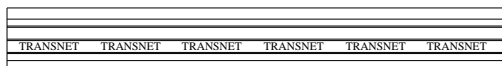

Figure 2: Cross-sectional profile of a 161 mm² Contact wire.

APPENDIX 2

SPECIAL MARKING FOR IDENTIFICATION PURPOSES

(A)



107mm² Contact wire

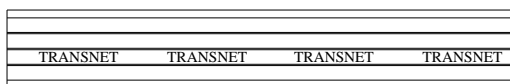

161mm² Contact wire

In both cases (107 mm² and 161 mm² contact wire) the height of the text must be as indicated below.

(B)

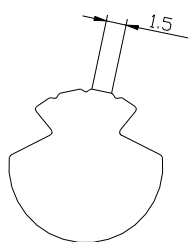

107 mm²

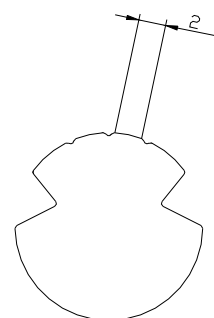

161 mm²

(Illustration not to scale)
Identification grooves, Text size and position.

APPENDIX 3

TEST RESULTS OF 107mm² GROOVED CONTACT WIRE

Customer's Name: _____

Customers Order No.: _____

Drum No.	Nominal Mass per km (kg)	Area (mm ²)	Resistance per km @ 20°C	Tensile strength N/mm ²	Elongation on 200 mm (%)	Twists in 250 mm	Reverse Bends	Notes
	951±3%	107	0.216 max	440 min	3.0 min	5 min	6 min	

Signed: Quality Inspector: _____ Date: _____

Testing Authority: _____ Date: _____

APPENDIX 4

TEST RESULTS OF 161mm² GROOVED CONTACT WIRE

Customer's Name: _____

Customers Order No.: _____

Drum No.	Nominal Mass per km (kg)	Area (mm ²)	Resistance per km @ 20°C	Tensile strength N/mm ²	Elongation on 200 mm (%)	Twists in 250 mm	Reverse Bends	Notes
	1432 ±3%	161	0.138 max	420 min	3.0 min	5 min	6 min	

Signed: Quality Inspector: _____ Date: _____

Testing Authority: _____ Date: _____



ANNEXURE C

MASTER AGREEMENT

entered into by and between

TRANSNET SOC LTD

and

.....

**FOR THE SUPPLY AND DELIVERY OF OHTE WIRES AS AND WHEN
REQUIRED FOR THE EASTERN REGION FOR A PERIOD OF 12 MONTHS**

Agreement Number **HOAC VAR 57488**

Commencement Date

Expiry Date

TABLE OF CONTENTS

1 INTRODUCTION.....3
2 DEFINITIONS3
3 INTERPRETATION6
4 NATURE AND SCOPE6
5 AUTHORITY OF PARTIES7
6 DURATION/TERM AND CANCELLATION.....7
7 RISK MANAGEMENT8
8 TRANSNET’S OBLIGATIONS8
9 GENERAL OBLIGATIONS OF THE SUPPLIER/SERVICE PROVIDER8
11 SUBCONTRACTING..... 10
12 PAYMENT TO SUB-CONTRACTORS 11
13 B-BBEE AND SOCIO-ECONOMIC OBLIGATIONS 11
17 PENALTIES 12
19 INVOICES AND PAYMENT 12
20 PRICE ADJUSTMENTS..... 13
21 WARRANTIES APPLICABLE TO GOODS..... 14
23 THIRD PARTY INDEMNITY 14
24 INSPECTION APPLICABLE TO GOODS 14
25 DEFECTIVE GOODS 15
26 TOTAL OR PARTIAL FAILURE TO PERFORM..... 16
27 NON CONFORMANCE OF GOODS/SERVICES PROCURED..... 16
28 RIGHTS ON CANCELLATION..... 17
29 BREACH AND TERMINATION..... 17
30 CESSIONS AND ASSIGNMENTS AS PER NT INSTRUCTION NOTE 08 OF 2022/2023..... 18
31 FORCE MAJEURE..... 18
32 PROTECTION OF PERSONAL INFORMATION..... 19
33 CONFIDENTIALITY 21
34 INSURANCES 22
35 LIMITATION OF LIABILITY..... 23
36 INTELLECTUAL PROPERTY RIGHTS 24
37 NON-WAIVER 26
38 PARTIAL INVALIDITY 26
39 DISPUTE RESOLUTION 26
40 ADDRESSES FOR NOTICES 26
41 WHOLE AND ONLY AGREEMENT..... 27
42 AMENDMENT AND CHANGE CONTROL..... 28
43 GENERAL..... 28
44 DATABASE OF RESTRICTED SUPPLIER..... 28

SCHEDULE 1 – WORK ORDER / SCHEDULE OF REQUIREMENTS

Supply and delivery of OHTE wires as and when required for the Eastern Region for a period of 12 months

1 INTRODUCTION

This Agreement is entered into by and between:

Transnet SOC Ltd [Registration Number 1990/000900/30] whose registered address is , Republic of South Africa [**Transnet**]

and

..... [Registration Number] whose registered address is [**the Supplier**].

NOW THEREFORE, IT IS AGREED:

- 1.1 Transnet hereby appoints the Supplier to provide, and Transnet undertakes to accept the supply of Goods / provision of Services provided for herein, as formally agreed between the Parties and in accordance with the Schedule of Requirements / Work Orders issued as a schedule to this Agreement; and
- 1.2 the Supplier hereby undertakes to provide the Goods/Services provided for herein, as formally agreed between the Parties and in accordance with the Schedule of Requirements issued as a schedule to this Agreement.

2 DEFINITIONS

Where the following words or phrases are used in this Agreement, such words or phrases shall have the meaning assigned thereto in this clause, except where the context clearly requires otherwise:

- 2.1 **AFSA** means the Arbitration Foundation of South Africa;
- 2.2 **Agreement** means this Agreement and its associated schedules and/or annexures and/or appendices, and/or schedules, including the Schedule of Requirements/Work Orders, the technical specifications for the Goods/Services and such special conditions as shall apply to this Agreement, together with the General Tender Conditions and any additional provisions in the associated bid documents tendered by the Supplier [as agreed, in writing, between the Parties], which collectively and exclusively govern the supply of Goods and provision of ancillary Services by the Supplier to Transnet;
- 2.3 **Assignment** refers to the transfer of rights and obligations in a contract from an assigner to an assignee.
- 2.4 **Background Intellectual Property** means all Intellectual Property introduced and required by either Party to give effect to their obligations under this Agreement owned in whole or in part by or licensed to either Party or their affiliates prior to the Commencement Date or developed after the Commencement Date otherwise pursuant to this Agreement;
- 2.5 **Business Day(s)** means Mondays to Fridays between 07:30 and 16:00, excluding public holidays as proclaimed in South Africa;
- 2.6 **Cession** refers to the transfer of only the rights a service provider has in terms of a contract from it to a third party.
- 2.7 **Commencement Date** means, notwithstanding the signature date of this Agreement;

Supply and delivery of OHTE wires as and when required for the Eastern Region for a period of 12 months

2.8 **Confidential Information** means any information or other data, whether in written, oral, graphic or in any other form such as in documents, papers, memoranda, correspondence, notebooks, reports, drawings, diagrams, discs, articles, samples, test results, prototypes, designs, plans, formulae, patents, or inventor's certificates, which a Party discloses or provides to the other Party [intentionally or unintentionally, or as a result of one Party permitting the representative of the other Party to visit any of its premises], or which otherwise becomes known to a Party, and which is not in the public domain and includes, without limiting the generality of the term:

- a) information relating to methods of operation, data and plans of the disclosing Party;
- b) the contents of this Agreement;
- c) private and personal details of employees or clients of the disclosing Party or any other person where an onus rests on the disclosing Party to maintain the confidentiality of such information;
- d) any information disclosed by either Party and which is clearly marked as being confidential or secret;
- e) information relating to the strategic objectives and planning of the disclosing Party relating to its existing and planned future business activities;
- f) information relating to the past, present and future research and development of the disclosing Party;
- g) information relating to the business activities, business relationships, products, services, customers, clients and Subcontractors of the disclosing Party where an onus rests on the disclosing Party to maintain the confidentiality of such information;
- h) information contained in the software and associated material and documentation belonging to the disclosing Party;
- i) technical and scientific information, Know-How and trade secrets of a disclosing Party including inventions, applications and processes;
- j) Copyright works;
- k) commercial, financial and marketing information;
- l) data concerning architecture, demonstrations, tools and techniques, processes, machinery and equipment of the disclosing Party;
- m) plans, designs, concepts, drawings, functional and technical requirements and specifications of the disclosing Party;
- n) information concerning faults or defects in Goods, equipment, hardware or software or the incidence of such faults or defects; and
- o) information concerning the charges, fees and/or costs of the disclosing Party or its authorised Subcontractors, or their methods, practices or service performance levels actually achieved;

2.9 **Copyright** means the right in expressions, procedures, methods of operations or mathematical concepts, computer program codes, compilations of data or other material, literary works, musical works, artistic works, sound recordings, broadcasts, program carrying signals, published editions, photographic works, or cinematographic works of the copyright owner to do or to authorise the doing of certain acts specified in respect of the different categories of works;

Supply and delivery of OHTE wires as and when required for the Eastern Region for a period of 12 months

- 2.10 **Data** means all data, databases, documents, information, graphics, text or other material in an electronic or tangible medium which the Parties to this Agreement generate, collect, process, store or transmit in relation to their business;
- 2.11 **Designs** mean registered Designs and/or Design applications and will include the monopoly right granted for the protection of an independently created industrial design including designs dictated essentially by technical or functional considerations as well as topographies of integrated circuits and integrated circuits;
- 2.12 **Expiry Date** means
- 2.13 **Foreground Intellectual Property** means all Intellectual Property developed by either Party pursuant to this Agreement;
- 2.14 **Goods** means, the material / products specified in the Schedule of Requirements appended as Schedule 1 hereto;
- 2.15 **ICC Incoterms** means the the latest version of commercial trade terms as published by the International Chamber of Commerce, Paris [ICC], which are otherwise referred to as purchase terms and which define precisely the responsibilities, costs and risks of the buyer [**Transnet**] and the seller [**the Supplier**]. Incoterms are only applicable to contracts involving the import or export of Goods from one country to another and for the purpose of this Agreement, if applicable, shall mean the designated Incoterm as stipulated in Schedule 1 hereto. Further details of the Incoterm [purchase terms] for this Agreement, if applicable, can be viewed at the International Business Training website - <http://www.i-b-t.net/incoterms.html>;
- 2.16 **Intellectual Property** means Patents, Designs, Know-How, Copyright and Trade Marks and all rights having equivalent or similar effect which may exist anywhere in the world and includes all future additions and improvements to the Intellectual Property;
- 2.17 **Know-How** means all Confidential Information of whatever nature relating to the Intellectual Property and its exploitation as well as all other Confidential Information generally relating to Transnet's field of technology, including technical information, processing or manufacturing techniques, Designs, specifications, formulae, systems, processes, information concerning materials and marketing and business information in general;
- 2.18 **Parties** mean the Parties to this Agreement together with their subsidiaries, divisions, business units, successors-in-title and assigns;
- 2.19 **Party** means either one of these Parties;
- 2.20 **Patents** mean registered Patents and Patent applications, once the latter have proceeded to grant, and includes a right granted for any inventions, products or processes in all fields of technology;
- 2.21 **Permitted Purpose** means any activity or process to be undertaken or supervised by a Staff member of one Party during the term of this Agreement, for which purpose authorised disclosure of the other Party's Confidential Information or Intellectual Property is a prerequisite in order to enable such activity or process to be accomplished;
- 2.22 **Price(s)** means the agreed Price(s) for the Goods/Services to be purchased from the Supplier/Service Provider by Transnet, as detailed in the Schedule of Requirements, issued in accordance with this Agreement, as amended by mutual agreement between the Parties and in accordance with the terms and conditions in this Agreement from time to time;

Supply and delivery of OHTE wires as and when required for the Eastern Region for a period of 12 months

- 2.23 **Purchase Order(s)** means official orders issued by an operating division of Transnet to the Supplier/Service Provider for the supply of Goods or Services;
- 2.24 **Service Level Agreement** or **SLA** means the processes, deliverables, key performance indicators and performance standards relating to the Goods to be provided by the Supplier;
- 2.25 **Staff** means any partner, employee, agent, consultant, independent associate or contractor, Subcontractor and the staff of such Subcontractor, or other authorised representative of either Party;
- 2.26 **Schedule of Requirements** means Schedule 1 hereto;
- 2.27 **Subcontract** means any contract or agreement or proposed contract or agreement between the Supplier/Service Provider and any third party whereby that third party agrees to provide to the Supplier the Goods or related Services or any part thereof or material used in the manufacture of the Goods or any part thereof;
- 2.28 **Subcontractor** means the third party with whom the Supplier/Service Provider enters into a Subcontract;
- 2.29 **Tax Invoice** means the document as required by Section 20 of the VAT Act, as may be amended from time to time;
- 2.30 **Trade Marks** mean registered Trade Marks and Trade Mark applications and include any sign or logo, or combination of signs and/or logos capable of distinguishing the goods or services of one undertaking from those of another undertaking;
- 2.31 **VAT** means Value-Added Tax chargeable in terms of the VAT Act, 89 of 1991, as may be amended from time to time; and
- 2.32 **VAT Act** means the Value Added Tax Act, No 89 of 1991, as may be amended from time to time.

3 INTERPRETATION

- 3.1 Clause headings in this Agreement are included for ease of reference only and do not form part of this Agreement for the purposes of interpretation or for any other purpose. No provision shall be construed against or interpreted to the disadvantage of either Party hereto by reason of such Party having or being deemed to have structured or drafted such provision.
- 3.2 Any term, word or phrase used in this Agreement, other than those defined under the clause heading "*Definitions*" shall be given its plain English meaning, and those terms, words, acronyms, and phrases used in this Agreement will be interpreted in accordance with the generally accepted meanings accorded thereto.
- 3.3 A reference to the singular incorporates a reference to the plural and *vice versa*.
- 3.4 A reference to natural persons incorporates a reference to legal persons and *vice versa*.
- 3.5 A reference to a particular gender incorporates a reference to the other gender.

4 NATURE AND SCOPE

- 4.1 This Agreement is an agreement under the terms and conditions of which the Supplier/Service Provider will arrange for the supply/provision to Transnet of the Goods/Services which meet the requirements and specifications of Transnet, the delivery of which is controlled by means of Purchase Orders to be issued by Transnet and executed by the Supplier/Service Provider in accordance with this Agreement.

Supply and delivery of OHTE wires as and when required for the Eastern Region for a period of 12 months

- 4.2 Such Purchase Orders and deliveries to Transnet shall be agreed between the Parties from time to time, subject to the terms of the Schedule of Requirements/Work Order.
- 4.3 Each properly executed Purchase Order forms an inseparable part of this Agreement as if it were fully incorporated into the body of this Agreement.
- 4.4 During the period of this Agreement, both Parties can make written suggestions for amendments to the Schedule of Requirements/Work Orders in accordance with procedures set out in clause 362 [*Amendment and Change Control*]. A Party will advise the other Party within 14 [fourteen] Business Days, or such other period as mutually agreed, whether the amendment is acceptable.
- 4.5 Insofar as any term, provision or condition in the Schedule of Requirements/Work Order conflicts with a like term, provision or condition in this Agreement and/or a Purchase Order, the term or provision or condition in this Master Agreement shall prevail, unless such term or provision or condition in this Master Agreement has been specifically revoked or amended by mutual written agreement between the Parties.
- 4.6 Time will be of the essence and the Supplier/Service Provider will perform its obligations under this Agreement in accordance with the timeframe(s) [if any] set out in the relevant schedule, save that the Supplier/Service Provider will not be liable under this clause if it is unable to meet such obligation within the time required as a direct result of any act or omission by Transnet and it has used its best endeavours to advise Transnet of such act or omission. In the event of such delay, any time deadlines detailed in the relevant schedule shall be extended by a period equal to the period of that delay.

5 AUTHORITY OF PARTIES

- 5.1 Nothing in this Agreement will constitute or be deemed to constitute a partnership between the Parties, or constitute or be deemed to constitute the Parties as agents or employees of one another for any purpose or in any form whatsoever.
- 5.2 Neither Party shall be entitled to, or have the power or authority to:
 - a) enter into an agreement in the name of the other; or
 - b) give any warranty, representation or undertaking on the other's behalf; or
 - c) create any liability against the other or bind the other's credit in any way or for any purpose whatsoever.

6 DURATION/TERM AND CANCELLATION

- 6.1 Notwithstanding the date of signature hereof, the Commencement Date if this Agreement is [REDACTED] and the duration shall be for a [REDACTED] [REDACTED] year period, expiring on [REDACTED], unless:
 - a) this Agreement is terminated by either Party in accordance with the provisions incorporated herein or in any schedules or annexures appended hereto, or otherwise in accordance with law or equity; or
 - b) this Agreement is extended at Transnet's option for a further period to be agreed by the Parties.
- 6.2 Notwithstanding clause 239 [*Breach and Termination*], either Party may cancel this Agreement without cause by giving 30 [thirty] calendar days prior written notice thereof to the other Party, provided that in such instance, this Agreement will nevertheless be applicable in respect of all Purchase Orders which have been placed prior to the date of such cancellation.

7 RISK MANAGEMENT

- 7.1 Where Transnet determines appropriate, within 2 weeks from the date of contract signature, the Parties are to meet to prepare and maintain a contract Risk Register. The Risk Register shall include a description of the risks and a description of the actions which are to be taken to avoid or reduce these risks which both Parties shall jointly determine.
- 7.2 Contract progress meetings shall be held monthly, or unless otherwise agreed between the Parties in writing. The purposes of these progress meetings shall be to capture the number of late deliverables against agreed milestones, actual costs against payment plans, performance issues or concerns, contract requirements not achieved, the status of previous corrective actions and risk management. Minutes of meetings shall be maintained and signed off between the Parties throughout the contract period

8 TRANSNET'S OBLIGATIONS

- 8.1 Transnet undertakes to promptly comply with any reasonable request by the Supplier/Service Provider for information, including information concerning Transnet's operations and activities, that relates to the Goods/Services as may be necessary for the Supplier/Service Provider to provide the Goods/Services, but for no other purpose. However, Transnet's compliance with any request for information is subject to any internal security rules and requirements and subject to the observance by the Supplier/Service Provider of its confidentiality obligations under this Agreement.
- 8.2 The Supplier/Service Provider shall give Transnet reasonable notice of any information it requires.
- 8.3 Transnet agrees to provide the Supplier/Service Provider or its Personnel such access to and use of its facilities as is necessary to allow the Supplier/Service Provider to perform its obligations under this Agreement.

9 GENERAL OBLIGATIONS OF THE SUPPLIER/SERVICE PROVIDER

- 9.1 The Supplier/Service Provider shall:
- a) respond promptly to all complaints and enquiries from Transnet;
 - b) inform Transnet immediately of any dispute or complaint arising in relation to the storage or delivery of the Goods;
 - c) conduct its business in a professional manner which will reflect positively upon the Supplier/Service Provider and the Supplier's/Service Provider's products/services;
 - d) keep full records clearly indicating all transactions concluded by the Supplier/Service Provider relating to the delivery of the Goods/Services and keep such records for at least 5 [five] years from the date of each such transaction;
 - e) obtain, and at all times maintain in full force and effect, any and all licences, permits and the like required under applicable laws for the provision of the Goods/Services and ancillary Services and the conduct of the business and activities of the Supplier/Service Provider;
 - f) observe and ensure compliance with all requirements and obligations as set out in the labour and related legislation of South Africa, including the Occupational Health and Safety Act, 85 of 1993, as may be amended from time to time;
 - g) observe and ensure compliance with all requirements and objectives of the Transnet Supplier Integrity Pact as agreed to in response to the RFP. The general purpose of the Supplier Integrity Pact is to agree to avoid all forms of dishonesty, fraud and corruption by following a

Supply and delivery of OHTE wires as and when required for the Eastern Region for a period of 12 months

system that is fair, transparent and free from any undue influence prior to, during and subsequent to the currency of the procurement event leading to this Agreement and this Agreement itself;

- h) comply with all applicable environmental legislation and regulations, demonstrate sound environmental performance and have an environmental management policy which ensures that its products, including the Goods/Services or ancillary Services are procured, produced, packaged, delivered and are capable of being used and ultimately disposed of in a way that is environmentally appropriate; and
- i) ensure the validity of all renewable certifications, including but not limited to its B-BBEE Verification Certificate, throughout the entire term of this Agreement. Should the Supplier/Service Provider fail to present Transnet with such renewals as they become due, Transnet shall be entitled, in addition to any other rights and remedies that it may have in terms of the Agreement, to terminate this Agreement forthwith without any liability and without prejudice to any claims which Transnet may have for damages against the Supplier/Service Provider.

9.2 The Supplier/Service Provider acknowledges and agrees that it shall at all times:

- a) render the supply of the Goods/Services and ancillary Services (if applicable) and perform all its duties with honesty and integrity;
- b) communicate openly and honestly with Transnet regarding the supply and performance of the Goods/Services and demonstrate a commitment to effecting the supply and performing ancillary Services timeously, efficiently and at least to the required standards;
- c) endeavour to provide the highest possible standards of service and workmanship, with a reasonable degree of care and diligence;
- d) use its best endeavours and make every diligent effort to meet agreed deadlines;
- e) treat its own Staff, as well as all Transnet's Staff, with fairness and courtesy and respect for their human rights;
- f) practice and promote its own internal policies aimed at prohibiting and preventing unfair discrimination;
- g) treat all enquiries from Transnet in connection with the supply of the Goods/Services and/or ancillary Services with courtesy and respond to all enquiries promptly and efficiently. Where the Supplier/Service Provider is unable to comply with the provisions of this clause, the Supplier/Service Provider will advise Transnet of the delay and the reasons therefor and will keep Transnet informed of progress made regarding the enquiry;
- h) when requested by Transnet, provide clear and accurate information regarding the Supplier's/Service Provider's own policies and procedures, excluding Know-How and other Confidential Information, except where a non-disclosure undertaking has been entered into between the Parties;
- i) not allow a conflict of interest to develop between its own interests [or the interests of any of its other customers] and the interests of Transnet;

Supply and delivery of OHTE wires as and when required for the Eastern Region for a period of 12 months

- j) not accept or offer, nor allow, induce or promote the acceptance or offering of any gratuity, enticement, incentive or gift that could reasonably be regarded as bribery or an attempt to otherwise exert undue influence over the recipient;
 - k) not mislead Transnet or its officers, employees and stakeholders, whether by act or omission;
 - l) not otherwise act in an unethical manner or do anything which could reasonably be expected to damage or tarnish Transnet's reputation or business image;
 - m) immediately report to Transnet any unethical, fraudulent or otherwise unlawful conduct of which it becomes aware in connection with Transnet or the supply of Goods/Services or ancillary Services to Transnet;
 - n) ensure that at all times, during the currency of this Agreement, it complies with all obligations and commitments in terms of the provisions of the Income Tax Act, No 58 of 1962, the VAT Act or any other tax legislation relating to their liability for Income Tax, VAT, Pay as You Earn or any other tax. The Supplier/Service Provider shall further ensure Tax Clearance Compliance, for the duration of this Agreement;
 - o) not victimise, harass or discriminate against any employee of either Party to this Agreement or any applicant for employment with either Party to this Agreement due to their gender, race, disability, age, religious belief, sexual orientation or part-time status. This provision applies, but is not limited to employment, upgrading, work environment, demotion, transfer, recruitment, recruitment advertising, termination of employment, rates of pay or other forms of compensation and selection for training.
 - p) shall ensure that its employees, agents and Subcontractors will not breach any applicable discrimination legislation and any amendments and re-enactments thereof.
- 9.3 In compliance with the National Railway Safety Regulator Act, 16 of 2002, as may be amended from time to time, the Supplier shall ensure that the Goods/Services and ancillary Services, to be supplied to Transnet under the terms and conditions of this Agreement, comply fully with the Specifications as set forth in Schedule 1 hereto, and shall thereby adhere [as applicable] to railway safety requirements and/or regulations. Permission for the engagement of a Subcontractor by the Supplier, as applicable, shall be subject to a review of the capability of the proposed Subcontractor to comply with the specified railway safety requirements and/or regulations. The Supplier and/or its Subcontractor shall grant Transnet access, during the term of this Agreement, to review any safety-related activities, including the coordination of such activities across all parts of its organisation.

10 SUBCONTRACTING

- 10.1 The Supplier/Service Provider may only enter into a subcontracting arrangement or replace a subcontractor with the approval of Transnet.
- 10.2 If the Supplier/Service Provider subcontracts a portion of the contract to another person without declaring it to Transnet reserves the right to penalise the Supplier/Service Provider up to 10% of the value of the contract.
- 10.3 Where the Supplier/Service Provider seeks to replace a subcontractor Transnet shall be entitled to obtain representations or input from the initial subcontractor who was part of the tender process whose credentials were used in the Supplier/Service Provider's tender submission. Transnet shall consider input from all parties concerned, in order to take a decision on the proposed replacement of

Supply and delivery of OHTE wires as and when required for the Eastern Region for a period of 12 months

the subcontractor. The subcontracting arrangement or contract remains between the Supplier/Service Provider (main contractor) and the subcontractor.

- 10.4 Should Transnet approve the Supplier's/Service Provider's subcontracting arrangement, the Supplier/Service Provider and not the Sub-contractor will at all times be held liable for performance in terms of its contractual obligations.
- 10.5 The Supplier/Service Provider may not subcontract in such a manner that the the overall value of the contract is reduced to below the stipulated minimum threshold.
- 10.6 The Supplier/Service Provider may not subcontract more than 25% of the value of the contract to any other enterprise that does not have an equal or higher B-BBEE status level of contributor than the Supplier/Service Provider, unless the contract is subcontracted to an Exempted Micro Enterprise (EME) that has the capability and ability to execute the Subcontract.

11 PAYMENT TO SUB-CONTRACTORS

- 11.1 Transnet reserves the right, in its sole discretion, to make payment directly to the sub-contractor of the Supplier/Service Provider, subject to the following conditions:
 - a) Receipt of an undisputed invoice from the sub-contractor; and
 - b) Receipt of written confirmation from the Supplier/Service Provider that the amounts claimed by the sub-contractor are correct and that the services for which the sub-contractor has requested payment were rendered to the satisfaction of the Supplier/Service Provider, against the required standards.
- 11.2 Nothing contained in this clause must be interpreted as bestowing on any sub-contractor a right or legitimate expectation to be paid directly by Transnet. Furthermore, this clause does not bestow any right or legitimate expectation on the Supplier/Service provider to demand that Transnet pay its sub-contractor directly. The decision to pay any sub-contractor directly, remains that of Transnet alone.
- 11.3 The Supplier/Service Provider remains liable for its contractual obligations under the Agreement, including all services rendered by the sub-contractor.
- 11.4 This clause does not establish any contractual relationship between Transnet and any sub-contractor of the Supplier/Service Provider, whatsoever.

12 B-BBEE AND SOCIO-ECONOMIC OBLIGATIONS

12.1 B-BBEE Scorecard

- a) Transnet fully endorses and supports the Broad-Based Black Economic Empowerment Programme and is strongly of the opinion that all South African business enterprises have an equal obligation to redress the imbalances of the past.
- b) In response to this requirement, the Supplier/Service Provider shall submit to Transnet's Contract Manager or such other designated person details of its B-BBEE status in terms of the latest Codes of Good Practice issued in terms of the B-BBEE Act and proof thereof at the beginning of March each year during the currency of this Agreement.
- c) The Supplier/Service Provider undertakes to notify and provide full details to Transnet in the event there is:

Supply and delivery of OHTE wires as and when required for the Eastern Region for a period of 12 months

- (i) a change in the Supplier's/Service Provider's B-BBEE status which is less than what it was at the time of its appointment including the impact thereof; and
 - (ii) a corporate or internal restructure or change in control of the Supplier/Service Provider which has or likely to impact negatively on the Supplier's/ Service Provider's B-BBEE status.
- d) Notwithstanding any other reporting requirement in terms hereof, the Supplier Service Provider undertakes to provide any B-BBEE data (underlying data relating to the Supplier /Service Provider which has been relied upon or utilised by a verification agency or auditor for the purposes of issuing a verification certificate in respect of the Supplier/Service Provider B-BBEE status) which Transnet may request on written notice within 30 (thirty) calendar days of such request. A failure to provide such data shall constitute a Supplier/ Service Provider Default and may be dealt with in accordance with the provisions of clause 239.
- e) In the event there is a change in the Supplier's/ Service Provider's B-BBEE status, then the provisions of clause 239 shall apply.

12.2 Green Economy/Carbon Footprint

- a) The Supplier/Service Provider has in its bid provided Transnet with an understanding of the Supplier's/Service Provider's position with regard to issues such as waste disposal, recycling and energy conservation.

13 PENALTIES

13.1 Penalties for Non-compliance to Service Level Agreement

Where the Supplier/Service Provider fails to deliver the Goods/Services within the agreed and accepted milestone timelines and provided that the cause of the delay was not due to a fault of Transnet, penalties shall be imposed at

- a) The Parties have agreed on the following milestone targets ("the Local Content Plan"):
 -

14 INVOICES AND PAYMENT

- 14.1 Transnet shall pay the Supplier/Service Provider the amounts stipulated in each Purchase Order/Work Order, subject to the terms and conditions of this Agreement.
- 14.2 Transnet shall pay such amounts to the Supplier/Service Provider upon receipt of a valid and undisputed Tax Invoice together with the supporting documentation, as specified in the Schedule of Requirements appended hereto, once the valid and undisputed Tax Invoices or such portions of the Tax Invoices which are valid and undisputed become due and payable to the Supplier/Service Provider for the delivery of the Goods/Services ordered, in terms of clause 14.5 below.
- 14.3 Transnet may, pending an investigation, withhold any payments to the Supplier/Service Provider, in the case where irregular expenditure has been identified in the particular contract and that there is reasonable suspicion that the Supplier/Service Provider is involved or was aware that the contract transgressed any legislation.
- 14.4 All Prices set out in this Agreement and the Schedule of Requirements hereto are to be indicated inclusive and exclusive of VAT, which will be payable at the applicable rate in ZAR.

Supply and delivery of OHTE wires as and when required for the Eastern Region for a period of 12 months

- 14.5 Unless otherwise provided for in the Schedule of Requirements appended to this Agreement, Tax Invoices shall be submitted together with a month-end statement. Payment against such month-end statement shall be made by Transnet within 30 [thirty] calendar days after date of receipt by Transnet of the Supplier's/Service Provider's statement together with the relevant valid and undisputed Tax Invoice(s) and supporting documentation.
- 14.6 Where the payment of any Tax Invoice, or any part of a Tax Invoice which is not in dispute, is not made in accordance with this clause, the Supplier/Service Provider shall be entitled to charge interest on the outstanding amount, at The Standard Bank of South Africa's prime rate of interest in force, for the period from the due date of payment until the outstanding amount is paid.
- 14.7 The Supplier/Service Provider shall remain the owner of all plant, material, machinery, equipment and the like [collectively, **the Supplier's Goods**] provided to Transnet until Transnet has paid in full for the Supplier's Goods, it being specifically agreed that Transnet shall acquire no rights [including liens] of whatsoever nature in such Supplier's Goods until date of final payment by Transnet. Subject to the foregoing, all risk and benefit to the Supplier's Goods shall pass from the Supplier to Transnet on delivery of the Supplier's Goods by the Supplier to Transnet.

15 PRICE ADJUSTMENTS

- 15.1 Prices for Goods/Services supplied in terms of this Agreement shall be subject to review as indicated in the Schedule of Requirements/Works Order annexed hereto.
- 15.2 No less than 2 [two] months prior to any proposed Price adjustment, the Parties shall commence negotiations for Prices for the next period or as otherwise indicated in Schedule 1 hereto. The Parties shall have regard for market-related pricing of equivalent goods, continuous improvement initiatives, costs [including labour, raw materials and transport/delivery], order size and frequency and changes to the specification of the Goods/Services.
- 15.3 Pursuant to clause 15.2 above, the Supplier/Service Provider shall keep full and accurate records of all costs associated with the supply of the Goods/Services to Transnet, in a form to be approved in writing by Transnet. The Supplier/Service Provider shall produce such records to Transnet for inspection at all reasonable times on request and such records may, at Transnet's option, be audited by Transnet or its designated representatives.
- 15.4 Should Transnet and the Supplier/Service Provider fail to reach an agreement on Price for the successive period, either Party shall be entitled to submit this matter to dispute resolution in accordance with clause 39 of the Master Agreement [Dispute Resolution].
- 15.5 If during the period of this Agreement Transnet can purchase similar Goods/Services of a like quality from another supplier at a total delivered cost to a Transnet facility that is lower than the total delivered cost of the Goods/Services purchased hereunder from the Supplier/Service Provider, Transnet may notify the Supplier/Service Provider of such total delivered cost and the Supplier/Service Provider shall have an opportunity to adjust the Price of the Goods/Services purchased hereunder, on such a basis as to result in the same total delivered cost to Transnet, within 30 [thirty] calendar days of such notice. If the Supplier/Service Provider fails to do so or cannot legally do so, Transnet may (i) purchase the Goods/Services from such other supplier in which case the obligations, including, but not limited to, any purchase and sale requirements and/or commitments, if any, of Transnet and the Supplier/Service Provider hereunder shall be

Supply and delivery of OHTE wires as and when required for the Eastern Region for a period of 12 months

reduced accordingly; (ii) terminate this Agreement without any penalty, liability or further obligation; or (iii) continue purchases under this Agreement.

15.6 If during the period of this Agreement the Supplier/Service Provider sells any materials which are the same as, equivalent to, or substantially similar to the Goods/Services herein, at a total delivered cost to a third party lower than the total delivered cost to a Transnet facility, then the Supplier/Service Provider has an opportunity to adjust its Price for the Goods/Services purchased hereunder within 30 [thirty] calendar days so that the Price is the same or lower than the total delivered cost of such third party. If the Supplier/Service Provider fails to do so or cannot legally do so, Transnet may (i) purchase the Goods/Services from any other such supplier, in which case the obligations, including, but not limited to, any purchase and sale requirements and/or commitments, if any, of Transnet and the Supplier/Service Provider hereunder shall be reduced accordingly; or (ii) terminate this Agreement without any penalty, liability or further obligation. Within 30 [thirty] calendar days of the Commencement Date of this Agreement or at any time Transnet so requests, the Supplier/Service Provider shall certify in writing to Transnet that it is in compliance with this clause and shall provide all information that Transnet reasonably requests in order to verify such compliance.

16 WARRANTIES APPLICABLE TO GOODS

The Supplier warrants that:

- 16.1 pursuant to clause 9.3 [General Obligations of the Supplier], the Goods will be manufactured in accordance with the specifications appended hereto at Schedule 1, or the manufacturer's specifications, as agreed in writing by both Parties;
- 16.2 the execution and performance of this Agreement by the Supplier does not infringe any rights of a third party or breach any obligation of the Supplier to any third party; and
- 16.3 it has taken all reasonable precautions to ensure that, in the event of a disaster, the impact of such disaster on the ability of the Supplier to comply with its obligations under this Agreement will be reduced to the greatest extent possible, and that the Supplier shall ensure that it has appropriate, tested and documented recovery arrangements in place.

17 THIRD PARTY INDEMNITY

The Supplier/Service Provider hereby indemnifies and shall hold Transnet harmless against any direct damages suffered by or claims arising against Transnet in respect of clause 16.2 above.

18 INSPECTION APPLICABLE TO GOODS

- 18.1 Transnet reserves the right to arrange for the inspection of all Goods forming the subject of any Purchase Order, at any stage before final acceptance and by any means it may think fit, and when such inspection is to be carried out, the relevant Purchase Order(s) shall be endorsed accordingly.
- 18.2 When inspection at the Supplier's works or warehouse is specified, Transnet's authorised inspector shall have free access to the premises of the Supplier at all times during working hours on a Business Day; shall have liberty to inspect work which is the subject of the Purchase Order at any stage of manufacture, and may reject any Goods which are found to be incomplete, defective or in any way not in conformity with the terms and specifications of this Agreement; and the Supplier shall afford all reasonable facilities for such access and inspection.

Supply and delivery of OHTE wires as and when required for the Eastern Region for a period of 12 months

- 18.3 The Supplier shall provide inspection gauges, measuring and test equipment to ensure that the requirements of this Agreement are satisfied. All gauges, templates, tools and other equipment required to check the accuracy of the work shall be calibrated at regular and reasonable intervals by a laboratory which has been approved in writing by Transnet. This certificate shall not be more than 12 [twelve] months old.
- 18.4 The Supplier shall prepare and supply, without charge to Transnet, all test pieces, samples and specimens; shall provide all labour and apparatus for carrying out tests and analyses in accordance with the terms of this Agreement or Purchase Order, and render all reasonable assistance in making such tests and analyses.
- 18.5 All special rules governing gauging, testing, analysis and other inspection procedures shall be adhered to strictly in accordance with the terms of this Agreement or Purchase Order and the conditions of any specifications and drawings quoted therein.
- 18.6 Inspection will be arranged by the Staff of Transnet, as indicated in the Purchase Order(s).
- 18.7 When Goods are ready for inspection, the Supplier shall apply promptly to the appropriate authority for instructions regarding such inspection. All applications for inspection shall quote Transnet's Agreement or Purchase Order number. 7 [seven] Business Days' notice of readiness from the Supplier shall be given to the authorised inspector appointed by Transnet to carry out such inspection.
- 18.8 Transnet shall have the right to recover from the Supplier the cost of inspection of any Goods that have been rejected by its authorised inspector in terms of this clause 184.

19 DEFECTIVE GOODS

- 19.1 Notwithstanding any certificate and/or receipt that may have been issued by or on behalf of Transnet either in South Africa or overseas, Goods will be accepted at the place of delivery or at the port of shipment, as specified in this Agreement, only as regards outward condition of packages and Transnet retains the right to reject the Goods supplied, on or after arrival at the place to which they are consigned, or after they have been placed in use in South Africa, should they be found defective.
- 19.2 If Goods are rejected owing to latent defects becoming apparent during machining operations or other preparation necessary on the part of Transnet before they can be put into use, the Supplier shall bear all expenses incurred by Transnet in carrying out such necessary operations.
- 19.3 If such Goods are rejected, the Supplier will pay the following costs:
 - a) for Goods purchased in South Africa on an ex works basis, the cost of transport from the Supplier's works in South Africa to the named destination where the Goods have been rejected by Transnet, plus handling charges and storage, if leviable; or
 - b) for Goods manufactured overseas, the Supplier shall pay all replacement costs including the overseas inland transport cost, freight and insurance charges incurred plus railage or other inland transport costs from the South African port to the place where the Goods have been rejected by Transnet, including handling charges, storage, landing charges, customs duty and surcharges, if leviable.
- 19.4 If Transnet requires rejected Goods to be replaced, the Supplier shall, when called upon to do so, arrange prompt replacement of the Goods within the prescribed manufacturing lead times for such Goods, as indicated in Schedule 1.

Supply and delivery of OHTE wires as and when required for the Eastern Region for a period of 12 months

- 19.5 If Goods are found to be defective but the defects are, in the opinion of Transnet, not of so serious a nature as to warrant total rejection of the Goods, the Supplier shall, when called upon to do so, remedy or make good such defects at its own cost, or Transnet may remedy or make good such defects at the request of the Supplier and recover from the Supplier all costs or expenses reasonably incurred by it in doing so.
- 19.6 Should the Supplier fail, when called upon to remedy or make good such defects within a reasonable time or to request Transnet to do so, Transnet may proceed to remedy or make good such defects and thereafter recover from the Supplier all such costs and expenses as aforementioned.
- 19.7 Any amount recoverable from the Supplier in terms of this clause may, without prejudice to any other legal remedies available to Transnet, be deducted in whole or in part from any monies in the hands of Transnet which are due for payment to the Supplier.

20 TOTAL OR PARTIAL FAILURE TO PERFORM

- 20.1 In the case of Goods to be specially manufactured for it, if Transnet at any time ascertains that:
- a) no manufacturing of the Goods specified in a Purchase Order has commenced and there is little or no prospect, in Transnet's opinion, that manufacturing will commence within a reasonable time; or
 - b) delivery of any of the Goods is being or is likely to be delayed beyond the promised delivery date(s), and there is little or no prospect of the Purchase Order(s) being carried out within reasonable adherence to the promised delivery rate(s) or time(s),
- then Transnet may, irrespective of the cause of the delay, by notice to the Supplier, cancel as from a future date specified in such notice the whole or any part of this Agreement or Purchase Order in respect of which the Goods to be supplied have not been completed by that date, without incurring any liability by reason of such cancellation except as provided in this clause.
- 20.2 The Supplier/Service Provider shall thereupon, as soon as possible after such date, deliver to Transnet the Goods/Services [if any] already completed, and payment for the part performance shall be made on a pro rata basis, provided the uncompleted part is not an integral or essential part of the completed Goods/Services. Where an integral or essential part of the work has not been completed, the amount to be paid to the Supplier/Service Provider will be calculated on the basis of Transnet's enrichment. The Supplier/Service Provider shall, wherever practicable, supply Transnet with the necessary drawings and/or specifications to enable it to complete the work.
- 20.3 Whenever, in any case not covered by clause 20.1 above, the Supplier fails or neglects to execute the work or to deliver any portion of the Goods/Services as required by the terms of this Agreement or Purchase Order, or if any Goods/Services are rejected on any of the grounds mentioned in clause 195 [Defective Goods], Transnet may cancel this Agreement or Purchase Order in so far as it relates to the unexecuted work or the undelivered or rejected portion of the Goods/Services, and in such event, the supply of the remaining portion shall remain subject in all respects to these conditions.

21 NON CONFORMANCE OF GOODS/SERVICES PROCURED

- 21.1 *In the case of Goods/services manufactured for and procured by Transnet from the Supplier/Service Provider in terms of this Agreement, being found not to conform to the Transnet standards, specifications and requirements, Transnet at any time may be entitled to raise a Non Conformance*

Supply and delivery of OHTE wires as and when required for the Eastern Region for a period of 12 months

Report (NCR) against a Supplier/Service Provider whose Goods/ Services do not conform to Transnet standards, specifications and requirements directing the Supplier/Service Provider to investigate and remedy the non-conformance within the stipulated time frame as may be determined by Transnet at its discretion.

21.2 *Failure by the Supplier/Service Provider to fully comply with NCR within the period stated in sub-clause 26.1 above, shall entitle Transnet to further conditions to which the Supplier/ Service Provider must discharge in order to close the NCR or to terminate the order without giving the Supplier/Service Provider written notice of termination in terms of this Agreement.*

22 RIGHTS ON CANCELLATION

22.1 If this Agreement or Purchase Order is cancelled in whole or in part in terms of clause 206 [*Total or Partial Failure to Perform*], Transnet may execute or complete this Agreement with any other entity and do so on such terms as it may deem proper, or may procure other comparable Goods/Services in substitution for those neglected to be manufactured or supplied or rejected as aforesaid, and may recover from the Supplier the difference between the cost of such Goods/Services and the Price [if the latter was lower] as well as any costs and expenses [including any additional transport costs] which Transnet may have had to incur in consequence of the Supplier's/Service Provider's default.

22.2 Any amount which may be recoverable from the Supplier/Service Provider in terms of clause 22.1 above, without prejudice to any other legal remedies available to Transnet, may be deducted in whole or in part from any monies in the hands of Transnet and due for payment to the Supplier/Service Provider.

23 BREACH AND TERMINATION

23.1 Termination in accordance with clause 6 [Term and Cancellation] shall not prejudice or affect any right of action or remedy which shall have accrued or shall thereafter accrue to either Party and all provisions which are to survive this Agreement or impliedly do so shall remain in force and in effect.

23.2 On termination of this Agreement or a Work Order, the Service Provider will immediately deliver up, and procure that its Personnel will immediately deliver up to Transnet, all Deliverables and property belonging to Transnet [or, in the event of termination of a Work Order, such as is relevant to that Work Order] which may be in the possession of, or under the control of the Service Provider, and certify to Transnet in writing that this has been done.

23.3 To the extent that any of the Deliverables and property referred to in clause 23.2 above are in electronic form and contained on non-detachable storage devices, the Service Provider will provide Transnet with unencrypted copies of the same on magnetic media and will irretrievably destroy and delete copies so held.

23.4 In the event that this Agreement is terminated by the Service Provider under clause **Error! Reference source not found.** [Term and Cancellation], or in the event that a Work Order is terminated by Transnet under clause **Error! Reference source not found.**⁹ [Breach and Consequences of Termination], Transnet will pay to the Service Provider all outstanding Fees [apportioned on a pro rata basis] relating to the work undertaken by the Service Provider up until the date of such termination. Transnet will also pay the costs of any goods and materials ordered by the Service Provider in relation to the such work for which the Service Provider has paid or is legally obliged to pay, in which case, on delivery of such goods or materials, the Service Provider will promptly deliver such goods and materials to Transnet or as it may direct.

Supply and delivery of OHTE wires as and when required for the Eastern Region for a period of 12 months

- 23.5 If either Party [**the Defaulting Party**] commits a material breach of this Agreement and fails to remedy such breach within 30 [thirty] calendar days of written notice thereof, the other Party [hereinafter **the Aggrieved Party**], shall be entitled, in addition to any other rights and remedies that it may have in terms of this Agreement, to terminate this Agreement forthwith without any liability and without prejudice to any claims which the Aggrieved Party may have for damages against the Defaulting Party.
- 23.6 Either Party may terminate this Agreement forthwith by notice in writing to the other Party when the other Party is unable to pay its debts as they fall due or commits any act or omission which would be an act of insolvency in terms of the Insolvency Act, 24 of 1936 [as amended from time to time], or if any action, application or proceeding is made with regard to it for:
- a) a voluntary arrangement or composition or reconstruction of its debts;
 - b) its winding-up or dissolution;
 - c) the appointment of a liquidator, trustee, receiver, administrative receiver or similar officer;
 - d) any similar action, application or proceeding in any jurisdiction to which it is subject.
- 23.7 Transnet may terminate this Agreement at any time within 2 [two] months of becoming aware of a change of control of the Supplier/Service Provider by notice in writing to the Supplier/Service Provider. For the purposes of this clause, **control** means the right to direct the affairs of a company whether by ownership of shares, membership of the board of directors, agreement or otherwise.
- 23.8 Notwithstanding this clause 239, Transnet may cancel this Agreement without cause by giving 30 [thirty] calendar days prior written notice thereof to the Supplier/Service Provider, or
- 23.9 The provisions of clauses 2 [Definitions], 162 [Warranties], 228 [Rights on Cancellation], 263 [Confidentiality], 295 [Limitation of Liability], 36 [Intellectual Property Rights], 339 [Dispute Resolution] and 37.1 [Governing Law] shall survive termination or expiry of this Agreement.

24 CESSIONS AND ASSIGNMENTS AS PER NT INSTRUCTION NOTE 08 OF 2022/2023

- 24.1 The Supplier/Service Provider is not allowed to cede its rights for payment in terms of this Agreement without prior written approval from Transnet. Cession shall only be applicable as follows:
- a) Cession must only be applicable to the transfer of right to payment for goods/services delivered/rendered by a Supplier/Service Provider to an FSP or State Institutions;
 - b) The written request for cession must be by the Supplier/Service Provider and not a third party; and
 - c) The written request by the Supplier/Service Provider must be accompanied by the cession agreement.
- 24.2 The Supplier/Service Provider is prohibited from transferring its rights and obligations to perform under this contract. Assignments are against the principles of section 217 of the Constitution mainly, fairness, transparency and competitiveness.

25 FORCE MAJEURE

- 25.1 Neither Party shall have any claim against the other Party arising from any failure or delay in the performance of any obligation of either Party under this Agreement caused by an act of force majeure such as acts of God, fire, flood, war, lockout, government action, laws or regulations, terrorism or civil disturbance, defaults or other circumstances or factors beyond the reasonable

Supply and delivery of OHTE wires as and when required for the Eastern Region for a period of 12 months

control of either Party, and to the extent that the performance of obligations of either Party hereunder is delayed by virtue of the foregoing, any period stipulated for any such performance shall be reasonably extended. Transnet may however rely on strikes, industrial dispute and riots as a ground of force majeure.

25.2 Each Party will take all reasonable steps by whatever lawful means that are available to resume full performance as soon as practicable and will seek agreement to modification of the relevant provisions of this Agreement in order to accommodate the new circumstances caused by the act of *force majeure*. If a Party fails to agree with such modifications proposed by the other Party within 90 [ninety] calendar days of the act of *force majeure* first occurring, either Party may thereafter terminate this Agreement with immediate notice.

26 PROTECTION OF PERSONAL INFORMATION

a) The following terms shall bear the same meaning as contemplated in Section 1 of the Protection of Personal Information Act 4 of 2013 ("POPIA"):

consent; person; personal information; processing; record; Regulator as well as any terms derived from these terms of the POPIA

b) Transnet will process all information by the Respondent in terms of the requirements contemplated in Section 4(1) of the POPIA:

Accountability; Processing limitation; Purpose specification; Further processing limitation; Information quality; Openness; Security safeguards and Data subject participation.

c) Transnet agrees that in submitting any information or documentation requested in the RFP and in this Agreement, the Supplier/Service Provider consents to the processing of their personal information for the purpose of, but not limited to, risk assessment, contract award, contract management, auditing, legal opinions/litigation, investigations (if applicable), document storage for the legislatively required period, destruction, de-identification and publishing of personal information by Transnet and/or its authorised appointed third parties.

d) The Parties agree that they may obtain and have access to personal information for the fulfilment of the rights and obligations contained herein. In performing the obligations as set out in this Agreement, the Parties shall at all times ensure that:

- i. they process personal information only for the express purpose for which it was obtained;
- ii. once processed for the purposes for which it was obtained, all personal information will be destroyed to an extent that it cannot be reconstructed to its original form, subject to any legal retention requirements;
- iii. Personal information is provided only to authorised personnel who strictly require the personal information to carry out the Parties' respective obligations under this Agreement;
- iv. they do not disclose personal information of the other Party, other than in terms of this Agreement;
- v. they have all reasonable technical and organisational measures in place to protect all personal information from unauthorised access and/or use;

Supply and delivery of OHTE wires as and when required for the Eastern Region for a period of 12 months

- vi. they have appropriate technical and organisational measures in place to safeguard the security, integrity and authenticity of all information in their possession or under their control in terms of this Agreement;
 - vii. they identify all reasonably foreseeable internal and external risks to personal information in their possession or under their control; establish and maintain appropriate safeguards against the risks identified; regularly verify that the safeguards are effectively implemented; and ensure that the safeguards are continually updated in response to new risks or deficiencies in previously implemented safeguards;
 - viii. such personal information is protected against unauthorised or unlawful processing, accidental loss, destruction or damage, alteration, disclosure or access.
- 26.1 The Parties agree that if personal information will be processed for additional purposes beyond the original purpose for which it was obtained, explicit consent must be obtained beforehand from those persons whose information will be subject to such processing.
- 26.2 Should it be necessary for either Party to disclose or otherwise make available the personal information to any third party (including sub-contractors and employees) that is not already consented to, it may do so only with the prior written consent of the other Party. The Party requiring such consent shall require of all such third parties, appropriate written undertakings to be provided, containing similar terms to that set forth in this clause, and dealing with that third party's obligations in respect of its processing of the personal information. Following approval by the other Party, the Party requiring consent agrees that the provisions of this clause shall *mutatis mutandis* apply to all authorised third parties who process personal information.
- 26.3 The Parties shall ensure that any persons authorized to process information on their behalf (including employees and third parties) will safeguard the security, integrity and authenticity of all information. Where necessary to meet this requirement, the Parties shall keep all personal information and any analyses, profiles, or documents derived therefrom logically separated from all other information and documentation held by it.
- 26.4 The Parties shall carry out regular assessments to identify all reasonably foreseeable internal and external risks to the personal information in its possession or under its control. The Parties shall implement and maintain appropriate safeguards against the risks which it identifies and shall also regularly verify that the safeguards which it has in place have been effectively implemented.
- 26.5 The Parties agree that they will promptly return, destroy or de-identify any personal information in their possession or control which belongs to the other Party once it no longer serves the purpose for which it was collected in relation to this Agreement, subject to any legal retention requirements. This may be at the request of the other Party and includes circumstances where a person has requested the Parties to delete all instances of their personal information. The information will be destroyed or de-identified in such a manner that it cannot be reconstructed to its original form, linking it to any particular individual or organisation.
- 26.6 Personal Information security breach:
- a) Each Party shall notify the other party in writing as soon as possible after it becomes aware of or suspects any loss, unauthorised access or unlawful use of any personal information and shall, at its own cost, take all necessary remedial steps to mitigate the extent of the loss or compromise of personal information and to restore the integrity of the affected personal

Supply and delivery of OHTE wires as and when required for the Eastern Region for a period of 12 months

information as quickly as is possible. The Parties shall also be required to provide each other with details of the persons affected by the compromise and the nature and extent of the compromise, including details of the identity of the unauthorised person who may have accessed or acquired the personal information.

- b) The Parties shall provide on-going updates on the progress in resolving the compromise at reasonable intervals until such time as the compromise is resolved.
- c) Where required, the Parties must notify the South African Police Service; and/or the State Security Agency and the Information Regulator and the affected persons of the security breach. Any such notification shall always include sufficient information to allow the persons to take protective measures against the potential consequences of the compromise.
- d) The Parties undertake to co-operate in any investigations relating to security which is carried out by or on behalf of the other including providing any information or material in its possession or control and implementing new security measures.

27 CONFIDENTIALITY

27.1 The Parties hereby undertake the following with regard to Confidential Information:

- a) not to divulge or disclose to any person whomsoever in any form or manner whatsoever, either directly or indirectly, any Confidential Information of the other without the prior written consent of such other Party, other than when called upon to do so in accordance with a statute, or by a court having jurisdiction, or by any other duly authorised and empowered authority or official, in which event the Party concerned shall do what is reasonably possible to inform the other of such a demand and each shall assist the other in seeking appropriate relief or the instituting of a defensive action to protect the Confidential Information concerned;
- b) not to use, exploit, permit the use of, directly or indirectly, or in any other manner whatsoever apply the Confidential Information disclosed to it as a result of this Agreement, for any purpose whatsoever other than for the purpose for which it is disclosed or otherwise than in strict compliance with the provisions in this Agreement;
- c) not to make any notes, sketches, drawings, photographs or copies of any kind of any part of the disclosed Confidential Information without the prior written consent of such other Party, except when reasonably necessary for the purpose of this Agreement, in which case such copies shall be regarded as Confidential Information;
- d) not to de-compile, disassemble or reverse engineer any composition, compilation, concept application, item, component de-compilation, including software or hardware disclosed and shall not analyse any sample provided by Transnet, or otherwise determine the composition or structure or cause to permit these tasks to be carried out except in the performance of its obligations pursuant to this Agreement;
- e) not to exercise less care to safeguard Transnet Confidential Information than the Party exercises in safeguarding its own competitive, sensitive or Confidential Information;
- f) Confidential Information disclosed by either Party to the other or by either Party to any other party used by such party in the performance of this Agreement, shall be dealt with as "restricted" or shall be dealt with according to any other appropriate level of confidentiality

Supply and delivery of OHTE wires as and when required for the Eastern Region for a period of 12 months

relevant to the nature of the information concerned, agreed between the Parties concerned and stipulated in writing for such information in such cases;

- g) the Parties shall not make or permit to be made by any other person subject to their control, any public statements or issue press releases or disclose Confidential Information with regard to any matter related to this Agreement, unless written authorisation to do so has first been obtained from the Party first disclosing such information;
- h) each Party shall be entitled to disclose such aspects of Confidential Information as may be relevant to one or more technically qualified employees or consultants of the Party who are required in the course of their duties to receive the Confidential Information for the Permitted Purpose provided that the employee or consultant concerned has a legitimate interest therein, and then only to the extent necessary for the Permitted Purpose, and is informed by the Party of the confidential nature of the Confidential Information and the obligations of the confidentiality to which such disclosure is subject and the Party shall ensure such employees or consultants honour such obligations;
- i) each Party shall notify the other Party of the name of each person or entity to whom any Confidential Information has been disclosed as soon as practicable after such disclosure;
- j) each Party shall ensure that any person or entity to which it discloses Confidential Information shall observe and perform all of the covenants the Party has accepted in this Agreement as if such person or entity has signed this Agreement. The Party disclosing the Confidential Information shall be responsible for any breach of the provisions of this Agreement by such person or entity; and
- k) each Party may by written notice to the other Party specify which of the Party's employees, officers or agents are required to sign a non-disclosure undertaking.

27.2 The duties and obligations with regard to Confidential Information in this clause 273 shall not apply where:

- a) a Party can demonstrate that such information is already in the public domain or becomes available to the public through no breach of this Agreement by that Party, or its Staff; or
- b) was rightfully in a Party's possession prior to receipt from the other Party, as proven by the first-mentioned Party's written records, without an infringement of an obligation or duty of confidentiality; or
- c) can be proved to have been rightfully received by a Party from a third party without a breach of a duty or obligation of confidentiality; or
- d) is independently developed by a Party as proven by its written records.

27.3 This clause 273 shall survive termination for any reason of this Agreement and shall remain in force and effect from the Commencement Date of this Agreement and 5 [five] years after the termination of this Agreement. Upon termination of this Agreement, all documentation furnished to the Supplier/Service Provider by Transnet pursuant to this Agreement shall be returned to Transnet including, without limitation, all corporate identity equipment including dyes, blocks, labels, advertising matter, printing matter and the like.

28 INSURANCES

28.1 Without limiting the liability of the Supplier/Service Provider under this Agreement, the Supplier/Service Provider shall take out insurance in respect of all risks for which it is prudent for

Supply and delivery of OHTE wires as and when required for the Eastern Region for a period of 12 months

the Supplier/Service Provider to insure against, including any liability it may have as a result of its activities under this Agreement for theft, destruction, death or injury to any person and damage to property. The level of insurance will be kept under review by Transnet, on an annual basis, to ensure its adequacy, provided that any variation to the level of such insurance shall be entirely at the discretion of the Supplier/Service Provider.

- 28.2 The Supplier/Service Provider shall arrange insurance with reputable insurers and will produce to Transnet evidence of the existence of the policies on an annual basis within 30 [thirty] calendar days after date of policy renewals.
- 28.3 Subject to clause 28.4 below, if the Supplier/Service Provider fails to effect adequate insurance under this clause 28.4, it shall notify Transnet in writing as soon as it becomes aware of the reduction or inadequate cover and Transnet may arrange or purchase such insurance on behalf of the Supplier/Service Provider. The Supplier/Service Provider shall promptly reimburse Transnet for any premiums paid provided such insurance protects the Supplier/Service Provider's liability. Transnet assumes no responsibility for such insurance being adequate to protect all of the Supplier/Service Provider's liability.
- 28.4 In the event that the Supplier/Service Provider receives written notice from its insurers advising of the termination of its insurance cover referred to in clause 28.1 above or if the insurance ceases to be available upon commercially reasonable terms, the Supplier/Service Provider shall immediately notify Transnet in writing of such termination and/or unavailability, whereafter either the Supplier/Service Provider or Transnet may terminate this Agreement on giving the other Party not less than 30 [thirty] calendar days prior written notice to that effect.

29 LIMITATION OF LIABILITY

- 29.1 The Supplier/Service Provider's liability under this clause 29.1 shall be in addition to any warranty or condition of any kind, express or implied by law or otherwise, relating to the Goods/Services or ancillary Services, including the quality of the Goods/Services or ancillary Services or any materials delivered pursuant to this Agreement.
- 29.2 Neither Party excludes or limits liability to the other Party for:
 - a) death or personal injury caused by its negligence, [including its employees', agents' or Subcontractors' negligence]; or
 - b) fraud or theft.
- 29.3 The Supplier/Service Provider shall indemnify and keep Transnet indemnified from and against liability for damage to any Transnet property [whether tangible or intangible] or any other loss, costs or damage suffered by Transnet to the extent that it results from any act of or omission by the Supplier/Service Provider or its Personnel in connection with this Agreement. The Supplier/Service Provider's liability arising out of this clause 29.3 shall be limited to direct damages.
- 29.4 Subject always to clauses 29.1 and 29.2 above, the liability of either the Supplier/Service Provider or Transnet under or in connection with this Agreement, whether for negligence, misrepresentation, breach of contract or otherwise, for direct loss or damage arising out of each Default or series of related Defaults shall not exceed 100% [one hundred per cent] of the Fees paid under the schedule or Work Order to which the Default(s) relates.
- 29.5 Subject to clauses 29.1 to 29.4 above, in no event shall either Party be liable to the other for indirect or consequential loss or damage or including indirect or consequential loss of profits,

Supply and delivery of OHTE wires as and when required for the Eastern Region for a period of 12 months

business, revenue, goodwill or anticipated savings of an indirect nature or loss or damage incurred by the other Party as a result of third party claims.

29.6 If for any reason the exclusion of liability in clause 29.5 above is void or unenforceable, either Party's total liability for all loss or damage under this Agreement shall be as provided in clause 29.3 above.

29.7 Nothing in this clause 295 shall be taken as limiting the liability of the Parties in respect of clauses 263 [*Confidentiality*] and 306 [*Intellectual Property Rights*].

30 INTELLECTUAL PROPERTY RIGHTS

30.1 Title to Confidential Information

- a) Transnet will retain all right, title and interest in and to its Confidential Information and Background Intellectual Property and the Supplier/Service Provider acknowledges that it has no claim of any nature in and to the Confidential Information and Background Intellectual Property that is proprietary to Transnet. For the avoidance of doubt all the Supplier/Service Provider's Background Intellectual Property shall remain vested in the Supplier/Service Provider.
- b) Transnet shall grant to the Supplier/Service Provider an irrevocable, royalty free, non-exclusive licence to use Transnet's Background Intellectual Property only for the Permitted Purpose. This licence shall not permit the Supplier/Service Provider to sub-license to other parties.
- c) The Supplier/Service Provider shall grant to Transnet an irrevocable, royalty free, non-exclusive licence to use the Supplier/Service Provider's Background Intellectual Property for the Permitted Purpose. This licence shall not permit Transnet to sub-license to other parties.
- d) The Supplier/Service Provider shall grant Transnet access to the Supplier/Service Provider's Background Intellectual Property on terms which shall be *bona fide* negotiated between the Parties for the purpose of commercially exploiting the Foreground Intellectual Property, to the extent that such access is required.
- e) The above shall not pertain to any software licenses procured by the Supplier/Service Provider from third parties and used in the supply of the Goods/Services.

30.2 Title to Intellectual Property

- a) All right, title and interest in and to Foreground Intellectual Property prepared, conceived or developed by the Supplier/Service Provider, its researchers, agents and employees shall vest in Transnet and the Supplier/Service Provider acknowledges that it has no claim of any nature in and to the Foreground Intellectual Property. The Supplier/Service Provider shall not at any time during or after the termination or cancellation of this Agreement dispute the validity or enforceability of such Foreground Intellectual Property, or cause to be done any act or anything contesting or in any way impairing or tending to impair any part of that right, title and interest to any of the Foreground Intellectual Property and shall not counsel or assist any person to do so.
- b) Transnet shall be entitled to seek protection in respect of the Foreground Intellectual Property anywhere in the world as it shall decide in its own absolute discretion and the Supplier/Service Provider shall reasonably assist Transnet in attaining and maintaining protection of the Foreground Intellectual Property.

Supply and delivery of OHTE wires as and when required for the Eastern Region for a period of 12 months

- c) Where the Foreground Intellectual Property was created by the Supplier/Service Provider or its researchers, agents and employees and where Transnet elects not to exercise its option to seek protection or decides to discontinue the financial support of the prosecution or maintenance of any such protection, Transnet shall notify the Supplier/Service Provider who shall have the right of first refusal to file or continue prosecution or maintain any such applications and to maintain any protection issuing on the Foreground Intellectual Property.
- d) No consideration shall be paid by Transnet to the Supplier/Service Provider for the assignment of any Foreground Intellectual Property from the Supplier/Service Provider to Transnet, over and above the sums payable in terms of this Agreement. The Supplier/Service Provider undertakes to sign all documents and do all things as may be necessary to effect, record and perfect the assignment of the Foreground Intellectual Property to Transnet.
- e) Subject to anything contrary contained in this Agreement and/or the prior written consent of Transnet [which consent shall not be unreasonably withheld], the Supplier/Service Provider shall under no circumstances be entitled as of right, or to claim the right, to use Transnet's Background Intellectual Property and/or Foreground Intellectual Property.

30.3 Title to Improvements

Any improvements, developments, adaptations and/or modifications to the Foreground Intellectual Property, and any and all new inventions or discoveries, based on or resulting from the use of Transnet's Background Intellectual Property and/or Confidential Information shall be exclusively owned by Transnet. The Supplier/Service Provider shall disclose promptly to Transnet all such improvements, developments, adaptations and/or modifications, inventions or discoveries. The Supplier/Service Provider hereby undertakes to sign all documents and do all things as may be necessary to effect, record and perfect the assignment of such improvements, developments, adaptations and/or modifications, inventions or discoveries to Transnet and the Supplier/Service Provider shall reasonably assist Transnet in attaining, maintaining or documenting ownership and/or protection of the improved Foreground Intellectual Property.

30.4 Unauthorised Use of Confidential Information

The Supplier/Service Provider shall not authorise any party to act on or use in any way any Confidential Information belonging to Transnet whether or not such party is aware of such Confidential Information, and shall promptly notify Transnet of the information if it becomes aware of any party so acting, and shall provide Transnet the information with such assistance as Transnet reasonably requires, at Transnet's cost and expense, to prevent such third party from so acting.

30.5 Unauthorised Use of Intellectual Property

- a) The Supplier/Service Provider agrees to notify Transnet in writing of any conflicting uses of, and applications of registrations of Patents, Designs and Trade Marks or any act of infringement, unfair competition or passing off involving the Intellectual Property of Transnet of which the Supplier/Service Provider acquires knowledge and Transnet shall have the right, as its own option, to proceed against any party infringing its Intellectual Property.
- b) It shall be within the sole and absolute discretion of Transnet to determine what steps shall be taken against the infringer and the Supplier/Service Provider shall co-operate fully with Transnet, at Transnet's cost, in whatever measure including legal action to bring any infringement of illegal use to an end.

Supply and delivery of OHTE wires as and when required for the Eastern Region for a period of 12 months

- c) The Supplier/Service Provider shall cooperate to provide Transnet promptly with all relevant ascertainable facts.
- d) If proceedings are commenced by Transnet alone, Transnet shall be responsible for all expenses but shall be entitled to all damages or other awards arising out of such proceedings. If proceedings are commenced by both Parties, both Parties will be responsible for the expenses and both Parties shall be entitled to damages or other awards arising out of proceedings.

31 NON-WAIVER

- 31.1 Failure or neglect by either Party, at any time, to enforce any of the provisions of this Agreement, shall not in any manner be construed to be a waiver of any of that Party's rights in that regard and in terms of this Agreement.
- 31.2 Such failure or neglect shall not in any manner affect the continued, unaltered validity of this Agreement, or prejudice the right of that Party to institute subsequent action.

32 PARTIAL INVALIDITY

If any provision of this Agreement shall be held to be invalid, illegal or unenforceable, or shall be required to be modified, the validity, legality and enforceability of the remaining provisions shall not be affected thereby.

33 DISPUTE RESOLUTION

- 33.1 Should any dispute of whatsoever nature arise between the Parties concerning this Agreement, the Parties shall try to resolve the dispute by negotiation within 10 [ten] Business Days of such dispute arising.
- 33.2 If the dispute has not been resolved by such negotiation, either of the Parties may refer the dispute to AFSA and notify the other Party accordingly, which proceedings shall be held in Johannesburg.
- 33.3 Such dispute shall be finally resolved in accordance with the rules of AFSA by an arbitrator or arbitrators appointed by AFSA.
- 33.4 This clause constitutes an irrevocable consent by the Parties to any proceedings in terms hereof, and neither of the Parties shall be entitled to withdraw from the provisions of this clause or claim at any such proceedings that it is not bound by this clause 33.
- 33.5 This clause 339 is severable from the rest of this Agreement and shall remain in effect even if this Agreement is terminated for any reason.
- 33.6 This clause 339 shall not preclude either Party from seeking urgent relief in a court of appropriate jurisdiction, where grounds for urgency exist.

34 ADDRESSES FOR NOTICES

34.1 The Parties to this Agreement select the physical addresses and fax numbers, as detailed hereafter, as their respective addresses for giving or sending any notice provided for or required in terms of this Agreement, provided that either Party shall be entitled to substitute such other address or fax number, as may be, by written notice to the other:

- a) **Transnet**
 - (i) For legal notices: [REDACTED]

Supply and delivery of OHTE wires as and when required for the Eastern Region for a period of 12 months

[Redacted]

[Redacted]

Fax No. [Redacted]

Attention: Group Legal Department

(ii) For commercial notices:

[Redacted]

[Redacted]

[Redacted]

Fax No. [Redacted]

Attention: [Redacted]

b) **The Supplier/Service Provider**

(i) For legal notices:

[Redacted]

[Redacted]

[Redacted]

Fax No. [Redacted]

Attention: [Redacted]

(ii) For commercial notices:

[Redacted]

[Redacted]

[Redacted]

Fax No. [Redacted]

Attention: [Redacted]

34.2 Any notice shall be addressed to a Party at its physical address, or delivered by hand, or sent by fax or email.

34.3 Any notice shall be deemed to have been given:

- a) if hand delivered, on the day of delivery;
- b) if faxed, on the date and time of sending of such fax, as evidenced by a fax confirmation printout, provided that such notice shall be confirmed by prepaid registered post on the date of dispatch of such fax, or, should no postal facilities be available on that date, on the next Business Day; or
- c) if sent by email, on the date and time received, provided that such notice shall be confirmed by prepaid registered post on the date of dispatch of such email, or, should no postal facilities be available on that date, on the next Business Day.

35 WHOLE AND ONLY AGREEMENT

35.1 The Parties hereby confirm that this Agreement constitutes the whole and only agreement between them with regard to the subject matter of this Agreement.

35.2 The Parties hereby confirm that this Agreement replaces all other agreements which exist or may have existed in any form whatsoever between them, with regard to the subject matter dealt with in this Agreement, any annexures appended hereto and the Schedule of Requirements/Work Order.

Supply and delivery of OHTE wires as and when required for the Eastern Region for a period of 12 months

36 AMENDMENT AND CHANGE CONTROL

36.1 Any amendment or change of any nature made to this Agreement and the Schedule of Requirements thereof shall only be valid if it is in writing, signed by both Parties and added to this Agreement as an addendum hereto. In this regard a Change Notice must first be defined and issued by the requesting Party. A Change Notice Response must then be issued by responding Party. A formal approval of the Change Request will then trigger the issue of the addendum to this Agreement.

36.2 In the event the Parties cannot agree upon changes, the Parties shall in good faith seek to agree any proposed changes using the dispute resolution procedures in clause 339 [*Dispute Resolution*].

37 GENERAL

37.1 Governing Law

This Agreement is exclusively governed by and construed in accordance with the laws of the Republic of South Africa and is subject to the jurisdiction of the courts of the Republic of South Africa.

37.2 Change of Law

In this Agreement, unless the context otherwise requires, references to a statutory provision include references to that statutory provision as from time to time amended, extended or re-enacted and any regulations made under it, provided that in the event that the amendment, extension or re-enactment of any statutory provision or introduction of any new statutory provision has a material impact on the obligations of either Party, the Parties will negotiate in good faith to agree such amendments to this Agreement as may be appropriate in the circumstances. If, within a reasonable period of time, the Supplier/Service Provider and Transnet cannot reach agreement on the nature of the changes required or on modification of Prices, delivery schedules, warranties, or other terms and conditions, either Party may seek to have the matter determined in accordance with clause 339 [*Dispute Resolution*] above.

37.3 Counterparts

This Agreement may be signed in any number of counterparts, all of which taken together shall constitute one and the same instrument. Either Party may enter into this Agreement by signing any such counterpart.

38 DATABASE OF RESTRICTED SUPPLIER

The process of restriction is used to exclude a company/person from conducting future business with Transnet and other organs of state for a specified period. No Bid shall be awarded to a Bidder whose name (or any of its members, directors, partners or trustees) appear on the Register of Tender Defaulters kept by National Treasury, or who have been placed on National Treasury's List of Restricted Suppliers. Transnet reserves the right to withdraw an award, or cancel a contract concluded with a Bidder should it be established, at any time, that a bidder has been restricted with National Treasury by another government institution.

Supply and delivery of OHTE wires as and when required for the Eastern Region for a period of 12 months

Thus signed by the Parties and witnessed on the following dates and at the following places:

For and on behalf of TRANSNET SOC LTD duly authorised hereto	For and on behalf of duly authorised hereto
Name:	Name:
Position:	Position:
Signature:	Signature:
Date:	Date:
Place:	Place:

AS WITNESS: Name:	AS WITNESS: Name:
Signature:	Signature:

AS WITNESS: Name:	AS WITNESS: Name:
Signature:	Signature:



A Division of Transnet SOC Limited

TECHNOLOGY MANAGEMENT

SPECIFICATION

REQUIREMENTS FOR 160 SQUARE MILLIMETRE ALL ALUMINIUM JUMPER CONDUCTOR

Author: Engineer
Technology Management

T.G. Mangwegape

tumelo.

Approved by: Principal Engineer
Technology Management

S.E. Sibande

Date: 03 September 2020

Circulation Restricted To:

Transnet and Relevant Third Parties

"I acknowledge that this application contains personal information as defined in the Protection of Personal Information Act, 2013 (the "Act"). By accessing/ using this application, I consent to the processing of my personal information in accordance with the requirements of the Act. I acknowledge that I cannot unreasonably withhold my consent. I acknowledge that the purpose for processing my personal information is in terms of this application."

© This document as a whole is protected by copyright. The information herein is the sole property of Transnet SOC Ltd. It may not be used, disclosed or reproduced in part or in whole in any manner whatsoever, except with the written permission of and in a manner permitted by the proprietors.

TABLE OF CONTENTS

1.0 SCOPE	4
2.0 NORMATIVE REFERENCES	4
2.1. IEC STANDARD	4
2.2. SANS STANDARDS	4
3.0 SERVICE CONDITIONS	4
3.1. ENVIRONMENTAL CONDITIONS	4
3.2. MECHANICAL SERVICE CONDITIONS	4
3.3. ELECTRICAL SERVICE CONDITIONS	5
4.0 TECHNICAL REQUIREMENTS	5
5.0 TESTING AND INSPECTIONS	5
6.0 RATING PLATE, MARKINGS AND INSTRUCTION LABELS	5
7.0 DOCUMENTATION REQUIREMENTS	6
8.0 QUALITY ASSURANCE	6
9.0 PACKAGING, STORAGE AND HANDLING	6
10.0 GUARANTEE AND DEFECTS	6
11.0 METHOD OF TENDERING	7
APPENDIX A: TECHNICAL DATA SHEET	8
ANNEXURE B: TECHNICAL DATA SHEET	9

1.0 SCOPE

- 1.1. This specification details Transnet's requirements for the design of the 160 mm² all aluminium conductor to be used as a jumper on overhead track equipment.
- 1.2. The jumper shall be used on the 3kV DC and 25kV AC electrification systems.
- 1.3. This specification contains the schedule of requirements (Annexure A) which shall be completed by the supplier and shall be submitted as part of the tender documents.
- 1.4. This specification contains technical datasheet (Annexure B) which shall be completed by the supplier and shall be submitted as part of the tender documents.

2.0 NORMATIVE REFERENCES

Unless otherwise specified all materials used, equipment developed and supplied shall comply with the latest edition of the relevant International Electro-technical Commission (IEC), International Organization for Standardization (ISO), South African National Standards (SANS) or Transnet publications.

2.1. IEC STANDARD

IEC 60228, Conductors of insulated cables.

2.2. SANS STANDARDS

SANS 182-2, Conductors for overhead electrical transmission lines - Part 2: Stranded aluminium conductor.

SANS 182-3, Conductors for overhead electrical transmission lines - Part 3: Aluminium conductors, steel reinforced.

SANS 9001, Quality management systems – Requirements.

SANS 6282-3, Test methods for bare conductors and conductors of insulated electric cables Part 3: Mechanical tests.

SANS 60287-1-1, Electrical cables – calculation of the current rating Part 1-1: current rating equations (100% load factor) and calculation of losses – general.

3.0 SERVICE CONDITIONS

3.1. ENVIRONMENTAL CONDITIONS

Altitude:	0 - 1800 m above sea level.
Relative humidity:	10% to 90%.
Ambient temperature:	-10° C to +55° C.
Wind pressure:	750 Pa.
Lightning conditions:	20 ground flashes/km ² per annum.
Pollution:	Heavily salt laden with industrial pollutants including diesel- electric locomotive emissions.

3.2. MECHANICAL SERVICE CONDITIONS

- 3.2.1. The jumpers shall withstand severe vibrations as it will be installed on overhead track equipment above rail.

3.3. ELECTRICAL SERVICE CONDITIONS

The conductor shall be used on the following electrical systems in table 1.

Table 1: System voltages

Systems	3kV DC	25kV AC
Lowest voltages	2.4 kV	19 kV
Highest voltages	3.9 kV	30 kV

4.0 TECHNICAL REQUIREMENTS

- 4.1. These technical requirements are for an all-aluminum soft stranded jumper to equalize current between the contact wire, the catenary and the feeder wire.
- 4.2. The material used to design and manufacture the conductor to be as a jumper shall be pure aluminium in H9 condition and should comply with the requirements given in SANS182-2.
- 4.3. The required cross-sectional area of the conductor shall be 160 mm^2 .
- 4.4. The number of strands in a conductor shall be 37.
- 4.5. The diameter of a single strand shall be 2.36 mm flexible class 2 conductor in accordance to IEC 60228.
- 4.6. The layer configuration of the conductor shall be to the sequence of 1-6-12-18/ C-Z-S-Z concentricly, whereby the outmost layer is right hand (Z).
- 4.7. The lay lengths and lay ratios mentioned in clause 4.6 shall conform to SANS 182-1.
- 4.8. The resistance of the conductor shall not be more than $0.178 \Omega/\text{km}$ at 20°C .
- 4.9. The breaking force according to SANS 182-3 shall not be less than 28.9kN.
- 4.10. The conductor current ratings namely: continuous current, 5 minutes rating and 1-minute rating shall be specified on the datasheet.

5.0 TESTING AND INSPECTIONS

- 5.1. Transnet reserves the right to be present at all tests and inspections as called for in this clause.
- 5.2. The responsibility of arranging the tests called for in this clause rests with the successful tenderer.
- 5.3. A Transnet Freight Rail, Technology Management (Electrical Technology) department representative may request any additional test deemed necessary to ensure compliance.
- 5.4. All certificates of the listed tests shall be supplies to TFR Technology Management for verification and inspection.
- 5.5. Test methods to be carried out to determine whether the conductor complies with the technical requirement shall be in accordance to SANS 6283.
- 5.6. Sampling applied shall confirm to section 6 of SANS 182-2.
- 5.7. The tensile strength of the conductor shall be tested.
- 5.8. The elongation of break of the conductor shall be tested.

6.0 RATING PLATE, MARKINGS AND INSTRUCTION LABELS

- 6.1. Each drum shall bear the following information legibly and permanently marked on a firmly cheek of the drum with a letter dimension of not less than 50mm:
 - 6.2. The original equipment manufacturer's trade name or trademark.

-
- 6.3. Reference area (37/2.36, **160**, *mm*², AAC) and material of conductor (Aluminium Jumper conductor).
 - 6.4. Reference area and material of conductor.
 - 6.5. Nominal length in meters.
 - 6.6. Gross mass in kg.
 - 6.7. Dated Batch Number.

7.0 DOCUMENTATION REQUIREMENTS

- 7.1. Drawings and technical documentation shall be submitted with tender.
- 7.2. The manufacturer shall provide one soft copy and two hard copies of the technical specification.
- 7.3. The manufacturer shall provide design and type test certificates to verify conformance to the requirements and these must be submitted with tender documents.
- 7.4. Supplier shall advise how to proceed with the equipment at the end of its operating life, taking into consideration environmental requirements and regulations.

8.0 QUALITY ASSURANCE

- 8.1. The successful tenderer shall maintain a Quality Management System (QMS) based on or certified to ISO 9001.

9.0 PACKAGING, STORAGE AND HANDLING

- 9.1. Unless otherwise specified by the purchaser, the conductor shall be packed on a robust drum or reel that has a barrel of diameter 580 mm.
- 9.2. Where wooden drums or wooden reels are used, the moisture content of the wood used for fabrication of the drums or reels shall not exceed 15% to comply with clause 5.1.3 of SANS 182-2.
- 9.3. Each reel shall bear the following information legibly and indelibly marked on a firmly attached label or printed on a cheek of the reel.

10.0 GUARANTEE AND DEFECTS

- 10.1. The appointed tenderer shall guarantee that the supplied conductor conforms to Transnet's requirements.
- 10.2. The appointed tenderer shall accept liability for makers' defects, which may appear in design, material and workmanship.

11.0 METHOD OF TENDERING

- 11.1. Tenderers shall indicate clause-by-clause compliance document with the specification. This shall take the form of a separate document listing each of the specification's clause and sub-clause numbers, indicating the individual statements of compliance or non-compliance.
- 11.2. Statement of non-compliance shall be motivated by the tenderer, as per 11.1.
- 11.3. Tenderers shall submit comprehensive literature consisting of detailed technical specifications, general constructional details and principal dimensions, maintenance schedules if necessary, datasheets, together with clear illustrations of the equipment offered.
- 11.4. Any items offered in accordance with other standards will be considered at the sole discretion of Transnet Freight Rail, Technology Management, Electrical Technology Department. The tenderer shall supply full details stating where the item differs from these specifications as well as supplying a copy (in English) of the recognized standard specification(s) with which it complies. Any deviations must be approved by the relevant Transnet Freight Rail, Technology Management, Electrical Technology Department in writing.
- 11.5. Failure to comply with clauses 11.1, 11.2, 11.3 and 11.4 could preclude a tenderer from consideration.
- 11.6. In the event of any conflict between the various submitted relevant documents, the order of precedence shall be, and in consultation with Transnet Freight Rail, Technology Management, Electrical Technology Department:
 - a) Legal and safety requirements.
 - b) This Specification.

APPENDIX A: TECHNICAL DATA SHEET

(To be completed by the relevant Transnet Freight Rail Representative)

No.	Details	Values
1	Name of the depot/location	
2	Electrification line type	
3	Name of the conductor	Aluminium Jumper conductor
4	Total required length	
5	Conductor size	37/2.36, 160 mm², AAC

Completed by
Designation
Signature
Date

ANNEXURE B: TECHNICAL DATA SHEET

(To be completed by the supplier and submitted as part of their tender)

No.	Details of the conductor	Values	Unit
a)	Cross-sectional area of the conductor		mm^2
b)	Number of strands		Strands
c)	Conductor Lay ratio		
d)	Conductor breaking force		kN
	Current ratings:		
e)	Continuous rating		A
f)	5 Minutes rating		A
g)	1 Minute rating		A
h)	Resistance per km at 20 degrees		Ohms/km

ANNEXURE D TRANSNET'S GENERAL BID CONDITIONS

GENERAL BID CONDITIONS

[June 2022]

TABLE OF CONTENTS

1 DEFINITIONS3

2 GENERAL3

3 SUBMITTING OF BID DOCUMENTS.....3

4 USE OF BID FORMS3

5 BID FEES4

6 VALIDITY PERIOD.....4

7 SITE VISITS / BRIEFING SESSIONS4

8 CLARIFICATION BEFORE THE CLOSING DATE4

9 COMMUNICATION AFTER THE CLOSING DATE4

10 UNAUTHORISED COMMUNICATION ABOUT BIDS.....4

11 RETURNABLE DOCUMENTS4

12 DEFAULTS BY RESPONDENTS4

13 CURRENCY5

14 PRICES SUBJECT TO CONFIRMATION5

15 ALTERATIONS MADE BY THE RESPONDENT TO BID PRICES5

16 EXCHANGE AND REMITTANCE.....5

17 ACCEPTANCE OF BID.....6

18 NOTICE TO UNSUCCESSFUL RESPONDENTS.....6

19 TERMS AND CONDITIONS OF CONTRACT6

20 CONTRACT DOCUMENTS6

21 LAW GOVERNING CONTRACT.....6

22 IDENTIFICATION7

23 RESPONDENT'S SAMPLES7

24 SECURITIES.....7

25 PRICE AND DELIVERY BASIS FOR GOODS7

26 EXPORT LICENCE8

27 QUALITY OF MATERIAL8

28 VALUE-ADDED TAX8

29 IMPORTANT NOTICE TO RESPONDENTS REGARDING PAYMENT8

30 CONTRACT QUANTITIES AND DELIVERY REQUIREMENTS9

31 PLANS, DRAWINGS, DIAGRAMS, SPECIFICATIONS AND DOCUMENTS10

32 BIDS BY OR ON BEHALF OF FOREIGN RESPONDENTS.....10

33 DATABASE OF RESTRICTED SUPPLIERS11

34 CONFLICT WITH ISSUED RFX DOCUMENT11

1 DEFINITIONS

Where the following words or phrases are used in this Agreement, such words or phrases shall have the meaning assigned thereto in this clause, except where the context clearly requires otherwise:

- 1.1 **Bid** shall mean a Respondent's tendered response / proposal to a Transnet RFP or RFQ;
- 1.2 **Bid Document(s)** shall mean a reference to a Request for Proposal or Request for Quotation;
- 1.3 **Business Day** shall mean any day other than a Saturday, Sunday or public holiday;
- 1.4 **Goods** shall mean the goods required by Transnet as specified in its Bid Document;
- 1.5 **Parties** shall mean Transnet and the Respondents to a Bid Document;
- 1.6 **Respondent(s)** shall mean a respondent/bidder to a Bid Document;
- 1.7 **RFP** shall mean Request for Proposal;
- 1.8 **RFQ** shall mean Request for Quotation;
- 1.9 **RFX** shall mean RFP or RFQ, as the case may be;
- 1.10 **Services** shall mean the services required by Transnet as specified in its Bid Document;
- 1.11 **Service Provider or Supplier** shall mean the successful Respondent;
- 1.12 **Tax Invoice** shall mean the document as required by Section 20 of the Value-Added Tax Act, 89 of 1991, as may be amended from time to time;
- 1.13 **Transnet** shall mean Transnet SOC Ltd, a State Owned Company; and
- 1.14 **VAT** shall mean Value-Added Tax in terms of the Value-Added Tax Act, 89 of 1991, as may be amended from time to time.

2 GENERAL

All Bid Documents and subsequent contracts and orders shall be subject to the following general conditions as laid down by Transnet and are to be strictly adhered to by any Respondent to this RFX.

3 SUBMITTING OF BID DOCUMENTS

- 3.1 A Bid, which shall hereinafter include reference to an RFP or RFQ, shall be submitted to Transnet no later than the closing date and time specified in accordance with the directions issued in the Bid Documents. Late Bids will not be considered.
- 3.2 The Bid Documents must be completed in their entirety and Respondents are required to complete and submit their Bid submissions by uploading them into the system against each tender selected. The bidder guide can be found on the Transnet Portal transnetetenders.azurewebsites.net.

4 USE OF BID FORMS

- 4.1 Where special forms and/or formats are issued by Transnet for the submission of Bids, Respondents are required to submit their Bids by completion of the appropriate sections on such official forms and/or formats and not in other forms and/or formats or documents bearing their own terms and conditions of contract. Non-compliance with this condition may result in the rejection of a Bid.
- 4.2 Respondents must note that the original Bid forms and/or formats must be completed for submission.
- 4.3 Only if insufficient space has been allocated to a particular response may a Respondent submit additional information under separate cover using the Company's letterhead. This must be duly cross-referenced in the RFX.

5 BID FEES

A bid fee is not applicable. The Bid Documents may be downloaded directly from National Treasury's e-Tender Publication Portal at www.etenders.gov.za and may also be downloaded from the Transnet website at www.transnet.net free of charge.

6 VALIDITY PERIOD

- 6.1 The Respondents must hold their Bid valid for acceptance by Transnet at any time within the requested validity period after the closing date of the bid.
- 6.2 Respondents may be requested to extend their validity period for a specified additional period. In such instances, Respondents will not be allowed to change any aspect of their Bid, unless they are able to demonstrate that the proposed change/s is as a direct and unavoidable consequence of Transnet's extension of the validity period.

7 SITE VISITS / BRIEFING SESSIONS

Respondents may be requested to attend a site visit or briefing session where it is necessary to view the site in order to prepare their Bids, or where Transnet deems it necessary to provide Respondents with further information to allow them to complete their Bids properly. Where such visits or sessions are indicated as compulsory in the RFX Document, Respondents are obliged to attend these meetings as failure to do so will result in their disqualification.

8 CLARIFICATION BEFORE THE CLOSING DATE

Should clarification be required on any aspect of the Bid before the closing date, the Respondent must upload questions onto the Transnet e-Tender Submission Portal or direct such queries to the contact person listed in the RFX Document in the stipulated manner.

9 COMMUNICATION AFTER THE CLOSING DATE

After the closing date of a Bid (i.e. during the evaluation period) the Respondent may only communicate with the contact person listed in the RFX Document.

10 UNAUTHORISED COMMUNICATION ABOUT BIDS

Respondents may at any time communicate with the contact person listed in the RFX Document on any matter relating to its Bid but, in the absence of written authority from the delegated individual (BEC chairperson), no communication on a question affecting the subject of a Bid shall take place between Respondents or other potential service providers or any member of the Bid Adjudication Committee or official of Transnet during the period between the closing date for the receipt of the Bid and the date of the notification of the successful Respondent(s). A Bid, in respect of which any such unauthorised communication has occurred, may be disqualified.

11 RETURNABLE DOCUMENTS

All returnable documents listed in the RFX Documents must be submitted with Respondent's Bid. Failure to submit mandatory returnable schedules / documents will result in disqualification. Failure to submit other schedules / documents may result in disqualification.

12 DEFAULTS BY RESPONDENTS

If the Respondent, after it has been notified of the acceptance of its Bid fails to:

- 12.1 enter into a formal contract when called upon to do so within such period as Transnet may specify; or
- 12.2 accept an order in terms of the Bid;
- 12.3 furnish satisfactory security when called upon to do so for the fulfilment of the contract; or
- 12.4 comply with any condition imposed by Transnet,

Transnet may, in any such case, without prejudice to any other legal remedy which it may have, proceed to accept any other Bid or, if it is necessary to do so, call for Bids afresh, and may recover from the defaulting Respondent any additional expense incurred by Transnet in calling for new offers or in accepting a less favourable offer.

13 CURRENCY

All monetary amounts referred to in a Bid response must be in Rand, the currency of the Republic of South Africa [**ZAR**], save to the extent specifically permitted in the RFP.

14 PRICES SUBJECT TO CONFIRMATION

Prices which are quoted subject to confirmation will not be considered.

15 ALTERATIONS MADE BY THE RESPONDENT TO BID PRICES

All alterations made by the Respondent to its Bid price(s) prior to the submission of its Bid Documents must be done by deleting the incorrect figures and words where required and by inserting the correct figures and words against the items concerned. All such alterations must be initialled by the person who signs the Bid Documents. Failure to observe this requirement may result in the particular item(s) concerned being excluded in the matter of the award of the business.

16 EXCHANGE AND REMITTANCE

- 16.1 The Respondent should note that where the whole or a portion of the contract or order value is to be remitted overseas, Transnet shall, if requested to do so by the Supplier/Service Provider, effect payment overseas directly to the foreign principal or manufacturer of such percentage of the contract or order value as may be stipulated by the Respondent in its Bid Documents.
- 16.2 It is Transnet's preference to enter into Rand-based agreements. Transnet would request, therefore, that the Respondent give favourable consideration to obtaining forward exchange cover on the foreign currency portion of the Agreement at a cost that is acceptable to Transnet to protect itself against any currency rate fluctuation risks for the duration of any resulting contract or order.
- 16.3 The Respondent who desires to avail itself of the aforementioned facility must at the time of bidding furnish the information called for in the Exchange and Remittance section of the Bid Documents and also furnish full details of the principals or manufacturer to whom payment is to be made.
- 16.4 The South African Reserve Bank's approval is required before any foreign currency payments can be made to or on behalf of Respondents.
- 16.5 Transnet will not recognise any claim for adjustment of the order and/or contract price if the increase in price arises after the date on which the Goods/Services were to be delivered, as set out in the order and/or contract, or any subsequent agreement between the parties.
- 16.6 Transnet reserves the right to request a pro-forma invoice/tax invoice in order to ensure compliance with the contract and Value-Added Tax Act no. 89 of 1991 [VAT Act].

17 ACCEPTANCE OF BID

- 17.1 Upon the acceptance of a Bid by Transnet, the parties shall be bound by these General Bid Conditions and any contractual terms and/or any schedule of "Special Conditions" or otherwise which form part of the Bid Documents.
- 17.2 Where the Respondent has been informed by Transnet of the acceptance of its Bid, an email communication that has been successfully sent to the Respondent shall be regarded as proof of delivery to the Respondent 1 day after the date of submission.

18 NOTICE TO UNSUCCESSFUL RESPONDENTS

- 18.1 Unsuccessful Respondents shall be advised in writing that their Bids have not been accepted as soon as possible after the closing date of the Bid. On award of business to the successful Respondent all unsuccessful Respondents must be informed of the name of the successful Respondent and of the reason as to why their Bids had been unsuccessful.

19 TERMS AND CONDITIONS OF CONTRACT

- 19.1 The Supplier/Service Provider shall adhere to the Terms and Conditions of Contract issued with the Bid Documents, together with any schedule of "Special Conditions" or otherwise which form part of the Bid Documents.
- 19.2 Should the Respondent find any conditions unacceptable, it should indicate which conditions are unacceptable and offer amendments/ alternatives by written submission on a company letterhead. Any such submission shall be subject to review by Transnet's Legal Counsel who shall determine whether the proposed amendments /alternative(s) are acceptable or otherwise, as the case may be. Respondents will be afforded an opportunity to withdraw an unacceptable deviation, failing which the respondent will be disqualified.

20 CONTRACT DOCUMENTS

- 20.1 The contract documents will comprise these General Bid Conditions, the Terms and Conditions of Contract and any schedule of "Special Conditions" which form part of the Bid Documents.
- 20.2 The abovementioned documents together with the Respondent's Bid response will constitute the contract between the parties upon receipt by the Respondent of Transnet's letter of acceptance, subject to all additional amendments and/or special conditions thereto as agreed to by the parties.
- 20.3 Should Transnet inform the Respondent that a formal contract will be signed, the abovementioned documents together with the Respondent's Bid response [and, if any, its covering letter and any subsequent exchange of correspondence] as well as Transnet's Letter of Acceptance, shall constitute a binding contract until the final contract is signed.

21 LAW GOVERNING CONTRACT

The law of the Republic of South Africa shall govern the contract created by the acceptance of a Bid. The *domicilium citandi et executandi* shall be a place in the Republic of South Africa to be specified by the Respondent in its Bid at which all legal documents may be served on the Respondent who shall agree to submit to the jurisdiction of the courts of the Republic of South Africa. A foreign Respondent shall, therefore, state in its Bid the name of its authorised representative in the Republic of South Africa who is empowered to sign any contract which may be entered into in the event of its Bid being accepted and to act on its behalf in all matters relating to the contract.

22 IDENTIFICATION

If the Respondent is a company, the full names of the directors shall be stated in the Bid. If the Respondent is a close corporation, the full names of the members shall be stated in the Bid. If the Respondent is a partnership or an individual trading under a trade name, the full names of the partners or of such individual, as the case may be, shall be furnished.

23 RESPONDENT'S SAMPLES

- 23.1 If samples are required from Respondents, such samples shall be suitably marked with the Respondent's name and address, the Bid number and the Bid item number and must be despatched in time to reach the addressee as stipulated in the Bid Documents on or before the closing date of the Bid. Failure to submit samples by the due date may result in the rejection of a Bid.
- 23.2 Transnet reserves the right to retain samples furnished by Respondents in compliance with Bid conditions.
- 23.3 Payment will not be made for a successful Respondent's samples that may be retained by Transnet for the purpose of checking the quality and workmanship of Goods/Services delivered in execution of a contract.
- 23.4 If Transnet does not wish to retain unsuccessful Respondents' samples and the Respondents require their return, such samples may be collected by the Respondents at their own risk and cost.

24 SECURITIES

- 24.1 The successful Respondent, when called upon to do so, shall provide security to the satisfaction of Transnet for the due fulfilment of a contract or order. Such security shall be in the form of a Deed of Suretyship [Deed of Suretyship] furnished by an approved bank, building society, insurance or guarantee corporation carrying on business in South Africa.
- 24.2 The security may be applied in whole or part at the discretion of Transnet to make good any loss or damage which Transnet may incur in consequence of a breach of the contract or any part thereof.
- 24.3 Such security, if required, shall be an amount which will be stipulated in the Bid Documents.
- 24.4 For the purpose of clause 24.124.1 above, Transnet will supply a Deed of Suretyship form to the successful Respondent for completion and no guarantee in any other form will be accepted. A copy of such form will be supplied to Respondents on request. For this purpose a Deed of Suretyship form will be provided which shall be completed and returned to Transnet or a designated official by the successful Respondent within 30 [thirty] calendar days from the date of the letter of acceptance. No payment will be made until the form, duly completed, is delivered to Transnet. Failure to return the Deed of Suretyship within the prescribed time shall, save where prior extension has been granted, entitle Transnet without notice to the Supplier/Service Provider to cancel the contract with immediate effect.
- 24.5 Additional costs incurred by Transnet necessitated by reason of default on the part of the Supplier/Service Provider in relation to the conditions of this clause 244 will be for the account of the Supplier/Service Provider.

25 PRICE AND DELIVERY BASIS FOR GOODS

- 25.1 Unless otherwise specified in the Bid Documents, the prices quoted for Goods must be on a Delivered Duty Paid [latest ICC Incoterms] price basis in accordance with the terms and at the delivery point or

points specified in Transnet's Bid Documents. Bids for supply on any other basis of delivery are liable to disqualification. The lead time for delivery stated by the Respondent must be inclusive of all non-working days or holidays, and of periods occupied in stocktaking or in effecting repairs to or overhauling plant, which would ordinarily occur within the delivery period given by the Respondent.

25.2 Respondents must furnish their Bid prices in the Price Schedule of the Bid Documents on the following basis:

- a) Local Supplies - Prices for Goods to be manufactured, produced or assembled in the Republic of South Africa, or imported supplies held in South Africa, to be quoted on a Delivered RSA named destination basis.
- b) Imported Supplies - Prices for Goods to be imported from all sources to be quoted on a Delivered Duty Paid [latest ICC Incoterms] basis, to end destination in South Africa, unless otherwise specified in the Bid Price Schedule.

26 EXPORT LICENCE

The award of a Bid for Goods to be imported may be subject to the issue of an export licence in the country of origin or supply. If required, the Supplier/Service Provider's manufacturer or forwarding agent shall be required to apply for such licence.

27 QUALITY OF MATERIAL

Unless otherwise stipulated, the Goods offered shall be NEW i.e. in unused condition, neither second-hand nor reconditioned.

28 VALUE-ADDED TAX

28.1 In respect of local supplies, i.e. Goods to be manufactured, produced or assembled in the Republic of South Africa, or imported supplies held or already in transit to South Africa, the prices quoted by the Respondent are to be inclusive of VAT which must be shown separately at the standard rate on the Tax Invoice.

28.2 In respect of foreign Services rendered:

- a) the invoicing by a South African Service Provider on behalf of its foreign principal rendering such Service represents a Service rendered by the principal; and
- b) the Service Provider's Tax Invoice(s) for the local portion only [i.e. the "commission" for the Services rendered locally] must show the VAT separately.

29 IMPORTANT NOTICE TO RESPONDENTS REGARDING PAYMENT

29.1 Method of Payment

- a) The attention of the Respondent is directed to the Terms and Conditions of Contract which set out the conditions of payment on which Bid price(s) shall be based.
- b) However, in addition to the foregoing the Respondent is invited to submit offers based on alternative methods of payment and/or financing proposals.
- c) The Respondent is required to give full particulars of the terms that will be applicable to its alternative offer(s) and the financial merits thereof will be evaluated and taken into consideration when the Bid is adjudicated.

- d) The Respondent must, therefore, in the first instance, tender strictly in accordance with clause 29.1 (a) above. Failure to comply with clause 29.1 (a) above may preclude a Bid from further consideration.

NOTE: The successful Respondent [the **Supplier/Service Provider**] shall, where applicable, be required to furnish a guarantee covering any advance payments.

29.2 Conditional Discount

Respondents offering prices which are subject to a conditional discount applicable for payment within a specific period are to note that the conditional period will be calculated as from the date of receipt by Transnet of the Supplier/Service Provider's month-end statement reflecting the relevant Tax Invoice(s) for payment purposes, provided the conditions of the order or contract have been fulfilled and the Tax Invoice is correct in all respects as referred to in the contract or order. Incomplete and/or incorrect Tax Invoices shall be returned and the conditional period will be recalculated from the date of receipt of the correct documentation.

30 CONTRACT QUANTITIES AND DELIVERY REQUIREMENTS

30.1 Contract Quantities

- a) It must be clearly understood that although Transnet does not bind itself to purchase a definitive quantity under any contract which may be entered into pursuant to this Bid, the successful Respondent nevertheless undertakes to supply against the contract such quantities as may be ordered against the contract, which orders are posted or delivered by hand or transmitted electronically on or before the expiry date of such contract.
- b) It is furthermore a condition that Transnet will not accept liability for any material/stocks specially ordered or carried by the Respondent with a view to meeting the requirements under any such contract.
- c) The estimated planned quantities likely to be ordered by Transnet per annum are furnished in relevant section of the Bid Documents. For avoidance of doubt the estimated quantities are estimates and Transnet reserves the right to order only those quantities sufficient for its operational requirements.

30.2 Delivery Period

- a) **Period Contracts and Fixed Quantity Requirements**
It will be a condition of any resulting contract/order that the delivery period embodied therein will be governed by the provisions of the Terms and Conditions of Contract.
- b) **Progress Reports**
The Supplier/Service Provider may be required to submit periodical progress reports with regard to the delivery of the Goods/Services.
- c) **Emergency Demands as and when required**
If, due to unforeseen circumstances, supplies of the Goods/Services covered by the Bid are required at short notice for immediate delivery, the Supplier/Service Provider will be given first right of refusal for such business. If it is unable to meet the desired critical delivery period, Transnet reserves the right to purchase such supplies as may be required to meet the emergency outside the contract if immediate delivery can be offered from any other source.

The *Total or Partial Failure to Perform the Scope of Supply* section in the Terms and Conditions of Contract will not be applicable in these circumstances.

31 PLANS, DRAWINGS, DIAGRAMS, SPECIFICATIONS AND DOCUMENTS

31.1 Copyright

Copyright in plans, drawings, diagrams, specifications and documents compiled by the Supplier/Service Provider for the purpose of contract work shall be governed by the Intellectual Property Rights section in the Terms and Conditions of Contract.

31.2 Drawings and specifications

In addition to what may be stated in any Bid Document, the Respondent should note that, unless notified to the contrary by Transnet or a designated official by means of an official amendment to the Bid Documents, it is required to tender for Goods/Services strictly in accordance with the drawings and/or specifications supplied by Transnet, notwithstanding that it may be aware that alterations or amendments to such drawings or specifications are contemplated by Transnet.

31.3 Respondent's drawings

Drawings required to be submitted by the Respondent must be furnished before the closing time and date of the Bid. The non-receipt of such drawings by the appointed time may disqualify the Bid.

31.4 Foreign specifications

The Respondent quoting for Goods/Services in accordance with foreign specifications, other than British and American standards, is to submit translated copies of such specifications with the Bid. In the event of any departures or variations between the foreign specification(s) quoted in the Bid Documents, full details regarding such departures or variations must be furnished by the Respondent in a covering letter attached to the Bid. Non-compliance with this condition may result in disqualification.

32 BIDS BY OR ON BEHALF OF FOREIGN RESPONDENTS

32.1 Bids submitted by foreign principals may be forwarded directly by the principals or by its South African representative or agent to the designated official of Transnet according to whichever officer is specified in the Bid Documents.

32.2 In the case of a representative or agent, written proof must be submitted to the effect that such representative or agent has been duly authorised to act in that capacity by the principal. Failure to submit such authorisation by the representative or agent shall disqualify the Bid.

32.3 When legally authorised to prepare and submit Bids on behalf of their principals not domiciled in the Republic of South Africa, representatives or agents must compile the Bids in the names of such principals and sign them on behalf of the latter.

32.4 South African representatives or agents of a successful foreign Respondent must when so required enter into a formal contract in the name of their principals and must sign such contract on behalf of the latter. In every such case a legal Power of Attorney from their principals must be furnished to Transnet by the South African representative or agents authorising them to enter into and sign such contract.

a) Such Power of Attorney must comply with Rule 63 (Authentication of documents executed outside the Republic for use within the Republic) of the Uniform Rules of Court: Rules

regulating the conduct of the proceedings of the several provincial and local divisions of the Supreme Court of South Africa.

- b) The Power of Attorney must be signed by the principal under the same title as used in the Bid Documents.
- c) If a Power of Attorney held by the South African representative or agent includes matters of a general nature besides provision for the entering into and signing of a contract with Transnet, a certified copy thereof should be furnished.
- d) The Power of Attorney must authorise the South African representative or agent to choose the *domicilium citandi et executandi*.

32.5 If payment is to be made in South Africa, the foreign Supplier/Service Provider [i.e. the principal, or its South African agent or representative], must notify Transnet in writing whether, for payment by electronic funds transfer [EFT]:

- a) funds are to be transferred to the credit of the foreign Supplier/Service Provider's account at a bank in South Africa, in which case the name and branch of such bank shall be furnished; or
- b) funds are to be transferred to the credit of its South African agent or representative, in which case the name and branch of such bank shall be furnished.

32.6 The attention of the Respondent is directed to clause 24 above [Securities] regarding the provision of security for the fulfilment of contracts and orders and the manner and form in which such security is to be furnished.

33 DATABASE OF RESTRICTED SUPPLIERS

The process of restriction is used to exclude a company/person from conducting future business with Transnet and other organs of state for a specified period. No Bid shall be awarded to a Bidder whose name (or any of its members, directors, partners or trustees) appear on the Register of Tender Defaulters kept by National Treasury, or who have been placed on National Treasury's List of Restricted Suppliers. Transnet reserves the right to withdraw an award, or cancel a contract concluded with a Bidder should it be established, at any time, that a bidder has been restricted with National Treasury by another government institution.

34 CONFLICT WITH ISSUED RFX DOCUMENT

34.1 Should a conflict arise between these General Bid Conditions and the issued RFX document, the conditions stated in the RFX document shall prevail.

oooOOOooo



ANNEXURE E TRANSNET'S SUPPLIER INTEGRITY PACT

INTEGRITY PACT

Between

TRANSNET SOC LTD

Registration Number: 1990/000900/30

("Transnet")

And The Bidder / Supplier/ Service Provider / Contractor (hereinafter referred to as the "Bidder / Supplier")

PREAMBLE

Transnet values full compliance with all relevant laws and regulations, ethical standards and the principles of economical use of resources, fairness and transparency in its relations with its Bidders / Suppliers.

In order to achieve these goals, Transnet and the Bidder / Supplier hereby enter into this agreement hereinafter referred to as the "Integrity Pact" which will form part of the Bidder's / Supplier's application for registration with Transnet as a vendor.

The general purpose of this Integrity Pact is to agree on avoiding all forms of dishonesty, fraud and corruption by following a system that is fair, transparent and free from any undue influence prior to, during and subsequent to the currency of any procurement and / or reverse logistics event and any further contract to be entered into between the Parties, relating to such event.

All Bidders / Suppliers will be required to sign and comply with undertakings contained in this Integrity Pact, should they want to be registered as a Transnet vendor.

1 OBJECTIVES

- 1.1 Transnet and the Bidder / Supplier agree to enter into this Integrity Pact, to avoid all forms of dishonesty, fraud and corruption including practices that are anti-competitive in nature, negotiations made in bad faith and under-pricing by following a system that is fair, transparent and free from any influence / unprejudiced dealings prior to, during and subsequent to the currency of the contract to be entered into with a view to:
 - a) Enable Transnet to obtain the desired contract at a reasonable and competitive price in conformity to the defined specifications of the works, goods and services; and
 - b) Enable Bidders / Suppliers to abstain from bribing or participating in any corrupt practice in order to secure the contract.

2 COMMITMENTS OF TRANSNET

Transnet commits to take all measures necessary to prevent dishonesty, fraud and corruption and to observe the following principles:

- 2.1 Transnet hereby undertakes that no employee of Transnet connected directly or indirectly with the sourcing event and ensuing contract, will demand, take a promise for or accept directly or through intermediaries any bribe, consideration, gift, reward, favour or any material or immaterial benefit or any other advantage from the Bidder, either for themselves or for any person, organisation or third party related to the contract in exchange for an advantage in the bidding process, bid evaluation, contracting or implementation process related to any contract.
- 2.2 Transnet will, during the registration and bidding process treat all Bidders / Suppliers with equity, transparency and fairness. Transnet will in particular, before and during the registration process, provide to all Bidders / Suppliers the same information and will not provide to any Bidders / Suppliers confidential / additional information through which the Bidders / Suppliers could obtain an advantage in relation to any bidding process.
- 2.3 Transnet further confirms that its employees will not favour any prospective bidder in any form that could afford an undue advantage to a particular bidder during the tendering stage, and will further treat all Bidders / Supplier participating in the bidding process in a fair manner.
- 2.4 Transnet will exclude from the bidding process such employees who have any personal interest in the Bidders / Suppliers participating in the bidding process.

3 OBLIGATIONS OF THE BIDDER / SUPPLIER

- 3.1 Transnet has a '**Zero Gifts**' Policy. No employee is allowed to accept gifts, favours or benefits.
- a) Transnet officials and employees **shall not** solicit, give or accept, or from agreeing to solicit, give, accept or receive directly or indirectly, any gift, gratuity, favour, entertainment, loan, or anything of monetary value, from any person or juridical entities in the course of official duties or in connection with any operation being managed by, or any transaction which may be affected by the functions of their office.
 - b) Transnet officials and employees **shall not** solicit or accept gifts of any kind, from vendors, suppliers, customers, potential employees, potential vendors, and suppliers, or any other individual or organisation irrespective of the value.
 - c) Under **no circumstances** should gifts, business courtesies or hospitality packages be accepted from or given to prospective suppliers participating in a tender process at the respective employee's Operating Division, regardless of retail value.
 - d) Gratuities, bribes or kickbacks of any kind must never be solicited, accepted or offered, either directly or indirectly. This includes money, loans, equity, special privileges, personal favours, benefit or services. Such favours will be considered to constitute corruption.
- 3.2 The Bidder / Supplier commits itself to take all measures necessary to prevent corrupt practices, unfair means and illegal activities during any stage of its bid or during any ensuing contract stage in order to secure the contract or in furtherance to secure it and in particular the Bidder / Supplier commits to the following:
- a) The Bidder / Supplier will not, directly or through any other person or firm, offer, promise or give to Transnet or to any of Transnet's employees involved in the bidding process or to any third person any material or other benefit or payment, in order to obtain in exchange an advantage during the bidding process; and
 - b) The Bidder / Supplier will not offer, directly or through intermediaries, any bribe, gift, consideration, reward, favour, any material or immaterial benefit or other advantage, commission, fees, brokerage or inducement to any employee of Transnet, connected directly or indirectly with the bidding process, or to any person, organisation or third party related to the contract in exchange for any advantage in the bidding, evaluation, contracting and implementation of the contract.
- 3.3 The Bidder / Supplier will not collude with other parties interested in the contract to preclude a competitive bid price, impair the transparency, fairness and progress of the bidding process, bid evaluation, contracting and implementation of the contract. The Bidder / Supplier further commits itself to delivering against all agreed upon conditions as stipulated within the contract.
- 3.4 The Bidder / Supplier will not enter into any illegal or dishonest agreement or understanding, whether formal or informal with other Bidders / Suppliers. This applies in particular to certifications, submissions or non-submission of documents or actions that are restrictive or to introduce cartels into the bidding process.
- 3.5 The Bidder / Supplier will not commit any criminal offence under the relevant anti-corruption laws of South Africa or any other country. Furthermore, the Bidder /Supplier will not use for illegitimate purposes or for restrictive purposes or personal gain, or pass on to others, any information provided by Transnet as part of the business relationship, regarding plans, technical proposals and business details, including information contained or transmitted electronically.
- 3.6 A Bidder / Supplier of foreign origin shall disclose the name and address of its agents or representatives in South Africa, if any, involved directly or indirectly in the registration or bidding process. Similarly, the Bidder / Supplier of South African nationality shall furnish the name and address of the foreign principals, if any, involved directly or indirectly in the registration or bidding process.
- 3.7 The Bidder / Supplier will not misrepresent facts or furnish false or forged documents or information in order to influence the bidding process to the advantage of the Bidder / Supplier or detriment of Transnet or other competitors.

- 3.8 Transnet may require the Bidder / Supplier to furnish Transnet with a copy of its code of conduct. Such code of conduct must address the compliance programme for the implementation of the code of conduct and reject the use of bribes and other dishonest and unethical conduct.
- 3.9 The Bidder / Supplier will not instigate third persons to commit offences outlined above or be an accessory to such offences.
- 3.10 The Bidder/Supplier confirms that they will uphold the ten principles of the United Nations Global Compact (UNGC) in the fields of Human Rights, Labour, Anti-Corruption and the Environment when undertaking business with Transnet as follows:
- a) Human Rights
 - Principle 1: Businesses should support and respect the protection of internationally proclaimed human rights; and
 - Principle 2: make sure that they are not complicit in human rights abuses.
 - b) Labour
 - Principle 3: Businesses should uphold the freedom of association and the effective recognition of the right to collective bargaining;
 - Principle 4: the elimination of all forms of forced and compulsory labour;
 - Principle 5: the effective abolition of child labour; and
 - Principle 6: the elimination of discrimination in respect of employment and occupation.
 - c) Environment
 - Principle 7: Businesses should support a precautionary approach to environmental challenges;
 - Principle 8: undertake initiatives to promote greater environmental responsibility; and
 - Principle 9: encourage the development and diffusion of environmentally friendly technologies.
 - d) Anti-Corruption
 - Principle 10: Businesses should work against corruption in all its forms, including extortion and bribery.

4 INDEPENDENT BIDDING

- 4.1 For the purposes of this undertaking in relation to any submitted Bid, the Bidder declares to fully understand that the word "competitor" shall include any individual or organisation, other than the Bidder, whether or not affiliated with the Bidder, who:
- a) has been requested to submit a Bid in response to this Bid invitation;
 - b) could potentially submit a Bid in response to this Bid invitation, based on their qualifications, abilities or experience; and
 - c) provides the same Goods and Services as the Bidder and/or is in the same line of business as the Bidder.
- 4.2 The Bidder has arrived at his submitted Bid independently from, and without consultation, communication, agreement or arrangement with any competitor. However communication between partners in a joint venture or consortium will not be construed as collusive bidding.
- 4.3 In particular, without limiting the generality of paragraph 4.2 above, there has been no consultation, communication, agreement or arrangement with any competitor regarding:
- a) prices;
 - b) geographical area where Goods or Services will be rendered [market allocation];
 - c) methods, factors or formulas used to calculate prices;
 - d) the intention or decision to submit or not to submit, a Bid;

- e) the submission of a Bid which does not meet the specifications and conditions of the RFP; or
 - f) bidding with the intention of not winning the Bid.
- 4.4 In addition, there have been no consultations, communications, agreements or arrangements with any competitor regarding the quality, quantity, specifications and conditions or delivery particulars of the Goods or Services to which his/her Bid relates.
- 4.5 The terms of the Bid as submitted have not been, and will not be, disclosed by the Bidder, directly or indirectly, to any competitor, prior to the date and time of the official Bid opening or of the awarding of the contract.
- 4.6 Bidders are aware that, in addition and without prejudice to any other remedy provided to combat any restrictive practices related to bids and contracts, Bids that are suspicious will be reported to the Competition Commission for investigation and possible imposition of administrative penalties in terms of section 59 of the Competition Act No 89 of 1998 and/or may be reported to the National Prosecuting Authority [**NPA**] for criminal investigation and/or may be restricted from conducting business with the public sector for a period not exceeding 10 [ten] years in terms of the Prevention and Combating of Corrupt Activities Act No 12 of 2004 or any other applicable legislation.

5 DISQUALIFICATION FROM BIDDING PROCESS

- 5.1 If the Bidder / Supplier has committed a transgression through a violation of paragraph 3 of this Integrity Pact or in any other form such as to put its reliability or credibility as a Bidder / Supplier into question, Transnet may reject the Bidder's / Supplier's application from the registration or bidding process and remove the Bidder / Supplier from its database, if already registered.
- 5.2 If the Bidder / Supplier has committed a transgression through a violation of paragraph 3, or any material violation, such as to put its reliability or credibility into question, Transnet may after following due procedures and at its own discretion also exclude the Bidder / Supplier from future bidding processes. The imposition and duration of the exclusion will be determined by the severity of the transgression. The severity will be determined by the circumstances of the case, which will include amongst others the number of transgressions, the position of the transgressors within the company hierarchy of the Bidder / Supplier and the amount of the damage. The exclusion will be imposed for up to a maximum of 10 (ten) years. However, Transnet reserves the right to impose a longer period of exclusion, depending on the gravity of the misconduct.
- 5.3 If the Bidder / Supplier can prove that it has restored the damage caused by it and has installed a suitable corruption prevention system, or taken other remedial measures as the circumstances of the case may require, Transnet may at its own discretion revoke the exclusion or suspend the imposed penalty.

6 DATABASE OF RESTRICTED SUPPLIERS

- 6.1 The process of restriction is used to exclude a company/person from conducting future business with Transnet and other organs of state for a specified period. No Bid shall be awarded to a Bidder whose name (or any of its members, directors, partners or trustees) appear on the Register of Tender Defaulters kept by National Treasury, or who have been placed on National Treasury's List of Restricted Suppliers. Transnet reserves the right to withdraw an award, or cancel a contract concluded with a Bidder should it be established, at any time, that a bidder has been restricted with National Treasury by another government institution.
- 6.2 All the stipulations on Transnet's restriction process as laid down in Transnet's Supply Chain Policy and Procurement Procedures Manual are included herein by way of reference. Below follows a condensed summary of this restriction procedure.
- 6.3 On completion of the restriction procedure, Transnet will submit the restricted entity's details (including the identity number of the individuals and registration number of the entity) to National Treasury for placement on National Treasury's Database of Restricted Suppliers for the specified period of exclusion. National

Treasury will make the final decision on whether to restrict an entity from doing business with any organ of state for a period not exceeding 10 years and place the entity concerned on the Database of Restricted Suppliers published on its official website.

- 6.4 The decision to restrict is based on one of the grounds for restriction. The standard of proof to commence the restriction process is whether a "*prima facie*" (i.e. on the face of it) case has been established.
- 6.5 Depending on the seriousness of the misconduct and the strategic importance of the Goods/Services, in addition to restricting a company/person from future business, Transnet may decide to terminate some or all existing contracts with the company/person as well.
- 6.6 A supplier or contractor to Transnet may not subcontract any portion of the contract to a restricted company.
- 6.7 Grounds for restriction include: If any person/Enterprise which has submitted a Bid, concluded a contract, or, in the capacity of agent or subcontractor, has been associated with such Bid or contract:
- a) Has, in bad faith, withdrawn such Bid after the advertised closing date and time for the receipt of Bids;
 - b) has, after being notified of the acceptance of his Bid, failed or refused to sign a contract when called upon to do so in terms of any condition forming part of the bid documents;
 - c) has carried out any contract resulting from such bid in an unsatisfactory manner or has breached any condition of the contract;
 - d) has offered, promised or given a bribe in relation to the obtaining or execution of the contract;
 - e) has acted in a fraudulent or improper manner or in bad faith towards Transnet or any Government Department or towards any public body, Enterprise or person;
 - f) has made any incorrect statement in a certificate or other communication with regard to the Local Content of his Goods or his B-BBEE status and is unable to prove to the satisfaction of Transnet that:
 - (i) he made the statement in good faith honestly believing it to be correct; and
 - (ii) before making such statement he took all reasonable steps to satisfy himself of its correctness;
 - g) has submitted false information regarding any other matter required in terms of the Preferential Procurement Regulations, 2017 issued in terms of the Preferential Procurement Policy Framework Act which will affect the evaluation of a Bid or where a Bidder has failed to declare any subcontracting arrangements;
 - h) caused Transnet damage, or to incur costs in order to meet the contractor's requirements and which could not be recovered from the contractor;
 - i) has litigated against Transnet in bad faith.

7 PREVIOUS TRANSGRESSIONS

- 7.1 The Bidder / Supplier hereby declares that no previous transgressions resulting in a serious breach of any law, including but not limited to, corruption, fraud, theft, extortion and contraventions of the Competition Act 89 of 1998, which occurred in the last 5 (five) years with any other public sector undertaking, government department or private sector company that could justify its exclusion from its registration on the Bidder's / Supplier's database or any bidding process.
- 7.2 If it is found to be that the Bidder / Supplier made an incorrect statement on this subject, the Bidder / Supplier can be rejected from the registration process or removed from the Bidder / Supplier database, if already registered, for such reason (refer to the Breach of Law Form contained in the applicable RFX document.)

8 SANCTIONS FOR VIOLATIONS

- 8.1 Transnet shall also take all or any one of the following actions, wherever required to:
- a) Immediately exclude the Bidder / Supplier from the bidding process or call off the pre-contract negotiations without giving any compensation to the Bidder / Supplier. However, the proceedings with the other Bidders / Suppliers may continue;
 - b) Immediately cancel the contract, if already awarded or signed, without giving any compensation to the Bidder / Supplier;
 - c) Recover all sums already paid by Transnet;
 - d) Encash the advance bank guarantee and performance bond or warranty bond, if furnished by the Bidder / Supplier, in order to recover the payments, already made by Transnet, along with interest;
 - e) Cancel all or any other contracts with the Bidder / Supplier;
 - f) Exclude the Bidder / Supplier from entering into any bid with Transnet and other organs of state in future for a specified period; and
 - g) If the Supplier subcontracted a portion of the bid to another person without declaring it to Transnet, Transnet must penalise the Supplier up to 10% of the value of the contract.

9 CONFLICTS OF INTEREST

- 9.1 A conflict of interest includes, inter alia, a situation in which:
- a) A Transnet employee has a personal financial interest in a bidding / supplying entity; and
 - b) A Transnet employee has private interests or personal considerations or has an affiliation or a relationship which affects, or may affect, or may be perceived to affect his / her judgment in action in the best interest of Transnet, or could affect the employee's motivations for acting in a particular manner, or which could result in, or be perceived as favouritism or nepotism.
- 9.2 A Transnet employee uses his / her position, or privileges or information obtained while acting in the capacity as an employee for:
- a) Private gain or advancement; or
 - b) The expectation of private gain, or advancement, or any other advantage accruing to the employee must be declared in a prescribed form.

Thus, conflicts of interest of any bid committee member or any person involved in the sourcing process must be declared in a prescribed form.

- 9.3 If a Bidder / Supplier has or becomes aware of a conflict of interest i.e. a family, business and / or social relationship between its owner(s) / member(s) / director(s) / partner(s) / shareholder(s) and a Transnet employee / member of Transnet's Board of Directors in respect of a bid which will be considered for the bid process, the Bidder / Supplier:
- a) must disclose the interest and its general nature, in the Request for Proposal ("RFX") declaration form; or
 - b) must notify Transnet immediately in writing once the circumstances has arisen.
- 9.4 The Bidder / Supplier shall not lend to or borrow any money from or enter into any monetary dealings or transactions, directly or indirectly, with any committee member or any person involved in the sourcing process, where this is done, Transnet shall be entitled forthwith to rescind the contract and all other contracts with the Bidder / Supplier.

10 DISPUTE RESOLUTION

10.1 Transnet recognises that trust and good faith are pivotal to its relationship with its Bidders / Suppliers. When a dispute arises between Transnet and its Bidder / Supplier, the parties should use their best endeavours to resolve the dispute in an amicable manner, whenever possible. Litigation in bad faith negates the principles of trust and good faith on which commercial relationships are based. Accordingly, following a restriction process as mentioned in paragraph 6 above, Transnet will not do business with a company that litigates against it in bad faith or is involved in any action that reflects bad faith on its part. Litigation in bad faith includes, but is not limited to the following instances:

- a) **Vexatious proceedings:** these are frivolous proceedings which have been instituted without proper grounds;
- b) **Perjury:** where a supplier make a false statement either in giving evidence or on an affidavit;
- c) **Scurrilous allegations:** where a supplier makes allegations regarding a senior Transnet employee which are without proper foundation, scandalous, abusive or defamatory; and
- d) **Abuse of court process:** when a supplier abuses the court process in order to gain a competitive advantage during a bid process.

11 GENERAL

11.1 This Integrity Pact is governed by and interpreted in accordance with the laws of the Republic of South Africa.

11.2 The actions stipulated in this Integrity Pact are without prejudice to any other legal action that may follow in accordance with the provisions of the law relating to any civil or criminal proceedings.

11.3 The validity of this Integrity Pact shall cover all the bidding processes and will be valid for an indefinite period unless cancelled by either Party.

11.4 Should one or several provisions of this Integrity Pact turn out to be invalid the remainder of this Integrity Pact remains valid.

11.5 Should a Bidder / Supplier be confronted with dishonest, fraudulent or corruptive behaviour of one or more Transnet employees, Transnet expects its Bidders / Suppliers to report this behaviour directly to a senior Transnet official / employee or alternatively by using Transnet's "Tip-Off Anonymous" hotline number 0800 003 056, whereby your confidentiality is guaranteed.

The Parties hereby declare that each of them has read and understood the clauses of this Integrity Pact and shall abide by it. To the best of the Parties' knowledge and belief, the information provided in this Integrity Pact is true and correct.

oooOOOooo

ANNEXURE F NON-DISCLOSURE AGREEMENT

NON DISCLOSURE AGREEMENT

[April 2020]

THIS AGREEMENT is made between

Transnet SOC Ltd [Transnet] [Registration No. 1990/000900/30]

whose registered office is at 49th Floor, Carlton Centre, 150 Commissioner Street, Johannesburg 2001,

and

the Company as indicated in the RFP bid response hereto

WHEREAS

Transnet and the Company wish to exchange Information [as defined below] and it is envisaged that each party may from time to time receive Information relating to the other in respect thereof. In consideration of each party making available to the other such Information, the parties jointly agree that any dealings between them shall be subject to the terms and conditions of this Agreement which themselves will be subject to the parameters of the Bid Document.

IT IS HEREBY AGREED

1. INTERPRETATION

In this Agreement:

- 1.1 **Agents** mean directors, officers, employees, agents, professional advisers, contractors or sub-contractors, or any Group member;
- 1.2 **Bid or Bid Document** means Transnet's Request for Information [**RFI**] Request for Proposal [**RFP**] or Request for Quotation [**RFQ**], as the case may be;
- 1.3 **Confidential Information** means any information or other data relating to one party [the **Disclosing Party**] and/or the business carried on or proposed or intended to be carried on by that party and which is made available for the purposes of the Bid to the other party [the **Receiving Party**] or its Agents by the Disclosing Party or its Agents or recorded in agreed minutes following oral disclosure and any other information otherwise made available by the Disclosing Party or its Agents to the Receiving Party or its Agents, whether before, on or after the date of this Agreement, and whether in writing or otherwise, including any information, analysis or specifications derived from, containing or reflecting such information but excluding information which:
 - 1.3.1 is publicly available at the time of its disclosure or becomes publicly available [other than as a result of disclosure by the Receiving Party or any of its Agents contrary to the terms of this Agreement]; or
 - 1.3.2 was lawfully in the possession of the Receiving Party or its Agents [as can be demonstrated by its written records or other reasonable evidence] free of any restriction as to its use or disclosure prior to its being so disclosed; or

- 1.3.3 following such disclosure, becomes available to the Receiving Party or its Agents [as can be demonstrated by its written records or other reasonable evidence] from a source other than the Disclosing Party or its Agents, which source is not bound by any duty of confidentiality owed, directly or indirectly, to the Disclosing Party in relation to such information;
- 1.4 **Group** means any subsidiary, any holding company and any subsidiary of any holding company of either party; and
- 1.5 **Information** means all information in whatever form including, without limitation, any information relating to systems, operations, plans, intentions, market opportunities, know-how, trade secrets and business affairs whether in writing, conveyed orally or by machine-readable medium.

2. CONFIDENTIAL INFORMATION

- 2.1 All Confidential Information given by one party to this Agreement [the **Disclosing Party**] to the other party [the **Receiving Party**] will be treated by the Receiving Party as secret and confidential and will not, without the Disclosing Party's written consent, directly or indirectly communicate or disclose [whether in writing or orally or in any other manner] Confidential Information to any other person other than in accordance with the terms of this Agreement.
- 2.2 The Receiving Party will only use the Confidential Information for the sole purpose of technical and commercial discussions between the parties in relation to the Bid or for the subsequent performance of any contract between the parties in relation to the Bid.
- 2.3 Notwithstanding clause 2.1 above, the Receiving Party may disclose Confidential Information:
- 2.3.1 to those of its Agents who strictly need to know the Confidential Information for the sole purpose set out in clause 2.2 above, provided that the Receiving Party shall ensure that such Agents are made aware prior to the disclosure of any part of the Confidential Information that the same is confidential and that they owe a duty of confidence to the Disclosing Party. The Receiving Party shall at all times remain liable for any actions of such Agents that would constitute a breach of this Agreement; or
- 2.3.2 to the extent required by law or the rules of any applicable regulatory authority, subject to clause 2.4 below.
- 2.4 In the event that the Receiving Party is required to disclose any Confidential Information in accordance with clause 2.3.2 above, it shall promptly notify the Disclosing Party and cooperate with the Disclosing Party regarding the form, nature, content and purpose of such disclosure or any action which the Disclosing Party may reasonably take to challenge the validity of such requirement.
- 2.5 In the event that any Confidential Information shall be copied, disclosed or used otherwise than as permitted under this Agreement then, upon becoming aware of the same, without prejudice to any rights or remedies of the Disclosing Party, the Receiving Party shall as soon as practicable notify the Disclosing Party of such event and if requested take such steps [including the institution of legal proceedings] as shall be necessary to remedy [if capable of remedy] the default and/or to prevent further unauthorised copying, disclosure or use.
- 2.6 All Confidential Information shall remain the property of the Disclosing Party and its disclosure shall not confer on the Receiving Party any rights, including intellectual property rights over the Confidential Information whatsoever, beyond those contained in this Agreement.

3. RECORDS AND RETURN OF INFORMATION

- 3.1 The Receiving Party agrees to ensure proper and secure storage of all Information and any copies thereof.
- 3.2 The Receiving Party shall keep a written record, to be supplied to the Disclosing Party upon request, of the Confidential Information provided and any copies made thereof and, so far as is reasonably practicable, of the location of such Confidential Information and any copies thereof.
- 3.3 The Company shall, within 7 [seven] days of receipt of a written demand from Transnet:
- 3.3.1 return all written Confidential Information [including all copies]; and
- 3.3.2 expunge or destroy any Confidential Information from any computer, word processor or other device whatsoever into which it was copied, read or programmed by the Company or on its behalf.
- 3.4 The Company shall on request supply a certificate signed by a director as to its full compliance with the requirements of clause 3.3.2 above.

4. ANNOUNCEMENTS

- 4.1 Neither party will make or permit to be made any announcement or disclosure of its prospective interest in the Bid without the prior written consent of the other party.
- 4.2 Neither party shall make use of the other party's name or any information acquired through its dealings with the other party for publicity or marketing purposes without the prior written consent of the other party.

5. DURATION

The obligations of each party and its Agents under this Agreement shall survive the termination of any discussions or negotiations between the parties regarding the Bid and continue thereafter for a period of 5 [five] years.

6. PRINCIPAL

Each party confirms that it is acting as principal and not as nominee, agent or broker for any other person and that it will be responsible for any costs incurred by it or its advisers in considering or pursuing the Bid and in complying with the terms of this Agreement.

7. ADEQUACY OF DAMAGES

Nothing contained in this Agreement shall be construed as prohibiting the Disclosing Party from pursuing any other remedies available to it, either at law or in equity, for any such threatened or actual breach of this Agreement, including specific performance, recovery of damages or otherwise.

8. PRIVACY AND DATA PROTECTION

- 8.1 The Receiving Party undertakes to comply with South Africa's general privacy protection in terms Section 14 of the Bill of Rights in connection with this Bid and shall procure that its personnel shall observe the provisions of such Act [as applicable] or any amendments and re-enactments thereof and any regulations made pursuant thereto.
- 8.2 The Receiving Party warrants that it and its Agents have the appropriate technical and organisational measures in place against unauthorised or unlawful processing of data relating to the Bid and against accidental loss or destruction of, or damage to such data held or processed by them.

9. GENERAL

- 9.1 Neither party may assign the benefit of this Agreement, or any interest hereunder, except with the prior written consent of the other, save that Transnet may assign this Agreement at any time to any member of the Transnet Group.
- 9.2 No failure or delay in exercising any right, power or privilege under this Agreement will operate as a waiver of it, nor will any single or partial exercise of it preclude any further exercise or the exercise of any right, power or privilege under this Agreement or otherwise.
- 9.3 The provisions of this Agreement shall be severable in the event that any of its provisions are held by a court of competent jurisdiction or other applicable authority to be invalid, void or otherwise unenforceable, and the remaining provisions shall remain enforceable to the fullest extent permitted by law.
- 9.4 This Agreement may only be modified by a written agreement duly signed by persons authorised on behalf of each party.
- 9.5 Nothing in this Agreement shall constitute the creation of a partnership, joint venture or agency between the parties.
- 9.6 This Agreement will be governed by and construed in accordance with South African law and the parties irrevocably submit to the exclusive jurisdiction of the South African courts.

oooOOooo