

PRIVATE SPECIFICATION

Prepared for the



SOUTH AFRICAN AIRWAYS

A STAR ALLIANCE MEMBER 

FDC LADIES CLOSED NECK LONG AND SHORT SLEEVED SHIRTS



Item Number: FL44 & FL45
Document Number: SAA 028
Version 03.0/September 2015

1. Scope

This specification¹ covers the material, cut and make of long and short sleeved shirts for female Flight Deck Crew of the South African Airways. The garment variations covered in this specification are as given in table 1.

Table 1 – Garment variations

Type			Item Number
1.1	Long sleeve	FDC shirts	FL45
1.2	Short sleeve		FL44

2. Definitions and Abbreviations

For the purpose of this specification the definitions given in SANS 10371 "Terms and definitions for clothing" and the following shall apply:

acceptable: acceptable to the South African Airways

nominal: subject to the tolerances normal to good manufacturing practice

SANS: South African National Standard

3. Style

The style is as follows:

- ◆ closed-neck shirt
- ◆ cut-on buttonhole stand
- ◆ two-piece collar
- ◆ shoulder straps
- ◆ one badge tab on the left forepart above the pocket
- ◆ bust darts
- ◆ two breast pockets
 - pockets to have square bottom corners
 - have flaps with square bottom corners
 - fastens with buttons and buttonholes
- ◆ plain back
- ◆ one-piece set-in sleeves
 - short and long sleeve variations
- ◆ slightly shaped side seams that flare out slightly toward the bottom
- ◆ shaped bottom hem
- ◆ back panel to be cut with a tail

¹ This private specification has been compiled by National Private Specifications (Pty) Ltd. privatespecs@vodamail.co.za

Doc No	Item No	Date	Version	Page	No of pages
SAA 028	FL44 & FL45	September 2015	03.0	2	26

4. Illustrations

Illustrations are not to scale and are for guidance only.

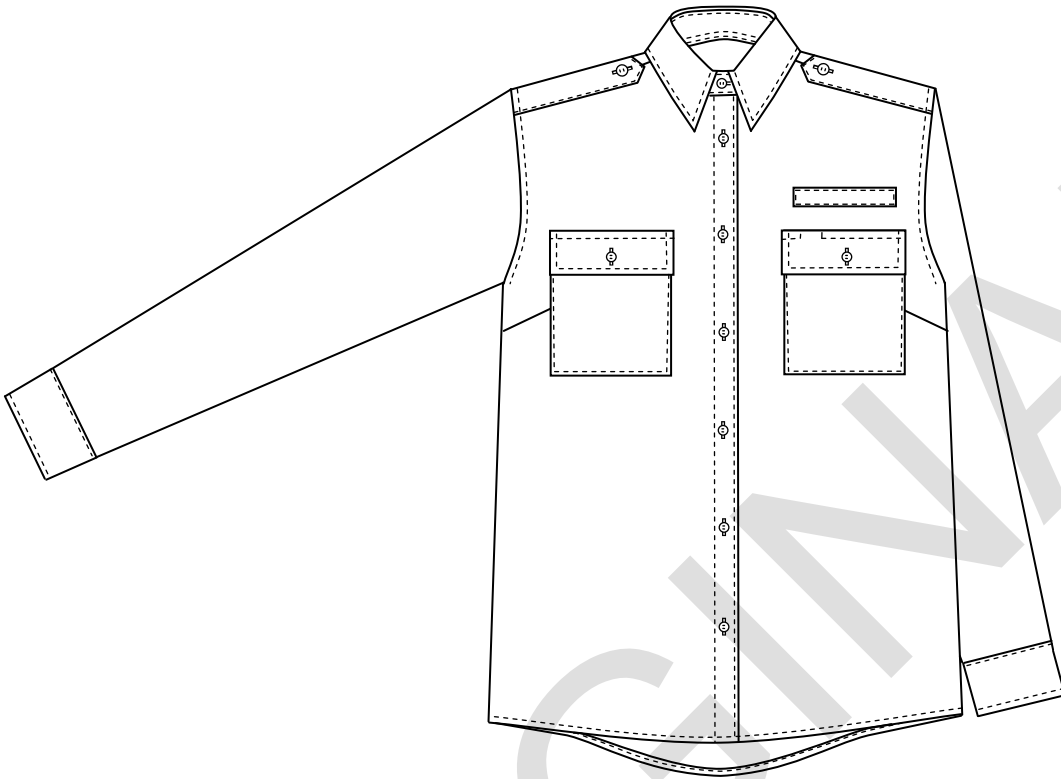

Figure 1 – Front, Long Sleeve

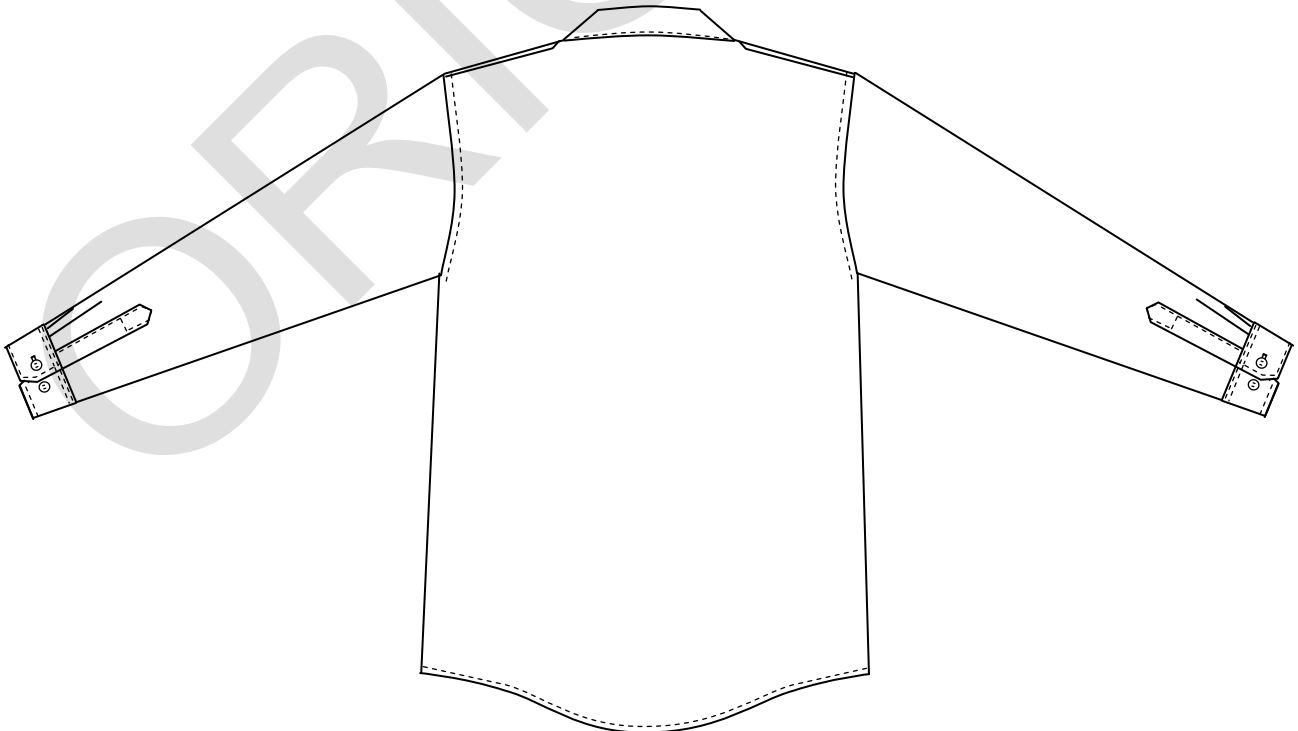

Figure 2 – Back, Long Sleeve

Doc No	Item No	Date	Version	Page	No of pages
SAA 028	FL44 & FL45	September 2015	03.0	3	26

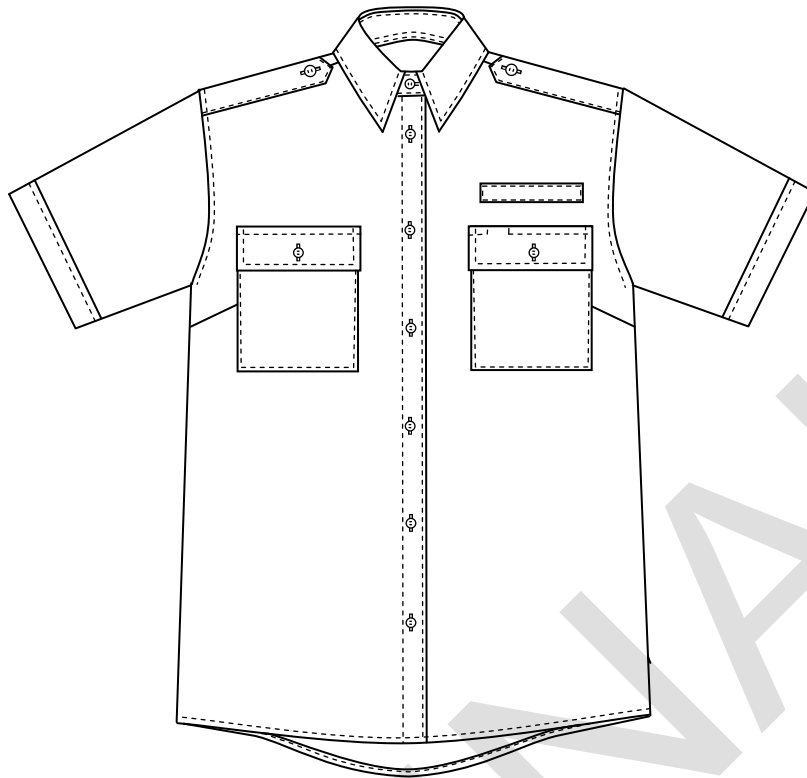

Figure 3 – Front, Short Sleeve

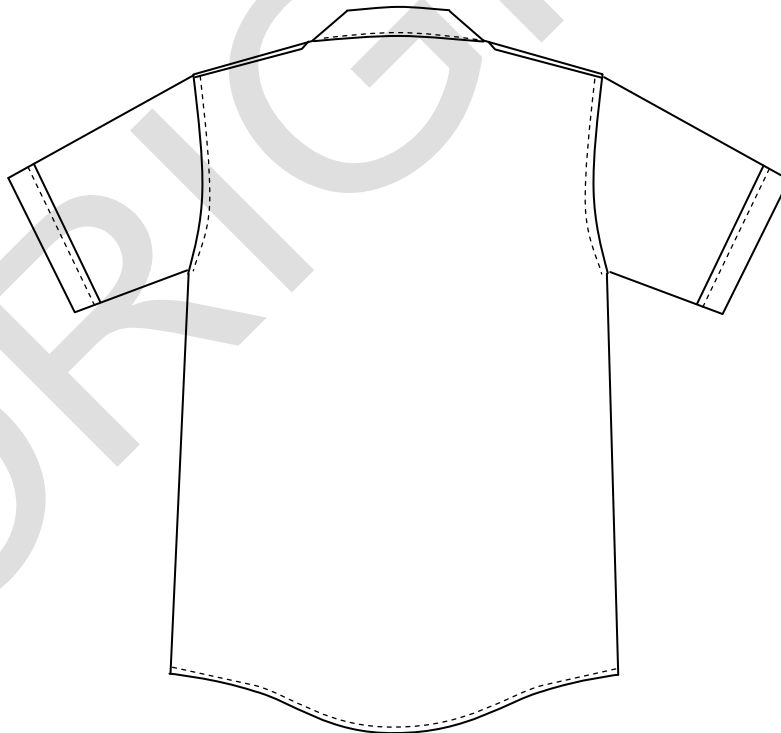

Figure 4 – Back, Short Sleeve

Doc No	Item No	Date	Version	Page	No of pages
SAA 028	FL44 & FL45	September 2015	03.0	4	26

5. Client Furnished Materials

No materials will be supplied by the South African Airways.

6. Component Materials

The following materials shall be supplied and used by the manufacturer. Trim charts shall also be submitted by the manufacturer (see Annex A).

NOTE: All components listed below shall be manufactured in the Republic of South Africa. In instances where the raw material and/or finished components are not available in the Republic of South Africa, the onus shall be on the bidder to apply for exemption certificates from DTI. Exemption certificates, where relevant, shall be submitted together with each bid.

6.1 Outer material

- ◆ to comply with the requirements as given in table 2
- ◆ to incorporate a moisture management system and silver finish to enhance comfort and hygiene
- ◆ colour to be an acceptable match, in terms of SANS 10076-1, "The assessment of defects in textile piece-goods and made-up articles Part 1: Defects in woven piece-goods (cellulosic and cellulosic blends)" to colour No. 638c-2014 "SAA White Shirting" of CKS 129 "Colours for textiles"

6.2 Interlining

- ◆ an acceptable fusible woven or non-woven interlining
- ◆ to comply with the requirements of CKS 627 "Fusible interlinings"
- ◆ interlining to be so bonded to the outer material that the bonded material:
 - has a uniform finish
 - is free from perforations, untreated areas and other imperfections (e.g. blisters and ripples)
- ◆ suitable for use in garments which are to be washed

The selection of interlining of appropriate mass per unit to be determined by consultation with the supplier of the interlining. The manufacturer will be held responsible for the performance of the interlining.

The purchaser reserves the right to change the type of interlining used during production, should the appearance of the finished garments be unsatisfactory.

6.3 Buttons

- ◆ four-hole
- ◆ clear plastics
- ◆ nominal diameter of 12 mm
- ◆ to comply with the requirements of SANS 1457 "Plastics buttons"
- ◆ of nominal thickness 2.5 mm (rim thickness)

Doc No	Item No	Date	Version	Page	No of pages
SAA 028	FL44 & FL45	September 2015	03.0	5	26

Table 2 - Outer material requirements

1	2	3
Property	Requirement	SANS standard unless otherwise indicated
Composition, %		1833-1 and 1833-11
Polyester	60 ± 5	
Cotton	40 ± 5	
Weave	Plain	Visual examination and physical analysis
Mass per area, g/m², min.	100	ISO 3801
Number of threads per centimetre		7211-2
Warp, min.	38	
Weft ^a	28	
Breaking strength, N, min.		13934-1
Warp	400	
Weft	600	
Tearing strength, N, min.		13937-2
Warp	12	
Weft	12	
Seam slippage, N, min.		ISO 13936-1
Warp	180	
Weft	180	
Resistance to pilling ^b, rating, min.	4 (slight)	6116
Resistance to abrasion ^c		6009
Rubs to endpoint, min.	20 000	
Dimensional changes on laundering @ 40°C, % max.		11167, Washing procedure F4/T4 Drying procedure A
Warp	3	
Weft	3	
Colour fastness to:		11166, Procedure A
Washing, rating, min.		
Change in colour	4	
Staining	4	
Perspiration, rating, min.		105-E04
Change in colour	4	
Staining	3-4	
Rubbing, rating, min.		105-X12
Dry	4	
Wet	3-4	
Light, rating, min.	5	105-B02

^a Subject to a tolerance of – 10 %.

^b After washing the test specimens in accordance with SANS 11108, Procedure B.

^c Under a pressure of 9 kPa.

Doc No	Item No	Date	Version	Page	No of pages
SAA 028	FL44 & FL45	September 2015	03.0	6	26

6.4 Threads

- ◆ to comply with relevant requirements of SANS 1362 "Sewing threads"
- ◆ colour to be an acceptable match to the colour of the outer material

Sewing and buttonhole thread:

- ◆ polyester-and-cotton core-spun **OR** staple polyester
- ◆ ticket No 120

Overlocking thread:

- ◆ crimp-textured polyester **OR** crimp-textured polyamide
- ◆ ticket No 140

7. Workmanship

The shirts shall be:

- ◆ cut and made with first-class workmanship throughout
- ◆ of uniform and acceptable make, colour and finish

Shall be free from:

- ◆ defects, that affect their appearance or may affect their serviceability (or both)
- ◆ marks
- ◆ spots
- ◆ stains, incurred in the making-up

Seams and stitches shall be:

- ◆ smooth and uniform
- ◆ free from twists, pleats and puckers
- ◆ sufficiently extensible to avoid seam cracking and undue shrinkage in use

Ends of sewing shall be:

- ◆ trimmed and loose threads removed
- ◆ back-tacked if unsecured

Doc No	Item No	Date	Version	Page	No of pages
SAA 028	FL44 & FL45	September 2015	03.0	7	26

8. Sizes and dimensions

Shirt measurements:

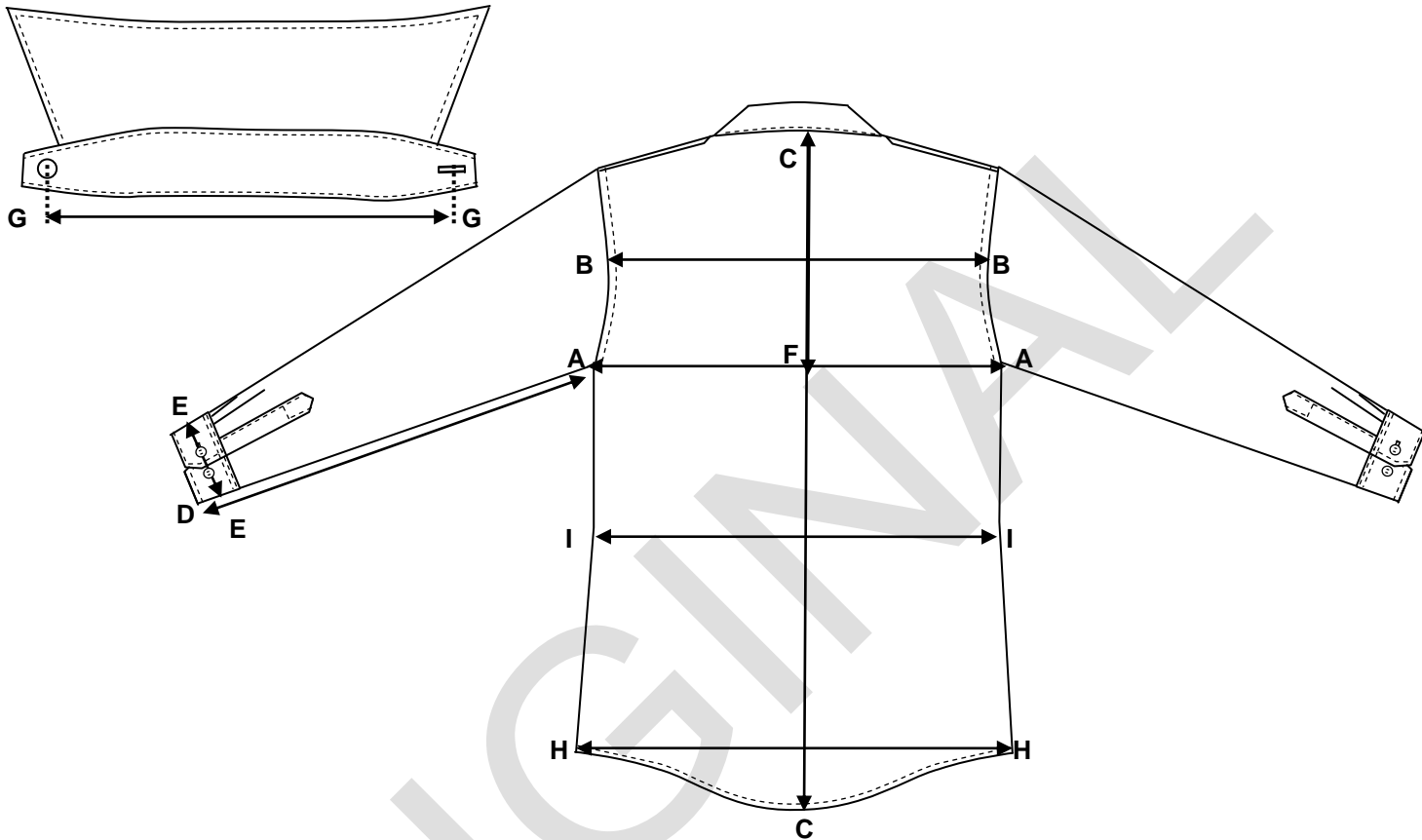

MEASURING POINT		DESCRIPTION
G – G	Collar length	Measure in a straight line from the centre of the button to the centre of the buttonhole.
A – A	Bust circumference	Measure at the base of the scye, with buttons fastened, garment spread completely flat, and multiply by two.
B – B	Back width	Measure across the width of the back at the midpoint of the scye from sleeve seam to sleeve seam.
C – C	Back length	Measure from the centre back neck seam to the bottom edge of the garment.
A – D	Underarm sleeve length	Measure from the base of the scye to the outer edge of the sleeve.
E – E	Cuff circumference	Measure the width at the centre of the cuff, buttoned to the first button and multiply by two.
C – F	Depth of scye	Measure from the centre back neck to the level of the base of the scye.
H – H	Bottom hem circumference	Measure in a straight line at the bottom outer edges of the hem, from the one side seam to the other, and multiply by two.
I – I	Waist circumference	Measure in a straight line across the garment at the natural waist position, narrowest part of the body, from one side seam to the other and multiply by two. NOTE: Measured at a point approximately 42 cm below the centre back neck point on size 38 and graded on the other sizes.

Doc No	Item No	Date	Version	Page	No of pages
SAA 028	FL44 & FL45	September 2015	03.0	8	26

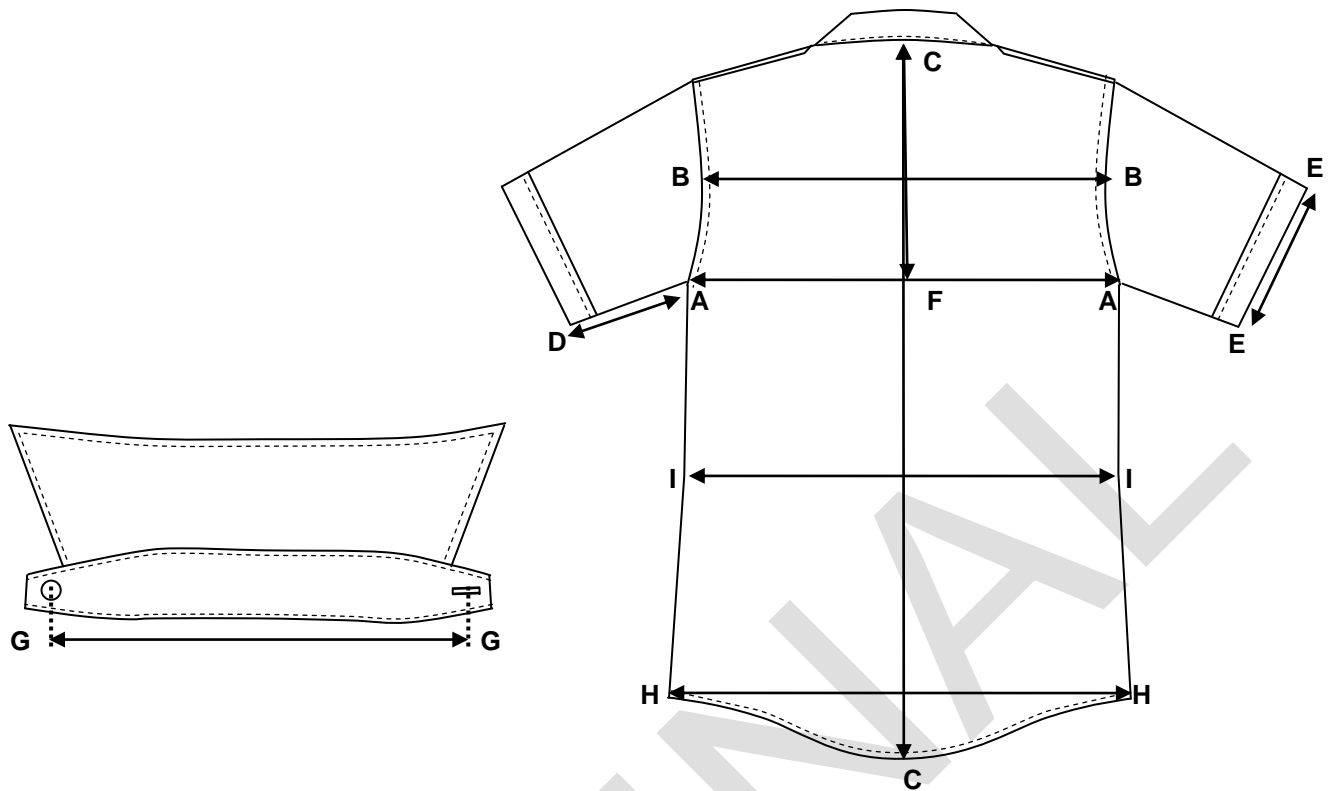

MEASURING POINT		DESCRIPTION
G – G	Collar length	Measure in a straight line from the centre of the button to the centre of the buttonhole.
A – A	Bust circumference	Measure at the base of the scye, with buttons fastened, garment spread completely flat, and multiply by two.
B – B	Back width	Measure across the width of the back at the midpoint of the scye from sleeve seam to sleeve seam.
C – C	Back length	Measure from the centre back neck seam to the bottom edge of the garment.
A – D	Underarm sleeve length	Measure from the base of the scye to the outer edge of the sleeve.
E – E	Cuff circumference	Measure the width at the outer edge of the cuff and multiply by two.
C – F	Depth of scye	Measure from the centre back neck to the level of the base of the scye.
H – H	Bottom hem circumference	Measure in a straight line at the bottom outer edges of the hem, from the one side seam to the other, and multiply by two.
I – I	Waist circumference	Measure in a straight line across the garment at the natural waist position, narrowest part of the body, from one side seam to the other and multiply by two. NOTE: Measured at a point approximately 42 cm below the centre back neck point on size 38 and graded on the other sizes.

Doc No	Item No	Date	Version	Page	No of pages
SAA 028	FL44 & FL45	September 2015	03.0	9	26

Table 3 – Size range

1	2	3	4	5	6	7	8	9	10		
Size designation ¹	Nominal finished garment measurements, cm										
	Collar Length	Bust Circumference	Back Width	Back Length	Sleeve Length		Cuff Circumference		Depth of Scye ²	Bottom hem circumference	Waist circumference
					long	short	long	short			
32	35.5	98	40	70.5	47	10	19.4	29	23	106.4	95
34	36.5	102	41	71	47	10	20	30	23.5	110.4	99.4
36	37.5	106.8	42	71.5	47	11	20	32	24	115.2	104.2
38	38.5	111.6	43	72	47.5	11	21	34	24.5	120	109
40	39.5	116.4	44	72.5	47.5	12	21	36	25	124.8	113.8
42	40.5	122.4	45.4	73	47.5	12	22	38	25.5	130.8	119.8
44	41.5	128.4	47	73.5	47.5	13	22	40	26	136.8	125.8
46	42.5	134.4	48.4	74	48	13	23	42	26.5	142.8	131.8
48	43.5	140.4	49.4	74.5	48	14	23	44	27	148.8	136.8
50	44.5	146.4	51	80	48	14	24	46	27.5	154.8	142.8
52	45.5	152.4	52.4	80.5	48	14	24	48	28	160.8	146.8
1 Based on the bust circumference of the intended wearer in inches. 2 Given for guidance											

Doc No	Item No	Date	Version	Page	No of pages
SAA 028	FL44 & FL45	September 2015	03.0	10	26

9. Make

Illustrations are not to scale and are for guidance only, and unless inconsistent with the text, all measurements are nominal.

9.1 Fronts

Fronts to:

- ◆ to fasten right over left
- ◆ each be fitted with a patch pocket
- ◆ each have a bust dart of appropriate length
- ◆ have shaped bottom hems with a 70 mm drop from the side seam to centre front

Right front to:

- ◆ incorporate a buttonhole stand
 - have a grown-on (cut-in-one with front) facing, forming the buttonhole stand
 - free edge to be turned in 30 mm, folded over 30 mm and stitched down 1 mm and 28 mm from the free edge
 - to extend from the gorge seam to the bottom hem
 - fitted with six buttonholes (excluding the buttonhole in the collar stand)
 - vertical shirt-type buttonholes
 - of such length as to neatly accommodate the buttons
 - neatly made and barred at the ends
 - centrally positioned in the buttonhole stand
 - topmost buttonhole (excluding buttonhole in collar stand) shall be positioned 55 mm below the buttonhole in the collar stand (centres)
 - remaining buttonholes to be equidistantly spaced at 8 – 10 cm intervals

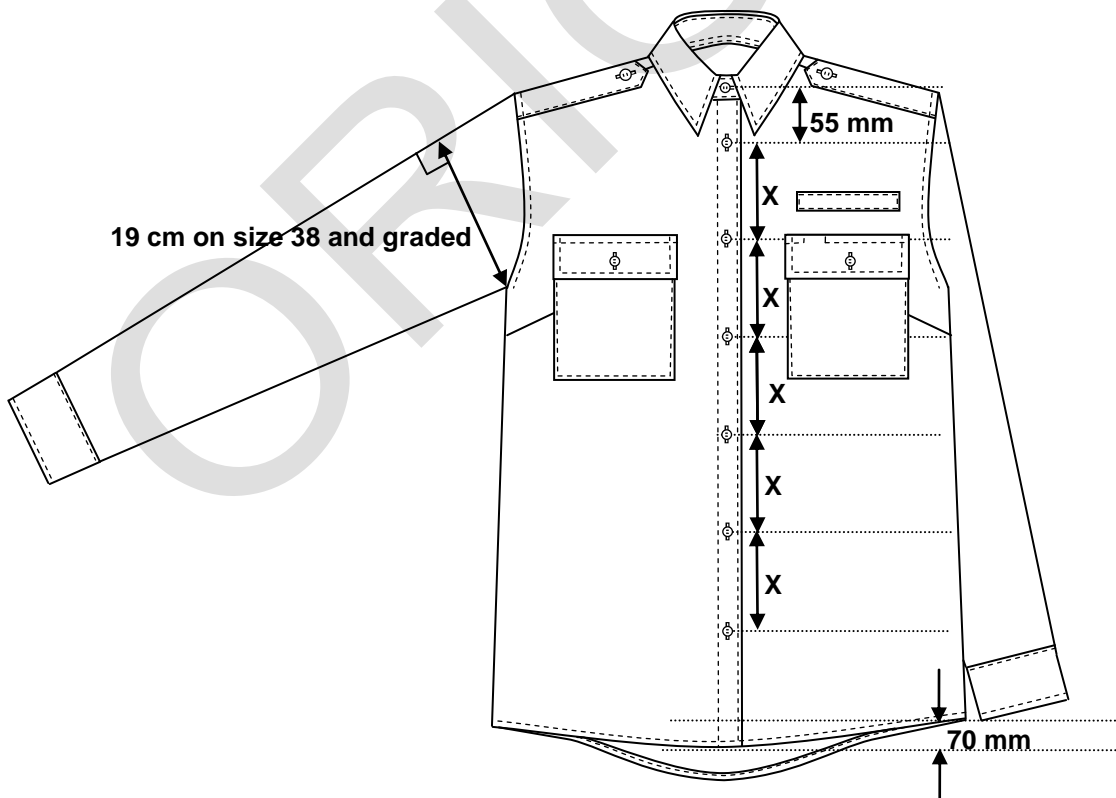

Figure 5 – Buttonhole positions and bicep measurement

Doc No	Item No	Date	Version	Page	No of pages
SAA 028	FL44 & FL45	September 2015	03.0	11	26

Left front to:

- ◆ be fitted with badge patch above the pocket
- ◆ have a grown-on (cut-in-one with front) facing, forming the buttonstand
 - free edge to be turned in approximately 27 mm, folded over approximately 27 mm and stitched down 25 mm from the free edge
 - to be fitted with six buttons (excluding button in collar stand)
 - in corresponding positions to the buttonholes in the buttonhole stand
 - to extend from the gorge seam to the bottom hem

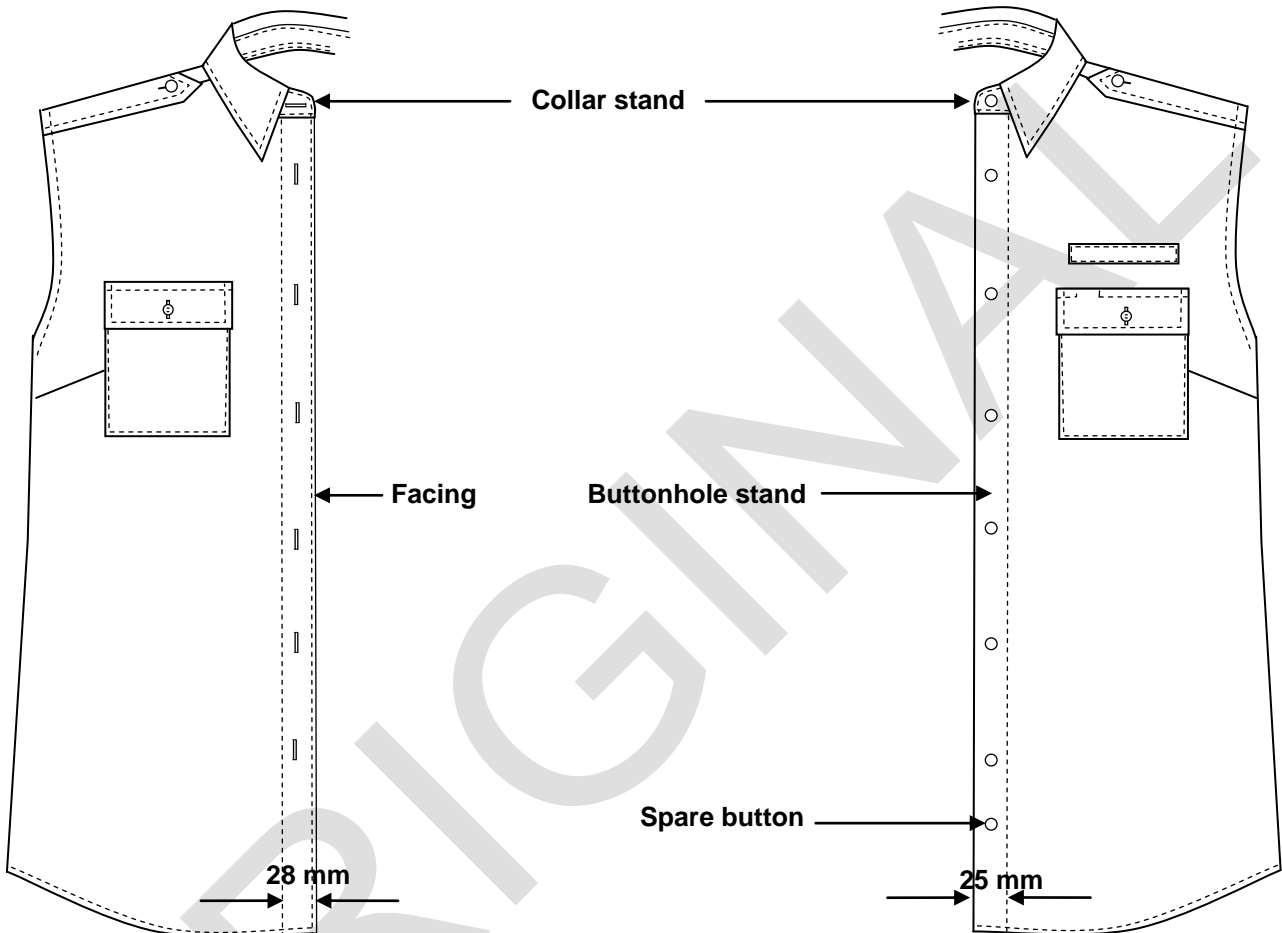

Figure 6 – Button and buttonhole stands

9.2 Collar

Collar to be:

- ◆ a two-piece shirt-type collar
- ◆ lined with outer material
- ◆ top collar to be interlined with interlining
- ◆ edge-stitched 6 mm along the leaf edge
- ◆ such that the points shall be of finished length 55 mm
- ◆ of finished depth 45 mm (fall)
- ◆ flat (i.e. free from curl) and smooth

Collar stand to:

- ◆ be of outer material
- ◆ be interlined with interlining (excluding the neck and centre front seam)

Doc No	Item No	Date	Version	Page	No of pages
SAA 028	FL44 & FL45	September 2015	03.0	12	26

- ◆ be lined with outer material
- ◆ be of finished depth 25 mm
- ◆ have rounded front corners
- ◆ be edge-stitched 2 mm along all edges
- ◆ be fitted with a button and buttonhole
 - positioned in such a way that there shall be a 5 mm gap between the upper edges of the collar when fastened
 - button to be positioned on the left front edge and in a corresponding position to that of the buttonhole
 - buttonhole to be positioned on the right front edge
 - horizontal
 - shirt type
 - neatly made and barred at each end
 - centrally positioned in the depth of the collar stand
 - of such length as to neatly accommodate the button

NOTE: The seam joining the stand to the fall shall be turned down into the stand and top-stitched. Sufficient hollow shall be given to the fall of the collar that when the shirt is fastened, there shall be enough length on the leaf edge to allow the collar to sit snugly around the neck.

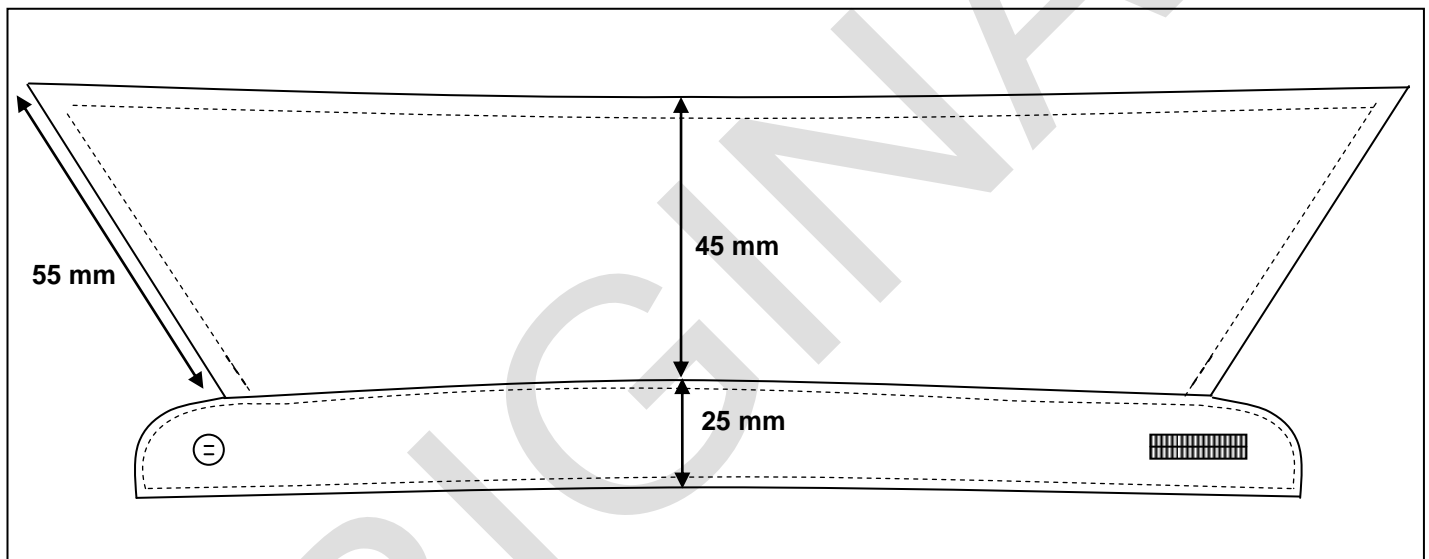

Figure 7 - Collar

9.3 Pockets

Pockets shall be:

- ◆ square patch pockets
- ◆ positioned with the sides parallel to the front edge
- ◆ to be positioned as given in table 4
- ◆ to be of finished width and depth 12 cm and 13 cm respectively
- ◆ fitted with a centrally positioned button in a corresponding position to the buttonhole on the flap

Pocket shall have:

- ◆ a pocket mouth hem of finished depth 25 mm (see fig. 8)
 - turned in 12 mm, then over 26 mm and stitched down
- ◆ box-tacked at the outer edges of the pocket mouth opening and properly secured at the ends
- ◆ to comply with the dimensions as given in figure 8
- ◆ 10 mm turned-in side and bottom raw edges
- ◆ edge-stitched 1 mm along the side and bottom edges
- ◆ a flap

Doc No	Item No	Date	Version	Page	No of pages
SAA 028	FL44 & FL45	September 2015	03.0	13	26

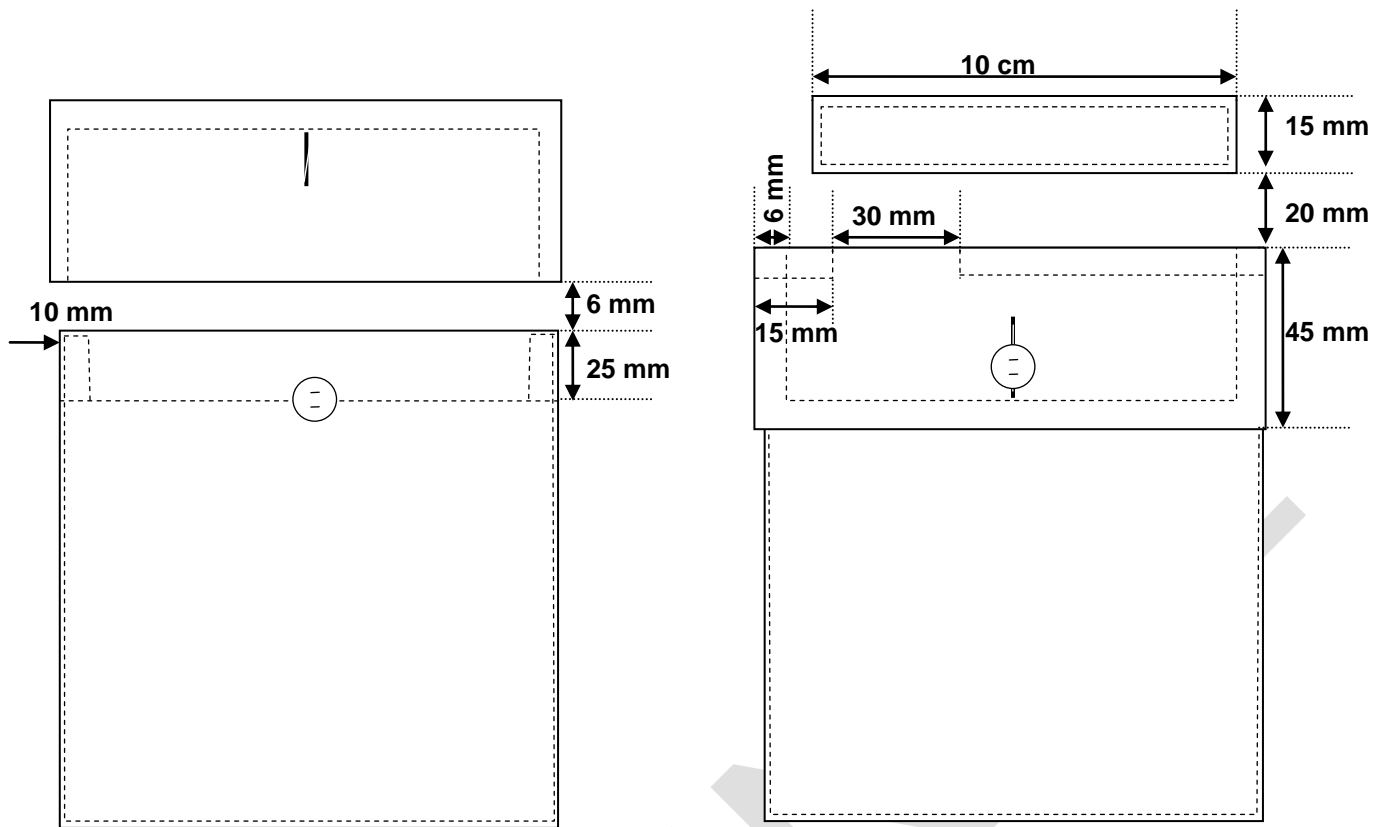

Figure 8 – Pocket and badge tab

Table 4 – Pocket positioning

1	2
Size designation	Distance from the front edge of the pocket to the front edge of the shirt
32 – 34	65 mm
36 – 42	70 mm
44 - 50	75 mm
52 - 54	80 mm

9.4 Pocket flap

Each pocket flap:

- ◆ be of double folded outer material
- ◆ interlined with interlining
- ◆ have square corners
- ◆ be of finished depth 45 mm
- ◆ to be 6 mm wider than the pocket (3 mm on either side of the pocket)
- ◆ centred above the pocket
- ◆ have a 6 mm top stitching along the bottom and side free edges
- ◆ positioned in such a way that there shall be a 6 mm gap between the pocket mouth opening and flap (see fig.8)
 - stitched down 5 mm, turned over and stitched down 6 mm from the turned over edge
- ◆ positioned 21 cm below the neck point on size 38 and graded for other sizes (see fig. 9)
- ◆ fitted with a buttonhole
 - vertical, shirt type
 - neatly made and barred at both ends

Doc No	Item No	Date	Version	Page	No of pages
SAA 028	FL44 & FL45	September 2015	03.0	14	26

- of such length to neatly accommodate the button
- positioned centrally 10 mm above the bottom edge of the flap

Left pocket flap to have:

- ◆ a pen slot
 - of finished width 30 mm
 - shall be positioned as given in figure 8
 - result in a through opening
 - properly secured at the ends
 - the pen slot opening shall be constructed in such a way that no raw edges are visible when the flap is lifted

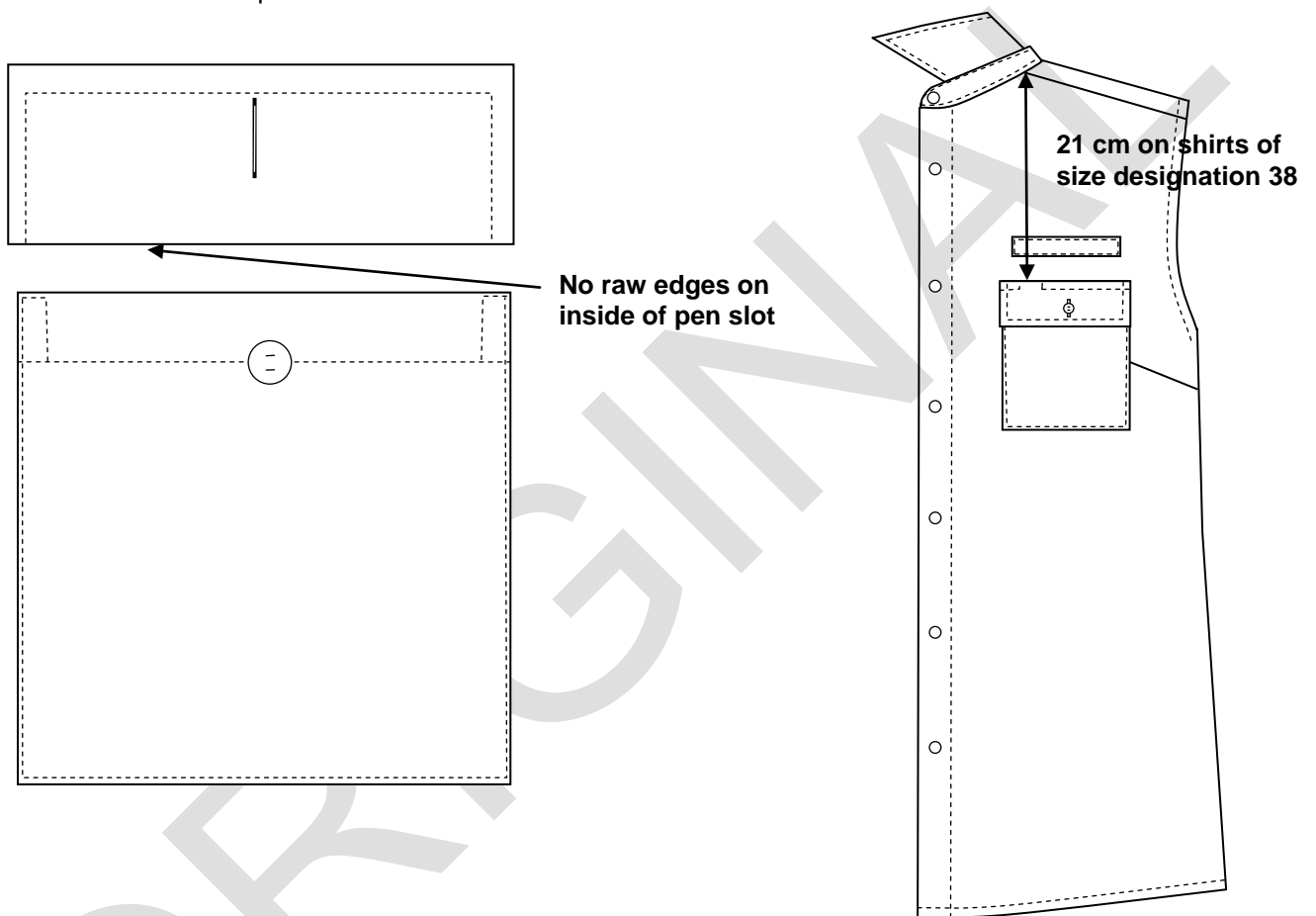

Figure 9 – Positioning of pocket flaps

9.5 Badge tab

- ◆ be of outer material
- ◆ be interlined with interlining
- ◆ be of finished length 10 cm and depth 15 mm
- ◆ have square corners
- ◆ be turned in along all the edges and stitched down 1 mm from the turned in edges
- ◆ be positioned centrally 20 mm above the pocket flap

9.6 Back

Back to:

- ◆ cut in such a way that it shall extend to 15 mm forward of the natural shoulder line
- ◆ cut in such a way that it shall have a tail as given in figure 10

Doc No	Item No	Date	Version	Page	No of pages
SAA 028	FL44 & FL45	September 2015	03.0	15	26

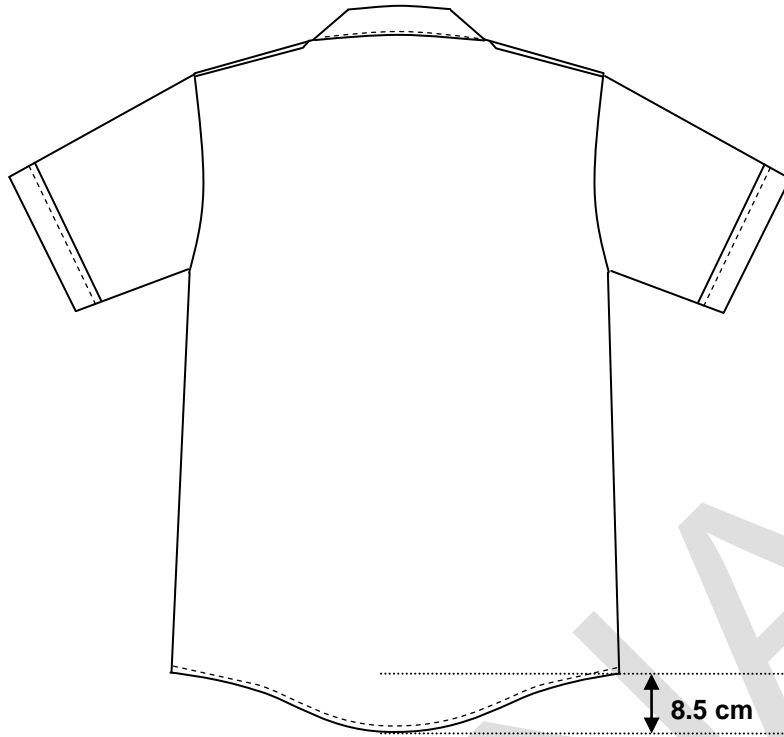

Figure 10 – Tail on back of shirt

9.7 Shoulder straps

Shoulder straps shall be:

- ◆ of outer material
- ◆ lined with outer material
- ◆ interlined with interlining (upper section only)
- ◆ mitred at the free end
- ◆ mitre to be of finished length 20 mm
- ◆ of finished width 50 mm at shoulder seam tapering to 40 mm at the base of the mitre
- ◆ of minimum length 13 cm (measured from the sleeve end to the base of the mitre)
- ◆ sewn in with the sleeve insertion seam
- ◆ positioned as given in figure 11
 - **shoulder seam positioned 15 mm forward of the natural shoulder line**
- ◆ top-stitched 6 mm around the free edges
- ◆ fitted with a buttonhole, centrally at the base of the mitre
 - shirt type and of such length as to neatly accommodate the buttons
 - neatly made and barred at both ends

Doc No	Item No	Date	Version	Page	No of pages
SAA 028	FL44 & FL45	September 2015	03.0	16	26

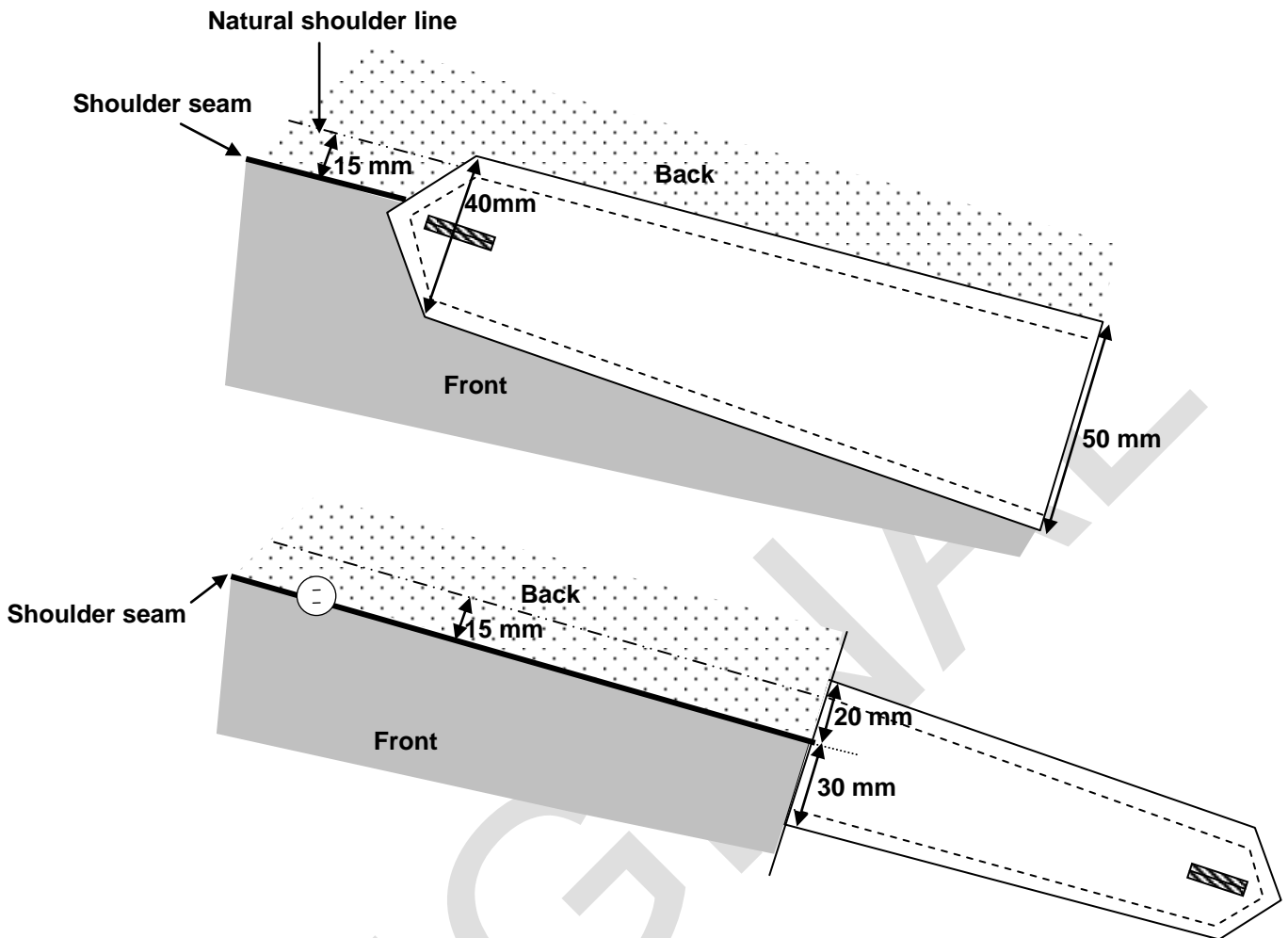

Figure 11 – Shoulder strap positioning

9.8 Sleeves

9.8.1 General

- ◆ one-piece
- ◆ set-in
- ◆ supplied as long and/or short sleeves as given in the order or contract
- ◆ sleeve insertion seam to be top-stitched 6 mm
- ◆ have a bicep circumference of 38 cm on size 38 when measured from the base of the scye, perpendicular to the overarm (see figure 5)

9.8.2 Long sleeves

The sleeves shall have:

- ◆ a single knife pleat
 - to be of finished depth 20 mm
 - positioned with the pleat 60 mm from the placket edge (see figure 12)
- ◆ have cuffs
 - a single cuff of outer material
 - lined with outer material
 - interlined with interlining
 - of finished depth 60 mm

Doc No	Item No	Date	Version	Page	No of pages
SAA 028	FL44 & FL45	September 2015	03.0	17	26

- have blunted corners of finished length 25 mm
 - shall fasten in the centre with a button and buttonhole
 - edge-stitched 6 mm along the side and bottom edges
 - edge-stitched 1 mm and 10 mm along the sleeve-to-cuff seam
 - fitted with a buttonhole
 - shirt type
 - neatly made and barred at the ends
 - of such length as to neatly accommodate the button
 - horizontal
 - positioned 10 mm from the free edge
 - fitted with two buttons
 - first button positioned 10 mm from cuff end (centres)
 - second buttonhole to be positioned 20 mm apart from the first (centres)
- ◆ a hind-arm opening
- finished off with a laid-on placket on the upper edge
 - placket to be of outer material
 - placket to be of finished width 25 mm
 - of finished length 13 cm (measured from the buttonhole on the cuff to the top edge)
 - underlapping edge shall be folded in, folded over and stitched down 3 mm from the folded edge

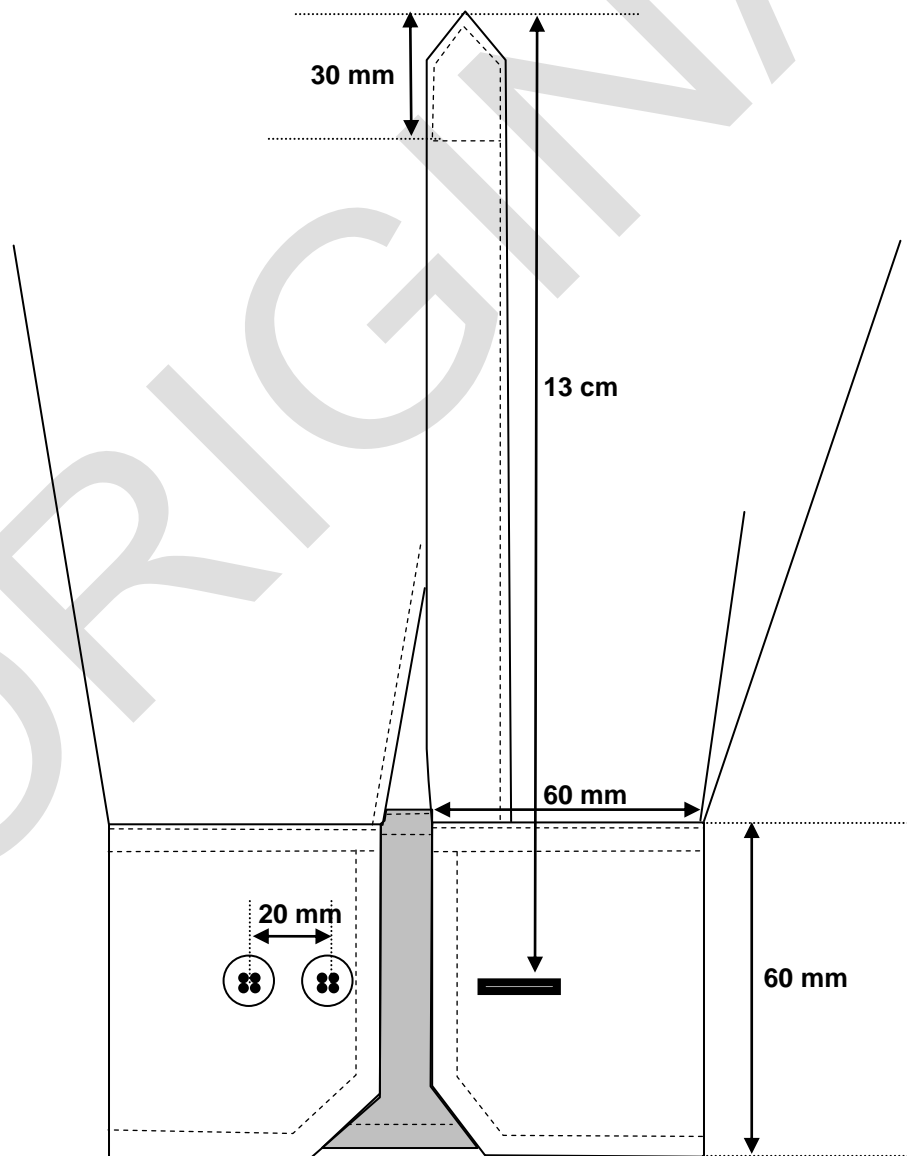

Figure 12 – Cuff and cuff opening

Doc No	Item No	Date	Version	Page	No of pages
SAA 028	FL44 & FL45	September 2015	03.0	18	26

9.8.3 Short sleeves

- ◆ such that it shall be mock cuffs of finished depth 30 mm
- ◆ the underarm seam at the outer edge of the cuff shall be stitched down to ensure that it lays flat

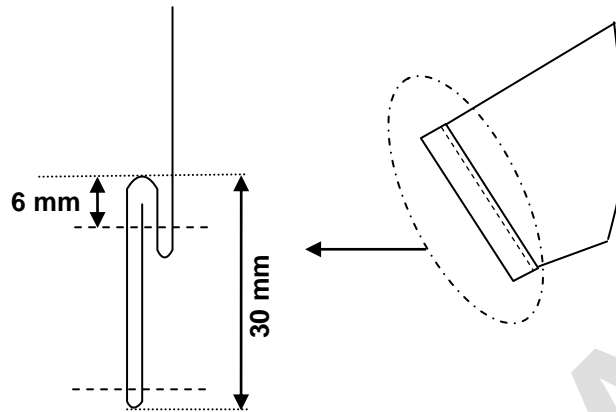

Figure 13 – Mock cuff construction

9.9 Spare buttons

- ◆ one spare button shall be sewn to the button stand below the lowest button (see figure 6)

9.10 Bottom hem

The bottom hem shall be:

- ◆ a rolled hem
- ◆ of finished width 5 mm

10. Stitches, Seams and Stitchings

10.1 Stitches

main seaming: safety stitch

other stitches: single needle lock stitch

10.2 Seams

Seams to be at least 10 mm wide (unless otherwise stated):

Side, shoulder and sleeve insertion seams: seam type SSa

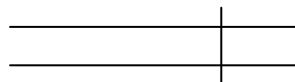

Superimpose two or more plies of material and seam with one row of stitches positioned at the specific distance(s) from the aligned edges.

Doc No	Item No	Date	Version	Page	No of pages
SAA 028	FL44 & FL45	September 2015	03.0	19	26

Leaf collar edge: Seam type SSe-2

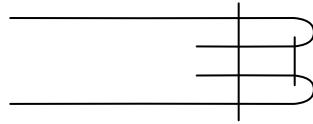

Form seam Type SSa-1, using two plies of material. Then turn back each ply at the seam and seam through the turned edges with the appropriate number of rows of stitches.

10.3 Stitchings

Exposed raw edges: stitching type EFd-1

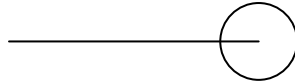

Stitch over the edge of a ply of material with one row of stitches.

Bottom hem and pocket mouth hem: stitching type EFb-1

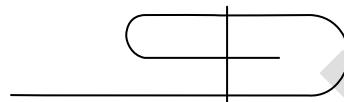

Turn in the specified width at the edge of a ply of material, fold back the turned edge, and stitch the turned-in and folded portion with the appropriate number of rows of stitches.

10.4 Number of stitches

The determination of sewing stitches per unit length will be done in accordance with SANS 5278 "Sewing stitches per unit length"

All seams: 42 ± 2 per 10 cm

top-stitching: 42 ± 2 per 10 cm

buttonholes: 12 ± 1 per 1 cm

button: 12 ± 1 per button

Doc No	Item No	Date	Version	Page	No of pages
SAA 028	FL44 & FL45	September 2015	03.0	20	26

11. Garment labels

NOTE: Tender samples shall be fitted with a printed label displaying the manufacturer's name or trade mark and size.

11.1 Label identification

Each garment shall be fitted with the labels as given in table 5:

Table 5 – Label identification

Type		Requirements
1.	a woven logo jacquard label	See 11.2
2.	a woven jacquard size label	See 11.3
3.	a garment specific printed woven fabric label*	See 11.4
4.	a care-label*	See 11.5
5.	a paperboard swing tag	See 11.6

*These two labels may be separate labels or a single loop label.

11.2 Jacquard logo label

Each label shall:

- ◆ be a woven jacquard label
- ◆ edges to be properly finished to prevent fraying
- ◆ information to be in legible and indelible block letters of height at least 3 mm
- ◆ permanently secured and sewn in with the collar seam at centre back
- ◆ be such that it shall outlast the garment
- ◆ include the following information:
 - the manufacturer's name or trade mark or both
 - the registered full-colour SAA logo at top of label (see figure below)



11.3 Jacquard size label

Each label shall:

- ◆ be a woven jacquard loop label
- ◆ edges to be properly finished to prevent fraying
- ◆ information to be in legible and indelible block letters of height at least 3 mm
- ◆ sewn together with the side edge of the jacquard logo label
- ◆ be such that it shall outlast the garment

Doc No	Item No	Date	Version	Page	No of pages
SAA 028	FL44 & FL45	September 2015	03.0	21	26

11.4 Printed garment labels

Each label shall:

- ◆ be white woven rayon label that is printed
- ◆ comply with SANS 1309 "Printed labels for textiles"
 - information to be in legible and indelible block letters of height at least 3 mm
- ◆ permanently secured and sewn to the back facing
- ◆ be such that they outlast the garments (including the markings)
- ◆ include the following information:
 - the item number
 - order number
 - the year and month of manufacture
 - the VAT no of the contractor
 - the country of origin, i.e. "Made in the RSA"

11.5 Printed care-labelling

Each label shall:

- ◆ be white woven rayon label that is printed
- ◆ comply with SANS 1309 "Printed labels for textiles"
 - information to be in legible and indelible block letters of height at least 3 mm
- ◆ permanently secured to the side seam
- ◆ be such that they outlast the garments (including the markings)
- ◆ to provide appropriate care instructions (in accordance with SANS 10011 "Care-labelling of textile piece-goods, textile articles and clothing") in words and symbols
- ◆ provide the fibre composition of the fabric in accordance with the requirements of SANS 10235 "Fibre content labelling of textiles and textile products"

11.6 Printed swing tags

Each swing tag shall:

- ◆ be a white cardboard printed label
- ◆ information to be in legible and indelible block letters of height at least 3 mm
- ◆ include the following information:
 - the size designation
 - the item number
 - the item description
 - the month and year of manufacture
 - the order number

12. Packaging and marking of packaging

NOTE: NO METAL PINS TO BE USED IN PACKAGING. PLASTIC CLIPS TO BE USED WHERE APPLICABLE.

12.1 Packing

12.1.1 The shirts shall be:

- ◆ delivered in a pressed and commercially dry condition
- ◆ so packed that they will not be damaged in transit or in storage
- ◆ individually placed on a hanger and packed in a plastics envelope of suitable size and shape
- ◆ unless otherwise specified in the order or contract, acceptably packed for transportation in bulk containers

Doc No	Item No	Date	Version	Page	No of pages
SAA 028	FL44 & FL45	September 2015	03.0	22	26

12.1.2 Shirts:

- ◆ of the same size designation and type to be packed together in a bulk container (unless quantities ordered are such that packing together of the same size and type only are not justified)
- ◆ of different size designations and types may also be packed together to accommodate the last part of an order or contract

12.2 Marking

12.2.1 Plastics envelopes

Each envelope to be clearly marked with the following information:

- ◆ the item number
- ◆ the item description
- ◆ size designation
- ◆ the order number
- ◆ month and year of manufacture

12.2.2 Bulk containers

Each bulk container shall have a label securely attached to the outside. This label shall be visible when the containers are stacked and shall provide the information in legible and indelible markings as follows:

- ◆ the manufacturer's name or trade mark or both
- ◆ the order number or contract number
- ◆ the item description
- ◆ the item number
- ◆ the size designation
- ◆ the quantity of the item
- ◆ the **month and year** of manufacture
- ◆ the order number
- ◆ the box number, e.g. "1 of 5"
- ◆ the total mass of the packed container
- ◆ the Inspection Certificate Number

12.3 Additional marking

When so required by the South African Airways, shirts, plastics envelopes or containers (or any combination of these) to bear information additional to that specified above.

Doc No	Item No	Date	Version	Page	No of pages
SAA 028	FL44 & FL45	September 2015	03.0	23	26

13. Normative References

The following documents contain provisions which, through reference in this text, constitute provisions of this specification. All documents are subject to revision and, since any reference to a document is deemed to be a reference to the latest edition of that document, parties to agreements based on this specification are encouraged to take steps to ensure the use of the most recent editions of the documents indicated below. Information on currently valid national, international and CKS documents may be obtained from SABS Standards Division *.

CKS 129, *Colours for textiles.*

CKS 627, *Fusible interlinings.*

ISO 3801, *Textiles – Woven fabrics – Determination of mass per unit length and mass per unit area.*

ISO 13936-1, *Textiles – Determination of the slippage resistance of yarns at a seam in woven fabrics – Part 1: Fixed seam opening method.*

SANS 79, *Textiles – Mass per unit area of conditioned fabrics.*

SANS 105-B02/ISO 105-B02, *Textiles – Tests for colour fastness – Part B02: Colour fastness to artificial light: Xenon arc fading lamp test.*

SANS 105-E04/ISO 105-E04, *Textiles – Tests for colour fastness – Part E04: Colour fastness to perspiration.*

SANS 105-X12/ISO 105-X12, *Textiles – Tests for colour fastness – Part X12: Colour fastness to rubbing.*

SANS 960, *Textiles – Dimensional stability during washing and drying procedures.*

SANS 1309, *Printed labels for textiles.*

SANS 1362, *Sewing threads.*

SANS 1457, *Plastics buttons.*

SANS 1833-1/ISO 1833-1, *Textiles – Quantitative chemical analysis – Part 1: General principles of testing.*

SANS 1833-11/ISO 1833-11, *Textiles – Quantitative chemical analysis – Part 11: Mixtures of cellulose and polyester fibres (method using sulphuric acid).*

SANS 5278, *Sewing stitches per unit length.*

SANS 6116, *Resistance of fabrics to pilling and fuzzing (Random tumble method).*

SANS 6009, *Abrasion resistance of textile fabrics (Martindale test).*

SANS 7211-2/ISO 7211-2, *Textiles – Woven fabrics – Construction – Methods of analysis – Part 2: Determination of number of threads per unit length.*

SANS 10011, *Care-labelling of textile piece-goods, textile articles and clothing.*

SANS 10076-1, *The assessment of defects in textile piece-goods and made-up articles – Part 1: Defects in woven piece-goods (cellulosic and cellulosic blends).*

SANS 10235, *Fibre - content labelling of textiles and textile products.*

SANS 10371, *Terms and definitions for clothing.*

SANS 11108, *Washing pretreatment of textile fabrics.*

SANS 11166, *Textiles – Colourfastness to domestic washing procedures.*

SANS 11167, *Textiles – Dimensional stability during domestic washing and drying procedures.*

* **South African Bureau of Standards: Tel. +27 (0) 12 4287911**

Doc No	Item No	Date	Version	Page	No of pages
SAA 028	FL44 & FL45	September 2015	03.0	24	26

SANS 13934-1/ISO 13934-1, *Textiles – Tensile properties of fabrics – Part 1: Determination of maximum force and elongation at maximum force using the strip method.*

SANS 13937-2/ISO 13937-2, *Textiles – Tear properties of fabrics – Part 2: Determination of tear force of trouser -shaped test specimens - Single Tear Method.*

ANNEX A

(Normative)

Special conditions of tender

A-1 GENERAL

A-1.1 Unless otherwise stated, the South African Bureau of Standards shall be the inspecting authority.

Any applications for deviations from drawings or the specification, or any laid down process, treatment or procedures as set out in this specification, must be made to the SA Airways and verified by the SABS². All applications must be submitted in writing.

A-1.2 Three pre-production sample long sleeved and three short sleeved shirts in different sizes, shall have been inspected, tested and approved by the inspecting authority before bulk production is commenced. Each one of these samples shall be accompanied by a trim chart containing a sample of each component material (as given in 6) and the relevant certificates. It shall be the duty of the manufacturer to give adequate notice to the inspecting authority of the availability of these samples.

A-1.3 The shirts shall be subject to inspection during the course of manufacture. The inspector shall, during normal working hours, be given all reasonable facilities for carrying out his duties and shall have the right of entry into the contractor's factory and the factory or works of any subcontractor where work on shirts supplied to this specification may be in progress

A-1.4 The contractor shall inspect the finished shirts for compliance with the specification before submitting them to the inspecting authority for final inspection.

A-1.5 Before acceptance, the shirts shall have been inspected and tested by the inspecting authority and found to comply with the requirements of the specification.

A-2 DOCUMENTATION

One container of each consignment shall be marked "DOCUMENTS" and in addition to the shirts, shall contain the following:

- a) The packaging slip or delivery note;
- b) where applicable the inspection certificate(s);
- c) a copy of the invoice containing the following information:
 - the order number
 - the financial authority number
 - a full description of the consignment, i.e. Item Number, quantity, etc

² **SABS Inspection Authority: (Tel) 012 4287371;**

Doc No	Item No	Date	Version	Page	No of pages
SAA 028	FL44 & FL45	September 2015	03.0	25	26

ANNEX B
(Normative)
CKS 129 Colours

Due to the fact that colours can change over a period of time, any colour standard which has been registered for a period of SEVEN YEARS or more shall be considered obsolete. These standards shall then be allocated an archived status (as opposed to current status) and re-registration shall be required.

A. The following scenarios require a submission of three metres of fabric from the successful tenderer:

1. A colour standard is archived.
2. First time registration is required (CKS 129 colour number does not exist).
3. Colour swatch stock at the SABS is no longer available.

B. Requirements for the submission of fabric as identified in A:

1. The colour shall be as agreed upon between the South African Airways and the successful tenderer.
2. The fabric shall be used to make new colour swatches which shall be the responsibility of the SABS.
3. The cost of the three metres of fabric shall be incorporated in the relevant tender submission.

HISTORY SHEET				
VERSION	DATE	AMENDMENTS/HISTORY	CHECKED	
			NAME	INIT.
1	March 2010	First release		
2	April 2014	Align spec with new samples and size chart New fabric Delete collar stiffener Complete redo Change item numbers		
3	September 2015	Add reference to bicep circumference on size 38 Add waist measurement and bottom hem circumference Amend back length, depth of scye and back width as per new sample		

Doc No	Item No	Date	Version	Page	No of pages
SAA 028	FL44 & FL45	September 2015	03.0	26	26