



prasa

PASSENGER RAIL AGENCY
OF SOUTH AFRICA

REQUEST FOR QUOTATION (RFQ)

RFQ NUMBER: KZN/PRASA/2025/11/02/Q

REQUEST FOR QUOTATION (RFQ) FOR THE APPOINTMENT OF A SERVICE PROVIDER FOR THE SUPPLY AND DELIVERY OF CROSS-SECTIONAL AREA OF 161mm² LENGTH OF 1830M HARD DRAWN GROOVED COPPER-MAGNESIUM CONTACT WIRE FOR ELECTRICAL DEPARTMENT IN KZN REGION

RFQ, KZN/PRASA/2025/11/01-Q,

KZN/PRASA/2025/11/02-Q,

KZN/PRASA/2025/11/03-Q,

KZN/PRASA/2025/11/04-Q

are advertised simultaneously, they will be evaluated and adjudicated simultaneously as a series. To manage performance risk and financial risk by not overloading one service provider with work and financial burden, no, one service provider will be awarded more than one contract from this series of RFQ contracts. If a bidder is responsive in more than one RFQ, Prasa will award following the sequence of the RFQ's by considering the first then the second, etc. the other subsequent RFQ's where they are also responsive will be awarded to the second responsive bidder. Should the second responsive bidder have already been recommended on one other RFQ of this series, then the next responsive bidder will be considered.

SECTION 1: SBD1

PART A INVITATION TO BID

YOU ARE HEREBY INVITED TO BID FOR REQUIREMENTS OF PASSENGER RAIL AGENCY (PRASA)					
BID NUMBER:	KZN/PRASA/2025/11/02/Q	CLOSING DATE:	25 November 2025	CLOSING TIME:	12H00
DESCRIPTION	APPOINTMENT OF A SERVICE PROVIDER FOR THE SUPPLY AND DELIVERY OF CROSS-SECTIONAL AREA OF 161mm ² LENGTH OF 1830M HARD DRAWN GROOVED COPPER-MAGNESIUM CONTACT WIRE FOR ELECTRICAL DEPARTMENT IN KZN REGION				
BID RESPONSE DOCUMENTS SHALL BE ADDRESSED AS FOLLOWS:					
BID RESPONSE DOCUMENTS MAY BE DEPOSITED IN THE BID BOX NO.04 SITUATED AT (<i>STREET ADDRESS</i>): PRASA OFFICES 65 MASABALALA YENGWA AVENUE GREYVILLE 4001 DURBAN STATION					
BIDDING PROCEDURE ENQUIRIES MAY BE DIRECTED TO					
CONTACT PERSON	Sihesenkosi Ngubane				
TELEPHONE NUMBER	031 813 0139				
E-MAIL ADDRESS	Sihesenkosi.Ngubane@prasa.com				
SUPPLIER INFORMATION					
NAME OF BIDDER					
POSTAL ADDRESS					
STREET ADDRESS					
TELEPHONE NUMBER	CODE		NUMBER		
CELLPHONE NUMBER					
FACSIMILE NUMBER	CODE		NUMBER		
E-MAIL ADDRESS					
VAT REGISTRATION NUMBER					
SUPPLIER COMPLIANCE STATUS	TAX COMPLIANCE SYSTEM PIN:		OR	CENTRAL SUPPLIER DATABASE No:	MAAA.....
2.1 ARE YOU THE ACCREDITED REPRESENTATIVE IN SOUTH AFRICA FOR THE GOODS /SERVICES /WORKS OFFERED?	<input type="checkbox"/> Yes <input type="checkbox"/> No [IF YES ENCLOSE PROOF]		2.2 ARE YOU A FOREIGN BASED SUPPLIER FOR THE GOODS /SERVICES /WORKS OFFERED?	<input type="checkbox"/> Yes <input type="checkbox"/> No [IF YES, ANSWER THE QUESTIONNAIRE BELOW]	
QUESTIONNAIRE TO BIDDING FOREIGN SUPPLIERS					
IS THE ENTITY A RESIDENT OF THE REPUBLIC OF SOUTH AFRICA (RSA)?			<input type="checkbox"/> YES <input type="checkbox"/> NO		
DOES THE ENTITY HAVE A BRANCH IN THE RSA?			<input type="checkbox"/> YES <input type="checkbox"/> NO		
DOES THE ENTITY HAVE A PERMANENT ESTABLISHMENT IN THE RSA?			<input type="checkbox"/> YES <input type="checkbox"/> NO		
DOES THE ENTITY HAVE ANY SOURCE OF INCOME IN THE RSA?			<input type="checkbox"/> YES <input type="checkbox"/> NO		

IS THE ENTITY LIABLE IN THE RSA FOR ANY FORM OF TAXATION?

YES NO

IF THE ANSWER IS “NO” TO ALL OF THE ABOVE, THEN IT IS NOT A REQUIREMENT TO REGISTER FOR A TAX COMPLIANCE STATUS SYSTEM PIN CODE FROM THE SOUTH AFRICAN REVENUE SERVICE (SARS) AND IF NOT REGISTER AS PER 2.3 BELOW.

PART B: TERMS AND CONDITIONS FOR BIDDING

1. BID SUBMISSION:

- 1.1. BIDS MUST BE DELIVERED BY THE STIPULATED TIME TO THE CORRECT ADDRESS. LATE BIDS WILL NOT BE ACCEPTED FOR CONSIDERATION.
- 1.2. **ALL BIDS MUST BE SUBMITTED ON THE OFFICIAL FORMS PROVIDED– (NOT TO BE RE-TYPED) OR IN THE MANNER**
- 1.3. **PRESCRIBED IN THE BID DOCUMENT.**
- 1.4. THIS BID IS SUBJECT TO THE PREFERENTIAL PROCUREMENT POLICY FRAMEWORK ACT, 2000 AND THE PREFERENTIAL PROCUREMENT REGULATIONS, 2022, THE GENERAL CONDITIONS OF CONTRACT (GCC) AND, IF APPLICABLE, ANY OTHER SPECIAL CONDITIONS OF CONTRACT.

2. TAX COMPLIANCE REQUIREMENTS

- 2.1 BIDDERS MUST ENSURE COMPLIANCE WITH THEIR TAX OBLIGATIONS.
- 2.2 BIDDERS ARE REQUIRED TO SUBMIT THEIR UNIQUE PERSONAL IDENTIFICATION NUMBER (PIN) ISSUED BY SARS TO ENABLE PRASA TO VERIFY THE TAXPAYER'S PROFILE AND TAX STATUS.
- 2.3 APPLICATION FOR TAX COMPLIANCE STATUS (TCS) PIN MAY BE MADE VIA E-FILING THROUGH THE SARS WEBSITE WWW.SARS.GOV.ZA.
- 2.4 BIDDERS MAY ALSO SUBMIT A PRINTED TCS CERTIFICATE TOGETHER WITH THE BID.
- 2.5 IN BIDS WHERE CONSORTIA / JOINT VENTURES / SUB-CONTRACTORS ARE INVOLVED, EACH PARTY MUST SUBMIT A SEPARATE TCS CERTIFICATE / PIN / CSD NUMBER.
- 2.6 WHERE NO TCS PIN IS AVAILABLE BUT THE BIDDER IS REGISTERED ON THE CENTRAL SUPPLIER DATABASE (CSD), A CSD NUMBER MUST BE PROVIDED.
- 2.7 NO BIDS WILL BE CONSIDERED FROM PERSONS IN THE SERVICE OF THE STATE, COMPANIES WITH DIRECTORS WHO ARE PERSONS IN THE SERVICE OF THE STATE, OR CLOSE CORPORATIONS WITH MEMBERS PERSONS IN THE SERVICE OF THE STATE.

NB: FAILURE TO PROVIDE / OR COMPLY WITH ANY OF THE ABOVE PARTICULARS MAY RENDER THE BID INVALID.

SIGNATURE OF BIDDER:

CAPACITY UNDER WHICH THIS BID IS SIGNED:

(Proof of authority must be submitted e.g. company resolution)

DATE:

NB:

- **Quotation(s) must be addressed to PRASA before the closing date and time shown above.**
- **PRASA General Conditions of Purchase shall apply.**

SECTION 2

NOTICE TO BIDDERS

1. RESPONSES TO RFQ

Responses to this RFQ [Quotations] must not include documents or reference relating to any other quotation or proposal. Any additional conditions must be embodied in an accompanying letter.

Proposals must reach PRASA before the closing hour on the date shown on SBD1 above and must be enclosed in a sealed envelope.

2 COMMUNICATION

Bidder/s are warned that a response will be liable for disqualification should any attempt be made either directly or indirectly to canvass any SCM Officer(s) or PRASA employee in respect of this RFQ between the closing date and the date of the award of the business.

3 BIDDERS COMPLAINTS PROCESS

3.1 Bidders are advised utilize this email address (Complaints@prasa.com) for lodging of complaints to PRASA in relation to this bid process. The following minimum information about the bidder must be included in the complaint:

- 3.1.1 Bid/Tender Description;
- 3.1.2 Bid/Tender Reference Number;
- 3.1.3 Closing date of Bid/Tender;
- 3.1.4 Supplier Name;
- 3.1.5 Supplier Contact details; and
- 3.1.6 The detailed compliant.

4 LEGAL COMPLIANCE

The successful Bidder shall be in full and complete compliance with any and all applicable national and local laws and regulations.

5 CHANGES TO QUOTATIONS

Changes by the Bidder to its submission will not be considered after the closing date and time.

6 PRICING

All prices must be quoted in South African Rand on a fixed price basis, including all applicable taxes.

7 BINDING OFFER

Any Quotation furnished pursuant to this RFQ shall be deemed to be an offer. Any exceptions to this statement must be clearly and specifically indicated.

8 DISCLAIMERS

PRASA is not committed to any course of action as a result of its issuance of this RFQ and/or its receipt of a Quotation in response to it. Please note that PRASA reserves the right to:

- Modify the RFQ's goods / service(s)/works and request Bidders to re-bid on any changes;
- Reject any Quotation which does not conform to instructions and specifications which are detailed herein; and
- Reject Quotations submitted after the stated submission deadline or at the incorrect venue.

Should a contract be awarded on the strength of information furnished by the bidder, which after conclusion of the contract, is proved to have been incorrect, PRASA reserves the right to cancel the contract.

PRASA reserves the right to award business to the highest scoring bidder/s unless objective criteria justify the award to another bidder.

Should the preferred bidder fail to sign or commence with the contract within a reasonable period after being requested to do so, PRASA reserves the right to award the business to the next highest ranked bidder provided that he/she/it is still prepared to provide the required goods at the quoted price.

9 LEGAL REVIEW

Proposed contractual terms and conditions submitted by a bidder will be subjected to review and acceptance or rejection by PRASA’s Legal Counsel, prior to consideration for an award of business.

10 NATIONAL TREASURY’S CENTRAL SUPPLIER DATABASE

Bidders are required to self-register on National Treasury’s Central Supplier Database (CSD) which has been established to centrally administer supplier information for all organs of state and facilitate the verification of certain key supplier information. PRASA is required to ensure that price quotations are invited and accepted from prospective bidders listed on the CSD. Business may not be awarded to a bidder who has failed to register on the CSD. Only foreign suppliers with no local registered entity need not register on the CSD. The CSD can be accessed at <https://secure.csd.gov.za/>.

11 PROTECTION OF PERSONAL DATA

In responding to this bid, PRASA acknowledges that it may obtain and have access to personal data of the Bidders. PRASA agrees that it shall only process the information disclosed by Bidders in their response to this bid for the purpose of evaluating and subsequent award of business and in accordance with any applicable law.

Furthermore, PRASA will not otherwise modify, amend or alter any personal data submitted by Bidders or disclose or permit the disclosure of any personal data to any Third Party without the prior written consent from the Bidders. Similarly, PRASA requires Bidders to process any personal information disclosed by PRASA in the bidding process in the same manner.

12 EVALUATION METHODOLOGY

PRASA will utilise the following criteria in choosing a Supplier/Service Provider:

Evaluation CRITERIA	WEIGHTING
Stage 1 – Compliance	
Stage 1A	Mandatory Requirements
Stage 1B	Other Mandatory Requirements
Stage 2	
Technical/Functional Requirements	N/A
Stage 3	
Price	80
Specific Goals	20
TOTAL	100

13 ADMINISTRATIVE RESPONSIVENESS

The test for administrative responsiveness will include completeness of response and whether all returnable and/or required documents, certificates; verify completeness of warranties and other bid requirements and formalities have been complied with. Incomplete Bids will be disqualified.

14 VALIDITY PERIOD

14.1 PRASA requires a validity period of **60 Working Days** from the closing date.

14.2 Bidders are to note that they may be requested to extend the validity period of their response, on the same terms and conditions, if the internal processes are not finalized within the validity period. However, once the delegated authority has approved the process the validity of the successful bidder(s)' bid will be deemed to remain valid until finalization of the of award.).

15 PUBLICATION OF INFORMATION ON THE NATIONAL TREASURY E-TENDER PORTAL

Bidders are to note that, bid awards, amendments and cancellations will be published on the e-tender portal and or media used to advertise the bid. For the award of business, PRASA is required to publish the prices and preferences claimed of the successful and unsuccessful Bidders *inter alia* on the National Treasury e-Tender Publication Portal, (www.etenders.gov.za), on CIDB website for construction related RFQ's. (*Where applicable*).

16 RETURNABLE DOCUMENTS

Returnable Documents means all the documents, Sections and Annexures, as listed in the tables below. There are three types of returnable documents as indicated below and Bidders are urged to ensure that these documents are returned with the quotation based on the consequences of non-submission as indicated below:

16.1. Mandatory Returnable Documents

Failure to provide Mandatory Returnable Documents at the Closing Date and time of this RFQ will result in a Bidder's disqualification. Bidders are therefore urged to ensure that all documents are returned with their Quotations.

SECTION 3

1 Evaluation CRITERIA:

Stage 1A – Mandatory Requirements

If you do not submit the following mandatory documents/requirements, your bid will be automatically disqualified.

Only bidders who comply with stage 1A will be evaluated further.

No.	Description of requirement	
a)	The supplier must submit in writing (on a signed company letterhead) with this RFQ, acknowledging that: <ul style="list-style-type: none"> • The technical specifications of the products listed in the RFQ document will be met. • Non-conformances will be closed within 10 days 	

Stage 1B –Other Mandatory Requirements

If you do not submit the following mandatory documents/requirements, PRASA may request the bidder to submit the information within three (3) working days. Should this information not be provided, your bid proposal will be disqualified.

Only bidders who comply with stage 1B will be evaluated further.

No.	Description of requirement	
a)	Completion of ALL RFP documentation (includes ALL declarations)	
b)	Bidders to fill and sign the closing/submission register on submission of RFQ documents, failure to comply will result in a disqualification from the RFQ process	
c)	Joint Venture, Consortium Agreement or Partnering Agreement/ Subcontract Agreement signed by all parties. The agreement should indicate the leading bidder where applicable. (Delete if not applicable)	
d)	Valid SARS Pin	
e)	CSD supplier registration number	

3.Stage 3- Price and Specific Goals

The following formula, shall be used to allocate scores to the interested bidders :

The maximum points for this tender are allocated as follows:

DETAILS	POINTS
PRICE	80
SPECIFIC GOALS	20
TOTAL POINTS FOR PRICE AND SPECIFIC GOALS	100

FORMULAE FOR PROCUREMENT OF GOODS AND SERVICES

POINTS AWARDED FOR PRICE

THE 80/20 PREFERENCE POINT SYSTEMS

A maximum of 80 points is allocated for price on the following basis:

80/20

$$PS = 80 \left(1 - \frac{Pt - Pmin}{Pmin} \right)$$

Where

Ps = Points scored for price of tender under consideration

Pt = Price of tender under consideration

Pmin = Price of lowest acceptable tender

POINTS AWARDED FOR SPECIFIC GOALS

- 3.1. In terms of Regulation 4(2); 5(2); 6(2) and 7(2) of the Preferential Procurement Regulations, preference points must be awarded for specific goals stated in the tender. For the purposes of this tender the tenderer will be allocated points based on the goals stated in table 1 below as may be supported by proof/ documentation stated in the conditions of this tender:

Table 1: Specific goals for the tender and points claimed are indicated per the table below.

Note to tenderers: The tenderer must indicate how they claim points for each preference point system.)

The specific goals allocated points in terms of this tender	Number of points allocated (80/20 system) (To be completed by the organ of state)	Number of points claimed (80/20 system) (To be completed by the tenderer)
Entities with a B-BBEE contributor status of at least level 2 - B-BBEE Certificate/Affidavit	10	
51% Black Owned - CIPC Documents/B-BBEE Certificate/Affidavit	10	
Total	20	

APPOINTMENTS OTHER THAN THE SUCCESSFUL BIDDER

- 1.1** PRASA may appoint a bidder other than the successful bidder under the following instances:
- (i) When a successful bidder, after having been informed of the acceptance of its Bid, fails to sign a contract within a prescribe period of time e.g. 14 (fourteen) days after being called upon to do so;
 - (ii) When a successful bidder has failed to provide the necessary security, bonds or guarantees within the time required to do so by PRASA;
 - (iii) When a successful bidder fails to meet a condition precedent for the award of business (e.g. to obtain the necessary funding); and
 - (iv) When final contract negotiations with a preferred bidder fails and a contract is not agreed upon.
- 1.2** PRASA will only award a bid to a bidder other than the highest scoring bidder provided that such bid is still within the bid validity period.
- 1.3** Only if the second ranked bidder is also unable/unwilling, PRASA may proceed to the third ranked bidder.

SECTION 5

PRICING AND DELIVERY SCHEDULE

Bidders are required to complete the attached Pricing Schedule **Annexure:**

- 1 Prices must be quoted in South African Rand, inclusive of all applicable taxes.
- 2 Price offer is firm and clearly indicate the basis thereof.
- 3 Pricing Bill of Quantity is completed in line with schedule if applicable (delete if not applicable).
- 4 Cost breakdown must be indicated.
- 5 Price escalation basis and formula must be indicated.
- 6 To facilitate like-for like comparison bidders must submit pricing strictly in accordance with this price schedule and not utilise a different format. Deviation from this pricing schedule could result in a bid being declared non-responsive.
- 7 Please note that should you have offered a discounted price(s), PRASA will only consider such price discount(s) in the final evaluation stage on an unconditional basis.
- 8 Bidders are to note that if price offered by the highest scoring bidder is not market related, PRASA may not award the contract to the Bidder. PRASA may:
 - 9 Negotiate a market-related price with the Bidder scoring the highest points;
 - 10 If that Bidder does not agree to a market-related price, negotiate a market-related price with the Bidder scoring the second highest points;
 - 11 If the Bidder scoring the second highest points does not agree to a market-related price, negotiate a market-related price with the Bidder scoring the third highest points;
 - 12 If a market-related price is not agreed with the Bidder scoring the third highest points, PRASA must cancel the RFQ.

I / We _____ (Insert Name of Bidding Entity) of

_____ code _____

(Full address) conducting business under the style or title of: _____ represented

by: _____ in my capacity as:

_____ being duly authorised, hereby offer to undertake and complete the above-mentioned work/services at the prices quoted in the bills of quantities / schedule of quantities or, where these do not form part of the contract, at a lumpsum, of

R _____ (amount in numbers);

_____ (amount in words) Incl. VAT.

DELIVERY PERIOD: Suppliers are requested to offer their earliest delivery period possible.

Delivery will be effected within working days from date of order. (To be completed by Service provider)

SECTION 5

PRASA GENERAL CONDITIONS OF PURCHASE

General

PRASA and the Supplier enter into an order/contract on these conditions to supply the items (goods/services/works) as described in the order/contract.

Conditions

These conditions form the basis of the contract between PRASA and the Supplier. Notwithstanding anything to the contrary in any document issued or sent by the Supplier, these conditions apply except as expressly agreed in writing by PRASA.

No servant or agent of PRASA has authority to vary these conditions orally. These general conditions of purchase are subject to such further special conditions as may be prescribed in writing by PRASA in the order/contract.

Price and payment

The price or rates for the items stated in the order/contract may include an amount for price adjustment, which is calculated in accordance with the formula stated in the order/contract.

The Supplier may be paid in one currency other than South African Rand. Only one exchange rate is used to convert from this currency to South African Rand. Payment to the Supplier in this currency other than South African Rand, does not exceed the amounts stated in the order/contract. PRASA pays for the item within 30 days of receipt of the Suppliers correct tax invoice.

Delivery and documents

The Supplier's obligation is to deliver the items on or before the date stated in the order/contract. Late deliveries or late completion of the items may be subject to a penalty if this is imposed in the order/contract. No payment is made if the Supplier does not provide the item as stated in order/contract.

Where items are to be delivered the Supplier:

Clearly marks the outside of each consignment or package with the Supplier's name and full details of the destination in accordance with the order and includes a packing note stating the contents thereof; On dispatch of each consignment, sends to PRASA at the address for delivery of the items, an advice note specifying the means of transport, weight, number of volume as appropriate and the point and date of dispatch; Sends to PRASA a detailed priced invoice as soon as is reasonably practical after dispatch of the items, and states on all communications in respect of the order the order number and code number (if any).

Containers / packing material

Unless otherwise stated in the order/contract, no payment is made for containers or packing materials or return to the Supplier.

Title and risk

Without prejudice to rights of rejection under these conditions, title to and risk in the items passes to PRASA when accepted by PRASA.

Rejection

If the Supplier fails to comply with his obligations under the order/contract, PRASA may reject any part of the items by giving written notice to the Supplier specifying the reason for rejection and whether and within what period replacement of items or re-work are required.

In the case of items delivered, PRASA may return the rejected items to the Supplier at the Supplier's risk and expense. Any money paid to the Supplier in respect of the items not replaced within the time required, together with the costs of returning rejected items to the Supplier and obtaining replacement items from a third party, are paid by the Supplier to PRASA.

In the case of service, the Supplier corrects non-conformances as indicated by PRASA.

Warranty

Without prejudice to any other rights of PRASA under these conditions, the Supplier warrants that the items are in accordance with PRASA's requirements, and fit for the purpose for which they are intended, and will remain free from defects for a period of one year (unless another period is stated in the Order) from acceptance of the items by PRASA.

Indemnity

The Supplier indemnifies PRASA against all actions, suits, claims, demands, costs, charges and expenses arising in connection therewith arising from the negligence, infringement of intellectual or legal rights or breach of statutory duty of the Supplier, his subcontractors, agents or servants, or from the Supplier's defective design, materials or workmanship.

The Supplier indemnifies PRASA against claims, proceedings, compensation and costs payable arising out of infringement by the Supplier of the rights of others, except an infringement which arose out of the use by the Supplier of things provided by PRASA.

Assignment and sub-contracting

The successful Bidder awarded the contract may only enter into a subcontracting arrangement with PRASA's prior approval. The contract will be concluded between the successful Bidder and PRASA, therefore, the successful Bidder and not the sub-contractor will be held liable for performance in terms of its contractual obligations.

Governing law

The order/contract is governed by the law of the Republic of South Africa and the parties hereby submit to the non-exclusive jurisdiction of the South African courts.

BIDDER'S DISCLOSURE

1. PURPOSE OF THE FORM

Any person (natural or juristic) may make an offer or offers in terms of this invitation to bid. In line with the principles of transparency, accountability, impartiality, and ethics as enshrined in the Constitution of the Republic of South Africa and further expressed in various pieces of legislation, it is required for the bidder to make this declaration in respect of the details required hereunder.

Where a person/s are listed in the Register for Tender Defaulters and / or the List of Restricted Suppliers, that person will automatically be disqualified from the bid process.

2. Bidder's declaration

2.1 Is the bidder, or any of its directors / trustees / shareholders / members / partners or any person having a controlling interest¹ in the enterprise, employed by the state? **YES/NO**

2.1.1 If so, furnish particulars of the names, individual identity numbers, and, if applicable, state employee numbers of sole proprietor/ directors / trustees / shareholders / members/ partners or any person having a controlling interest in the enterprise, in table below.

Full Name	Identity Number	Name of State institution

2.2 Do you, or any person connected with the bidder, have a relationship with any person who is employed by the procuring institution? **YES/NO**

2.2.1 If so, furnish particulars:
.....
.....

2.3 Does the bidder or any of its directors / trustees / shareholders / members / partners or any person having a controlling interest in the enterprise have any interest in any other related enterprise whether or not they are bidding for this contract? **YES/NO**

2.3.1 If so, furnish particulars:
.....
.....

¹ the power, by one person or a group of persons holding the majority of the equity of an enterprise, alternatively, the person/s having the deciding vote or power to influence or to direct the course and decisions of the enterprise.

4 DECLARATION

I, the undersigned, (name)..... in submitting the accompanying bid, do hereby make the following statements that I certify to be true and complete in every respect:

- 3.1 I have read and I understand the contents of this disclosure;
- 3.2 I understand that the accompanying bid will be disqualified if this disclosure is found not to be true and complete in every respect;
- 3.3 The bidder has arrived at the accompanying bid independently from, and without consultation, communication, agreement or arrangement with any competitor. However, communication between partners in a joint venture or consortium⁵ will not be construed as collusive bidding.
- 3.4 In addition, there have been no consultations, communications, agreements or arrangements with any competitor regarding the quality, quantity, specifications, prices, including methods, factors or formulas used to calculate prices, market allocation, the intention or decision to submit or not to submit the bid, bidding with the intention not to win the bid and conditions or delivery particulars of the products or services to which this bid invitation relates.
- 3.4 The terms of the accompanying bid have not been, and will not be, disclosed by the bidder, directly or indirectly, to any competitor, prior to the date and time of the official bid opening or of the awarding of the contract.
- 3.5 There have been no consultations, communications, agreements or arrangements made by the bidder with any official of the procuring institution in relation to this procurement process prior to and during the bidding process except to provide clarification on the bid submitted where so required by the institution; and the bidder was not involved in the drafting of the specifications or terms of reference for this bid.
- 3.6 I am aware that, in addition and without prejudice to any other remedy provided to combat any restrictive practices related to bids and contracts, bids that are suspicious will be reported to the Competition Commission for investigation and possible imposition of administrative penalties in terms of section 59 of the Competition Act No 89 of 1998 and or may be reported to the National Prosecuting Authority (NPA) for criminal investigation and or may be restricted from conducting business with the public sector for a period not exceeding ten (10) years in terms of the Prevention and Combating of Corrupt Activities Act No 12 of 2004 or any other applicable legislation.

I CERTIFY THAT THE INFORMATION FURNISHED IN PARAGRAPHS 1, 2, 3 and 4 ABOVE IS CORRECT.
I ACCEPT THAT THE STATE MAY REJECT THE BID OR ACT AGAINST ME IN TERMS OF PARAGRAPH 6 OF PFMA SCM INSTRUCTION 03 OF 2021/22 ON PREVENTING AND COMBATING ABUSE IN THE SUPPLY CHAIN MANAGEMENT SYSTEM SHOULD THIS DECLARATION PROVE TO BE FALSE.

.....
Signature	Date
.....
Position	Name of bidder

⁵ Joint venture or Consortium means an association of persons for the purpose of combining their expertise, property, capital, efforts, skill and knowledge in an activity for the execution of a contract.

PREFERENCE POINTS CLAIM FORM IN TERMS OF THE PREFERENTIAL PROCUREMENT REGULATIONS 2022

This preference form must form part of all tenders invited. It contains general information and serves as a claim form for preference points for specific goals.

NB: BEFORE COMPLETING THIS FORM, TENDERERS MUST STUDY THE GENERAL CONDITIONS, DEFINITIONS AND DIRECTIVES APPLICABLE IN RESPECT OF THE TENDER AND PREFERENTIAL PROCUREMENT REGULATIONS, 2022

1. GENERAL CONDITIONS

1.1 The following preference point systems are applicable to invitations to tender:

- the 80/20 system for requirements with a Rand value of up to R50 000 000 (all applicable taxes included); and
- the 90/10 system for requirements with a Rand value above R50 000 000 (all applicable taxes included).

1.2 **To be completed by the organ of state**

The applicable preference point system for this tender is the 80/20 preference point system.

- a) Either the 80/20 preference point system will be applicable in this tender. The lowest/ highest acceptable tender will be used to determine the accurate system once tenders are received.

1.3 Points for this tender (even in the case of a tender for income-generating contracts) shall be awarded for:

- (a) Price; and
(b) Specific Goals.

The maximum points for this tender are allocated as follows:

	POINTS
PRICE	80
SPECIFIC GOALS	20
Total points for Price and Specific Goals	100

1.4 Failure on the part of a tenderer to submit proof or documentation required in terms of this tender to claim points for specific goals with the tender, will be interpreted to mean that preference points for specific goals are not claimed.

1.5 The organ of state reserves the right to require of a tenderer, either before a tender is adjudicated or at any time subsequently, to substantiate any claim in regard to preferences, in any manner required by the organ of state.

2. DEFINITIONS

- (a) **“tender”** means a written offer in the form determined by an organ of state in response to an invitation to provide goods or services through price quotations, competitive tendering process or any other method envisaged in legislation;
- (b) **“price”** means an amount of money tendered for goods or services, and includes all applicable taxes less all unconditional discounts;
- (c) **“rand value”** means the total estimated value of a contract in Rand, calculated at the time of bid invitation, and includes all applicable taxes;
- (d) **“tender for income-generating contracts”** means a written offer in the form determined by an organ of state in response to an invitation for the origination of income-generating contracts through any method envisaged in legislation that will result in a legal agreement between the organ of state and a third party that produces revenue for the organ of state, and includes, but is not limited to, leasing and disposal of assets and concession contracts, excluding direct sales and disposal of assets through public auctions; and
- (e) **“the Act”** means the Preferential Procurement Policy Framework Act, 2000 (Act No. 5 of 2000).

3. FORMULAE FOR PROCUREMENT OF GOODS AND SERVICES

3.2. POINTS AWARDED FOR PRICE

3.1.1 THE 80/20 PREFERENCE POINT SYSTEMS

A maximum of 80 points is allocated for price on the following basis:

80/20

$$Ps = 80 \left(1 - \frac{Pt - P_{min}}{P_{min}} \right)$$

Where

- Ps = Points scored for price of tender under consideration
Pt = Price of tender under consideration
Pmin = Price of lowest acceptable tender

3.3. FORMULAE FOR DISPOSAL OR LEASING OF STATE ASSETS AND INCOME GENERATING PROCUREMENT

3.3.1. POINTS AWARDED FOR PRICE

A maximum of 80 points is allocated for price on the following basis:

80/20

$$Ps = 80 \left(1 + \frac{Pt - P_{max}}{P_{max}} \right)$$

Where

- Ps = Points scored for price of tender under consideration
Pt = Price of tender under consideration
Pmax = Price of highest acceptable tender

4. POINTS AWARDED FOR SPECIFIC GOALS

- 4.1. In terms of Regulation 4(2); 5(2); 6(2) and 7(2) of the Preferential Procurement Regulations, preference points must be awarded for specific goals stated in the tender. For the purposes of this tender the tenderer will be allocated points based on the goals stated in table 1 below as may be supported by proof/ documentation stated in the conditions of this tender:
- 4.2. In cases where organs of state intend to use Regulation 3(2) of the Regulations, which states that, if it is unclear whether the 80/20 or 90/10 preference point system applies, an organ of state must, in the tender documents, stipulate in the case of—
- (a) an invitation for tender for income-generating contracts, that either the 80/20 or 90/10 preference point system will apply and that the highest acceptable tender will be used to determine the applicable preference point system; or
 - (b) any other invitation for tender, that either the 80/20 or 90/10 preference point system will apply and that the lowest acceptable tender will be used to determine the applicable preference point system,
- then the organ of state must indicate the points allocated for specific goals for both the 90/10 and 80/20 preference point system.

Table 1: Specific goals for the tender and points claimed are indicated per the table below.

(Note to organs of state: Where either the 90/10 or 80/20 preference point system is applicable, corresponding points must also be indicated as such.)

Note to tenderers: The tenderer must indicate how they claim points for each preference point system.)

The specific goals allocated points in terms of this tender	Number of points allocated (80/20 system) (To be completed by the organ of state)	Number of points claimed (80/20 system) (To be completed by the tenderer)
Entities with a B-BBEE contributor status of at least level 2 - B-BBEE Certificate/Affidavit	10	
51% Black Owned - CIPC Documents/B-BBEE Certificate/Affidavit	10	
Total	20	

DECLARATION WITH REGARD TO COMPANY/FIRM

4.3. Name of company/firm.....

4.4. Company registration number:

4.5. TYPE OF COMPANY/ FIRM

- Partnership/Joint Venture / Consortium
- One-person business/sole propriety
- Close corporation
- Public Company
- Personal Liability Company
- (Pty) Limited
- Non-Profit Company
- State Owned Company

[TICK APPLICABLE BOX]

4.6. I, the undersigned, who is duly authorised to do so on behalf of the company/firm, certify that the points claimed, based on the specific goals as advised in the tender, qualifies the company/ firm for the preference(s) shown and I acknowledge that:

- i) The information furnished is true and correct;
- ii) The preference points claimed are in accordance with the General Conditions as indicated in paragraph 1 of this form;
- iii) In the event of a contract being awarded as a result of points claimed as shown in paragraphs 1.4 and 4.2, the contractor may be required to furnish documentary proof to the satisfaction of the organ of state that the claims are correct;
- iv) If the specific goals have been claimed or obtained on a fraudulent basis or any of the conditions of contract have not been fulfilled, the organ of state may, in addition to any other remedy it may have –
 - (a) disqualify the person from the tendering process;
 - (b) recover costs, losses or damages it has incurred or suffered as a result of that person’s conduct;
 - (c) cancel the contract and claim any damages which it has suffered as a result of having to make less favourable arrangements due to such cancellation;
 - (d) recommend that the tenderer or contractor, its shareholders and directors, or only the shareholders and directors who acted on a fraudulent basis, be restricted from obtaining business from any organ of state for a period not exceeding 10 years, after the *audi alteram partem* (hear the other side) rule has been applied; and
 - (e) forward the matter for criminal prosecution, if deemed necessary.

.....
SIGNATURE(S) OF TENDERER(S)

SURNAME AND NAME:

DATE:

ADDRESS:

.....

.....

.....

SECTION 8
SPECIFICATION/SCOPE OF WORK

**SUPPLY AND DELIVERY OF CROSS-SECTION AREA OF 161mm² LENGTH OF 1830m
HARD DRAWN GROOVED, COPPER- MAGNESIUM CONTACT WIRE FOR ELECTRICAL
DEPARTMENT IN KZN REGION**

1. PROJECT PURPOSE

The purpose of this project supply and deliver of cross-sectional area of 161mm² length 1830 hard drawn grooved, contact copper- magnesium wire as per spec BBD7267 Version 2 (including transportation) for KZN region as indicated on the bill of quantities.

2. GENERAL

- 2.1. The contractor shall be responsible for the supply and deliver of cross-sectional area of 161mm² length 1830 hard drawn grooved, copper-magnesium contact wire as per spec BBD7267 Version 2 (including transportation)
- 2.2. Metrorail reserves the right to inspect and or test any material or equipment during the deliver process.
- 2.3. Material shall be visually inspected for damages or defects during delivery.
- 2.4. The material shall be subjected to a guarantee period of one year. The guarantee period shall commence the day it is formally handed over to and accepted by Metrorail.
- 2.5. The contractor shall undertake work on the replace any defects that may arise during the guarantee period within 7 days of him being notified by Metrorail of such defects.

3. ADDITIONAL WORKS

Any additional material delivered not authorized by the regional electrical engineer, even if proven necessary will be tenderer's own account.

4. DESCRIPTION OF WORK

The contractor shall perform the following task:

- 4.1 Supply and deliver of cross-sectional area of 161mm² length 1830m hard drawn grooved, copper-magnesium contact wire as per spec BBD7267 Version 2 (including transportation)

5. Duration

The duration of the contract shall not exceed **FOUR (4)** months. Delivery shall commence immediately from date of award.

6. PENALTIES

- 6.1. The contractor shall be charged a penalty of R500 for each delayed in fails to deliver material in time
- 6.2. The contractor shall be charged a penalty of R1000 for each incorrect or defective item delivered to PRASA.

7. DELIVERY ADDRESS:

Durban Electrical Depot, 65 Masabalala Yengwa Avenue, Durban Station

8. MANDATORY DOCUMENTS

The supplier must submit in writing (on a signed company letterhead) with this RFQ, acknowledging that:

- The technical specifications of the products listed in the RFQ document will be met.
- Non-conformances will be closed within 10 days

BILL OF QUANTITY

ITEM NO	DESCRIPTION	UNIT	QTY	RATE		AMOUNT	
				R	C	R	C
15.1	DURBAN YARD FLY OVER						
15.1.1	Supply & delivery cross sectional area of 161mm ² length of 1830m hard drawn grooved, copper-magnesium contact wire as per spec BBD7267 Version 2 (including transportation) Cross Sectional Area: 161mm ² , length 1830m in continuous length	Drum	2				
				SUB TOTAL			
				VAT 15%			
				GRAND TOTAL			

TECHNOLOGY MANAGEMENT

SPECIFICATION

SPECIFICATION FOR GROOVED, COPPER-MAGNESIUM CONTACT WIRE, FOR ELECTRICAL TRACTION PURPOSES.

Author:	Technician in Training Section: Technology Management	N.C Mokhomo	
Approved	Senior Engineer Section: Technology Management	L.O. Borchard	
Authorised	Principal Engineer Section: Technology Management	S.E Sguda	
		Date	March 2016

Circulation Restricted To

Transnet Freight Rail
Transnet and Relevant Third Parties
Unrestricted

© This document as a whole is protected by copyright. The information herein is the sole property of Transnet Ltd. It may not be used, disclosed or reproduced in part or in whole in any manner whatsoever, except with the written permission of and in a manner permitted by the proprietors.

INDEX

SECTION	CONTENTS	PAGE
1.0	SCOPE	3
2.0	REFERENCES	3
3.0	APPENDICES	3
4.0	METHOD OF TENDERING	3
5.0	MATERIAL	3
6.0	MARKING	4
7.0	SIZE AND LENGTH	4
8.0	DRUMS AND WINDING	4
9.0	MARKING OF DRUMS	4
10.0	INFORMATION	5
11.0	TESTS	5
12.0	APPENDIX 1	6
13.0	APPENDIX 2	7
14.0	APPENDIX 3	8
15.0	APPENDIX 4	9

1.0 SCOPE

This specification covers Transnet's requirements for the manufacture, testing and supply of grooved, 107 mm² or 161 mm² copper-magnesium (CuMg0,2) contact wire.

2.0 REFERENCES

2.1 The following specification and drawing are referred to herein:

2.1.1 British Standards Specification:

BS EN 50149 : Railway application – Fixed installation – Electrical traction – Copper and copper alloy grooved contact wires

2.1.2 Transnet Drawing:

BBD 7973 : Wooden cable drum for 107 & 161 mm² contact wire.

3.0 APPENDICES

The following appendices form an integral part of this specification:

3.1 Appendix 1: Cross-sectional profile of the 107 mm² or 161 mm² contact wire.

3.2 Appendix 2: Special Marking for Identification Purposes.

(A) Specifies the nature of the imprinting

(B) Identification grooves, text size and position.

3.3 Appendix 3: Test Results of 107 mm² Grooved Contact Wire.

This appendix specifies the form in which the test results for 107 mm² grooved copper will be presented in order to check compliance.

3.4 Appendix 4: Test Results of 161 mm² Grooved Contact Wire.

This appendix specifies the form in which the test results for 161 mm² grooved Copper will be presented in order to check compliance.

4.0 METHOD OF TENDERING

4.1 Tenderers shall indicate clause by clause compliance or non-compliance with this specification. This shall take the form of a separate document listing all the specification clause numbers indicating the individual statement of compliance or non-compliance.

4.2 A statement of non-compliance shall be motivated by the tenderer.

4.2.1 The test results (Appendix 3 and 4) to this specification shall be fully completed by the tenderers.

4.2.2 Failure to comply with clauses 4.1, 4.2 and 4.3 may preclude a tender from further Consideration.

5.0 MATERIAL

5.1 The wire shall be made from high conductivity copper-magnesium CuMg0,2, in accordance with specification BS EN 50149. The configuration and cross-sectional areas are depicted in Appendix 1.

5.2 The wire shall comply with all the properties detailed in Appendix 3 and 4 hereof for 107 mm² or 161 mm² respectively.

6.0 MARKING

- 6.1 The wire shall have imprinted on the upper lobe of the wire the words TRANSNET as indicated in Appendix 2(A).
- 6.2 Copper-magnesium wire shall incorporate three identification grooves on the upper lobe of the wire in accordance with Appendix 2(B). These grooves will identify the copper-alloy in accordance with specification BS EN 50149.

7.0 SIZE AND LENGTH

- 7.1 The wire shall have a cross sectional area of 107 mm² or 161 mm² and shall have dimensions in accordance with Appendix 1.
- 7.2 The 107 mm² wire shall be supplied in continuous lengths of 1620 meter [(plus 2 m minus 0 (zero))] and the 161 mm² wire shall be supplied in continuous lengths of 1830 meter [(plus 2 m minus 0 (zero))].

8.0 DRUMS AND WINDING

- 8.1 Each drum shall be manufactured in accordance with Transnet's drawing No. BBD 7973 and shall have the wire tightly and evenly wound thereon.
- 8.2 The inner end of each length shall be marked at a distance of 30m from that end in such a manner as to give an observer, 6 m away from the drum, an indication of the approaching end of the length when the wire is being reeled off at the rate of 60 m per minute.
- 8.3 The wire shall be wound on the drum with the vertical axis of the wire at right angles to the axis of the drum and in such a manner that the contact surface of the wire shall be to the bottom when the wire is unreeled of the top of the drum. The wire shall be wound in uniform layers with turns tightly together and free from kinks and crossovers.
- 8.4 Both ends of the wire must be securely fixed to the drum flange.

9.0 MARKING OF DRUMS

- 9.1 Each drum shall have, clearly marked on the outer surface of one flange, the following information:
- The manufacturer's name
 - The size of the wire
 - The total length of the wire contained thereon
 - The gross mass
 - The net mass
 - Transnet's stores order number
 - A suitable sequence number for identification purposes
- 9.2 Arrows indicating the direction of un-winding, must appear clearly marked on both flanges of the drum.

10.0 INFORMATION

Tenderers shall submit with their tenders the following information:

- Maximum resistance of the wire to be supplied, (Ω/km at 20 °C)
- Minimum tensile strength of the wire to be supplied (kN)
- Actual number and full details of the type of joints in each length of wire to be supplied

11.0 TESTS

- 11.1 A sample length of wire from the end of each drum shall be cut off for test purposes. When relevant, one sample length in five shall include a joint. All samples shall be tested to ensure compliance with clauses 5.2 and 7.1 hereof. Whenever samples cut off in terms of the above, includes a joint, the exact location of this joint shall be clearly and positively marked by means of non destructive chemical etching. This is required to ensure that the wire at the joints can be tested for compliance with the requirements of clause 5.2.
- 11.1.1 After removal of a sample length of wire from a drum, the actual length of wire remaining thereon shall not be less than that called for in clause 7.2.
- 11.2 Since creep of the contact wire has to be taken into account during erection stages and afterwards during normal maintenance, tenderers must give figures indicating the initial and final creep rate that can be expected. The tensile stress for these creep rates should also be indicated.
- 11.3 Tests to confirm the compliance of the wire with the technical properties laid down in clause 5.2, shall be carried out on the sample lengths by the manufacturer as detailed in specification BS EN 50149.
- 11.4 Transnet reserves the right to witness all tests.
- 11.5 Copies of test certificates giving details of all tests results are to be handed, immediately after the tests, to Transnet, to confirm that the wire and drums meet the electrical and mechanical properties required by this specification.
- 11.5.1 The test certificates to be supplied to Transnet shall be as shown in Appendix 3 and 4.

CROSS-SECTIONAL PROFILES

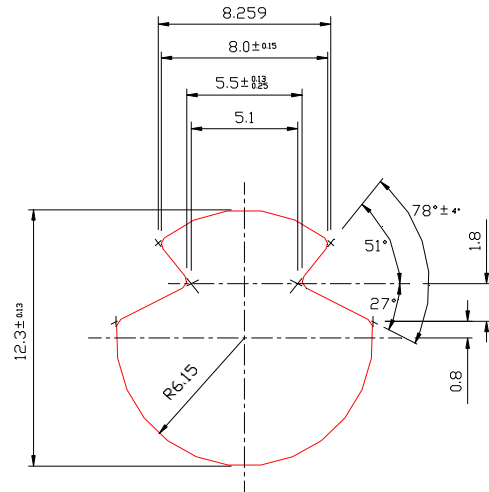

Figure 1: Cross-sectional profile of a 107 mm² Contact wire.

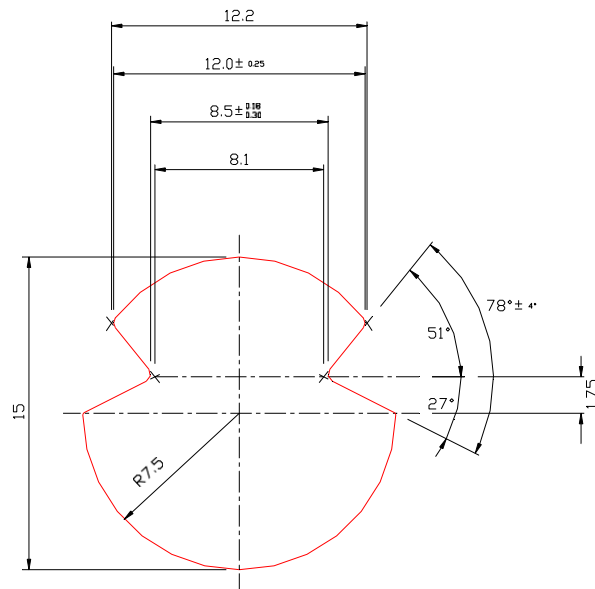
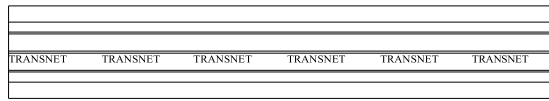

Figure 2: Cross-sectional profile of a 161 mm² Contact wire.

SPECIAL MARKING FOR IDENTIFICATION PURPOSES

(A)



107mm² Contact wire

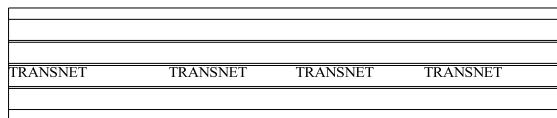

161mm² Contact wire

In both cases (107 mm² and 161 mm² contact wire) the height of the text must be as indicated below.

(B)



107 mm²

161 mm²

(Illustration not to scale)

Identification grooves, Text size and position.

TEST RESULTS OF 107mm² GROOVED CONTACT WIRE

Customer's Name: _____

Customers Order No.: _____

Drum No.	Nominal Mass per km (kg)	Area (mm ²)	Resistance per km @ 20°C	Tensile strength N/mm ²	Elongation on 200 mm (%)	Twists in 250 mm	Reverse Bends	Notes
	951±3%	107	0.216 max	440 min	3.0 min	5 min	6 min	

Signed: Quality Inspector: _____ Date: _____

Testing Authority: _____ Date: _____

TEST RESULTS OF 161mm² GROOVED CONTACT WIRE

Customer's Name: _____

Customers Order No.: _____

Drum No.	Nominal Mass per km (kg)	Area (mm ²)	Resistance per km @ 20°C	Tensile strength N/mm ²	Elongation on 200 mm (%)	Twists in 250 mm	Reverse Bends	Notes
	1432 ±3%	161	0.138 max	420 min	3.0 min	5 min	6 min	

Signed: Quality Inspector: _____ Date: _____

Testing Authority: _____ Date: _____