

FILL WIDENING FOR SIDEWALK

SCALE 1:50

- 1 IMPERMEABLE BACKFILL MATERIAL
- 2 NATURAL PERMEABLE MATERIAL - COARSE SAND (5mm NMP5)
- 3 110mm PERFORATED GEO-PIPE
- 4 CRUSHED STONES - COARSE MATERIAL (20mm NMP5)
- 5 U24 BIDIM GEOTEXTILE OR SIMILAR APPROVED

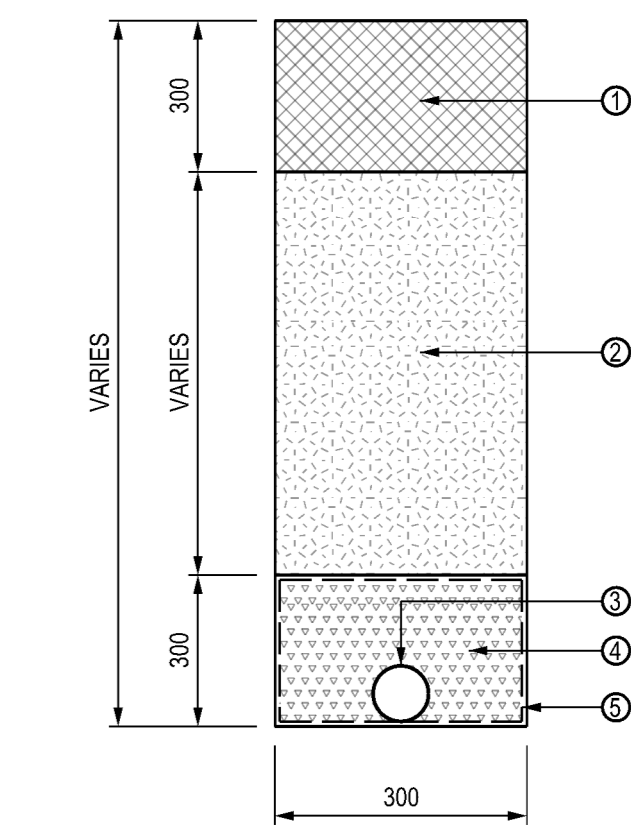

TYPICAL SECTION THROUGH SUBSOIL DRAIN
SCALE 1:15

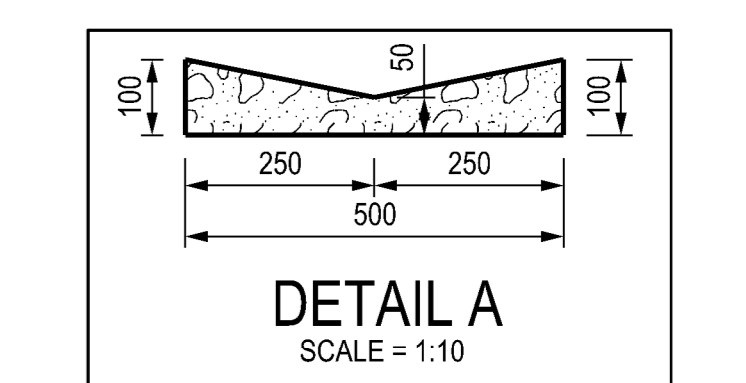

DETAIL A
SCALE = 1:10

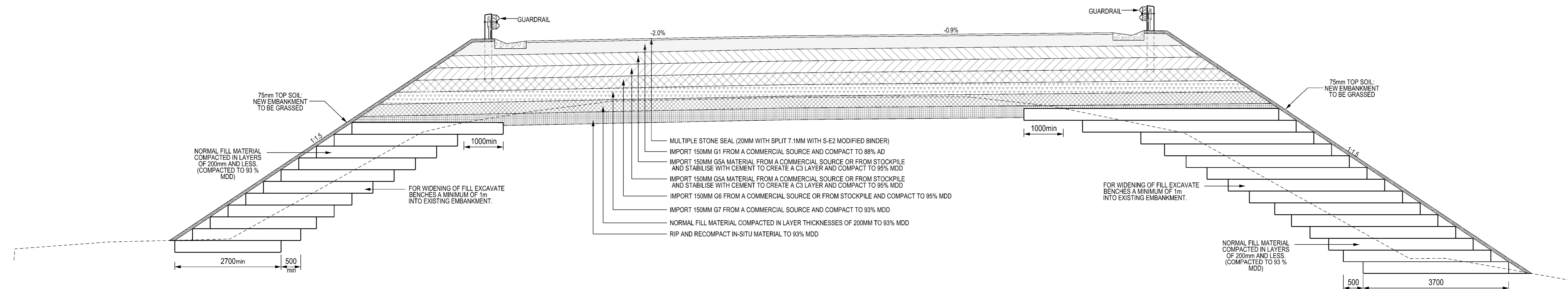

FILL WIDENING FOR ROAD

SCALE 1:50

No.	DATE	DESCRIPTION	BY
V1	DATE	REVISION	J.J. OLIVIER CONSULT. ENG.

CONSTRUCTION RECORD (AS-BUILT)
WORKS CONTRACT ENGINEER
Name :
Prof. Reg. No. :
Date :
SANRAL PROJECT MANAGER
Name :
Date :

ilifa
AFRICA ENGINEERS
35A Piet Retief Street
PO Box 802
Harrismith 9880
Tel: (058) 622 1297
Fax: 058 623 0827
E-mail: harrismith@ilifa.biz

QUANTRA
CONSULTING SA Reg No: 2015/24071/07
103 Maranata Ave
Mossel Bay 6500
South Africa
+27 44 690 4417
Mosselbaai@Quantra.co.za

DESIGNED BY
NAME : A.W. POORTMAN
Prof. Reg. No. :
CHECKED BY
NAME : P.J.R. van WYK
Prof. Reg. No. :
DRAWN BY
NAME : N.L. MOKGENA

CONSULTANT APPROVAL
Name : J.J. OLIVIER
Prof. Reg. No. : 940253
Date : FEBRUARY 2022

HEAD OFFICE
48 Tambotie Avenue
Val de Grace
Pretoria
0184
PO Box 415
Pretoria 0001
South Africa
Tel: (012) 844 8000

SANRAL
BUILDING SOUTH AFRICA THROUGH BETTER ROADS

NORTHERN REGION
38 Ida Street
Menlo Park
Pretoria
0081
Private Bag X17
Lynwood Ridge
0040
Tel: (012) 426 6200

ACCEPTANCE
THIS ACCEPTANCE IS FOR PROCEDURAL AND ADMINISTRATIVE REVIEW PURPOSES ONLY AND DOES NOT ATTRACT LEGAL LIABILITY OR LIABILITY OF ANY KIND FROM WHATSOEVER CAUSE OR HOWSOEVER ARISING
for the SA NATIONAL ROADS AGENCY SOC LTD.
Date:

PROJECT DESCRIPTION
DILPS: IMPROVEMENT ON NATIONAL ROUTE R52 SECTION 3 FROM KOSTER (KM 0.000) TO N4 RUSTENBURG (KM 38.700)
DRAWING DESCRIPTION
BENCHING DETAILS
SCALE : AS SHOWN

PROJECT NUMBER	R.052-030-2020/1	
DRAWING LOCATION DATA	START	END
ROUTE	R 052	R 052
SECTION	03N	03N
DRAWING km DISTANCE	0.000	36.691
DRAWING TYPE	ROADS - CROSS-SECTIONS	
BRIDGE/STRUCTURE No.		
CONSULTANT DRAWING No.	H17- 028-00-RR-D59	VER V1
SANRAL DOCUMENT #		

PLAN No: H17- 028-00- RR-D059